

**WORK PLAN  
FOR  
CONSTRUCTION OF NEW WELLS  
AT HADNOT POINT INDUSTRIAL AREA  
NORTH AND SOUTH GROUNDWATER TREATMENT PLANTS  
MCB CAMP LEJEUNE, NORTH CAROLINA**

Prepared for:

DEPARTMENT OF THE NAVY  
Contract No. N62470-93-D-3032  
Atlantic Division  
Naval Facilities Engineering Command  
6500 Hampton Boulevard  
Building A (South East Wing) 3rd Floor  
Norfolk, VA 23508

Prepared by:

OHM Remediation Services Corp.  
5445 Triangle Parkway, Suite 400  
Norcross, GA 30092

Reviewed by:

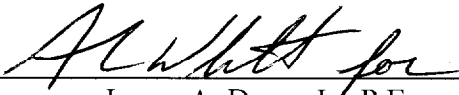
  
James A. Dunn, Jr., P.E.  
Senior Project Manager

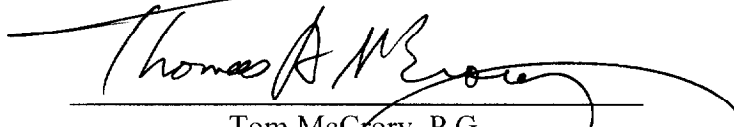
  
Tom McCrory, P.G.  
Senior Project Hydrogeologist

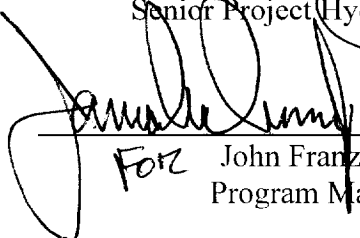
  
John Franz, P.E.  
Program Manager

September 1998  
Delivery Order 0175  
Project No. 20500

## **TABLE OF CONTENTS**

---

<b>1.0 INTRODUCTION.....</b>	<b>1-1</b>
1.1 SITE BACKGROUND.....	1-1
1.2 SITE DESCRIPTION.....	1-1
1.3 SITE HISTORY.....	1-2
<b>2.0 OBJECTIVE .....</b>	<b>2-1</b>
<b>3.0 SITE PREPARATION AND MOBILIZATION .....</b>	<b>3-1</b>
3.1 SITE PREPARATION.....	3-1
3.2 UTILITY CLEARANCES.....	3-2
<b>4.0 SCOPE OF WORK .....</b>	<b>4-1</b>
4.1 WELLS AND WELL VAULTS INSTALLATION.....	4-1
4.2 WELL ABANDONMENT .....	4-1
4.3 T&D OF DRILLING WASTE .....	4-2
4.4 WELL DEVELOPMENT AND STARTUP .....	4-2
4.5 PIPING AND WELL HEAD INSTALLATION.....	4-2
4.6 PUMPS, CONTROLLERS, AND PIPING .....	4-3
4.7 AIR COMPRESSOR .....	4-3
<b>5.0 OPERATION AND MAINTENENCE FOR WATER TREATMENT     PLANTS.....</b>	<b>5-1</b>
<b>6.0 REPORTING .....</b>	<b>6-1</b>
6.1 WELL LOGS AND PERMITS .....	6-1
6.2 ENVIRONMENTAL CONDITIONS REPORT .....	6-1
6.3 DAILY REPORTING.....	6-1
6.3 AS-BUILT DRAWINGS.....	6-1
6.4 MONTHLY STATUS REPORT .....	6-1
6.5 CONTRACTOR CLOSEOUT REPORT .....	6-1
<b>7.0 PROJECT SCHEDULE.....</b>	<b>7-1</b>

### **DRAWINGS**

Figure 1	Vicinity Map
Figure 2	New Piping Plan – South Plant
Figure 3	New Piping Plan – North Plant
Figure 4	Extraction Well Detail
Figure 5	Air Supply Schematic

### **APPENDICES**

Appendix A	Health and Safety Plan
Appendix B	Sampling and Analysis Plan
Appendix C	Environmental Protection Plan
Appendix D	T&D Plan
Appendix E	QC Plan

## **1.0 INTRODUCTION**

---

### **1.1 SITE BACKGROUND**

MCB Camp Lejeune was placed on the Comprehensive Environmental Response, Compensation, and Liability Act (CERCLA), National Priorities List (NPL) effective October 4, 1989 (54 Federal Register 41015, October 4, 1989). Subsequent to this listing, the United States Environmental Protection Agency (USEPA) Region IV, the North Carolina Department of Environment, Health and Natural Resources (NCDEHNR) and the United States Department of the Navy (DoN) entered into a Federal Facilities Agreement (FFA) for MCB Camp Lejeune. The primary purpose of the FFA was to ensure the environmental impacts associated with past and present activities at MCB Camp Lejeune were thoroughly investigated and appropriate CERCLA response / Resources Conservation and Recovery Act (RCRA) corrective action alternatives were developed and implemented as necessary to protect the public health and the environment. Figure 1 presents the vicinity map.

### **1.2 SITE DESCRIPTION**

The information presented in this section was obtained from the scope of work contained in the request for proposal from LANTDIV.

The remediation system at Operable Unit No.1, Site 78, consists of two pump and treat plants, each connected to several recovery wells, located in the Hadnot Point Industrial Area (HPIA) of MCB Camp Lejeune. These plants are generally referred to as the North and South Plants. Both plants were designed based on results of a remedial investigation of the site. An Interim ROD specified the construction of both plants to contain and remediate contaminant plumes in the shallow aquifer at the site. The Final Interim ROD was signed in September 1992. Following completion of the full remedial investigation at the site, the Final ROD was signed in September 1994. The Final ROD specified selected remedies to address areas of contaminated soil in Operable Unit No. 1 as well as the expansion of the treatment system specified by the Interim ROD to include additional extraction wells for the two plants. These plants have been in operation since 1994.

Recent investigative work conducted in the Hadnot Point area by Baker Environmental has identified regions of the groundwater plume that are not being impacted by the current recovery well network. At the North plant, two existing recovery wells (RW-10 and RW-11) will be re-drilled and one new recovery well (RW-12) will be installed. At the South Plant, three new recovery wells (RW-13, RW-14, and RW-15) will be installed.

North and South Plant Water Treatment Systems will continue operation in a manner similar to the last two years. System operation, optimization, maintenance, and repair will be conducted safely and efficiently. Sampling and analysis of influent, effluent, and treatment stages during troubleshooting activities will follow the existing procedures. Recommendations for improving operations by improving on-stream times, reducing

operating costs, and lowering maintenance costs will be presented as opportunities for changes arise.

### **1.3 SITE HISTORY**

Camp Lejeune is a training base for the U.S. Marine Corps, located in Onslow County, North Carolina. The Base covers approximately 170 square miles and includes 14 miles of coast line. MCB Camp Lejeune is bounded to the southeast by the Atlantic Ocean, to the northeast by State Route 24, and to the west by U.S. Route 17. The town of Jacksonville, North Carolina is located north of the Base.

Site 78, constructed in the late 1930s, was the first developed area at MCB Camp Lejeune. It was comprised of approximately 75 buildings and facilities including maintenance shops, gas stations, administrative offices, commissaries, snack bars, warehouses, and storage yards. There is presently no known uncontrolled disposal of wastes related to the various industrial activities at the site. Due to the industrial nature of the site, many spills and leaks have occurred over the years. Most of these spills and leaks have consisted of petroleum-related products and solvents from underground storage tanks (USTs), drums and uncontained waste storage areas. The plants were designed by Baker Environmental and built by O'Brien & Gere in 1995. OHM assumed operation and maintenance (O&M) of the plants in June 1996. Prior to OHM's assumption of operation and maintenance, PDG Environmental Services, Inc. was contracted for O&M of the plants for the period of July 5, 1995 through June 28, 1996. Prior to PDG's assumption of O&M, the plants were subject to a shakedown period performed by the constructor O'Brien & Gere, from June 1, 1995 to July 4, 1995.

Both plants had a history of prior operational problems that related primary to high calcium levels in the water. OHM fixed the equipment, installed a sequestering system, and performed routine maintenance to significantly reduce the calcium problems.



## **2.0 OBJECTIVE**

---

The objective of this project is to:

- **Install one extraction well at the North Plant and 3 wells at the South Plant**
- **Re-drill two wells at the North Plant**
- **Expand the OU1 recovery well networks for both the North and Plants**
- **Develop the extraction wells**
- **Startup wells and maintain operation of both the North and South Water Treatment Plants**

### **3.0 SITE PREPARATION AND MOBILIZATION**

---

#### **3.1 SITE PREPARATION**

Project site cleanup and preparation will consist of the following main activities:

##### ***Temporary Facilities Installation***

OHM will utilize its office already located at Lot 203 Camp Lejeune as an administrative area and command center. In addition, the North and South Water Treatment Buildings will be used as on-site locations.

##### ***Site Survey***

OHM will layout extraction well locations, the jack and bore locations, trenching, and equipment lay down areas prior to installation. The locations will be visibly marked using reinforcing bars and/or wood stakes. Utilities will be identified before any below grade work is started. Any unidentified lines found during trenching will be included in the as built drawings.

Following system installation, a North Carolina licensed professional surveyor will be subcontracted to survey locations of the new recovery wells and trench lines wells, and equipment compound to assist in preparation of as-built drawings.

##### ***Erosion and Sedimentation Control***

OHM will establish controls to prevent erosion and sedimentation through the use of sediment fencing and diversion berms. In this manner, OHM will mitigate the spread of contamination to other areas and minimize run-on into the active work area. Silt fencing will be placed along the down gradient sides of trenched areas. The Environmental Protection Plan included in Appendix C of this RAWP provides details on environmental controls.

##### ***Install Construction Fences***

OHM personnel will erect safety fencing around the designated work areas. Fencing will be 3 feet high, bright orange, polyethylene, and mesh fence to prevent personnel from accidentally entering an open trench.

##### ***Site Security***

All persons entering the site will be required to sign in and out daily. OHM reserves the right to deny access to any individual not showing proper identification.

##### ***Health and Safety Zones***

The site will be segregated into work areas on the basis of degree of hazards and PPE requirements. Personnel working within the Contamination Reduction Zone (CRZ) will be required to wear the appropriate PPE as outlined in the Site-Specific Health and Safety Plan in Appendix A. Excavation areas within the CRZ will be designated the exclusion zone and will be delineated by orange safety fencing.

### ***Personnel Decontamination Facility***

OHM will set up a personnel decontamination area at the site in the vicinity of the construction areas. It will be furnished with portable wash basins. All decontamination and cleaning water generated from the decontamination activities will be collected and stored prior to analysis and subsequent disposal.

## **3.2 UTILITY CLEARANCES**

Figure 2 and Figure 3 show the approximate location of utilities in the area. Base personnel will identify and mark all known utilities potentially within the work zones. OHM will subcontract a utility finder for marking utility lines. OHM will exercise caution while performing ground intrusive work and will implement its Standard Operation Procedures for excavation near utilities. Techniques for minimizing damage to existing utilities include the use of location devices, utility location services, and hand digging. OHM's Health and Safety Plan also addresses these concerns.

## **4.0 SCOPE OF WORK**

---

### **4.1 WELLS AND WELL VAULTS INSTALLATION**

OHM's hydrogeologist will prepare location and boring log data regarding installation of new recovery wells at Hadnot Point North and South Plants. The on-site hydrogeologist will determine exact location of the new wells based on utility locations and surface conditions. If subsurface obstructions are encountered during drilling activities, then the drilling location will be off-set to the closest possible adjacent location. One new extraction well will be installed at the North Plant (RW-12) and two existing extraction wells (RW-10 and RW-11) will be redrilled as shown in Figure 3. Three new extraction wells will be installed at the South Plant (RW-13, RW-14, RW-15) as shown in Figure 2. The extraction wells will be identical to the previous wells except 10-slot screen will be used instead of 20-slot screen to help minimize silt in the water recovery system.

A well installation subcontractor will mobilize a drill rig to the site to advance borings and to install and drill the five recovery wells. The wells will be installed using a hollow stem auger or equivalent to drill a 12-inch diameter bore to a depth of 35'-10" as shown in Figure 4. The well casing will be 6-inch 304 stainless steel with 25' of 10-slot wire wrap screen having threaded flush joints. A 6-inch long threaded stainless steel adapter with equal ply will be installed at the bottom of the well screen. A filter pack consisting of a clean quartz sand will be installed from the bottom of the boring to at least 2' above the top of the screened interval pack will be used and a 5'-6" benonite seal will be used to around the well casing. An OHM hydrogeologist will be on-site during the well installation period to provide oversight. OHM personnel and drilling crews will be OSHA and Safety trained in accordance with CFR 1910.120.

The concrete well vaults will approximately 4"- 6" deep and will be similar to the existing vaults. Well vaults will be slightly raised above existing grade to limit intrusion of surface water. They will be installed using a Backhoe. A grout seal will be placed around the well. Excess soil from the vaults will be used as trenching fill. The vault will be equipped with a ladder for easier access. The vaults are classified as a confined space entry and Health and Safety procedures will be properly followed.

All piping, valves and pressure gauges inside the well vaults will be prefabricated to the greatest extent possible. Well vault piping, connectors, valves, and check valves will be bronze. Piping in the well vaults will be supported to reduce pipe stress. A readily accessible sampling port will be provided.

### **4.2 WELL ABANDONMENT**

If wells RW-10 and RW-11 cannot be re-drilled, they will be abandoned. The on-site hydrogeologist will provide documentation for well abandonment.

### **4.3 T&D OF DRILLING WASTE**

Drilling waste will be stored in a roll off box. Analytical Method –TCLP (1311) will be used to characterize the waste for disposal purposes. OHM’s T&D Coordinator will document the disposal of the drilling waste. Appendix A contains the Health and Safety Plan.

Based on the materials identified that will require off-site disposal, it is anticipated that the materials will not be RCRA hazardous pursuant to 40 CFR 261.

### **4.4 WELL DEVELOPMENT AND STARTUP**

The OHM hydrogeologist will develop each new well for approximately one day. Water from each well will be sent to the vac truck. The water from the vac truck will be treated at the North or South Water Treatment Plants.

During this activity, existing wells may be cleaned. The hydrogeologist will evaluate to determine if a 10 slot well screen sleeve should be installed, to help minimize silt from being transferred from the well to the water treatment plant.

Prior to startup of the new wells, baseline data for the new extraction wells will be collected. The Sampling and Analysis Plan is presented in Appendix B.

Startup of the new wells will be supervised by the water treatment operator and the hydrogeologist. Sampling and analysis of influent, effluent, and treatment stages during troubleshooting activities will be conducted as needed.

### **4.5 PIPING AND WELL HEAD INSTALLATION**

The North and South Water Treatment Plants are located in an active industrial part of the base. OHM’s Site Superintendent will coordinate daily construction tasks with the base to re-route traffic flow and schedule intrusive work during certain times to minimize disruption of traffic affected by OHM operations.

OHM’s field personnel will excavate the trenches, install the trench piping, install the extraction well vaults, and complete well head piping. Air and extraction water header piping will be installed to the depths indicated on the plans. Conventional trenching methods will be employed. Hand excavation will be required in areas immediately adjacent to existing utilities. Trenching width will be kept to a minimum to reduce excess soil generation. Air lines will utilize Air-Pro HDPE with socket welded joints. Underground extraction water header piping will be HDPE SDR 11 butt welded piping. The Air-Pro piping will be pressure tested for leaks in accordance with manufacture’s recommendations. The excavated material shall be used as backfill and placed in 6-inch lifts. A plate compactor will be utilized for compacting soil below traffic bearing asphalt or paved surfaces. See Figure 4 for trenching details.

The previous piping system utilized air hose inserted within a 6-inch diameter PVC casing pipe. For a long-term application, air hose has a tendency to leak at joints. Air-Pro piping is recommended as a substitute for this application. New casing pipe is not required.

#### **4.6 PUMPS, CONTROLLERS, AND PIPING**

The pumps and controllers will match the existing wells (Ejector Systems Incorporated Project No. 932451). Used pumps and controllers currently exist at the site, but are in need of repair. All stored pumps and controllers will be returned to Ejector Systems Incorporated for re-manufacturing. Repaired equipment will be used as possible. No spare pumps or controllers will be kept at the job site. The pumps and controllers are off-the-self items from Ejector Systems Incorporated.

The pneumatic pumps are Total Fluids top and bottom fill, Model WETB 3 diameter by 4 feet long. The pump will be constructed of 304 stainless steel, 304 stainless steel check valves, Viton seals and stainless steel fittings. A winch with 6 inch support and cable will be installed in the well for removing the pump from the well.

The controller is a standard/product only S2 controller ESI Model 1812 with pneumatic cycle-counter. The controller is entirely pneumatic. The controller has a pair of adjustable pneumatic timers to control the on and off sequence of the pump. Each controller has it's own bubble type liquid level control. It consists of a ¼ inch tube that begins at a low-pressure source in the controller and terminates with an open end affixed to the exterior of the controller. Air "bubbling" transmits any change in back pressure caused by changing liquid level. The amount of air going to the pump then changes to increase water extraction rate. The pneumatic cycle-counter is used to calculate water flow rates from each extraction well.

Discharge hose, air line, and bubbler line are furnished with the pumps. The hose material is resistant to free product found in the extraction well.

Air requirements for the pneumatic pump and controller is approximately 0.7 scfm of compressed air per 1.0 gallon of extracted water.

#### **4.7 AIR COMPRESSOR**

The air compressors at the North and South Plants are two identical units. Each is capable of delivering 100 scfm of compressed air. These compressors were originally designed to handle additional wells. Expected flow rates from each new well is 2 gallons per minute or 1.4 scfm of air per well. Each Plant compressor was designed to handle 100 gallons per minute of extraction water. Figure 5 shows the air supply schematic.

## **5.0 OPERATION AND MAINTENANCE FOR WATER TREATMENT PLANTS**

---

Operation and maintenance consists of:

- System operation
- Optimization
- Maintenance and repair
- Sampling and analysis of influent, effluent, and treatment stages during troubleshooting activities.
- Recommendations for improving operations by improving on-stream times, reduce operating costs, and lower maintenance costs.
- Documentation

At this time, OHM does not foresee any requirement to amend the existing OHM manuals for the treatment system. As built drawings of the extraction system expansion will be provided at the completion of construction.

## **6.0 REPORTING**

---

The following paragraphs discuss reports OHM plans to prepare during the course of the project. Any other reports not mentioned in this section have not been deemed necessary.

### **6.1 WELL LOGS AND PERMITS**

Location and boring log data regarding installation of new recovery wells will be completed. The drilling subcontractor will complete the permit application.

### **6.2 ENVIRONMENTAL CONDITIONS REPORT**

Prior to starting any field activities at the project site, ROICC and OHM representative will tour the site, take photographs if needed and note any existing environmental conditions on or adjacent to the project site. This report will be submitted on a contractor's production report form included in the Quality Control Plan.

### **6.3 DAILY REPORTING**

OHM will prepare and submit daily Contractor's Production Reports and a Contractor's Quality Control Report each day that field activities are conducted or material is delivered for this project. It is anticipated that the site supervisor will perform the role of site QC manager during all periods when the designated site QC manager is not present at the job site.

### **6.3 AS-BUILT DRAWINGS**

Two sets of drawings will be maintained at OHM's field office at Camp Lejeune. These drawings will be updated as required for any deviation that has occurred. Upon completion of field activities, OHM will incorporate all changes into the record drawings for the project. Record drawings will accompany the submission of the Contractor's Closeout Report.

### **6.4 MONTHLY STATUS REPORT**

Monthly status reports (in the form and content previously approved by LANTDIV) will be submitted by the Program Office. Sections regarding progress, forecast, costs incurred, committed, delivery order modifications, waste tracking, and government materials tracking will be included. Schedules will be updated and variances explained.

### **6.5 CONTRACTOR CLOSEOUT REPORT**

OHM will supply a Contractor's Closeout Report that will summarize the construction of the remediation system. This report will include the following:

- A discussion of field changes and contract modifications,



- Photographic documentation,
- Rework items list and corrective actions taken (if required),
- Quality Control Daily Reports,
- On-site sample test results,
- Laboratory analyses results,
- Field daily reports,
- A final health and safety report,
- Quality assurance sample results,
- Contaminated soil disposal documentation including manifests, and
- “As-built drawings.

#### **6.6 OTHER DOCUMENTATION**

- Preconstruction Submittals
- Summary report of all analytical data
- QC Meeting Minutes/ QC Report
- Base Permits for: (1) Hot Work Permits and (2) Excavation Permits
- O&M quarterly reports will be prepared as a joint effort with the CLEAN contractor. OHM’s report section will deal with “in-plant activities”, recommendations, and conclusions. The CLEAN contractor will publish the report.

## ***7.0 PROJECT SCHEDULE***

---

The project schedule depicts the major tasks and durations to perform implementation of remedial action at the job site. Refer to the attached project schedule.

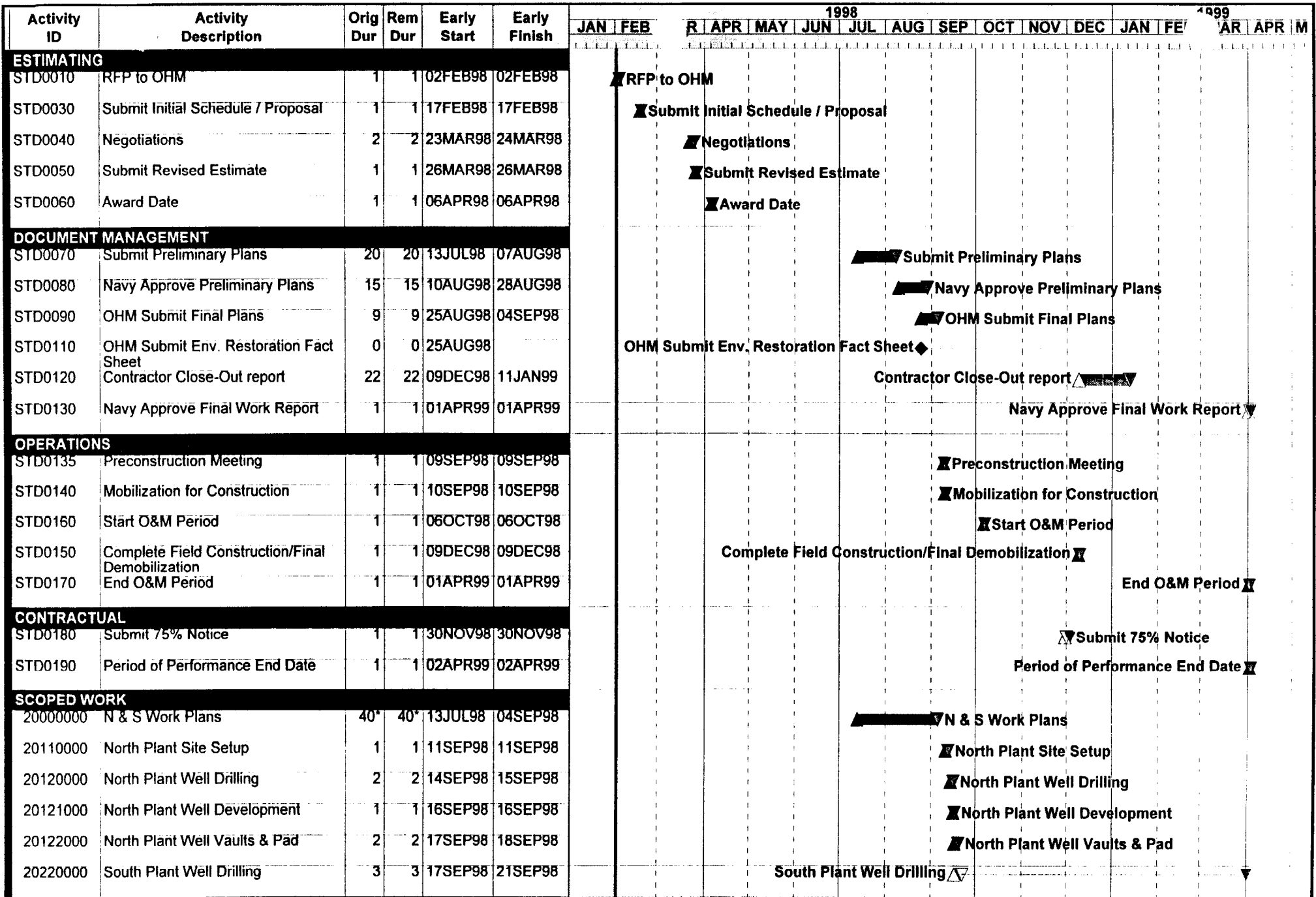

Project Start	02FEB98	▣ Early Bar
Project Finish	02APR99	▣ Float Bar
Data Date	02FEB98	▣ Progress Bar
Run Date	06AUG98	▣ Critical Activity

175B

**OHM Remediation Services**  
**Extension to Extraction Well System**  
**OU1 Site 78**

Sheet 1 of 2

20130000	North Plan GW Collection Piping	6	6	21SEP98	28SEP98					▲ North Plan GW Collection Piping
20221000	South Plant Well Development	2	2	22SEP98	23SEP98					▲ South Plant Well Development
20123000	North Plant Pumps & Instrumentation	3	3	29SEP98	01OCT98					▲ North Plant Pumps & Instrumentation
20124000	North Plant Well Electrical	1	1	02OCT98	02OCT98					▲ North Plant Well Electrical
20125000	North Plant Well Start Up	1	1	05OCT98	05OCT98					▲ North Plant Well Start Up
20140000	North Plant Disposal	1	1	06OCT98	06OCT98					▲ North Plant Disposal
20300000	N & S Plants O & M	123	123	06OCT98	31MAR99					▲ N & S Plants O & M
20400000	N & S Sampling & Analysis	123	123	06OCT98	31MAR99					▲ N & S Sampling & Analysis
20210000	South Plant Site set up	1	1	07OCT98	07OCT98					▲ South Plant Site set up
20222000	South Plant Well Vaults & Pads	3	3	08OCT98	12OCT98					▲ South Plant Well Vaults & Pads
20230000	South Plant GW Collection Piping	32	32	13OCT98	25NOV98					▲ South Plant GW Collection Piping
20223000	South Plant Pumps & Instrumentation	5	5	30NOV98	04DEC98					▲ South Plant Pumps & Instrumentation
20224000	South Plant Well Electrical	1	1	07DEC98	07DEC98					▲ South Plant Well Electrical
20225000	South Plant Well Start Up	1	1	08DEC98	08DEC98					▲ South Plant Well Start Up
20500000	N & S Final Report	22*	22*	09DEC98	11JAN99					▲ N & S Final Report

00195BBB1Z

# HADNOT POINT INDUSTRIAL AREA SHALLOW AQUIFER GROUNDWATER TREATMENT SYSTEM

MARINE CORPS BASE  
CAMP LEJEUNE, NORTH CAROLINA  
ATLANTIC DIVISION, NORFOLK, VIRGINIA

DRAFT

INDEX OF SHEETS

SHEET NO.	TITLE
FIGURE-1	COVER SHEET AND VICINITY MAP
FIGURE-2	NEW PIPING PLAN - SOUTH REMEDIATION AREA
FIGURE-3	NEW PIPING PLAN - NORTH REMEDIATION AREA
FIGURE-4	EXTRACTION WELL DETAIL
FIGURE 5	AIR SUPPLY SCHEMATIC

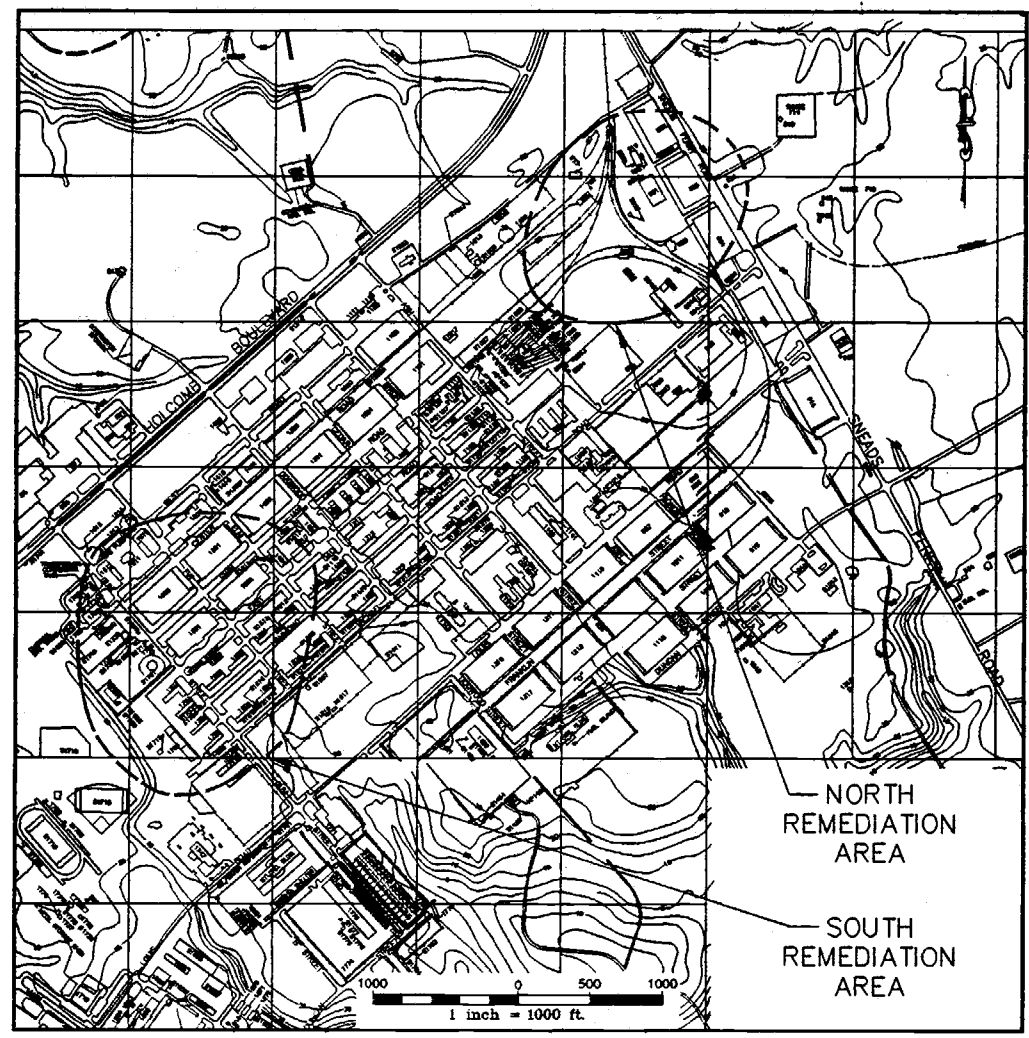

VICINITY MAP

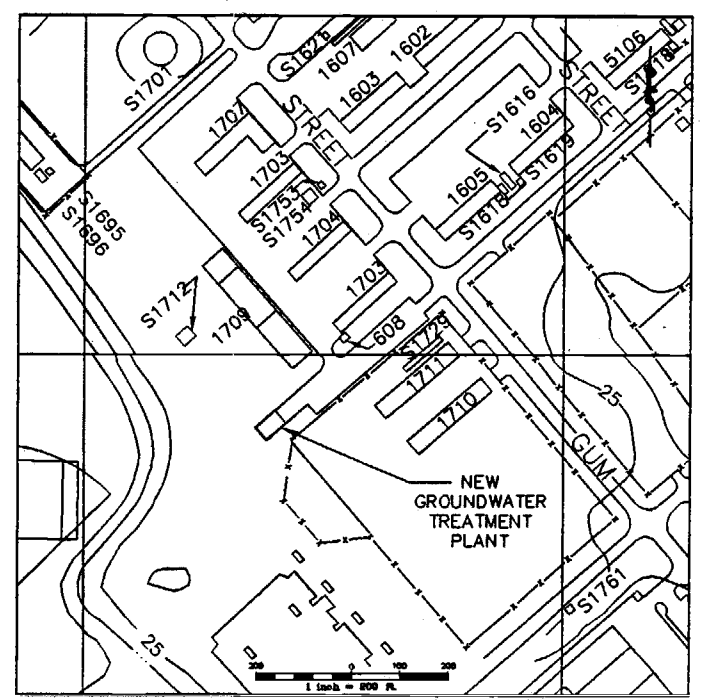

LOCATION MAP  
SOUTH REMEDIATION AREA  
NEW GROUNDWATER TREATMENT PLANT

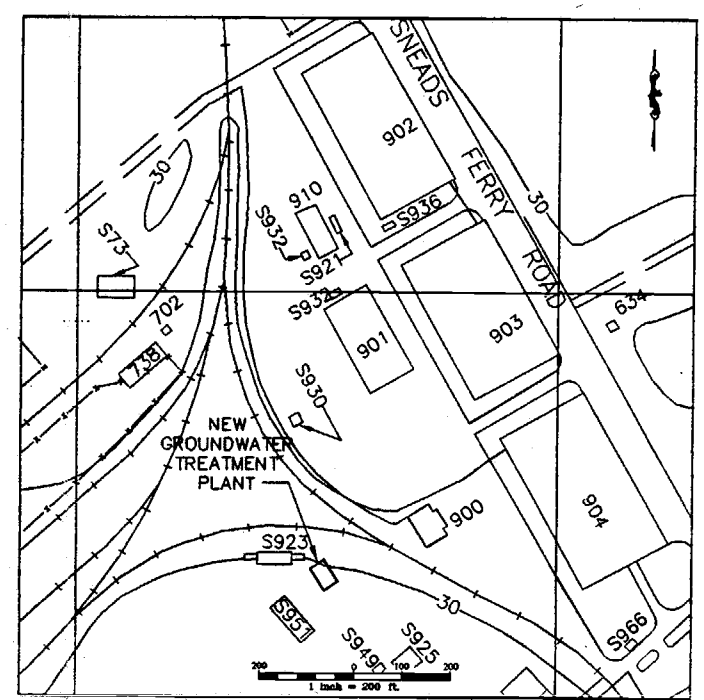

LOCATION MAP  
NORTH REMEDIATION AREA  
NEW GROUNDWATER TREATMENT PLANT

SOURCE: SHALLOW AQUIFER GROUNDWATER TREATMENT, DRAWING T-1, BAKER ENVIRONMENTAL INC.

**OHM Remediation Services Corp.**  
Norcross, Georgia  
A Subsidiary of OHM Corporation

SUBMITTED: \_\_\_\_\_ PROJECT MANAGER: \_\_\_\_\_ DATE: \_\_\_\_\_  
APPROVED: \_\_\_\_\_ SR. PROJECT ENGINEER: \_\_\_\_\_ DATE: \_\_\_\_\_  
APPROVED: \_\_\_\_\_ DEPT. MANAGER: \_\_\_\_\_ DATE: \_\_\_\_\_

AT FULL SCALE (IF NOT 1"=SCALE ACCORDINGLY)		ZONE	REV.	DESCRIPTION	BY	DATE	APP.
CADD FILE:			0	WORK PLAN		7/1/98	
DRAWN: J. LANGE							
DESIGNED: PAUL MATZ							
CHECKED: TOM McCORRY							
CHECKED: JIM DUNN							

DEPARTMENT OF THE NAVY NAVAL FACILITIES ENGINEERING COMMAND  
**ATLANTIC DIVISION**  
NAVAL STATION NORFOLK, VIRGINIA  
CONTRACT N62470-93-D-3032 DELIVERY ORDER NO. 0175  
OHM PROJECT No. 20500 MARINE CORPS BASE, CAMP LEJEUNE, N.C.

FIGURE 1  
COVER SHEET AND VICINITY MAP

DRAWING NUMBER: \_\_\_\_\_  
SHEET NUMBER: \_\_\_\_\_ of \_\_\_\_\_  
DATE: 8/04/98

J:\LANDVA\LEJEUNE\205000\WP\FIG-1.DWG

- UTILITY NOTES:**
1. ALL GRAVITY SEWERS ARE TERRA COTTA UNLESS NOTED OTHERWISE.
  2. ALL SERVICE LINES IN 1100 & 1200 AREAS ARE 4" UNLESS NOTED OTHERWISE.
  3. MATERIAL OF CONSTRUCTION  
CI - CAST IRON
  4. ALL WATER MAINS ARE CAST IRON UNLESS NOTED OTHERWISE.
  5. ALL WATER SERVICE LINES IN 1100, 1200, & 1300 AREA ARE 3/4" UNLESS NOTED OTHERWISE.
  6. ALL STEAM PIPING IS SCHEDULE 80 STEEL. CONDENSATE PIPING IS SCHEDULE 80 STEEL UNLESS NOTED OTHERWISE.
  7. PIPE INSULATION THICKNESS AND TYPE:  
STEAM - 2" FIBERGLASS  
CONDENSATE - FIBERGLASS
- SOURCE: LANTRON, OCT. 1991

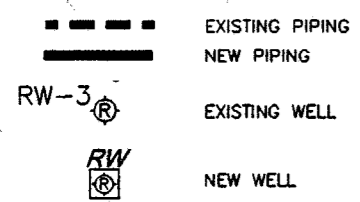

NOTE:  
NEW PIPING WILL BE FIELD DETERMINED BASED ON LOCATION OF UTILITIES

HYDROGEOLOGIST WILL DETERMINE EXACT LOCATION OF WELLS DURING DRILLING ACTIVITIES

RW-13 IS LOCATED 80' ACROSS AND 25' DOWN FROM BUILDING 1707

2" DIA HDPE CARRIER PIPE  
1" DIA HDPE AIR PIPE  
SEE FIGURE 4

POINT OF REFERENCE  
RW-15 IS LOCATED 99' ACROSS AND 19' DOWN FROM BUILDING 1502

POINT OF REFERENCE  
RW-13

RW-14 IS LOCATED 15' DOWN AND 70' ACROSS FROM BUILDING 1607

1" DIA. POTABLE SERVICE WATER LINE

GROUNDWATER TREATMENT PLANT

CONNECT NEW 1" DIA. POTABLE SERVICE WATER LINE TO EXISTING 2" DIA. WATER LINE USING A COPPERATION STOP AND DISCONNECT

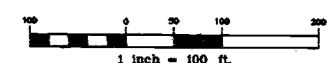
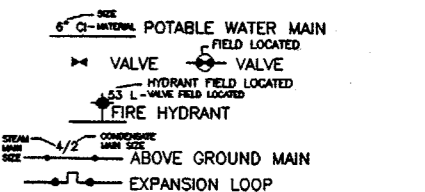
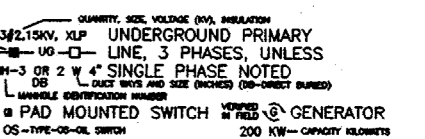
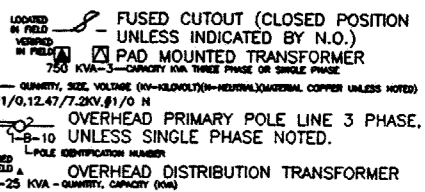
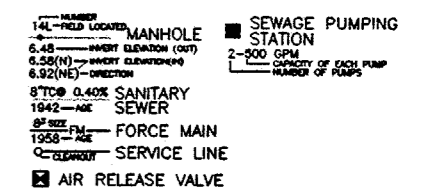
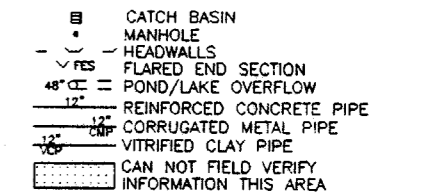

**DRAFT**

SOURCE: SHALLOW AQUIFER GROUNDWATER TREATMENT, DRAWING C-3, BAKER ENVIRONMENTAL INC.

**OHM Remediation Services Corp.**  
Norcross, Georgia  
A Subsidiary of OHM Corporation

SUBMITTED: \_\_\_\_\_ PROJECT MANAGER: \_\_\_\_\_ DATE: \_\_\_\_\_  
APPROVED: \_\_\_\_\_ SR. PROJECT ENGINEER: \_\_\_\_\_ DATE: \_\_\_\_\_  
APPROVED: \_\_\_\_\_ DEPT. MANAGER: \_\_\_\_\_ DATE: \_\_\_\_\_

REVISIONS						
ZONE	REV.	DESCRIPTION	BY	DATE	APP.	
	0	WORK PLAN		7/1/98		

AT FULL SCALE (IF NOT 1"=SCALE ACCORDINGLY)
CADD FILE: _____
DRAWN: J. LANGE
DESIGNED: PAUL MATZ
CHECKED: TOM McCORRY
CHECKED: JIM DUNN

DEPARTMENT OF THE NAVY NAVAL FACILITIES ENGINEERING COMMAND

**ATLANTIC DIVISION**

NAVAL STATION NORFOLK, VIRGINIA

CONTRACT N62470-93-D-3032 DELIVERY ORDER NO. 0175

OHM PROJECT No. 20500 MARINE CORPS BASE, CAMP LEJEUNE, N.C.

**FIGURE 2**

**NEW PIPING PLAN- SOUTH REMEDIATION AREA**

DRAWING NUMBER: \_\_\_\_\_

SHEET NUMBER: \_\_\_\_\_ of \_\_\_\_\_

DATE: 8/04/98

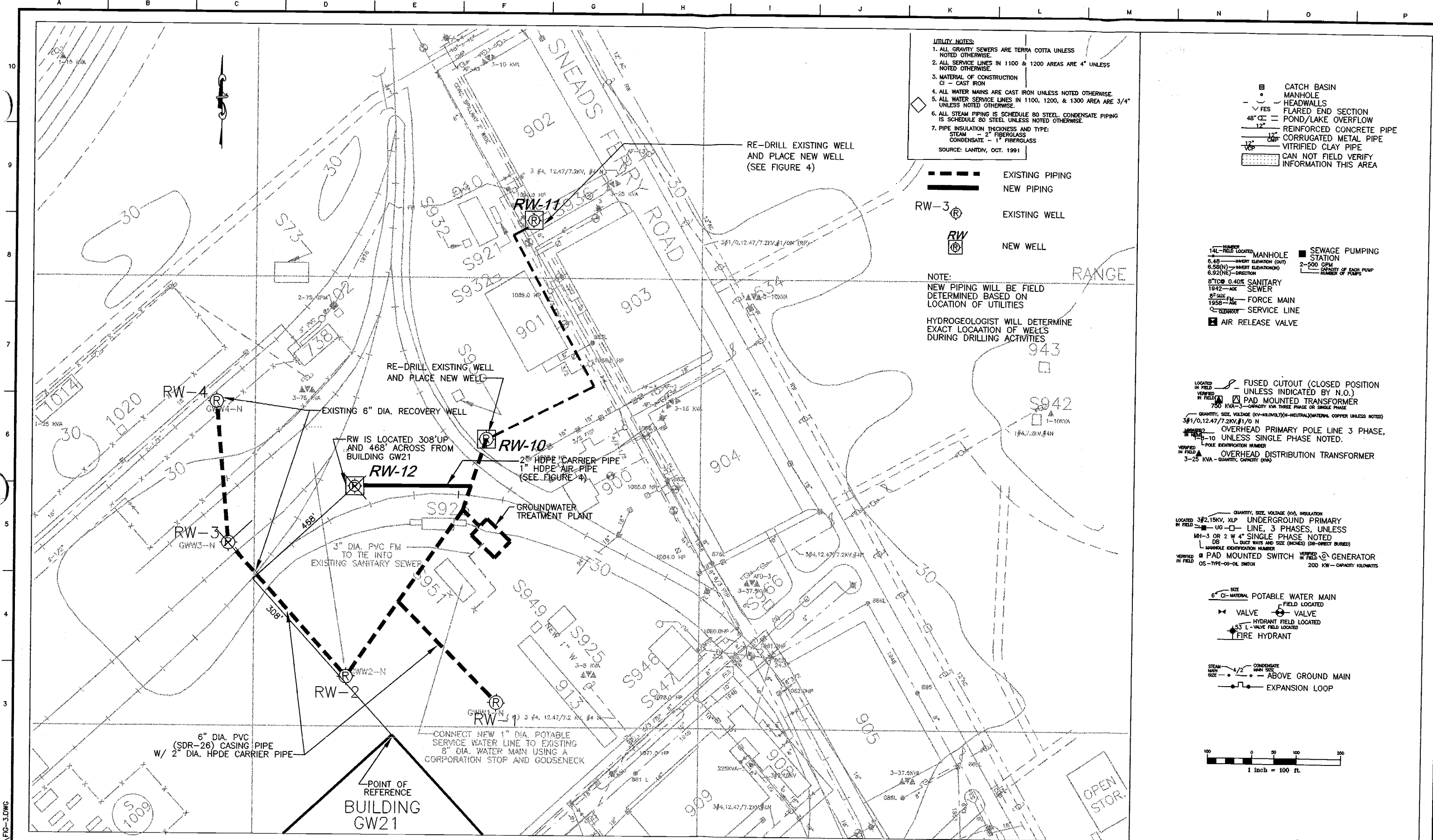

- UTILITY NOTES:**
1. ALL GRAVITY SEWERS ARE TERRA COTTA UNLESS NOTED OTHERWISE.
  2. ALL SERVICE LINES IN 1100 & 1200 AREAS ARE 4" UNLESS NOTED OTHERWISE.
  3. MATERIAL OF CONSTRUCTION  
CI - CAST IRON
  4. ALL WATER MAINS ARE CAST IRON UNLESS NOTED OTHERWISE.
  5. ALL WATER SERVICE LINES IN 1100, 1200, & 1300 AREA ARE 3/4" UNLESS NOTED OTHERWISE.
  6. ALL STEAM PIPING IS SCHEDULE 80 STEEL. CONDENSATE PIPING IS SCHEDULE 80 STEEL UNLESS NOTED OTHERWISE.
  7. PIPE INSULATION THICKNESS AND TYPE:  
STEAM - 2" FIBERGLASS  
CONDENSATE - 1" FIBERGLASS
- SOURCE: LANTRON, OCT. 1991

- EXISTING PIPING  
NEW PIPING
- RW-3  
EXISTING WELL
- RW  
NEW WELL

NOTE:  
NEW PIPING WILL BE FIELD DETERMINED BASED ON LOCATION OF UTILITIES

HYDROGEOLOGIST WILL DETERMINE EXACT LOCATION OF WELLS DURING DRILLING ACTIVITIES

- MANHOLE
- HEADWALLS
- FLARED END SECTION
- POND/LAKE OVERFLOW
- REINFORCED CONCRETE PIPE
- CORRUGATED METAL PIPE
- VITRIFIED CLAY PIPE
- CAN NOT FIELD VERIFY INFORMATION THIS AREA

- SEWAGE PUMPING STATION
- 2-500 GPM CAPACITY OF EACH PUMP
- NUMBER OF PUMPS
- MANHOLE
- INVERT ELEVATION (OUT)
- INVERT ELEVATION (IN)
- DIRECTION
- 0.40X SANITARY SEWER
- FORCE MAIN
- SERVICE LINE
- AIR RELEASE VALVE

- FUSED CUTOUT (CLOSED POSITION UNLESS INDICATED BY N.O.)
- PAD MOUNTED TRANSFORMER
- 3-30 KVA-3-CAPACITY 3 PHASE OR SINGLE PHASE
- OVERHEAD PRIMARY POLE LINE 3 PHASE, UNLESS SINGLE PHASE NOTED.
- OVERHEAD DISTRIBUTION TRANSFORMER
- 3-25 KVA - QUANTITY, CAPACITY (KVA)

- UNDERGROUND PRIMARY LINE, 3 PHASES, UNLESS SINGLE PHASE NOTED
- DUCT WAYS AND SIZE (INCHES) (DG-DIRECT BURIED)
- PAD MOUNTED SWITCH
- 200 KW - CAPACITY KILOWATTS

- POTABLE WATER MAIN
- VALVE
- VALVE
- HYDRANT FIELD LOCATED
- VALVE FIELD LOCATED
- FIRE HYDRANT
- CONDENSATE MAIN
- ABOVE GROUND MAIN
- EXPANSION LOOP

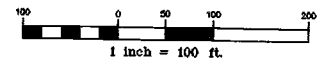

SOURCE: SHALLOW AQUIFER GROUNDWATER TREATMENT, DRAWING C-1, BAKER ENVIRONMENTAL INC.

**OHM Remediation Services Corp.**  
Norcross, Georgia  
A Subsidiary of OHM Corporation

SUBMITTED: \_\_\_\_\_ PROJECT MANAGER: \_\_\_\_\_ DATE: \_\_\_\_\_  
APPROVED: \_\_\_\_\_ SR. PROJECT ENGINEER: \_\_\_\_\_ DATE: \_\_\_\_\_  
APPROVED: \_\_\_\_\_ DEPT. MANAGER: \_\_\_\_\_ DATE: \_\_\_\_\_

AT FULL SCALE (IF NOT 1"=SCALE ACCORDINGLY)		REVISIONS			
ZONE	REV.	DESCRIPTION	BY	DATE	APP.
	0	WORK PLAN		7/1/98	
	1	REVISE LOCATION OF RW-11		9/24/98	

DEPARTMENT OF THE NAVY NAVAL FACILITIES ENGINEERING COMMAND

**ATLANTIC DIVISION**

NAVAL STATION NORFOLK, VIRGINIA

CONTRACT N82470-93-D-3032 DELIVERY ORDER NO. 0175

OHM PROJECT No. 20500 MARINE CORPS BASE, CAMP LEJEUNE, N.C.

**FIGURE 3**

**NEW PIPING PLAN- NORTH REMEDIATION AREA**

DRAWING NUMBER: \_\_\_\_\_

SHEET NUMBER: \_\_\_\_\_ of \_\_\_\_\_

DATE: 8/04/98

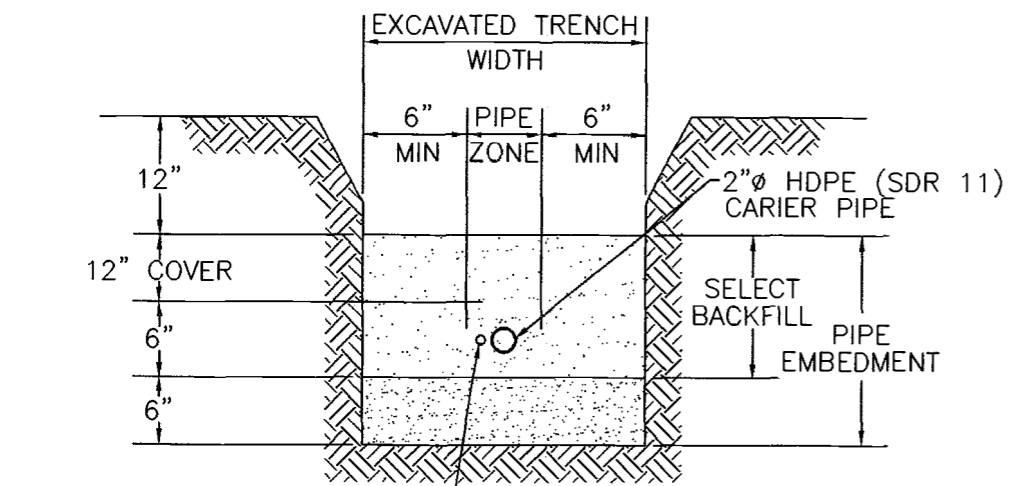

1"  $\phi$  HDPE AIRLINE - AIRPRO (SYSTEM POWER AIR)  
 ALL BACKFILL COMPACTED TO 95% STANDARD PROCTOR

TYPICAL NEW PIPE INSTALLATION  
 N.T.S.

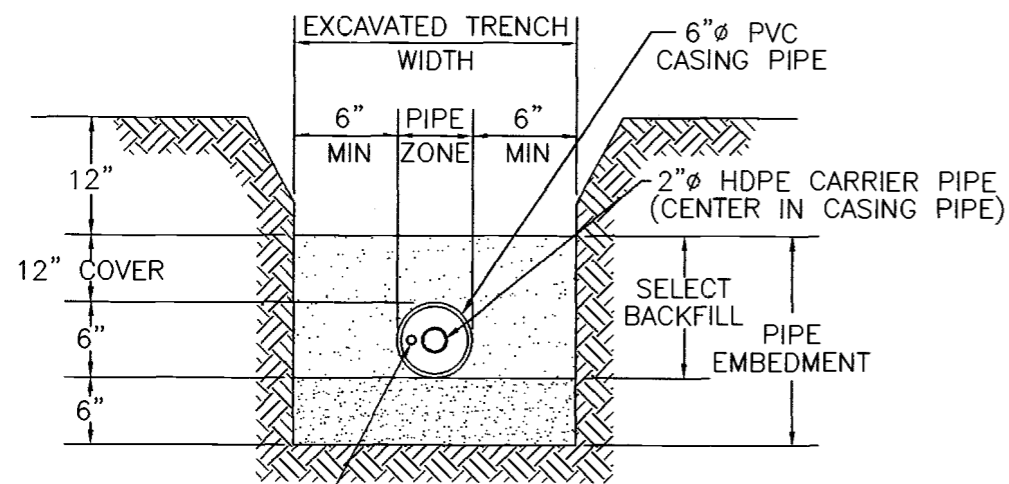

3/4"  $\phi$  AIRLINE (SYSTEM POWER AIR)  
 ALL BACKFILL COMPACTED TO 95% STANDARD PROCTOR

EXISTING PIPE INSTALLATION  
 N.T.S.

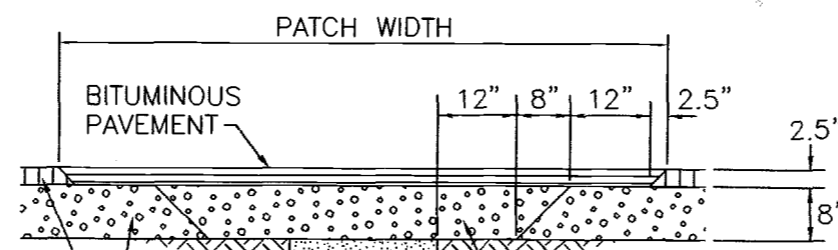

EXISTING PAVEMENT  
 EXISTING BASE  
 COMPACTED SUBGRADE  
 BITUMINOUS PAVEMENT  
 STONE BASE COURSE FINE AGGREGATE, STANDARD SIZE #4, MEETING THE GRADATION REQUIREMENTS OF NC DOT.

PAVEMENT PATCHING  
 N.T.S.

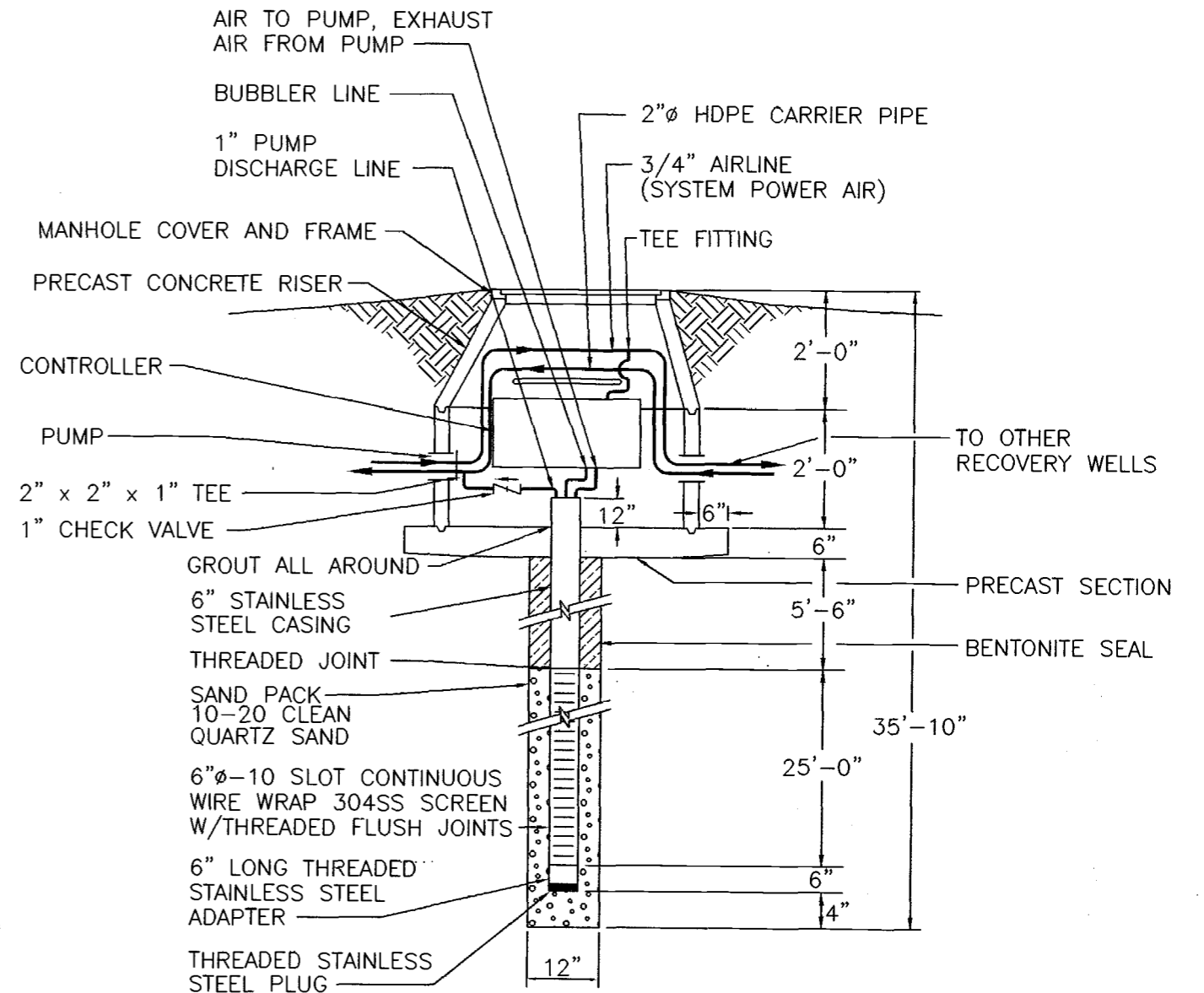

RECOVERY WELL DETAIL  
 N.T.S.

FOLLOW PIPING PLAN FROM EXISTING WELLS

SOURCE: SHALLOW AQUIFER GROUNDWATER TREATMENT, DRAWING C-8, BAKER ENVIRONMENTAL INC.



AT FULL SCALE (IF NOT 1"=SCALE ACCORDINGLY)		REVISIONS				
CADD FILE:	ZONE	REV.	DESCRIPTION	BY	DATE	APP.
DRAWN: J. LANGE	0	0	WORK PLAN		7/1/98	
DESIGNED: PAUL MATZ	1	1	ADDED TOTAL DIMENSION TO WELL DETAIL		9/24/98	
CHECKED: TOM McCORORY						
CHECKED: JIM DUNN						

DEPARTMENT OF THE NAVY NAVAL FACILITIES ENGINEERING COMMAND  
**ATLANTIC DIVISION**  
 NAVAL STATION NORFOLK, VIRGINIA  
 CONTRACT N62470-93-D-3032 DELIVERY ORDER NO. 0175  
 OHM PROJECT No. 20500 MARINE CORPS BASE, CAMP LEJEUNE, N.C.

FIGURE 4  
**EXTRACTION WELL DETAILS**

DRAWING NUMBER:  
 SHEET NUMBER:  
 of  
 DATE:  
 8/04/98

J:\LANDVA\LEJEUNE\20500\WP\FIG-4.DWG



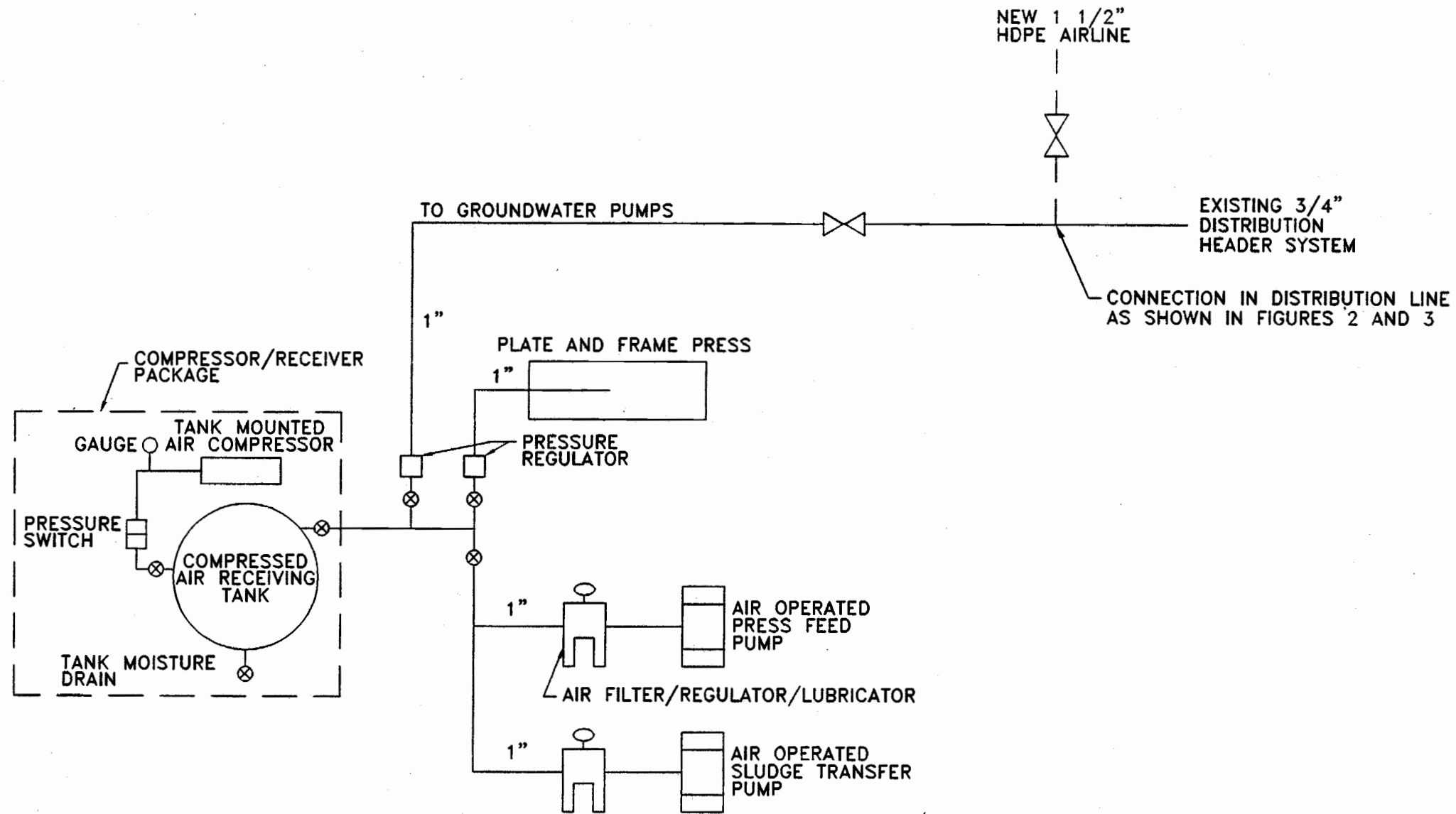

EXISTING AIR SUPPLY SCHEMATIC  
N.T.S.

DRAFT

SOURCE: SHALLOW AQUIFER GROUNDWATER TREATMENT. DRAWING C-9, BAKER ENVIRONMENTAL INC.

**OHM Remediation Services Corp.**  
Norcross, Georgia  
A Subsidiary of OHM Corporation

SUBMITTED: \_\_\_\_\_ PROJECT MANAGER DATE: \_\_\_\_\_  
APPROVED: \_\_\_\_\_ PROJECT ENGINEER DATE: \_\_\_\_\_  
APPROVED: \_\_\_\_\_ LEAD MANAGER DATE: \_\_\_\_\_

AT FULL SCALE (IF NOT 1"=SCALE ACCORDINGLY)		REVISIONS				
ZONE	REV.	DESCRIPTION	BY	DATE	APP.	
	0	WORK PLAN		7/1/98		

DEPARTMENT OF THE NAVY NAVAL FACILITIES ENGINEERING COMMAND  
**ATLANTIC DIVISION**  
NAVAL STATION NORFOLK, VIRGINIA  
CONTRACT N62470-93-D-3032 DELIVERY ORDER NO. 0175  
OHM PROJECT No. 20500 MARINE CORPS BASE, CAMP LEJEUNE, N.C.

**FIGURE 5**  
**AIR SUPPLY SCHEMATIC**

DRAWING NUMBER: \_\_\_\_\_  
SHEET NUMBER: \_\_\_\_\_ of \_\_\_\_\_  
DATE: 8/04/98

J:\1\ANIND\1\EJUNE\207041\WP\FIC-5.DWG

**SITE-SPECIFIC HEALTH AND SAFETY PLAN  
FOR  
CONSTRUCTION OF NEW WELLS  
AT HADNOT POINT INDUSTRIAL AREA  
NORTH AND SOUTH GROUNDWATER TREATMENT PLANS  
MCB CAMP LEJEUNE, NORTH CAROLINA**

Prepared for:

DEPARTMENT OF THE NAVY  
Contract No. N62470-93-D-3032  
Atlantic Division  
Naval Facilities Engineering Command  
6500 Hampton Boulevard  
Building A (South East Wing) 3<sup>rd</sup> Floor  
Norfolk, VA 23508

Prepared by

OHM Remediation Services Corp.  
Norcross, Georgia

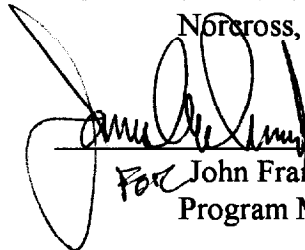
  
For John Franz, P.E.  
Program Manager

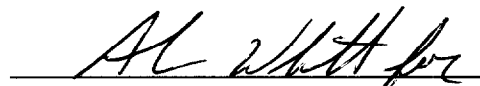
  
James A. Dunn, Jr., P.E.  
Senior Project Manager

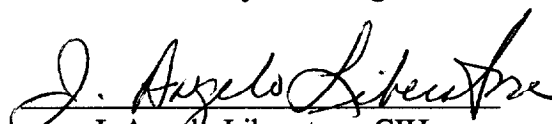
  
J. Angelo Liberatore, CIH  
LANTDIV Health and Safety Director

September 1998  
Delivery Order 0175  
OHM Project No. 20500

## **TABLE OF CONTENTS**

---

<b>1.0 INTRODUCTION.....</b>	<b>1-1</b>
1.1 SITE HISTORY AND DESCRIPTION .....	1-1
1.2 SCOPE OF WORK.....	1-1
<b>2.0 KEY PERSONNEL AND MANAGEMENT.....</b>	<b>2-1</b>
2.1 PROJECT MANAGER .....	2-1
2.2 SITE SUPERVISOR.....	2-1
2.3 SITE SAFETY OFFICER .....	2-1
2.4 CERTIFIED INDUSTRIAL HYGIENIST.....	2-1
2.5 EMPLOYEE SAFETY RESPONSIBILITY .....	2-2
2.6 KEY SAFETY PERSONNEL .....	2-2
<b>3.0 JOB HAZARD ANALYSIS.....</b>	<b>3-1</b>
3.1 CHEMICAL HAZARDS.....	3-1
3.2 PHYSICAL HAZARDS .....	3-3
3.3 ENVIRONMENTAL HAZARDS.....	3-6
3.4 TASK-SPECIFIC RISK ASSESSMENT/ACTIVITY HAZARD ANALYSIS.....	3-9
<b>4.0 WORK AND SUPPORT AREAS.....</b>	<b>4-1</b>
4.1 EXCLUSION ZONE .....	4-1
4.2 CONTAMINATION REDUCTION ZONE.....	4-1
4.3 SUPPORT ZONE .....	4-1
4.4 SITE CONTROL LOG.....	4-1
4.5 GENERAL.....	4-2
<b>5.0 PROTECTIVE EQUIPMENT .....</b>	<b>5-1</b>
5.1 ANTICIPATED PROTECTION LEVELS .....	5-1
5.2 PROTECTION LEVEL DESCRIPTIONS.....	5-1
5.3 SUPPLIED-AIR RESPIRATORS .....	5-2
5.5 AIR-PURIFYING RESPIRATORS .....	5-3
5.6 RESPIRATOR CARTRIDGES .....	5-3
5.7 CARTRIDGE CHANGES.....	5-3
5.8 INSPECTION AND CLEANING .....	5-3
5.9 FIT TESTING.....	5-3
5.10 FACIAL HAIR .....	5-3
5.11 CORRECTIVE LENSES.....	5-4
5.12 CONTACT LENSES.....	5-4
5.13 MEDICAL CERTIFICATION .....	5-4
5.14 SITE-SPECIFIC RESPIRATORY PROTECTION PROGRAM.....	5-4
<b>6.0 DECONTAMINATION PROCEDURES.....</b>	<b>6-1</b>
6.1 PERSONNEL DECONTAMINATION .....	6-1
6.1.2 Personal Hygiene .....	6-1
6.2 EQUIPMENT DECONTAMINATION .....	6-1
6.3 DISPOSAL .....	6-2
<b>7.0 AIR MONITORING.....</b>	<b>7-1</b>
7.1 LOWER EXPLOSIVE LIMIT/OXYGEN (LEL/O <sub>2</sub> ) METER.....	7-1
7.2 PHOTOIONIZATION DETECTOR (PID).....	7-1

**TABLE OF CONTENTS**

---

7.3 AIR MONITORING LOG..... 7-2  
7.4 CALIBRATION REQUIREMENTS..... 7-2  
7.5 AIR MONITORING RESULTS..... 7-2  
**8.0 EMERGENCY RESPONSE..... 8-1**  
8.1 PRE-EMERGENCY PLANNING..... 8-1  
8.2 EMERGENCY RECOGNITION AND PREVENTION..... 8-2  
8.3 PERSONNEL ROLES, LINES OF AUTHORITY, AND COMMUNICATIONS . 8-4  
8.4 SAFE DISTANCES AND PLACES OF REFUGE ..... 8-7  
8.5 EVACUATION ROUTES AND PROCEDURES ..... 8-7  
8.6 EMERGENCY SPILL RESPONSE PROCEDURES AND EQUIPMENT ..... 8-9  
8.7 EMERGENCY CONTINGENCY PLAN ..... 8-13  
**9.0 TRAINING REQUIREMENTS ..... 9-1**  
**10.0 MEDICAL SURVEILLANCE PROGRAM ..... 10-1**  
10.1 EXAMINATION SCHEDULE ..... 10-1

**APPENDICES**

*SPACE MORE*

- APPENDIX A HEALTH AND SAFETY CERTIFICATION
- APPENDIX B OHM HAZARD COMMUNICATION PROGRAM
- APPENDIX C SITE MATERIAL SAFETY DATA SHEETS
- APPENDIX D SPECIFIC OHM HEALTH AND SAFETY PROCEDURES
- APPENDIX E HEALTH AND SAFETY FORMS

## **1.0 INTRODUCTION**

---

This Health and Safety Plan (HASP) has been developed for United States Navy, LANTDIV, Delivery Order 0175 for the installation of additional extraction wells at Operable Unit No.1, Site 78, Camp Lejeune, North Carolina. This work will be executed per the requirements stated in the Delivery Order under Contract No. N62470-93-D-3032.

This HASP documents the policies and procedures which protect workers and the public from potential hazards posed by work at this site. OHM considers safety the highest priority during work at a site containing potentially hazardous materials and has established a goal of zero accidents for all projects. All projects will be conducted in a manner which minimizes the probability of injury, accident, or incident occurrence. This HASP is a key element in the proper planning of project work which is necessary to assure the goal of zero accidents. The HASP Certification (Appendix A) will be signed by all who actively participate at this project.

Although this plan focuses on the specific work activities planned for this site, it must remain flexible because of the nature of this work. Conditions may change and unforeseen situations may arise that require deviations from the original plan. This flexibility allows modification by the OHM supervisors and health and safety officials with approval from the project CIH.

This plan has been prepared in accordance with OSHA's "Hazardous Waste Operations and Emergency Response" standard contained in 29 CFR 1910.120 and the U. S. Army Corps of Engineer's (USACE's) Safety and Health Requirements Manual (COE EM-385-1-1, September 1996).

### **1.1 SITE HISTORY AND DESCRIPTION**

The remediation system at Operable unit No.1, Site 78, consists of two pump and treat plants located in the Hadnot Point Industrial Area (HPIA) of Camp Lejeune. These plants are generally referred to as the North and South plants. Both plants were constructed based on the results of site remedial investigations that identified petroleum and chlorinated hydrocarbon contamination in groundwater. These plants have been in operation since 1994. Site 78 is comprised of approximately 75 buildings and facilities including maintenance shops, gas stations, administrative offices, commissaries, snack bars, warehouse and storage yards. Due to the industrial nature of the site, many spills and keaks have occurred over the years. Most spills and leaks have involved petroleum-related products and solvents from underground storage tanks (UST's), drums and uncontrolled waste storage areas.

### **1.2 SCOPE OF WORK**

The project consists of installing additional extraction wells and operation and maintenance of the water treatment facility. The following tasks will be performed:

- Task 1: Mobilization and site preparation
- Task 2: Drill and install extraction wells and well vaults

- Task 3: Well abandonment
- Task 4: Well development
- Task 5: Jack and bore installation
- Task 6: Trench and install piping/well head for system
- Task 7: Installation of power, control and associated electrical equipment for system
- Task 8: Equipment installation and plumbing for system
- Task 9: System startup and testing
- Task 10: System operation and maintenance
- Task 11: Collect liquid samples
- Task 12: Decontaminate equipment
- Task 13: Demobilization

These activities have been analyzed for potential hazards for which hazard control measures are provided in Section 3.4 Activity Hazard Analysis.

## **2.0 KEY PERSONNEL AND MANAGEMENT**

---

The Project Manager (PM), Site Supervisor (SS), Certified Industrial Hygienist (CIH) and Site Safety Officer (SSO) are responsible for formulating and enforcing health and safety requirements, and implementing the HASP.

### **2.1 PROJECT MANAGER**

The PM has the overall responsibility for the project and to assure that the goals of the construction remedial action are attained in a manner consistent with the HASP requirements. The PM will coordinate with the SS and the SSO to assure that the remedial action goals are completed in a manner consistent with the HASP. The PM will identify contacts and telephone numbers, with assistance from LANTDIV, of local health care providers, the NOSC/NOSCDR, the LEPC and other agencies that may be asked to provide emergency support during project activities. The PM will conduct a monthly health and safety audit of the project using the Management Health and Safety Report Form.

### **2.2 SITE SUPERVISOR**

The SS is responsible for field implementation of the HASP. The SS will coordinate with the SSO to establish communications with local health care providers, the NOSC/NOSCDR, the LEPC and other outside organizations and agencies that may be asked to provide emergency support during project activities. The SS will be the main contact in any on-site emergency situation. The SS will conduct periodic inspection of the work site to confirm compliance with all health and safety requirements. The SS is also responsible for coordinating remedial actions for all deficiencies and for enforcing the OHM "Cardinal Safety Rules" (included in Appendix E) and the site specific health and safety procedures (included in Appendix B).

### **2.3 SITE SAFETY OFFICER**

The SSO has responsibility for administering the HASP relative to site activities, and will be in the field full-time while site activities are in progress. The SSO's primary operational responsibilities include personal and environmental monitoring, coordination of job safety analyses, personal protective equipment maintenance, and assignment of protection levels. The SSO will direct all field activities involved with safety and is authorized to stop work when an imminent health or safety risk exists. The SSO is responsible for assuring that all on-site personnel understand all safety requirements.

### **2.4 CERTIFIED INDUSTRIAL HYGIENIST**

The CIH is responsible for the contents of the HASP and ensures that the HASP complies with all federal, state and local health and safety requirements. If necessary, the CIH can modify specific aspects of the HASP to adjust for on-site changes that affect safety. The CIH will coordinate with the SSO on all modifications to the HASP and will be available for consultation when required. The CIH will not necessarily be on site during OHM activities; however, he may perform site safety audits to confirm field compliance with the HASP.

## 2.5 EMPLOYEE SAFETY RESPONSIBILITY

Each employee is responsible for personal safety as well as the safety of others in the area. The employee will use all equipment provided in a safe and responsible manner as directed by the SS. All OHM personnel will follow the policies set forth in OHM's Health and Safety Procedures Manual, with particular emphasis on the OHM "Cardinal Safety Rules." which will be maintained on-site by the site safety officer. Specific health and safety procedures applicable to this project are provided in Appendix D of this plan.

## 2.6 KEY SAFETY PERSONNEL

The following individuals share responsibility for health and safety at the site.

Project Manager	James A. Dunn, Jr. (770) 734-8072 (Office) (800) 999-6710 (Pager) 9968061 Pin
Site Supervisor	Randy Smith (910) 451-2390 (Office) (910) 346-7110 (Pager)
Site Safety Officer	Alison Harwood (252) 444-8302
Program Manager for LANTDIV	John Franz, P.E. (609) 588-6477
SR Health and Safety Director/Project CIH	J. Angelo Liberatore, CIH (770) 453-7671 (office) 1-800-999-6710 PIN 997-6102 (pager)



### 3.0 JOB HAZARD ANALYSIS

---

This section outlines the potential chemical and physical hazards which workers may be exposed to during work on this project. Table 3.1 lists significant contaminants identified at the site and their respective published occupational exposure limits. The OSHA permissible exposure limits (PELs) and the ACGIH threshold limit values (TLVs) were reviewed for these contaminants, evaluated, and the more stringent value of the two selected as exposure guidelines. An MSDS list is included in Appendix C.

#### 3.1 CHEMICAL HAZARDS

##### ***Petroleum Hydrocarbons Products (Organic Solvents)***

*Gasoline - Threshold Limit Value - 300 ppm*

*Diesel - NA*

*Kerosene - NA*

*Fuel Oil No. 2 - NA*

Petroleum products can cause dry skin, irritation, anesthetic effects, loss of coordination, central nervous system depression, and death. Overexposure may cause an exaggerated sense of well being, excitement, headache, dizziness, incoherent speech, narcosis, central nervous system stimulation and then depression, respiratory paralysis, respiratory irritation, vomiting, skin cancer, and death. Fuels have been associated with skin and kidney cancer.

Gasoline is a clear, colorless (dye may be added for color), flammable liquid with an aromatic odor. It will form flammable mixtures with air at -45°F. Vapors are heavier than air with a vapor density of 3 to 4 (air = 1), and the liquid is lighter than water with a specific gravity of 0.72 to 0.76 (water = 1). It is extremely flammable and vapors can travel great distances to an ignition source and flash back to the source.

Kerosene is a clear, colorless (dye may be added for color), combustible liquid with a kerosene-like odor. It will form flammable mixtures with air at 130°F. Vapors are heavier than air with a vapor density of 5 to 4 (air = 1), and the liquid is lighter than water with a specific gravity of 0.943 (water = 1). It is flammable and vapors can travel great distances to an ignition source and flash back to the source.

##### ***Benzene Permissible Exposure Limit – 1 ppm***

Benzene is listed as a cancer-causing substance. Liquid contact with skin or eyes causes painful irritation and possible burns. Vapors may cause irritation of the eyes, nose, and throat; dizziness; headache; slurred speech; double vision; central nervous system depression; coma, leukemia and death.

Benzene is a clear, colorless, volatile liquid with a sweet aromatic odor. Odor is not a good warning. Benzene will form flammable vapor-air mixtures at approximately 12°F. The vapor is heavier than air with a vapor density of 2.7 (air = 1) and the liquid is lighter than water with a specific gravity of 0.87 (water = 1).

***Toluene      Threshold Limit Value – 400 ppm***

Toluene overexposure may cause irritation of the eyes, respiratory tract, and skin; headache; dermatitis; dizziness; fatigue; incoordination; central nervous system depression; coma; and death. Liquid splashed in the eyes may cause irritation and damage.

Toluene is a clear, colorless, flammable liquid with an aromatic odor. It will form flammable mixtures with air at 53°F. Vapors are heavier than air with a vapor density of 3.14 (air = 1) and the liquid is lighter than water with a specific gravity of 0.78 (water = 1.1).

***Ethyl Benzene Permissible Exposure limit – 100 ppm***

Ethyl benzene overexposure may cause irritation of the eyes, respiratory tract, and skin; dermatitis; headache; dizziness; fatigue; incoordination; central nervous system depression; coma; and death from respiratory center paralysis. Liquid splashed in the eyes may cause irritation and damage.

Ethyl benzene is a clear, colorless, flammable liquid with an aromatic odor. It will form flammable mixtures with air at 64°F. Vapors are heavier than air with a vapor density of 3.7 (air = 1) and the liquid is lighter than water with a specific gravity of 0.86 (water = 1).

***Xylene Permissible Exposure Limit – 100 ppm***

Xylene overexposure may cause irritation of the eyes, respiratory tract, and skin; dermatitis; headache; dizziness; fatigue; incoordination; liver and kidney damage, central nervous system depression; coma; and death. Liquid splashed in the eyes may cause irritation and damage.

Xylene is a clear, colorless, flammable liquid with an aromatic odor. It will form flammable mixtures with air at 81°F. Vapors are heavier than air with a vapor density of 3.7 (air = 1) and the liquid is greater than water with a specific gravity of 0.86 (water = 1).

***Tetrachloroethene      Threshold Limit Value = NA***

Tetrachloroethene overexposure may cause irritation of the eyes, respiratory tract, and skin; headache; dermatitis; dizziness; fatigue; incoordination; central nervous system depression; liver damage, coma; and death. Liquid splashed in the eyes may cause irritation and damage.

Tetrachloroethene is a clear, colorless, non-flammable liquid with an ether-like odor. Vapors are slightly heavier than air with a vapor density of 1.08 (air = 1), and the liquid is heavier than water with a specific gravity of 1.63 (water = 1).

***Perchloroethylene      Threshold Limit Value = 25 ppm***

Perchloroethylene overexposure may cause irritation of the eyes, respiratory tract, and skin; headache; dermatitis; dizziness; fatigue; incoordination; central nervous system depression; liver damage, coma; and death. Liquid splashed in the eyes may cause irritation and damage.

Perchloroethylene is a clear, colorless, non-flammable liquid with an ether-like odor. Vapors are slightly heavier than air with a vapor density of 1.08 (air = 1), and the liquid is heavier than water with a specific gravity of 1.63 (water = 1).

***1,1,1 Trichloroethane (Methyl Chloroform) Threshold Limit Value – 1 ppm***

Liquid contact with skin or eyes causes painful irritation and dry skin. Vapors may cause irritation of the eyes, nose, and throat; dizziness; headache; slurred speech; double vision; central nervous system depression; liver damage, kidney damage; coma; and death.

Trichloroethane is a clear, colorless, non-flammable, volatile liquid with a chloroform like odor. It will burn given sufficient heat. Vapors are heavier than air with a vapor density of 4.55 (air = 1) and the liquid is heavier than water with a specific gravity of 1.33 (water = 1).

**3.2 PHYSICAL HAZARDS**

To minimize physical hazards, OHM has developed standard safety protocols which will be followed at all times. Failure to follow safety protocols will result in expulsion of an employee from the site and appropriate disciplinary actions.

The SS and SSO will observe the general work practices of each crew member and equipment operator, and enforce safe procedures to minimize physical hazards. Hard hats, safety glasses, and steel-toe safety boots are required in all areas of the site. Site-specific hazards and all necessary precautions will be discussed at the daily safety meetings. The Health and Safety Procedures Manual for LANTDIV will be maintained at the project site as a reference document.

The following sections are typical safety hazards that may occur at project site along with relevant hazard control procedures.

***Heavy and Bulky Loads***

Intelligent thought shall be exercised before heavy and bulky loads are lifted or handled manually by personnel. Mechanical equipment such as fork-lifts, wheel barrows, hand-trucks, loaders, and cranes shall be utilized when possible and needed. Note: Back injuries are real, debilitating, unproductive, and costly to both employees and employers, and sometime permanent. Back injury prevention must be given high priority on all project sites. If you think the load you are about to lift is too heavy or bulky, it probably is! Get help or utilize mechanical equipment.

***Flame, Heat or Spark Producing Operations***

Because of the possibilities of flammable materials being present at this site, flame, heat, or spark producing operations will be limited. If a case arises where hot work is necessary, OHM will follow the hot work procedures and permit detailed in the appendix.

***High Pressure Washing***

Washing or cleaning certain pieces of equipment may require the use of high pressure washers, referred to as lasers. These devices can be hazardous if not used properly. Specific laser safety instructions are provided in Procedure No. 30. The following protective equipment will be worn: safety shoes or boots, metal foot and shin guards, goggles and face shield, hard hat, heavy-duty PVC rain suit, heavy chemical resistant gloves. Only trained personnel will operate the high pressure washer. The operator must have an assistant to

move the hose and back-up the operator. Other personnel must remain a minimum of 25 feet from the area. The equipment cannot be altered. (Trigger shall never be tied down.) Operator should be changed every hour. Hydroblasting lacerations are serious and must be reported.

### ***Small Quantity Flammable Liquids***

Small quantities of flammable liquids will be stored in “safety” cans and labeled according to contents.

### ***Electrical Hazards***

Overhead power lines, downed electrical wires, and buried cables all pose a danger of shock or electrocution if workers contact or sever them during site operations. Electrical equipment used on-site may also pose a hazard to workers. To help minimize this hazard, low-voltage equipment with ground-fault interrupters and water-tight, corrosion-resistant, connecting cables will be used on-site. In addition, lightning is a hazard during outdoor operations, particularly for workers handling metal containers or equipment. To eliminate this hazard, weather conditions will be monitored and work will be suspended during electrical storms. An additional electrical hazard involves capacitors that may retain a charge. All such items will be properly grounded before handling. OSHA’s standard 29 CFR Part 1910.137 describes clothing and equipment for protection against electrical hazards.

Electrical devices and equipment must be de-energized prior to working near them. All extension cords must be kept out of water, protected from crushing, and inspected regularly to ensure structural integrity. Temporary electrical circuits must be protected with ground fault interrupters. Only qualified electricians are authorized to work on electrical circuits.

### ***Slip/Trip/Fall Hazards***

Some areas may have wet surfaces which will greatly increase the possibility of inadvertent slips. Caution must be exercised when using steps and stairs due to slippery surfaces in conjunction with fall hazards. Use of handrails when climbing stairs will be enforced, and handrails will remain secure until the support itself is removed and lowered to ground level. Good housekeeping practices are essential to minimize trip hazards. Safety belts or harnesses will be required by personnel working four feet or more above surfaces, including manlifts.

The work area shall be kept clean and orderly. Tools and debris must be picked up and placed in the proper place to prevent a tripping hazard. Walkways and grating shall be kept in good condition. Spills will be cleaned up immediately. Personnel shall not walk or climb on piping, valves, fittings, or any other equipment not designed as walking surfaces.

### ***Ground Personnel***

All ground personnel should be constantly aware of the possibility of slips, trips, and falls due to poor and possibly slippery footing in the work areas. Before crossing either in front of or behind a piece of heavy equipment, ground personnel will signal the equipment operator and receive confirmation before moving.

### ***Head and Back Injuries***

As minimum requirements, hard hats and safety glasses will be donned prior to performing any site activities. This requirement will prevent minor injuries caused by bumping one's head while working around and under piping and other process related structures. At the daily safety meeting, personnel are instructed in proper lifting techniques and reminded not to lift heavy items without assistance.

### ***Falling Objects***

OHM believes that the dismantlement process as well as other remediation processes can be accomplished without any object, regardless of size, free falling to the ground. All support structures will be slowly lowered to the ground using a grapple and/or skip bucket. No personnel shall work under this equipment at any time. Also, the SSO will ensure that an adequate area is clear of personnel while the equipment is in operation.

### ***Confined Space Entry***

A Confined Space Entry (ES) is defined as an enclosed area having a limited means of egress where ventilation is not adequate to remove a toxic or flammable atmosphere or oxygen deficiency which may exist. Examples of ESs include, but are not limited to the following: tanks, boilers, vessels, bins, manholes, tunnels, pipelines, underground utility vaults, or any open top space more than 4 feet in depth, such as pits, tubes, trenches, or vessels. Procedure No. 24 in the OHM Health and Safety Procedures Manual outlines OHM's entry procedures in detail.

The OHM Confined Space Permit will be completed before entry. The written rescue plan will include the type of equipment to be used and the names of the rescue and standby personnel. The atmosphere will be monitored for oxygen, combustible gases, and toxins. All personnel will be trained for confined space entry. The confined space will be ventilated, purged when possible and isolated. and locked out and tagged out if there are mechanical or electrical hazards.

The SS will be responsible for securing the permit. The permit will list employees performing work, monitoring the work, and will also list rescue personnel and employees conducting the pre-entry briefing. The permit will provide type of confined space preparation performed, pre-entry atmosphere testing results, emergency/rescue procedures, entry/egress requirements, other potential hazards, subcontractor notifications, and the permit authorization signature.

### ***Equipment and Hand Tools***

All hand tools and power tools shall be in good repair and will be used only for the task for which they were designed. All damaged tools will be tagged "Out of Service." All tools will be kept clean. Sharp tools shall not be carried in pockets. When working, overhead tools will be placed in a holding receptacle or secured when not in use. Tools cannot be thrown or dropped from heights. Only non-sparking tools will be used in flammable or explosive atmospheres. Cheater pipes will not be used.

### ***Ladders***

Access to high places will be obtained by using approved ladders and stairs in accordance with ANSI 14.1-3. Ladders will be used for access to and from the excavation.

## **3.3 ENVIRONMENTAL HAZARDS**

Environmental factors such as weather, wild animals, in-sects, and irritant plants pose a hazard when performing outdoor work. The SSO and SS will take all necessary measures to alleviate these hazards should they arise.

### **3.3.1 Heat Stress**

The combination of warm ambient temperature and protective clothing result in the potential for heat stress. Heat stress disorders include:

- Heat rash
- Heat cramps
- Heat exhaustion
- Heat stroke

Heat stress prevention is outlined in procedure No. 22 of the OHM Corp. Health and Safety Procedures manual. This information will be reviewed during safety meetings. Workers will be encouraged to increase consumption of water and electrolyte-containing beverages (e.g., Gatorade).

The following is a summary of the signs and symptoms of heat stress disorders.

#### ***Heat Rash***

Characteristic rash which may develop on the skin in areas which may be chapped by clothing. Frequent clothing changes help to prevent chapping from contact with wet clothes.

#### ***Heat Cramps***

Caused by heavy sweating and inadequate electrolyte replacement. Provide frequent breaks with fluid replacement. Cramps are usually relieved when victim is moved to a cool resting place and provided fluids every 15 minutes for approximately 1 hour. Symptoms include:

- Muscle spasms
- Pain in the hands, feet, abdomen

#### ***Heat Exhaustion***

Caused by increased stress of various body organs including inadequate blood circulation due to cardiovascular insufficiency or dehydration. Immediately remove the victim from the hot environment and provide rest while lying the victim down with feet elevated, and care for shock. Attempt to cool the victim by fanning or applying wet towels. Provide fluid replacement every 15 minutes and refer for medical evaluation if not improved within 30 minutes. Symptoms include:

- Pale, cool, moist skin
- Heavy sweating
- Dizziness
- Nausea
- Fainting

**Heat Stroke**

Temperature regulation fails and the body core temperature rises to critical levels. Immediate action must be taken to cool the body. Competent medical care must be obtained immediately since this is a life threatening disorder. Symptoms include:

- Hot, dry skin, usually red, mottled or cyanotic
- 104° temperature
- Confusion, dizziness
- Loss of consciousness
- Convulsions
- Strong, rapid pulse

It is recommended that workers break at least every two hours for 10 to 15 minute rest periods when temperatures rise above 72.5 degrees F and protective clothing is worn. Ambient temperatures will be determined from a Hg/glass thermometer shielded from radiant heat. In addition, workers are encouraged to take rests whenever they feel any adverse effects that may be heat-related. The frequency of breaks may need to be increased upon worker recommendation to the SSO and SS. Heat stress can be prevented by assuring an adequate work/rest schedule; guidelines are printed below.

<b>AMBIENT TEMPERATURE</b>	<b>LEVEL D PPE</b>	<b>LEVEL C PPE/ MODIFIED LEVEL D</b>
90° F or above	After 45 minutes of work	After 15 minutes of work
87.5 F-90 F	After 60 minutes of work	After 30 minutes of work
82.5-87.5 F	After 90 minutes of work	After 60 minutes of work
77.5-82.5 F	After 120 minutes of work	After 90 minutes of work
72.5-77.5 F	After 150 minutes of work	After 120 minutes of work

The work/rest schedule can be calculated based on heat stress monitoring results. Monitoring consists of taking the radial pulse of a worker for 30 seconds immediately after exiting the work area. If the heart rate exceeds 110 beats per minute at the beginning of the rest period, shorten the next work cycle by 1/3 and keep the rest period the same. If the heart rate still exceeds 110 beats per minute at the next rest period, decrease the work period by 1/3. The initial rest period should be at least 10 minutes.

Monitoring for heat stress will begin when the ambient temperature reaches or exceeds 70 degrees Fahrenheit when wearing Level C PPE, or 80 degrees Fahrenheit for site activities performed in Level D. Monitoring will include pulse rate, weight loss, oral temperature and signs and symptoms of heat stress. The employees radial pulse will be monitored for 30 seconds to determine heart rate. When monitored, oral temperatures (OT) will be obtained

utilizing a clinical thermometer or equivalent. If the employees' OT exceeds 99.6°F, the work period will be reduced by 1/3. If after this work period, the oral temperature still exceeds 99.6°F, the work period will again be shortened by 1/3. If the employee's OT exceeds 100.6°F, the employee will not be permitted to wear PPE. See Procedure 22 LANTDIV Health and Safety Procedures Manual.

### **3.3.2 Exposure to Cold**

With outdoor work in the winter months, the potential exists for hypothermia and frostbite.

Protective clothing greatly reduces the possibility of hypothermia in workers. However, personnel will be instructed to wear warm clothing and to stop work to obtain more clothing if they become too cold. Employees will also be advised to change into dry clothes if their clothing becomes wet from perspiration or from exposure to precipitation. Since wind chill temperature takes into account the potential for loss of body heat through convection, the wind-chill adjusted temperature will be used to evaluate for potential cold stress occurrence.

In cold weather, the potential for frostbite exists, especially in body extremities. Personnel will be instructed to pay particular attention to hands, feet, and any exposed skin when dressing. Personnel will be advised to obtain more clothing if they begin to experience loss of sensation due to cold exposure.

Employees will be encouraged to use the heated shelters on site at regular intervals depending upon the severity of ambient temperatures. When temperatures are less than 20°F (actual or wind chill) workers should break regularly to the heated shelter to warm up (every 45 minutes at a minimum). Since cold weather does cause significant water loss as a result of the dryness of the air, fluid intake will be encouraged to prevent dehydration which directly affects blood volumes and flow to the extremities. Warm, sweet, caffeine-free, nonalcoholic drinks and soup offer the best fluid replacement and provide calorie energy. Symptoms of cold stress, including heavy shivering, excessive fatigue, drowsiness, irritability, or euphoria necessitate immediate return to the shelter.

### **3.3.3 Project Hazard Communication**

The purpose of hazard communication (Employee Right-to-Know) is to ensure that the hazards of all chemicals located at this field project site are transmitted (communicated) according to 29 CFR 1926.59 to all OHM personnel and OHM subcontractors. OHM's Corporate Hazard Communication Program is included in Appendix B for reference. Hazard communication will include the following:

#### ***Container Labeling***

OHM personnel will ensure that all drums and containers are labeled according to contents. These drums and containers will include those from manufacturers and those produced on site by operations. All incoming and outgoing labels shall be checked for identity, hazard warning, and name and address of responsible party.



### ***Material Safety Data Sheets (MSDSs)***

There will be an MSDS located on site for each hazardous chemical known to be used on site. All MSDSs will be located in Appendix C of the SHSP. The site safety plan can be found in the project office trailer.

### ***Employee Information and Training***

Training employees on chemical hazards is accomplished through an ongoing corporate training program. Additionally, chemical hazards are communicated to employees through daily safety meetings held at OHM field projects and by an initial site orientation program.

At a minimum, OHM and related subcontractor employees will be instructed on the following:

- Chemicals and their hazards in the work area
- How to prevent exposure to these hazardous chemicals
- What the company has done to prevent workers' exposure to these chemicals
- Procedures to follow if they are exposed to these chemicals.
- How to read and interpret labels and MSDSs for hazardous substances found on OHM sites
- Emergency spill procedures
- Proper storage and labeling

Before any new hazardous chemical is introduced on site, each OHM and related subcontractor employee will be given information in the same manner as during the safety class. The site supervisor will be responsible for seeing that the MSDS on the new chemical is available for review by on site personnel. The information pertinent to the chemical hazards will be communicated to project personnel.

Morning safety meetings will be held and the hazardous materials used on site will be discussed. Attendance is mandatory for all on site employees.

Refer to Appendix C of the site safety plan to find a list of hazardous chemicals anticipated to be brought to the site and the corresponding MSDSs for these chemicals.

#### **3.3.4 Noise**

Hearing protection is required for workers operating or working near heavy equipment, where the noise level is greater than 85 dbA (Time Weighted Average) as well as personnel working around heavy equipment. The SSO will determine the need and appropriate testing procedures, (i.e., sound level meter and/or dosimeter) for noise measurement.

### **3.4 TASK-SPECIFIC RISK ASSESSMENT/ACTIVITY HAZARD ANALYSIS**

Prior to beginning each major phase of work, an activity hazard analysis (form included in Appendix E) will be performed. The analysis will define the activity being performed, identify the sequence of work, the specific hazards anticipated and the control measures to be implemented to eliminate or reduce each hazard to an acceptable level.

Work will not proceed on that project phase until the activity hazard analysis has been accepted by the designated on-site authority, as well as being discussed with all site personnel that will perform the activity. The following Task-Specific Risk Assessment/Activity Hazard Analysis identifies the major project phases and anticipated hazards to be encountered and control measures that will be instituted during the execution of the scope of work, previously approved by LANTDIV for this project.

### Task 1: Mobilization and Site Preparation

Task Breakdown	Potential Hazards	Hazard Control Measures
Mobilization and Site Preparation Subtasks: Equipment mobilization Installation facilities Utility connections	Struck by, Against Heavy Equipment, Flying Debris, Protruding Objects	<ul style="list-style-type: none"> <li>• Use reflective warning vests when exposed to vehicular traffic</li> <li>• Isolate equipment swing areas</li> <li>• Make eye contact with operators before approaching equipment</li> <li>• Restrict entry to the work area to authorized personnel</li> <li>• Wear hard hats, safety glasses with side shields, or splash/face shields and goggles, and steel-toe safety boots at all times</li> <li>• Understand and review posted hand signals</li> </ul>
	Handling Heavy Objects	<ul style="list-style-type: none"> <li>• Observe proper lifting techniques</li> <li>• Obey sensible lifting limits (60 pounds maximum per person manual lifting)</li> <li>• Use mechanical lifting equipment (hand carts, trucks) to move large awkward loads</li> <li>• Do not exceed equipment/crane load specifications when hoisting loads</li> <li>• Do not suspend loads over ground personnel</li> </ul>
	Electrical Shock	<ul style="list-style-type: none"> <li>• De-energize or shut off utility lines at their source before work begins</li> <li>• Use double insulated or properly grounded electric power-operated tools</li> <li>• Provide an equipment-grounding conductor program or employ ground-fault circuit interrupters</li> <li>• Use qualified electricians to hook up electrical circuits</li> <li>• Inspect all extension cords daily for structural integrity, ground continuity, and damaged insulation</li> <li>• Cover or elevate electric wire or flexible cord passing through work areas to protect from damage</li> <li>• Keep all plugs, cords, and receptacles out of water</li> <li>• Use approved water-proof, weather-proof type if exposure is likely</li> <li>• Inspect all electrical power circuits prior to commencing work</li> <li>• Follow Lockout/Tagout procedures in accordance with OHM Health and Safety Procedures Manual</li> </ul>
	Slips, Trips, Falls	<ul style="list-style-type: none"> <li>• Clear walkways of equipment, construction debris and other materials</li> <li>• Mark, identify or barricade other obstructions</li> <li>• Use body harness and lifeline when working 10 feet or more above the ground</li> <li>• Use approved ladders in accordance with OHM Health and Safety Procedures Manual</li> </ul>
	Inhalation and Contact with Hazardous Substances	<ul style="list-style-type: none"> <li>• Provide workers proper skin, eye and respiratory protection based on the exposure hazards present</li> <li>• Review hazardous properties of site contaminants with workers before operations begin</li> <li>• Wear specified level of protection when entering building to identify salvageable materials</li> </ul>
	Fire/Explosion	<ul style="list-style-type: none"> <li>• Eliminate sources of ignition from the work area</li> <li>• Prohibit smoking</li> <li>• Provide ABC (or equivalent) fire extinguishers in all work areas, flammable storage areas, generator and compressor facilities</li> <li>• Store flammable liquids in well ventilated areas</li> <li>• Post "NO SMOKING" signs</li> <li>• Store combustible materials away from flammables</li> <li>• Store all compressed gas cylinders upright, caps in place when not in use</li> <li>• Separate Flammables and Oxidizers by 20 feet</li> </ul>
	Contact Dermatitis	<ul style="list-style-type: none"> <li>• Wear PPE to avoid skin contact with contaminated surfaces or other skin irritants when installing testing/water treatment system or handling treatment chemicals</li> </ul>

**Task 2: Drill and install extraction wells and well vaults**

Task Breakdown	Potential Hazards	Hazard Control Measures
Drill and install extraction wells and well vaults	Struck by, Against Heavy Equipment, Flying Debris, Protruding Objects	<ul style="list-style-type: none"> <li>• Restrict entry to the work area to authorized personnel</li> <li>• Wear hard hats, safety glasses with side shields, or splash/face shields and goggles, and steel-toe safety boots at all times</li> </ul>
	Handling Heavy Objects	<ul style="list-style-type: none"> <li>• Observe proper lifting techniques</li> <li>• Obey sensible lifting limits (60 pounds maximum per person manual lifting)</li> <li>• Use mechanical lifting equipment (hand carts, trucks) to move large awkward loads</li> </ul>
	Slips, Trips, Falls	<ul style="list-style-type: none"> <li>• Clear walkways of equipment, construction debris and other materials</li> <li>• Mark, identify or barricade other obstructions</li> <li>• Use body harness and lifeline when working 6 feet or more above the ground</li> <li>• Use approved ladders in accordance with OHM Health and Safety Procedures Manual</li> </ul>
	Inhalation and contact with hazardous substances	<ul style="list-style-type: none"> <li>• Provide workers proper skin, eye and respiratory protection based on the exposure hazards present</li> <li>• Review hazardous properties of site contaminants with workers before operations begin</li> <li>• Wear splash shield and saran coveralls when soaking, handling wet materials, pressure washing</li> </ul>
	Fire/Explosion	<ul style="list-style-type: none"> <li>• Eliminate sources of ignition from the work area</li> <li>• Prohibit smoking</li> <li>• Provide ABC (or equivalent) fire extinguishers in all work areas, flammable storage areas, generator and compressor facilities</li> <li>• Store flammable liquids in well ventilated areas</li> <li>• Post "NO SMOKING" signs</li> <li>• Store combustible materials away from flammables</li> <li>• Store all compressed gas cylinders upright, caps in place when not in use</li> <li>• Separate flammables and oxidizers by 20 feet.</li> </ul>
	Rotating Equipment	<ul style="list-style-type: none"> <li>• Stay clear of rotating equipment</li> <li>• Wear close fitting clothes</li> <li>• Place four guide wires on drilling rig</li> <li>• Place cowl on drill string to prevent airborne dust</li> <li>• Use wetting agents for dust suppression</li> </ul>
	Buried and Overhead Electrical Utility Hazards	<ul style="list-style-type: none"> <li>• Maintain 15-foot buffer between heavy equipment and overhead electrical utilities</li> <li>• Locate all buried utilities prior to drilling</li> </ul>
	Noise	<ul style="list-style-type: none"> <li>• Personnel will wear hearing protection above 85 dBa</li> <li>• Personnel will be included in a hearing conservation program</li> </ul>

### Task 3: Well Abandonment

Task Breakdown	Potential Hazards	Hazard Control Measures
Well abandonment	Struck by, Against Heavy Equipment, Flying Debris, Protruding Objects	<ul style="list-style-type: none"> <li>• Restrict entry to the work area to authorized personnel</li> <li>• Wear hard hats, safety glasses with side shields, or splash/face shields and goggles, and steel-toe safety boots at all times</li> </ul>
	Handling Heavy Objects	<ul style="list-style-type: none"> <li>• Observe proper lifting techniques</li> <li>• Obey sensible lifting limits (60 pounds maximum per person manual lifting)</li> <li>• Use mechanical lifting equipment (hand carts, trucks) to move large awkward loads</li> </ul>
	Slips, Trips, Falls	<ul style="list-style-type: none"> <li>• Clear walkways of equipment, construction debris and other materials</li> <li>• Mark, identify or barricade other obstructions</li> <li>• Use body harness and lifeline when working 6 feet or more above the ground</li> <li>• Use approved ladders in accordance with OHM Health and Safety Procedures Manual</li> </ul>
	Inhalation and contact with hazardous substances	<ul style="list-style-type: none"> <li>• Provide workers proper skin, eye and respiratory protection based on the exposure hazards present</li> <li>• Review hazardous properties of site contaminants with workers before operations begin</li> <li>• Wear splash shield and saran coveralls when soaking, handling wet materials, pressure washing</li> </ul>

#### Task 4: Well Development

Task Breakdown	Potential Hazards	Hazard Control Measures
Well development	Slips, Trips, Falls	<ul style="list-style-type: none"><li>• Clear walkways of equipment, construction debris and other materials</li><li>• Mark, identify or barricade other obstructions</li><li>• Use body harness and lifeline when working 10 feet or more above the ground</li><li>• Use approved ladders in accordance with OHM Health and Safety Procedures Manual</li></ul>
	Inhalation and Contact with Hazardous Substances	<ul style="list-style-type: none"><li>• Provide workers proper skin, eye and respiratory protection based on the exposure hazards present</li><li>• Review hazardous properties of site contaminants with workers before operations begin</li><li>• Wear splash protection when sampling liquids, sludges</li></ul>
	Contact Dermatitis	<ul style="list-style-type: none"><li>• Wear PPE to avoid skin contact with contaminated surfaces or other skin irritants when sampling water treatment influent, effluent, or treatment chemicals</li></ul>

**Task 5: Jack and Bone Installation**

Task Breakdown	Potential Hazards	Hazard Control Measures
Jack and bore installation	Struck by, Against Heavy Equipment, Flying Debris, Protruding Objects	<ul style="list-style-type: none"> <li>• Restrict entry to the work area to authorized personnel</li> <li>• Wear hard hats, safety glasses with side shields, or splash/face shields and goggles, and steel-toe safety boots at all times</li> </ul>
	Handling Heavy Objects	<ul style="list-style-type: none"> <li>• Observe proper lifting techniques</li> <li>• Obey sensible lifting limits (60 pounds maximum per person manual lifting)</li> <li>• Use mechanical lifting equipment (hand carts, trucks) to move large awkward loads</li> </ul>
	Slips, Trips, Falls	<ul style="list-style-type: none"> <li>• Clear walkways of equipment, construction debris and other materials</li> <li>• Mark, identify or barricade other obstructions</li> <li>• Use body harness and lifeline when working 6 feet or more above the ground</li> <li>• Use approved ladders in accordance with OHM Health and Safety Procedures Manual</li> </ul>
	Excavation Care-in	<ul style="list-style-type: none"> <li>• All underground installations will be located and marked</li> <li>• All materials must be kept 2 feet from the excavation edge</li> <li>• Daily inspections of the excavations will be conducted by a competent person and soil type determined</li> <li>• The OHM excavation permit will be used</li> <li>• Excavations for piping trenches and others requiring personnel entry will not be greater than 4 feet deep</li> <li>• Excavations with potential hazardous atmosphere must be tested O<sub>2</sub>/LEL/toxic</li> <li>• Follow OHM SOP for excavation</li> </ul>
	Rotating Equipment	<ul style="list-style-type: none"> <li>• Stay clear of rotating equipment</li> <li>• Wear close fitting clothes</li> <li>• Place four guide wires on drilling rig</li> <li>• Place cowl on drill string to prevent airborne dust</li> <li>• Use wetting agents for dust suppression</li> </ul>
	Buried and Overhead Electrical Utility Hazards	<ul style="list-style-type: none"> <li>• Maintain 15-foot buffer between heavy equipment and overhead electrical utilities</li> <li>• Locate all buried utilities prior to drilling</li> </ul>
	Noise	<ul style="list-style-type: none"> <li>• Personnel will wear hearing protection above 85 dBa</li> <li>• Personnel will be included in a hearing conservation program</li> </ul>

**Task 6: Trench and Install Piping/Well Load for System**

Task Breakdown	Potential Hazards	Hazard Control Measures
Trench and install piping/well head for system	Struck by, Against Heavy Equipment, Flying Debris, Protruding Objects	<ul style="list-style-type: none"> <li>• Restrict entry to the work area to authorized personnel</li> <li>• Wear hard hats, safety glasses with side shields, or splash/face shields and goggles, and steel-toe safety boots at all times</li> </ul>
	Handling Heavy Objects	<ul style="list-style-type: none"> <li>• Observe proper lifting techniques</li> <li>• Obey sensible lifting limits (60 pounds maximum per person manual lifting)</li> <li>• Use mechanical lifting equipment (hand carts, trucks) to move large awkward loads</li> </ul>
	Slips, Trips, Falls	<ul style="list-style-type: none"> <li>• Clear walkways of equipment, construction debris and other materials</li> <li>• Mark, identify or barricade other obstructions</li> <li>• Use body harness and lifeline when working 6 feet or more above the ground</li> <li>• Use approved ladders in accordance with OHM Health and Safety Procedures Manual</li> </ul>
	Inhalation and contact with hazardous substances	<ul style="list-style-type: none"> <li>• Provide workers proper skin, eye and respiratory protection based on the exposure hazards present</li> <li>• Review hazardous properties of site contaminants with workers before operations begin</li> <li>• Wear specified level of protection</li> </ul>
	Fire/Explosion	<ul style="list-style-type: none"> <li>• Eliminate sources of ignition from the work area</li> <li>• Prohibit smoking</li> <li>• Provide ABC (or equivalent) fire extinguishers in all work areas, flammable storage areas, generator and compressor facilities</li> <li>• Store flammable liquids in well ventilated areas</li> <li>• Post "NO SMOKING" signs</li> <li>• Store combustible materials away from flammables</li> <li>• Store all compressed gas cylinders upright, caps in place when not in use</li> <li>• Separate Flammables and Oxidizers by 20 feet</li> </ul>
	Excavation Care-in	<ul style="list-style-type: none"> <li>• All underground installations will be located and marked</li> <li>• All materials must be kept 2 feet from the excavation edge</li> <li>• Daily inspections of the excavations will be conducted by a competent person and soil type determined</li> <li>• The OHM excavation permit will be used</li> <li>• Excavations for piping trenches and others requiring personnel entry will not be greater than 4 feet deep</li> <li>• Excavations with potential hazardous atmosphere must be tested O<sub>2</sub>/LEL/toxic</li> <li>• Follow OHM SOP for excavation</li> </ul>
	Utility (electric/gas)	<ul style="list-style-type: none"> <li>• Locate all buried utilities prior to excavation operations</li> <li>• Maintain 15-foot buffer between heavy equipment and overhead electrical utilities</li> </ul>



### Task 7: Installation of Power, Control and Associated Electrical Equipment

Task Breakdown	Potential Hazards	Hazard Control Measures
Installation of power control, associated electrical equipment for system	Struck by, Against Heavy Equipment, Flying Debris, Protruding Objects	<ul style="list-style-type: none"> <li>• Restrict entry to the work area to authorized personnel</li> <li>• Wear hard hats, safety glasses with side shields, or splash/ face shields and goggles, and steel-toe safety boots at all times</li> </ul>
	Handling Heavy Objects	<ul style="list-style-type: none"> <li>• Observe proper lifting techniques</li> <li>• Obey sensible lifting limits (60 pounds maximum per person manual lifting)</li> <li>• Use mechanical lifting equipment (hand carts, trucks) to move large awkward loads</li> </ul>
	Fire/Explosion	<ul style="list-style-type: none"> <li>• Eliminate sources of ignition from the work area</li> <li>• Prohibit smoking</li> <li>• Provide ABC (or equivalent) fire extinguishers in all work areas, flammable storage areas, generator and compressor facilities</li> <li>• Store flammable liquids in well ventilated areas</li> <li>• Post "NO SMOKING" signs</li> <li>• Store combustible materials away from flammables</li> <li>• Store all compressed gas cylinders upright, caps in place when not in use</li> <li>• Separate flammables and oxidizers by 20 feet.</li> </ul>
	Slips, Trips, Falls	<ul style="list-style-type: none"> <li>• Clear walkways of equipment, construction debris and other materials</li> <li>• Mark, identify or barricade other obstructions</li> <li>• Use body harness and lifeline when working 6 feet or more above the ground</li> <li>• Use approved ladders in accordance with OHM Health and Safety Procedures Manual</li> </ul>
	Inhalation and contact with hazardous substances	<ul style="list-style-type: none"> <li>• Provide workers proper skin, eye and respiratory protection based on the exposure hazards present</li> <li>• Review hazardous properties of site contaminants with workers before operations begin</li> <li>• Wear specified level of protection</li> </ul>

### Task 8: Equipment Installation and Plumbing for System

Task Breakdown	Potential Hazards	Hazard Control Measures
Equipment Installation and Plumbing for System	Struck by, Against Heavy Equipment, Flying Debris, Protruding Objects	<ul style="list-style-type: none"> <li>• Restrict entry to the work area to authorized personnel</li> <li>• Wear hard hats, safety glasses with side shields, or splash/face shields and goggles, and steel-toe safety boots at all times</li> </ul>
	Handling Heavy Objects	<ul style="list-style-type: none"> <li>• Observe proper lifting techniques</li> <li>• Obey sensible lifting limits (60 pounds maximum per person manual lifting)</li> <li>• Use mechanical lifting equipment (hand carts, trucks) to move large awkward loads</li> </ul>
	Electrical Shock	<ul style="list-style-type: none"> <li>• De-energize or shut off utility lines at their source before work begins</li> <li>• Use double insulated or properly grounded electric power-operated tools</li> <li>• Provide an equipment-grounding conductor program or employ ground-fault circuit interrupters</li> <li>• Use qualified electricians to hook up electrical circuits</li> <li>• Inspect all extension cords daily for structural integrity, ground continuity, and damaged insulation</li> <li>• Cover or elevate electric wire or flexible cord passing through work areas to protect from damage</li> <li>• Keep all plugs, cords, and receptacles out of water</li> <li>• Use approved water-proof, weather-proof type if exposure is likely</li> <li>• Inspect all electrical power circuits prior to commencing work</li> <li>• Follow Lockout/Tagout procedures in accordance with OHM Health and Safety Procedures Manual</li> </ul>
	Slips, Trips, Falls	<ul style="list-style-type: none"> <li>• Clear walkways of equipment, construction debris and other materials</li> <li>• Mark, identify or barricade other obstructions</li> <li>• Use body harness and lifeline when working 6 feet or more above the ground</li> <li>• Use approved ladders in accordance with OHM Health and Safety Procedures Manual</li> </ul>
	Crane Operation	<ul style="list-style-type: none"> <li>• Prepare lift plan</li> <li>• Inspect all rigging prior to use</li> <li>• Load limits on crane, hooks, hoist, sling, wire rope cannot be exceeded</li> </ul>

### Task 9: System Start Up and Testing

Task Breakdown	Potential Hazards	Hazard Control Measures
System Start-up and Testing	Struck by, Against Heavy Equipment, Flying Debris, Protruding Objects	<ul style="list-style-type: none"> <li>Restrict entry to the work area to authorized personnel</li> <li>Wear hard hats, safety glasses with side shields, or splash/face shields and goggles, and steel-toe safety boots at all times</li> </ul>
	Handling Heavy Objects	<ul style="list-style-type: none"> <li>Observe proper lifting techniques</li> <li>Obey sensible lifting limits (60 pounds maximum per person manual lifting)</li> <li>Use mechanical lifting equipment (hand carts, trucks) to move large awkward loads</li> </ul>
	Electrical Shock	<ul style="list-style-type: none"> <li>De-energize or shut off utility lines at their source before work begins</li> <li>Electrical circuits must be tested and proved to be de-energized before work begins</li> <li>Use double insulated or properly grounded electric power-operated tools</li> <li>Provide an equipment-grounding conductor program or employ ground-fault circuit interrupters</li> <li>Use qualified electricians to hook up electrical circuits</li> <li>Inspect all extension cords daily for structural integrity, ground continuity, and damaged insulation</li> <li>Cover or elevate electric wire or flexible cord passing through work areas to protect from damage</li> <li>Keep all plugs, cords, and receptacles out of water</li> <li>Use approved water-proof, weather-proof type if exposure is likely</li> <li>Inspect all electrical power circuits prior to commencing work</li> <li>Follow Lockout/Tagout procedures in accordance with OHM Health and Safety Procedures Manual</li> </ul>
	Slips, Trips, Falls	<ul style="list-style-type: none"> <li>Clear walkways of equipment, construction debris and other materials</li> <li>Mark, identify or barricade other obstructions</li> <li>Use body harness and lifeline when working 6 feet or more above the ground</li> <li>Use approved ladders in accordance with OHM Health and Safety Procedures Manual</li> </ul>
	Inhalation and contact with hazardous substances	<ul style="list-style-type: none"> <li>Provide workers proper skin, eye and respiratory protection based on the exposure hazards present</li> <li>Review hazardous properties of site contaminants with workers before operations begin</li> <li>Wear specified level of protection</li> </ul>
	Fire/Explosion	<ul style="list-style-type: none"> <li>Eliminate sources of ignition from the work area</li> <li>Prohibit smoking</li> <li>Provide ABC (or equivalent) fire extinguishers in all work areas, flammable storage areas, generator and compressor facilities</li> <li>Store flammable liquids in well ventilated areas</li> <li>Post "NO SMOKING" signs</li> <li>Store combustible materials away from flammables</li> <li>Store all compressed gas cylinders upright, caps in place when not in use</li> <li>Separate Flammables and Oxidizers by 20 feet</li> </ul>
	Contact Dermatitis	<ul style="list-style-type: none"> <li>Wear PPE to avoid skin contact with contaminated surfaces</li> </ul>
	Pumping equipment operation	<ul style="list-style-type: none"> <li>Inspect hoses and pumping equipment before use</li> <li>Do not leave pumps and pressurized hoses unattended while operating</li> <li>Use double diaphragm pumps for flammable liquids</li> <li>Ensure proper grounding and bonding of equipment</li> </ul>
	Spills/Splash	<ul style="list-style-type: none"> <li>Wear splash protection</li> <li>Clean up spills immediately</li> </ul>

### Task 10: System Operation and Maintenance

Task Breakdown	Potential Hazards	Hazard Control Measures
System Operation and Maintenance	Struck by, Against Heavy Equipment, Flying Debris, Protruding Objects	<ul style="list-style-type: none"> <li>Restrict entry to the work area to authorized personnel</li> <li>Wear hard hats, safety glasses with side shields, or splash/face shields and goggles, and steel-toe safety boots at all times</li> </ul>
	Handling Heavy Objects	<ul style="list-style-type: none"> <li>Observe proper lifting techniques</li> <li>Obey sensible lifting limits (60 pounds maximum per person manual lifting)</li> <li>Use mechanical lifting equipment (hand carts, trucks) to move large awkward loads</li> </ul>
	Electrical Shock	<ul style="list-style-type: none"> <li>De-energize or shut off utility lines at their source before work begins</li> <li>Electrical circuits must be tested and proved to be de-energized before work begins</li> <li>Use double insulated or properly grounded electric power-operated tools</li> <li>Provide an equipment-grounding conductor program or employ ground-fault circuit interrupters</li> <li>Use qualified electricians to hook up electrical circuits</li> <li>Inspect all extension cords daily for structural integrity, ground continuity, and damaged insulation</li> <li>Cover or elevate electric wire or flexible cord passing through work areas to protect from damage</li> <li>Keep all plugs, cords, and receptacles out of water</li> <li>Use approved water-proof, weather-proof type if exposure is likely</li> <li>Inspect all electrical power circuits prior to commencing work</li> <li>Follow Lockout/Tagout procedures in accordance with OHM Health and Safety Procedures Manual</li> </ul>
	Slips, Trips, Falls	<ul style="list-style-type: none"> <li>Clear walkways of equipment, construction debris and other materials</li> <li>Mark, identify or barricade other obstructions</li> <li>Use body harness and lifeline when working 6 feet or more above the ground</li> <li>Use approved ladders in accordance with OHM Health and Safety Procedures Manual</li> </ul>
	Inhalation and contact with hazardous substances	<ul style="list-style-type: none"> <li>Provide workers proper skin, eye and respiratory protection based on the exposure hazards present</li> <li>Review hazardous properties of site contaminants with workers before operations begin</li> <li>Wear specified level of protection</li> </ul>
	Fire/Explosion	<ul style="list-style-type: none"> <li>Eliminate sources of ignition from the work area</li> <li>Prohibit smoking</li> <li>Provide ABC (or equivalent) fire extinguishers in all work areas, flammable storage areas, generator and compressor facilities</li> <li>Store flammable liquids in well ventilated areas</li> <li>Post "NO SMOKING" signs</li> <li>Store combustible materials away from flammables</li> <li>Store all compressed gas cylinders upright, caps in place when not in use</li> <li>Separate Flammables and Oxidizers by 20 feet</li> </ul>
	Contact Dermatitis	<ul style="list-style-type: none"> <li>Wear PPE to avoid skin contact with contaminated surfaces</li> </ul>
	Pumping equipment operation	<ul style="list-style-type: none"> <li>Inspect hoses and pumping equipment before use</li> <li>Do not leave pumps and pressurized hoses unattended while operating</li> <li>Use double diaphragm pumps for flammable liquids</li> <li>Ensure proper grounding and bonding of equipment</li> </ul>
	Spills/Splash	<ul style="list-style-type: none"> <li>Wear splash protection</li> <li>Clean up spills immediately</li> </ul>
	Confined Space Entry	<ul style="list-style-type: none"> <li>Prepare confined space permit</li> <li>Monitor for combustible gas, oxygen and organic vapors</li> <li>Use only personnel trained in confined space entry</li> <li>Confined space will be isolated, locked out/tagged out if there are mechanical, electrical or engulfment hazards</li> </ul>

**Task 11: Collect Liquid Samples**

Task Breakdown	Potential Hazards	Hazard Control Measures
Collect liquid samples	Slips, Trips, Falls	<ul style="list-style-type: none"> <li>• Clear walkways of equipment, construction debris and other materials</li> <li>• Mark, identify or barricade other obstructions</li> <li>• Use body harness and lifeline when working 10 feet or more above the ground</li> <li>• Use approved ladders in accordance with OHM Health and Safety Procedures Manual</li> </ul>
	Inhalation and Contact with Hazardous Substances	<ul style="list-style-type: none"> <li>• Provide workers proper skin, eye and respiratory protection based on the exposure hazards present</li> <li>• Review hazardous properties of site contaminants with workers before operations begin</li> <li>• Wear splash protection when sampling liquids, sludges</li> </ul>
	Contact Dermatitis	<ul style="list-style-type: none"> <li>• Wear PPE to avoid skin contact with contaminated surfaces or other skin irritants when sampling water treatment influent, effluent, or treatment chemicals</li> </ul>

### Task 12: Decontaminate Equipment

Task Breakdown	Potential Hazards	Hazard Control Measures
Equipment Decontamination	Struck by, Against Heavy Equipment, Flying Debris, Protruding Objects	<ul style="list-style-type: none"> <li>• Use reflective warning vests when exposed to vehicular traffic</li> <li>• Isolate equipment swing areas</li> <li>• Make eye contact with operators before approaching equipment</li> <li>• Barricade or enclose the work area</li> <li>• Restrict entry to the work area to authorized personnel</li> <li>• Wear hard hats, safety glasses with side shields, or splash/face shields and goggles, and steel-toe safety boots at all times</li> </ul>
	Sharp Objects	<ul style="list-style-type: none"> <li>• Wear cut resistant work gloves when the possibility of lacerations or other injury may be caused by sharp edges or objects</li> </ul>
	High Noise Levels	<ul style="list-style-type: none"> <li>• Use hearing protection when exposed to excessive noise levels (greater than 85 dBA over an 8-hour work period)</li> </ul>
	Handling Heavy Objects	<ul style="list-style-type: none"> <li>• Observe proper lifting techniques</li> <li>• Obey sensible lifting limits (60 pounds maximum per person manual lifting)</li> <li>• Use mechanical lifting equipment (hand carts, trucks) to move large awkward loads</li> <li>• Do not exceed equipment load specifications</li> <li>• Do not suspend loads over ground personnel</li> <li>• Ground personnel near cleaning vats wear splash shield and apron</li> </ul>
	Slips, Trips, Falls	<ul style="list-style-type: none"> <li>• Clear walkways of equipment, construction debris and other materials</li> <li>• Mark, identify or barricade other obstructions</li> <li>• Use body harness and lifeline when working 10 feet or more above the ground</li> <li>• Use approved ladders in accordance with OHM Health and Safety Procedures Manual</li> </ul>
	Inhalation and Contact with Hazardous Substances	<ul style="list-style-type: none"> <li>• Provide workers proper skin, eye and respiratory protection based on the exposure hazards present</li> <li>• Review hazardous properties of site contaminants with workers before operations begin</li> <li>• Wear splash shield and saran coveralls when soaking, handling wet materials, pressure washing</li> <li>• Collect and contain spent wash water for proper disposal</li> </ul>
	Burns	<ul style="list-style-type: none"> <li>• Use proper gloves, face shield/safety goggles, shin and toe guards, and splash suits to protect workers from skin burns and injury when operating hot water/steam laser (high pressure washers)</li> </ul>

**Task 13: Demobilization**

Task Breakdown	Potential Hazards	Hazard Control Measures
Demobilization	Struck by, Against Heavy Equipment, Flying Debris, Protruding Objects	<ul style="list-style-type: none"> <li>• Use reflective warning vests when exposed to vehicular traffic</li> <li>• Isolate equipment swing areas</li> <li>• Make eye contact with operators before approaching equipment</li> <li>• Restrict entry to the work area to authorized personnel</li> <li>• Wear hard hats, safety glasses with side shields, or splash/face shields and goggles, and steel-toe safety boots at all times</li> </ul>
	Handling Heavy Objects	<ul style="list-style-type: none"> <li>• Observe proper lifting techniques</li> <li>• Obey sensible lifting limits (60 pounds maximum per person manual lifting)</li> <li>• Use mechanical lifting equipment (hand carts, trucks) to move large awkward loads</li> <li>• Do not exceed equipment/crane load specifications when hoisting loads</li> <li>• Do not suspend loads over ground personnel</li> </ul>
	Electrical Shock	<ul style="list-style-type: none"> <li>• De-energize or shut off utility lines at their source before work begins</li> <li>• Use double insulated or properly grounded electric power-operated tools</li> <li>• Provide an equipment-grounding conductor program or employ ground-fault circuit interrupters</li> <li>• Use qualified electricians to hook up electrical circuits</li> <li>• Inspect all extension cords daily for structural integrity, ground continuity, and damaged insulation</li> <li>• Cover or elevate electric wire or flexible cord passing through work areas to protect from damage</li> <li>• Keep all plugs, cords, and receptacles out of water</li> <li>• Use approved water-proof, weather-proof type if exposure is likely</li> <li>• Inspect all electrical power circuits prior to commencing work</li> <li>• Follow Lockout/Tagout procedures in accordance with OHM Health and Safety Procedures Manual</li> </ul>
	Slips, Trips, Falls	<ul style="list-style-type: none"> <li>• Clear walkways of equipment, construction debris and other materials</li> <li>• Mark, identify or barricade other obstructions</li> <li>• Use body harness and lifeline when working 10 feet or more above the ground</li> <li>• Use approved ladders in accordance with OHM Health and Safety Procedures Manual</li> </ul>
	Inhalation and Contact with Hazardous Substances	<ul style="list-style-type: none"> <li>• Provide workers proper skin, eye and respiratory protection based on the exposure hazards present</li> <li>• Review hazardous properties of site contaminants with workers before operations begin</li> <li>• Wear specified level of protection when entering building to identify salvageable materials</li> </ul>
	Fire/Explosion	<ul style="list-style-type: none"> <li>• Eliminate sources of ignition from the work area</li> <li>• Prohibit smoking</li> <li>• Provide ABC (or equivalent) fire extinguishers in all work areas, flammable storage areas, generator and compressor facilities</li> <li>• Store flammable liquids in well ventilated areas</li> <li>• Post "NO SMOKING" signs</li> <li>• Store combustible materials away from flammables</li> <li>• Store all compressed gas cylinders upright, caps in place when not in use</li> <li>• Separate Flammables and Oxidizers by 20 feet</li> </ul>
	Contact Dermatitis	<ul style="list-style-type: none"> <li>• Wear PPE to avoid skin contact with contaminated surfaces or other skin irritants when dismantling testing, water treatment system or handling treatment chemicals</li> </ul>

## **4.0 WORK AND SUPPORT AREAS**

---

To prevent migration of contamination caused through tracking by personnel or equipment, work areas and personal p-protective equipment will be clearly specified prior to beginning operations. OHM has designated work areas or zones as suggested by the NIOSH/OSHA/USCG/EPA'S document titled, "Occupational Safety and Health Guidance Manual for Hazardous Waste Site Activities." Each work area will be divided into three zones as follows:

- An Exclusion or "hot" Zone (EZ)
- A Contamination Reduction Zone (CRZ)
- A Support Zone (SZ)

### **4.1 EXCLUSION ZONE**

The EZ is the area suspected of contamination and presents the greatest potential for worker exposure. Personnel entering the area must wear the mandated level of protection for that area. In certain instances, different levels of protection will be required depending on the tasks and monitoring performed within that zone.

### **4.2 CONTAMINATION REDUCTION ZONE**

The CRZ or transition zone will be established between the EZ and SZ. In this area, personnel will begin the sequential decontamination process required to exit the EZ. To prevent off-site migration of contamination and for personnel accountability, all personnel will enter and exit the EZ through the CRZ.

### **4.3 SUPPORT ZONE**

The SZ serves as a clean, control area. Operational support facilities are located within the SZ. Normal work clothing and support equipment are appropriate in this zone. Contaminated equipment or clothing will not be allowed in the SZ. The support facilities should be located upwind of site activities. There will be a clearly marked controlled access point from the SZ into the CRZ and EZ that is monitored closely by the SSO and the SS to ensure proper safety protocols are followed.

### **4.4 SITE CONTROL LOG**

A log of all personnel visiting, entering or working on the site shall be maintained in the main office trailer location. The log will record the date, name, company or agency, and time entering or exiting the site.

No visitor will be allowed in the EZ without showing proof of training and medical certification. Visitors will supply their own boots and respiratory equipment, if required. Visitors will attend a site orientation given by the SSO and sign the HASP.



## 4.5 GENERAL

The following items are requirements to protect the health and safety of workers and will be discussed in the safety briefing prior to initiating work on the site.

- Eating, drinking, chewing gum or tobacco, smoking, or any practice that increases the probability of hand to mouth transfer and ingestion of contamination is prohibited in the EZ and CRZs.
- All personnel exiting the exclusion zone or the contamination reduction zone, must at a minimum, thoroughly wash their face and hands.
- A buddy system will be used. Hand signals will be established to maintain communication.
- During site operations, each worker will consider himself as a safety backup to his partner. Off-site personnel provide emergency assistance. All personnel will be aware of dangerous situations that may develop.
- Visual contact will be maintained between buddies on site when performing hazardous duties.
- No personnel will be admitted to the site without the proper safety equipment, training, and medical surveillance certification.
- All personnel must comply with established safety procedures. Any staff member who does not comply with safety policy, as established by the SSO or the SS, will be immediately dismissed from the site.
- Proper decontamination procedures must be followed before leaving the site.
- All employees and visitors must sign in and out of the site.

## **5.0 PROTECTIVE EQUIPMENT**

---

This section addresses the various levels of personal protective equipment (PPE) which are or may be required at this job site. OHM personnel are trained in the use of all PPE utilized.

### **5.1 ANTICIPATED PROTECTION LEVELS**

<b>Task</b>	<b>Protection Level</b>
1) Mobilization and site preparation	Level D
2) Drill and install wells/vaults	Level Modified D/Level C with tyvek
3) Well abandonment	Level Modified D with tyvek, goggles
4) Well development	Level Modified D with tyvek, goggles and faceshield/Level C
5) Jack and bore installation	Level D
6) Trenching and install piping/well head	Level D clean soil Modified D/Level C contaminated soil
7) Installation of power, control and associated-electrical equipment	Level D
8) Equipment installation and plumbing	Level D
9) System startup and testing	Modified Level D with tyvek, with goggles
10) System operation and maintenance	Modified D with tyvek Level B confined space entry
11) Collect liquid samples	Modified Level D with tyvek and face shield and goggles
12) Equipment decontamination	Modified Level D with full face shield and saran
13) Demobilization	Level D

Hearing protection will be required for all personnel whenever the noise level is above 85 dBa.

### **5.2 PROTECTION LEVEL DESCRIPTIONS**

This sections lists the minimum requirements for each protection level. Modification to these requirements will be noted above.

#### **5.2.1 Level D**

Level D consists of the following:

- Safety glasses with side shields
- Hard hat
- Steel-toed work boots
- Work clothing as prescribed by weather

### **5.2.2 Modified Level D**

Modified Level D consists of the following:

- Safety glasses with side shields
- Hard hat
- Steel-toed work boots
- Nitrile, neoprene, latex or PVC overboots
- Outer nitrile, neoprene, or PVC gloves over latex sample gloves
- Face shield (when projectiles or splashes pose a hazard)
- Tyvek coverall [Polyethylene-coated Tyveks required when workers have a potential to be exposed to contaminated liquids or sludges.]

### **5.2.3 Level C**

Level C consists of the following:

- Full-face, air-purifying respirator with appropriate cartridges
- Hooded Tyvek Coveralls [Polyethylene- or saran-coated Tyveks required when workers have a potential to be exposed to contaminated liquids or sludges].
- Hard hat
- Steel-toed work boots
- Nitrile, neoprene, latex or PVC overboots
- Nitrile, neoprene, or PVC gloves over latex sample gloves
- Face shield (when projectiles or splashes pose a hazard)

### **5.2.4 Level B**

Level B protection consists of the items required for Level C protection with the exception that an air-supplied respirator is used in place of the air-purifying respirator.

### **5.2.5 Level A**

Level A protection consists of the items required for Level B protection with the addition of a fully-encapsulating, vapor-proof suit capable of maintaining positive pressure.

## **5.3 SUPPLIED-AIR RESPIRATORS**

If air monitoring shows that Level B protection is needed, OHM personnel will wear Survivair 9881-02 Hippack Airline respirators with 5-minute egress bottles. Personnel requiring Level "B" protection and high mobility will wear Survivair Mark 2 SCBA units.

## **5.4 BREATHING-AIR QUALITY**

Code of Federal Regulations 29 CFR 1910.134 states breathing air will meet the requirement of the specification for Grade D breathing air as described in the ANSI/CGA Specification G-7.1-1989. OHM requires a certificate of analysis from vendors of breathing air in order to

show that the air meets this standard. Breathing air will be obtained in cylinders exclusively and will be stationed in the exclusion zone (EZ).

## **5.5 AIR-PURIFYING RESPIRATORS**

A NIOSH-approved full-face respirator with appropriate air-purifying cartridges will be used for Level C work.

## **5.6 RESPIRATOR CARTRIDGES**

The crew members working in Level C will wear respirators equipped with air-purifying cartridges approved for the following contaminants.

- Organic vapors <1,000 ppm
- Chlorine gas <10 ppm
- Hydrogen chloride <50 ppm
- Sulfur dioxide <50 ppm
- Dusts, fumes and mists with a TWA <0.05 mg/m<sup>3</sup>
- Asbestos-containing dusts and mists
- Radionuclides

## **5.7 CARTRIDGE CHANGES**

All cartridges will be changed a minimum of once daily, or more frequently if personnel begin to experience increased inhalation resistance or breakthrough of a chemical warning property. Cartridges will be labeled with the date service began.

## **5.8 INSPECTION AND CLEANING**

Respirators are checked periodically by a qualified individual and inspected before each use by the wearer. All respirators and associated equipment will be decontaminated and hygienically cleaned after each use.

## **5.9 FIT TESTING**

All personnel required to wear an air-purifying respirator as part of their employment will be fit-tested at the time of assignment and a minimum of annually thereafter. The test will use isoamyl acetate or irritant smoke. The fit test must be for the style and size of the respirator to be used.

## **5.10 FACIAL HAIR**

Personnel who have facial hair which interferes with the respirator's sealing surface will not be permitted to wear a respirator and will not be permitted to work in areas requiring respirator use.

### **5.11 CORRECTIVE LENSES**

Normal eyeglasses cannot be worn under full-face respirators because the temple bars interfere with the respirator's sealing surfaces. For workers requiring corrective lenses, special spectacles designed for use with respirators will be provided.

### **5.12 CONTACT LENSES**

Contact lenses will not be worn with any type of respirator.

### **5.13 MEDICAL CERTIFICATION**

Only workers who have been certified by a physician as being physically capable of respirator usage will be issued a respirator. Personnel unable to pass a respiratory fit test or without medical clearance for respirator use will not be permitted to enter or work in areas on site that require respiratory protection. Employees receive a written physicians opinion that they are fit for general hazardous waste operations as per 29 CFR 1910.120(f)(7).

### **5.14 SITE-SPECIFIC RESPIRATORY PROTECTION PROGRAM**

The primary objective of respiratory protection is to prevent employee exposure to atmospheric contamination. When engineering measures to control contamination are not feasible, or while they are being implemented, personal respiratory protective devices will be used.

The criteria for determining respirator need have been evaluated based on the site contaminants and expected levels of protection are outlined in Section 5.1. Air monitoring will be conducted to confirm that respiratory protection levels are adequate (Section 7.0). All respirator users are OSHA trained in proper respirator use and maintenance. The SS and SSO will observe workers during respirator use for signs of stress. The SS, CIH, and SSO will also evaluate this HASP periodically to determine its continued effectiveness with regard to respiratory protection. All persons assigned to use respirators will have medical clearance to do so.

## **6.0 DECONTAMINATION PROCEDURES**

---

This section describes the procedures necessary to en-sure that both personnel and equipment are free from contamination when they leave the work site.

### **6.1 PERSONNEL DECONTAMINATION**

Decontamination procedures will en-sure that material which workers may have contacted in the EZ does not result in personal exposure and is not spread to clean areas of the site. This sequence describes the general decontamination procedure. The specific stages will vary depending on the work area, the task, the protection level, etc.

1. Go to end of EZ
2. Wash outer boots and gloves in detergent solution
3. Rinse outer boots and gloves in water
4. Remove outer boots and let dry
5. Remove outer gloves and let dry
6. Cross into CRZ
7. Remove SCBA or hip pack (Level B)
8. Remove first pair sample gloves
9. Remove outer saran or tyvek
10. Remove and wash respirator
11. Rinse respirator and hang to dry
12. Remove second pair sample gloves and discard

#### **6.1.1 Suspected Contamination**

Any employee suspected of sustaining skin contact with chemical materials will first use the emergency shower. Following a thorough drenching, the worker will proceed to the decontamination facility. Here the worker will remove clothing, shower, don clean clothing, and immediately be taken to the first-aid station. Medical attention will be provided as determined by the degree of injury.

#### **6.1.2 PERSONAL HYGIENE**

Before any eating, smoking, or drinking, personnel will wash hands, arms, neck and face. A personnel decontamination facility will be provided for site operations consisting of showers, change rooms, and separate lockers for street clothes and work clothes. Site personnel are required to shower daily at the completion of that day's work. Also, eye wash facilities and emergency showers will be provided at personnel decontamination facilities and at the water treatment system where hazardous chemicals are handled.

### **6.2 EQUIPMENT DECONTAMINATION**

All contaminated equipment will be decontaminated before leaving the site. Decontamination procedures will vary de-pending upon the contaminant involved, but may

include sweeping, wiping, scraping, hosing, or steaming the exterior of the equipment. Personnel performing this task will wear the proper PPE as prescribed by the SSO.

### **6.3 DISPOSAL**

All decontamination liquids and disposable clothing will be collected, containerized and treated as contaminated waste, unless determined otherwise by accepted testing methods. Wastes will be disposed of according to state and federal regulations.

## 7.0 AIR MONITORING

---

Air monitoring will be conducted in order to determine airborne contamination levels. This ensures that respiratory protection is adequate to protect personnel against the chemicals that are encountered. The following air monitoring efforts will be used at this site. Additional air monitoring may be conducted at the discretion of the SSO.

The following chart describes the air monitoring required and appropriate action levels.

Monitoring Device/Frequency	Action Level	Action
LEL/O <sub>2</sub> (work area) To be performed initial and four times daily during Task 2 and 6 and prior to and during confined space/line entries	>10% LEL <20.8% O <sub>2</sub>	Evacuate area, ventilate, upgrade to Level B if necessary, continue to monitor
PID (breathing zone) To be performed initially and four times daily during Tasks 2, 3, 4, 6, 9, 10, 11, and 12 and prior to and during confined space/line entries	10 meter units for 5 min. 500 meter units for 5 min.	Level C and monitor using benzene detector tubes Shutdown operations and allow vapors to dissipate to less than 100 ppm before continuing
Benzene detector tubes When PID breathing zone readings are 10 meter units or greater every two hours	.5 ppm 25 ppm	Level C Shutdown operations and allow vapors to dissipate to less than 5 ppm before continuing

### 7.1 LOWER EXPLOSIVE LIMIT/OXYGEN (LEL/O<sub>2</sub>) METER

Prior to entering a confined-space area or performing hot work involving welding, cutting, or other high heat-producing operations where flammable or combustible vapors may be present, LEL/O<sub>2</sub> measurements will be taken.

### 7.2 PHOTOIONIZATION DETECTOR (PID)

A PID will be used to monitor total ionizable organic content of the ambient air. A PID will prove useful as a direct reading instrument to aid in determining if respiratory protection needs to be upgraded and to define the EZ.

For known contaminants only, to determine a protection level from PID data, the SSO will multiply the TLV of the known compound by 25. This will be the limit for Level C protection for that compound. If PID readings exceed 25 times the TLV, Level B protection will be required. Also, regardless of the TLV, a PID reading of 1,000 ppm or more will indicate that the GMC-H cartridges may become overloaded and will necessitate Level B protection. (Note: PID readings do not always indicate the actual air concentration of a compound. Consult the manual, HNU, or the CIH for clarification.)



The SSO will take measurements before operations begin in an area to determine the amount of organic compounds naturally occurring in the air. This is referred to as a background level.

Levels of volatile organic compounds will be measured in the air at active work sites once every hour and at the support zone once every hour when levels are detected above background in the exclusion zone. If levels exceed background at any time in the support zone, work in the exclusion zone will cease and corrective actions will be taken-, e.g., cover soil with polyethylene sheeting. Work will not resume until levels reach background in the support zone.

### **7.3 AIR MONITORING LOG**

The SSO will ensure that all air-monitoring data is logged into a monitoring notebook. Data will include all information identified in Procedure 12 of the ER Safety Procedures Manual. The Project CIH will periodically review this data

### **7.4 CALIBRATION REQUIREMENTS**

The PID, LEL/O2 meter and sampling pumps required with fixed-media air sampling will be calibrated daily prior to and after each use. A separate log will be kept detailing date, time, span gas, or other standard, and name of person performing the calibration.

### **7.5 AIR MONITORING RESULTS**

Air monitoring results will be posted for personnel inspection, and will be discussed during morning safety meetings.

## 8.0 EMERGENCY RESPONSE

---

### 8.1 PRE-EMERGENCY PLANNING

Prior to engaging in construction/remediation activities at the site, OHM will plan for possible emergency situations and have available adequate supplies and manpower to respond. The PM will coordinate this plan with the NOSC/NOSCDR prior to commencing work. In addition site personnel will receive training during the site orientation concerning proper emergency response procedures. This training will include review of the elements of this plan and all action procedures described herein.

The following situations would warrant implementation of the Emergency Response and Contingency Plan (ERCP):

Fire/Explosion	<ul style="list-style-type: none"><li>• The potential for human injury exists</li><li>• Toxic fumes or vapors are released</li><li>• The fire could spread on site or off site and possibly ignite other flammable materials or cause heat-induced explosions</li><li>• The use of water and/or chemical fire suppressants could result in contaminated run-off</li><li>• An imminent danger of explosion exists</li></ul>
Spill or Release of Hazardous Materials	<ul style="list-style-type: none"><li>• The spill could result in the release of flammable liquids or vapors, thus causing a fire or gas explosion hazard</li><li>• The spill could cause the release of toxic liquids or fumes in sufficient quantities or in a manner that is hazardous to or could endanger human health</li></ul>
Spill or Release of High Temperature Liquid or Vapor	<ul style="list-style-type: none"><li>• The spill can be contained on site, but the potential exists for ground-water contamination</li><li>• The spill cannot be contained on site, resulting in off-site soil contamination and/or ground-water or surface water pollution</li><li>• The spill quantity is greater than the reportable quantity limit for the material</li></ul>
Natural Disaster	<ul style="list-style-type: none"><li>• A rain storm exceeds the flash flood level</li><li>• The facility is in a projected tornado path or a tornado has damaged facility property</li><li>• Severe wind gusts are forecasted or have occurred and have caused damage to the facility</li></ul>
Medical Emergency	<ul style="list-style-type: none"><li>• Overexposure to hazardous materials</li><li>• Trauma injuries (broken bones, severe lacerations/bleeding, burns)</li><li>• Eye/skin contact with hazardous materials</li><li>• Loss of consciousness</li><li>• Heat stress (Heat stroke)</li><li>• Cold stress (Hypothermia)</li><li>• Heart attack</li><li>• Respiratory failure</li><li>• Allergic reaction</li></ul>

The following measures will be taken to assure the availability of adequate equipment and manpower resources:

- Sufficient equipment and materials will be kept on site and dedicated for emergencies only. The inventory will be replenished after each use.
- On-site emergency responders will be current in regards to training and medical surveillance programs. Copies of all applicable certificates will be kept on file for on-site personnel required to respond.
- It will be the responsibility of the emergency coordinator to brief the on-site response team on anticipated hazards at the site. The emergency coordinator shall also be responsible for anticipating and requesting equipment that will be needed for response activities.
- Emergency response activities will be coordinated with the Local Emergency Planning Committee (LEPC) in compliance with SARA Title III requirements.

Communications will be established prior to commencement of any activities at the remediation site. Communication will be established so that all responders on site have availability to all pertinent information to allow them to conduct their activities in a safe and healthful manner. The primary communication device will be two-way radios. Air horns may be used to alert personnel of emergency conditions. A telephone will be located at the command post to summon assistance in an emergency.

Primary communication with local responders in the event of an emergency will be accomplished using commercial telephone lines.

## **8.2 EMERGENCY RECOGNITION AND PREVENTION**

Because unrecognized hazards may result in emergency incidents, it will be the responsibility of the Site Supervisor and Site Safety Officer, through daily site inspections and employee feedback (Safety Observation Program, daily safety meetings, and activity hazard analyses) to recognize and identify all hazards that are found at the site. These may include:

Chemical Hazards	<ul style="list-style-type: none"> <li>• Materials at the site</li> <li>• Materials brought to the site</li> </ul>
Physical Hazards	<ul style="list-style-type: none"> <li>• Fire/explosion</li> <li>• Slip/trip/fall</li> <li>• Electrocution</li> <li>• Confined space</li> <li>• IDLH atmospheres</li> <li>• Excessive noise</li> </ul>
Mechanical Hazards	<ul style="list-style-type: none"> <li>• Heavy equipment</li> <li>• Stored energy system</li> <li>• Pinch points</li> <li>• Electrical equipment</li> <li>• Vehicle traffic</li> </ul>
Environmental Hazards	<ul style="list-style-type: none"> <li>• Electrical Storms</li> <li>• High winds</li> <li>• Heavy Rain/Snow</li> <li>• Temperature Extremes (Heat/Cold Stress)</li> <li>• Poisonous Plants/Animals</li> </ul>

Once a hazard has been recognized, the Site Supervisor and/or the SSO will take immediate action to prevent the hazard from becoming an emergency. This may be accomplished by the following:

- Daily safety meeting
- Task-specific training prior to commencement of activity
- Lockout/tagout
- Personal Protective Equipment (PPE) selection/use
- Written and approved permits for hot work, confined space
- Trenching/shoring procedure
- Air monitoring
- Following all OHM standard operating procedures
- Practice drills for fire, medical emergency, and hazardous substances spills

**Table 8.1**  
**Emergency Telephone Numbers**

<u>Local Agencies</u> All Services		
Police Department	911 (on-base)	(910) 451-3855 (off-base)
Fire Department	911 (on-base)	
Ambulance	911 (on-base)	(910) 455-9119 (off-base)
Hospital		
USMC Base Hospital (on base)/	(910) 451-4840 (on base)	
Onslow County	(910) 577-2240 (off-base)	
Hospital (off-base)		
NOSC/NOSCDR	(904) 772-5216	
Regional Poison Control Center	(800) 672-1697	
State Agencies		
State Highway Patrol	(800) 441-6127	
Federal Agencies		
EPA Region Branch Response Center	(404) 347-3931	
National Response Center	(800) 424-8802	
Agency for Toxic Substances and Disease Registry	(404) 639-0615 (24 hour)	
NAVY ROICC/NTR		
National Response Center	(800) 424-8802	
Project Manager		
Jim Dunn	(770) 734-8072	
Director Health and Safety,		
Angelo Liberatore, CIH	(770) 453-7671	
OHM Corporation	(800) 537-9540 (24 hour)	

Note: Additional phone numbers in Section 2.0 this HASP.

### **8.3 PERSONNEL ROLES, LINES OF AUTHORITY, AND COMMUNICATIONS**

This section of the ERCP describes the various roles, responsibilities, and communication procedures that will be followed by personnel involved in emergency responses.

The primary emergency coordinator for this site is the Site Supervisor. In the event an emergency occurs and the emergency coordinator is not on site, the Site Safety Officer or the highest ranking employee on site will serve as the emergency coordinator until he arrives. The emergency coordinator will determine the nature of the emergency and take appropriate action as defined by this ERCP.

The emergency coordinator will implement the ERCP immediately as required. The decision to implement the plan will depend upon whether the actual incident threatens human health or the environment. Immediately after being notified of an emergency incident, the

emergency coordinator or his designee will evaluate the situation to determine the appropriate action.

### **8.3.1 Responsibilities and Duties**

This section describes the responsibilities and duties assigned to the emergency coordinator.

It is recognized that the structure of the "Incident Command System" will change as additional response organizations are added. OHM will follow procedures as directed by the fire department, LEPC, State and Federal Agencies as required. OHM will defer to the local Fire Department chief to assume the role of Incident Commander upon arriving on site. Additional on-site personnel may be added to the Site Emergency Response Team as required to respond effectively.

### **8.3.2 On-site Emergency Coordinator Duties**

The on-site emergency coordinator is responsible for implementing and directing the emergency procedures. All emergency personnel and their communications will be coordinated through the emergency coordinator. Specific duties are as follows:

- Identify the source and character of the incident, type and quantity of any release. Assess possible hazards to human health or the environment that may result directly from the problem or its control.
- Discontinue operations in the vicinity of the incident if necessary to ensure that fires, explosions, or spills do not recur or spread to other parts of the site. While operations are dormant, monitor for leaks, pressure build-up, gas generation, or ruptures in valves, pipes, or other equipment, where appropriate.
- Notify the NOSC/NOSCDR if outside emergency response help is necessary to control the incident. Table 8.1 provides telephone numbers for emergency assistance.
- Direct on-site personnel to control the incident until, if necessary, outside help arrives.
- Ensure that the building or area where the incident occurred and the surrounding area are evacuated and shut off possible ignition sources, if appropriate. The Emergency Response Team is responsible for directing site personnel such that they avoid the area of the incident and leave emergency control procedures unobstructed.
- If fire or explosion is involved, notify Base Fire Department.
- Notify LANTDIV ROICC
- Notify OHM Project Manager
- Have protected personnel, in appropriate PPE, on standby for rescue.

If the incident may threaten human health or the environment outside of the site, the emergency coordinator should immediately determine whether evacuation of area outside of the site may be necessary and, if so, notify the Police Department and the Office of Emergency Management.

When required (as determined by the NOSC/NOSCDR), notify the National Response Center. The following information should be provided to the National Response Center:

- Name and telephone number
- Name and address of facility
- Time and type of incident
- Name and quantity of materials involved, if known
- Extent of injuries
- Possible hazards to human health or the environment outside of the facility.

The emergency telephone number for the National Response Center is 800-424-8802.

If hazardous waste has been released or produced through control of the incident, ensure that:

- Waste is collected and contained.
- Containers of waste are removed or isolated from the immediate site of the emergency.
- Treatment or storage of the recovered waste, contaminated soil or surface water, or any other material that results from the incident or its control is provided.
- Ensure that no waste that is incompatible with released material is treated or stored in the facility until cleanup procedures are completed.
- Ensure that all emergency equipment used is decontaminated, recharged, and fit for its intended use before operations are resumed.
- Notify the USEPA Regional Administrator that cleanup procedures have been completed and that all emergency equipment is fit for its intended use before resuming operations in the affected area of the facility. The USEPA Regional Administrator's telephone number is included in the Emergency Contacts.
- Record time, date, and details of the incident, and submit a written report to the USEPA Regional Administrator. Report is due to USEPA within 15 days of the incident.
- Perform post incident evaluation and response critique and submit a written report to the Regional Health and Safety Director within 30 days of the incident conclusion.

## **8.4 SAFE DISTANCES AND PLACES OF REFUGE**

The emergency coordinator for all activities will be the SS. No single recommendation can be made for evacuation or safe distances because of the wide variety of emergencies which could occur. Safe distances can only be determined at the time of an emergency based on a combination of site and incident-specific criteria. However, the following measures are established to serve as general guidelines.

In the event of minor hazardous materials releases (small spills of low toxicity), workers in the affected area will report initially to the contamination reduction zone. Small spills or leaks (generally less than 55 gallons) will require initial evacuation of at least 50 feet in all directions to allow for cleanup and to prevent exposure. After initial assessment of the extent of the release and potential hazards, the emergency coordinator or his designee will determine the specific boundaries for evacuation. Appropriate steps such as caution tape, rope, traffic cones, barricades, or personal monitors will be used to secure the boundaries.

In the event of a major hazardous material release (large spills of high toxicity/greater than 55 gallons), workers will be evacuated from the building/site. Workers will assemble at the entrance to the site for a head count by their foremen and to await further instruction.

If an incident may threaten the health or safety of the surrounding community, the public will be informed and, if necessary, evacuated from the area. The emergency coordinator, or his designee will inform the proper agencies in the event that this is necessary. Telephone numbers are listed in Table 8.1.

Places of refuge will be established prior to the commencement of activities. These areas must be identified for the following incidents:

- Chemical release
- Fire/explosion
- Power loss
- Medical emergency
- Hazardous weather

In general, evacuation will be made to the crew trailers, unless the emergency coordinator determines otherwise. It is the responsibility of the emergency coordinator to determine when it is necessary to evacuate personnel to off-site locations.

In the event of an emergency evacuation, all the employees will gather at the entrance to the site until a head count establishes that all are present and accounted for. No one is to leave the site without notifying the emergency coordinator.

## **8.5 EVACUATION ROUTES AND PROCEDURES**

All emergencies require prompt and deliberate action. In the event of an emergency, it will be necessary to follow an established set of procedures. Such established procedures will be followed as closely as possible. However, in specific emergency situations, the emergency



coordinator may deviate from the procedures to provide a more effective plan for bringing the situation under control. The emergency coordinator is responsible for determining which situations require site evacuation.

### **8.5.1 Evacuation Signals and Routes**

Two-way radio communication and an air horn will be used to notify employees of the necessity to evacuate an area or building involved in a release/spill of a hazardous material. Each crew supervisor will have a two way radio. A base station will be installed in the OHM office trailer to monitor for emergencies. Total site evacuation will be initiated only by the emergency coordinator; however, in his absence, decision to preserve the health and safety of employees will take precedence. Evacuation routes will be posted in each outside work area. Signs inside buildings will be posted on walls or other structural element of a building. Periodic drills will be conducted to familiarize each employee with the proper routes and procedures.

### **8.5.2 Evacuation Procedures**

In the event evacuation is necessary, the following actions will be taken:

- The emergency signal will be activated.
- No further entry of visitors, contractors, or trucks will be permitted. Vehicle traffic within the site will cease in order to allow safe exit of personnel and movement of emergency equipment.
- Shut off all machinery if safe to do so.
- ALL on-site personnel, visitors, and contractors in the support zone will assemble at the entrance to the site for a head count and await further instruction from the emergency coordinator.
- ALL persons in the exclusion zone and contamination reduction zone will be accounted for by their immediate crew leaders (e.g., foreman). Leaders will determine the safest exits for employees and will also choose an alternate exit if the first choice is inaccessible.
- During exit, the crew leader should try to keep the group together. Immediately upon exit, the crew leader will account for all employees in his crew.
- Upon completion of the head count, the crew leader will provide the information to the emergency coordinator.
- Contract personnel and visitors will also be accounted for.
- The names of emergency response team members involved will be reported to the emergency spill control coordinator.

- A final tally of persons will be made by the emergency coordinator or designee. No attempt to find persons not accounted for will involve endangering lives of OHM or other employees by reentry into emergency areas.
- In all questions of accountability, immediate crew leaders will be held responsible for those persons reporting to them. Visitors will be the responsibility of those employees they are seeing. Contractors and truck drivers are the responsibility of the Site Supervisor. The security guard will aid in accounting for visitors, contractors, and truckers by reference to sign-in sheets available from the guard shack.
- Personnel will be assigned by the emergency coordinator to be available at the main gate to direct and brief emergency responders.
- Reentry into the site will be made only after clearance is given by the emergency coordinator. At his direction, a signal or other notification will be given for reentry into the facility.
- Drills will be held periodically to practice all of these procedures and will be treated with the same seriousness as an actual emergency.

## **8.6 EMERGENCY SPILL RESPONSE PROCEDURES AND EQUIPMENT**

In the event of an emergency involving a hazardous material spill or release, the following general procedures will be used for rapid and safe response and control of the situation. Emergency contacts found in Table 8.1 provide a quick reference guide to follow in the event of a major spill.

### **8.6.1 Notification Procedures**

If an employee discovers a chemical spill or process upset resulting in a vapor or material release, he or she will immediately notify the on-site emergency coordinator.

The on-site Emergency Coordinator will obtain information pertaining to the following:

- The material spilled or released.
- Location of the release or spillage of hazardous material.
- An estimate of quantity released and the rate at which it is being released.
- The direction in which the spill, vapor or smoke release is heading.
- Any injuries involved.
- Fire and/or explosion or possibility of these events.
- The area and materials involved and the intensity of the fire or explosion.

This information will help the on-site emergency coordinator to assess the magnitude and potential seriousness of the spill or release.

## 8.6.2 Procedure for Containing/Collecting Spills

The initial response to any spill or discharge will be to protect human health and safety, and then the environment. Identification, containment, treatment, and disposal assessment will be the secondary response.

If for some reason a chemical spill is not contained within a dike or sump area, an area of isolation will be established around the spill. The size of the area will generally depend on the size of the spill and the materials involved. If the spill is large (greater than 55 gallons) and involves a tank or a pipeline rupture, an initial isolation of at least 100 ft. in all directions will be used. Small spills (less than or equal to 55 gallons) or leaks from a tank or pipe will require evacuation of at least 50 ft. in all directions to allow cleanup and repair and to prevent exposure. When any spill occurs, only those persons involved in overseeing or performing emergency operations will be allowed within the designated hazard area. If possible the area will be roped or otherwise blocked off.

If the spill results in the formation of a toxic vapor cloud (by reaction with surrounding materials or by outbreak of fire) and its release (due to high vapor pressures under ambient conditions), further evacuation will be enforced. In general an area at least 500 feet wide and 1,000 feet long will be evacuated downwind if volatile materials are spilled. (Consult the DOT Emergency Response Guide for isolation distances for listed hazardous materials.)

If an incident may threaten the health or safety of the surrounding community, the public will be informed and possibly evacuated from the area. The on-site emergency coordinator will inform the proper agencies in the event this is necessary. (Refer to Table 8.1)

As called for in regulations developed under the Comprehensive Environmental Response Compensation Liability Act of 1980 (Superfund), OHM's practice is to report a spill of a pound or more of any hazardous material for which a reportable quantity has not been established and which is listed under the Solid Waste Disposal Act, Clean Air Act, Clean Water Act, or TSCA. OHM also follows the same practice for any substances not listed in the Acts noted above but which can be classified as a hazardous waste under RCRA.

Clean up personnel will take the following measures:

- Make sure all unnecessary persons are removed from the hazard area.
- Put on protective clothing and equipment.
- If a flammable material is involved, remove all ignition sources, and use spark and explosion proof equipment for recovery of material.
- Remove all surrounding materials that could be especially reactive with materials in the waste. Determine the major components in the waste at the time of the spill.

- If wastes reach a storm sewer, try to dam the outfall by using sand, earth, sandbags, etc. If this is done, pump this material out into a temporary holding tank or drums as soon as possible.
- Place all small quantities of recovered liquid wastes (55 gallons or less) and contaminated soil into drums for incineration or removal to an approved disposal site.
- Spray the spill area with foam, if available, if volatile emissions may occur.
- Apply appropriate spill control media (e.g. clay, sand, lime, etc.) to absorb discharged liquids.
- For large spills, establish diking around leading edge of spill using booms, sand, clay or other appropriate material. If possible, use diaphragm pump to transfer discharged liquid to drums or holding tank.

### 8.6.3 Emergency Response Equipment

The following equipment will be staged in the support zone and throughout the site, as needed, to provide for safety and first aid during emergency responses:

- ABC-type fire extinguisher
- First-aid kit, industrial size
- Eyewash/safety shower (This equipment will be in conformance with ANSI Z358.1-1990.)
- Emergency oxygen unit
- Emergency signal horn
- Self contained breathing apparatus (two)
- Stretcher/backboard

In addition to the equipment listed above, OHM maintains direct reading instrumentation that may be used in emergency situations to assess the degree of environmental hazard. This equipment will only be used by the Site Safety Officer or other specially trained personnel. This equipment will be stored, charged and ready for immediate use in evaluating hazardous chemical concentrations. The equipment will be located at the OHM office trailer.

EQUIPMENT NAME	APPLICATION
Portable H-NU Photoionization Meter	Measures selected inorganic and organic chemical concentrations
MSA Oxygen and Combustible Gas Meter	Measures oxygen and combustible gas levels
Draeger Detector Tubes	Assorted detector tubes to measure specific chemical concentrations

### 8.6.4 Personal Protective Equipment

A supply of two (minimum) SCBAs will be located in the support zone for use in emergency response to hazardous materials releases. They will be inspected at least monthly, according to OSHA requirements. In addition, all emergency response personnel will have respirators

available for use with cartridge selection determined by the Site Safety Officer based on the results of direct reading instruments. Emergency response personnel will also be provided with protective clothing as warranted by the nature of the hazardous material and as directed by the Site Safety Officer. All OHM personnel who may be expected to wear SCBAs are trained at assignment and annually thereafter on the proper use and maintenance of SCBAs and airline respirators.

### **8.6.5 Emergency Spill Response Clean-Up Materials and Equipment**

A sufficient supply of appropriate emergency response clean-up and personal protective equipment will be inventoried and inspected, visually, on a weekly basis.

The materials listed below will be kept on site for spill control, depending on the types of hazardous materials present on site. The majority of this material will be located in the support zone, in a supply trailer or storage area. Small amounts will be placed on pallets and located in the active work areas.

- Sand or clay to solidify/absorb liquid spills.
- Lime (calcium oxide), soda ash (sodium carbonate), or baking soda (sodium bicarbonate) for neutralizing acid (pH <7) spills.
- Activated charcoal (carbon) to adsorb organic solvents (hydrocarbons) and to reduce flammable vapors.
- Citric acid for neutralizing caustic (pH >7) spills.
- Vapor-suppressing foam, if required by the Client, for controlling the release of volatile organic compounds.
- Appropriate solvents e.g. CITRIKLEEN, for decontamination of structures or equipment.

The following equipment will be kept on site and dedicated for spill cleanup:

- Plastic shovels for recovering corrosive and flammable materials.
- Sausage-shaped absorbent booms for diking liquid spills, drains, or sewers.
- Sorbent sheets (diapers) for absorbing liquid spills.
- Overpack drums for containerizing leaking drums.
- 55-gallon open-top drums for containerization of waste materials.

\*NOTE: All contaminated soils, absorbent materials, solvents and other materials resulting from the clean-up of spilled or discharged substances shall be properly stored, labeled, and disposed of off-site.

## 8.7 EMERGENCY CONTINGENCY PLAN

This section of the ERCP details the contingency measures OHM will take to prepare for and respond to fires, explosions, spills and releases of hazardous materials, hazardous weather, and medical emergencies.

### 8.7.1 Medical Emergency Contingency Measures

The procedures listed below will be used to respond to medical emergencies. The SSO will contact the local hospital and inform them of the site hazards and potential emergency situations. A minimum of two First-Aid/CPR trained personnel will be maintained on site. All OHM first aid and CPR Responders have received training as required by 29 CFR 1910.1030 Bloodborne Pathogen Standard. A copy of the OHM exposure control plan may be obtained from the Site Safety Officer or Regional Health and Safety Director.

#### 8.7.1.1 Response

The nearest workers will immediately assist a person who shows signs of medical distress or who is involved in an accident. The crew foreman will be summoned.

The crew foreman will immediately make radio contact with the on-site emergency coordinator to alert him of a medical emergency situation. The foreman will advise the following information:

- Location of the victim at the work site
- Nature of the emergency
- Whether the victim is conscious
- Specific conditions contributing to the emergency, if known

The Emergency Coordinator will notify the Site Safety Officer. The following actions will then be taken depending on the severity of the incident:

#### ***Life-Threatening Incident***

If an apparent life-threatening condition exists, the crew foreman will inform the emergency coordinator by radio, and the local Emergency Response Services (EMS) will be immediately called. An on-site person will be appointed who will meet the EMS and have him/her quickly taken to the victim. Any injury within the EZ will be evacuated by OHM personnel to a clean area for treatment by EMS personnel. No one will be able to enter the EZ without showing proof of training, medical surveillance and site orientation.

#### ***Non Life-Threatening Incident***

If it is determined that no threat to life is present, the Site Safety Officer will direct the injured person through decontamination procedures (see below) appropriate to the nature of the illness or accident. Appropriate first aid or medical attention will then be administered.

\*NOTE: The area surrounding an accident site must not be disturbed until the scene has been cleared by the Site Safety Officer.

Any personnel requiring emergency medical attention will be evacuated from exclusion and contamination reduction zones if doing so would not endanger the life of the injured person or otherwise aggravate the injury. Personnel will not enter the area to attempt a rescue if their own lives would be threatened. The decision whether or not to decontaminate a victim prior to evacuation is based on the type and severity of the illness or injury and the nature of the contaminant. For some emergency victims, immediate decontamination may be an essential part of life-saving first aid. For others, decontamination may aggravate the injury or delay life-saving first aid. Decontamination will be performed if it does not interfere with essential treatment.

If decontamination can be performed, observe the following procedures:

- Wash external clothing and cut it away.

If decontamination cannot be performed, observe the following procedures:

- Wrap the victim in blankets or plastic to reduce contamination of other personnel.
- Alert emergency and off-site medical personnel to potential contamination, instruct them about specific decontamination procedures.
- Send site personnel familiar with the incident and chemical safety information, e.g. MSDS, with the affected person.

All injuries, no matter how small, will be reported to the SSO or the Site Supervisor. An accident/injury/illness report will be completely and properly filled out and submitted to the Regional Health and Safety Director/Project CIH, in accordance with OHM's reporting procedures.

A list of emergency telephone numbers is given in Table 8.1.

#### **8.7.1.2 Notification**

The following personnel/agencies will be notified in the event of a medical emergency:

- Local Fire Department or EMS
- On-site Emergency Coordinator
- Workers in the affected areas
- Client Representative

#### **8.7.1.3 Directions To Hospital**

Written directions to the hospital and a map will be posted in all trailers in the staging area. Directions to the hospital are as follows:

Routes to hospital: (MAPS ARE POSTED ON-SITE)

**ON-BASE:**

1. From Site 78 proceed west to Holcomb Blvd. and turn left (north).
2. Proceed north on Holcomb Blvd. and turn left on Brewster Street.
3. Base hospital is approximately ½ mile ahead on right.
4. Follow signs to the emergency room entrance.

**OFF-BASE**

1. From Site 78 proceed west to Holcomb Blvd. and turn left (north).
2. Proceed north on Holcomb Blvd. and exit MCB Camp Lejeune through the main gate.
3. Follow Highway 24 west (approximately 2.4 miles) to Western Blvd. and turn right (north).
4. Continue on Western Blvd. (approximately 1.5 miles) to the first stoplight and the hospital is on the left side of the street.
5. Follow signs to the emergency room entrance.

A map depicting the route to the Onslow County Memorial Hospital and the Base Naval Hospital will be posted in each trailer.

**8.7.2 Fire Contingency Measures**

OHM personnel and subcontractors are not trained professional firefighters. Therefore, if there is any doubt that a fire can be quickly contained and extinguished, personnel will notify the emergency coordinator by radio and vacate the structure or area. The emergency coordinator will immediately notify the local Fire Department.

The following procedures will be used to prevent the possibility of fires and resulting injuries:

- Sources of ignition will be kept away from where flammable materials are handled or stored.
- The air will be monitored for explosivity before and during hot work and periodically where flammable materials are present. Hot work permits will be required for all such work.
- “No smoking” signs will be conspicuously posted in areas where flammable materials are present.
- Fire extinguishers will be placed in all areas where a fire hazard may exist.
- Before workers begin operations in an area the foreman will give instruction on egress procedures and assembly points. Egress routes will be posted in work areas and exit points clearly marked.

The following procedures will be used in the event of a fire:



- Anyone who sees a fire will notify their supervisor who will then contact the Emergency Coordinator by radio. The emergency coordinator will activate the emergency air horns and contact the local Fire Department.
- When the emergency siren sounds, workers will disconnect electrical equipment in use (if possible) and proceed to the nearest fire exit.
- Work crews will be comprised of pairs of workers (buddy system) who join each other immediately after hearing the fire alarm and remain together throughout the emergency. Workers will assemble at a predetermined rally point for a head count.
- When a small fire has been extinguished by a worker, the emergency coordinator will be notified.

### **8.7.3 Hazardous Weather Contingency Measures**

Operations will not be started or continued when the following hazardous weather conditions are present:

- Lightning
- Heavy Rains/Snow
- High Winds

#### **8.7.3.1 Response**

- Excavation/soil stock piles will be covered with plastic liner.
- All equipment will be shut down and secured to prevent damage.
- Personnel will be moved to safe refuge, initially crew trailers. The emergency coordinator will determine when it is necessary to evacuate personnel to off-site locations and will coordinate efforts with fire, police and other agencies.

#### **8.7.3.2 Notification**

The emergency coordinator will be responsible for assessing hazardous weather conditions and notifying personnel of specific contingency measures. Notifications will include:

- OHM employees and subcontractors
- Client Representative
- Local Civil Defense Organization

### **8.7.4 Spill/Release Contingency Measures**

In the event of release or spill of a hazardous material the following measures will be taken.

Any person observing a spill or release will act to remove and/or protect injured/contaminated persons from any life-threatening situation. First aid and/or decontamination procedures will be implemented as appropriate.

First aid will be administered to injured/contaminated personnel. Unsuspecting persons/vehicles will be warned of the hazard. All personnel will act to prevent any unsuspecting persons from coming in contact with spilled materials by alerting other nearby persons. Without taking unnecessary risks, personnel will attempt to stop the spill at the source. This may involve activities such as uprighting a drum, closing a valve or temporarily sealing a hole with a plug.

Utilizing radio communications, the emergency coordinator will be notified of the spill/release, including information on material spilled, quantity, personnel injuries and immediate life threatening hazards. Air monitoring will be implemented by the emergency coordinator and SSO to determine the potential impact on the surrounding community. Notification procedures will be followed to inform on-site personnel and off-site agencies. The emergency coordinator will make a rapid assessment of the spill/release and direct confinement, containment and control measures. Depending upon the nature of the spill, measures may include:

- Construction of a temporary containment berm utilizing on-site clay absorbent earth
- Digging a sump, installing a polyethylene liner and diverting the spill material into the sump placing drums under the leak to collect the spilling material before it flows over the ground
- Transferring the material from its original container to another container

The emergency coordinator will notify the LANTDIV ROICC, of the spill and steps taken to institute clean-up. Emergency response personnel will clean-up all spills following the spill clean-up plan developed by the emergency coordinator. Supplies necessary to clean up a spill will be immediately available on-site. Such items may include, but are not limited to:

- Shovel, rake
- Clay absorbent
- Polyethylene liner
- Personal safety equipment
- Steel drums
- Pumps and miscellaneous hand tools

The major supply of material and equipment will be located in the Support Zone. Smaller supplies will be kept at active work locations. The emergency coordinator will inspect the spill site to determine that the spill has been cleaned up to the satisfaction of the ROICC. If necessary, soil, water or air samples may be taken and analyzed to demonstrate the effectiveness of the spill clean-up effort. The emergency coordinator will determine the cause of the spill and determine remedial steps to ensure that recurrence is prevented. The emergency coordinator will review the cause with the ROICC and obtain his concurrence with the remedial action plan.

## **9.0 TRAINING REQUIREMENTS**

---

As a prerequisite to employment at OHM, all field employees are required to take a 40-hour training class and pass a written examination. This training covers all forms of personal protective equipment, toxicological effects of various chemicals, hazard communication, bloodborne pathogens, handling of unknown tanks and drums confined-space entry procedures, and electrical safety. This course is in full compliance with OSHA requirements in 29 CFR 1910.120. In addition, all employees receive annual 8-hour refresher training and three day on-site training under a trained experienced supervisor. Supervisory personnel receive an additional 8-hour training in handling hazardous waste operations. Copies of certification of this training will be maintained on-site for all workers assigned to this project.

All personnel entering the exclusion zone will be trained in the provisions of this site safety plan and be required to sign the Health and Safety Plan Certification in Appendix A.

## **10.0 MEDICAL SURVEILLANCE PROGRAM**

---

All OHM personnel participate in a medical and health monitoring program. This program is initiated when the employee starts work with a complete physical and medical history and is continued on a regular basis. A listing of OHM's worker medical profile is shown below. This program was developed in conjunction with a consultant toxicologist and OHM's occupational health physician. Other medical consultants are retained when additional expertise is required. Medical certification for all site workers assigned to the project will be maintained on-site.

The medical surveillance program meets the requirements of the OSHA Standard 29 CFR 1910.120 (f).

**Table 10.1  
Worker Medical Profile**

Item	Initial	Annual
Medical History	X	X
Work History	X	X
Visual Acuity and Tonometry	X	X
Pulmonary Function Tests	X	X
Physical Examination	X	X
Audiometry Tests	X	X
Chest X-Ray	X	X
Complete Blood Counts	X	X
Blood Chem. (SSAC-23 or equivalent)	X	X
Urinalysis	X	X
Dermatology Examination	X	X
Electrocardiogram/Stress Test	X	X (based on age)

Specific Tests (as required): None

### **10.1 EXAMINATION SCHEDULE**

Employees are examined initially upon start of employment, annually thereafter, and may be examined upon termination of employment. Unscheduled medical examinations are conducted:

- At employee request after known or suspected exposure to toxic or hazardous materials
- At the discretion of the client, the CIH, SSO, or OHM occupational physician after known or suspected exposure to toxic or hazardous materials

- At the discretion of the OHM occupational physician

All nonscheduled medical examinations will include, as a minimum, all items specified above for periodic surveillance examination, with the exception of the chest x-ray, which will be conducted at the discretion of the occupational physician performing the examination.

**APPENDIX A**

**HEALTH AND SAFETY PLAN CERTIFICATION**

**APPENDIX B**

**OHM HAZARD COMMUNICATION PROGRAM**

## APPENDIX C

### MATERIAL SAFETY DATA SHEETS

Site Chemicals	Hydraulic Oil
Petroleum Hydrocarbons	Hydrogen cyanide (calibration)
Gasoline	Hydrogen sulfide (calibration)
Diesel	Isobutylene (calibration gas)
Jet Fuel	Isopropyl alcohol
Fuel oil	Liquid detergent
Anti-fog	Methane (calibration gas)
Bleach	Motor oil
Breathing air	Oil (hydraulic)
Diesel fuel	Pentane (calibration gas)
Fire extinguishers	Starting fluid
Gasoline	WD-40
Grease	



## **APPENDIX D**

### **SPECIFIC OHM HEALTH AND SAFETY PROCEDURES**

- SOP No. 2-1 Vehicle Safety
- SOP No. 2-3 Personal Lifting Safety
- SOP No. 2-4 Slip, Trip, Fall Prevention
- SOP No. 2-5 Electrical Safety
- SOP No. 2-7 Equipment Inspection
- SOP No. 2-9 Fall Protection
- SOP No. 3-4 Heat Stress Prevention
- SOP No. 4-2 Respiratory Protection
- SOP No. 5-4 Decontamination
- SOP No. 6-1 Confined Space Entry
- SOP No. 6-4 Lockout/Tagout/Try
- SOP No. 6-5 Excavation
- SOP No. 7-1 High Pressure Washers
- SOP No. 7-11 Buried Utility Location and Associated Subsurface Field Activities
- SOP No. 7-14 Equipment Operator Qualification

## **APPENDIX E**

### **HEALTH AND SAFETY FORMS**

Accident/Injury/Illness Report Form  
Accident/Injury/Illness Status Report Form  
First Aid Log  
OHM Safety Rules  
Daily Safety Meeting Log  
Instrument Calibration Logs (LEL/PID)  
Air Monitoring Instrument (Direct Reading) Logs  
Heavy Equipment Inspection Forms  
Fire Extinguisher Checklist/Inventory Form  
SCBA/SAR Inspection Forms  
Project Site Safety Inspection Checklist (weekly)  
SSO Daily Report  
Air Sampling and Analysis Log  
Air Sampling Data Sheet  
Chain-of-Custody Record  
Activity Hazard Analysis



## ***APPENDIX B - OHM HAZARD COMMUNICATION PROGRAM***

---

### **1.0 GENERAL**

The following written hazard communication program has been established for OHM Corporation. The purpose of this program is to transmit information about the various Chemical hazards in the work place to the workers using various media. The transmittal of information will be accomplished by means of a comprehensive hazard communication program, which will include container labeling and other forms of warning, material safety data sheets, and employee training in accordance with 29 CFR 1910.1200 and 29 CFR 1926.59.

The program will be available in corporate and regional Health and Safety Departments for reviews by all employees. It will also be available in the corporate library and clearly marked "Employee Right-to-Know" stations located within each individual shop and on each job site. OHM Corporation will accomplish the hazard communication requirements through formal safety training, departmental safety meetings, and job site safety meetings.

### **2.0 RESPONSIBILITIES**

Purpose: Overall responsibility rests with all corporate officers of OHM Corporation. A brief outline of responsibilities for those persons directly involved with the program will follow. These responsibilities are not all inclusive, but are designed to give guidance in initial and long-term program development since each area is different. These responsibilities may vary.

Scope: This program is intended to cover those employees who are directly involved with the handling of hazardous materials or supervision of those activities.

#### **2.1 HEALTH AND SAFETY DEPARTMENT RESPONSIBILITIES**

1. Review operations with supervisors to determine what tasks require hazard communication training.
2. Advise supervisory people as to which materials may need to be considered hazardous initially and eventually to ensure that hazard task determination is being done according to the written policy.
3. Follow up through safety meetings and safety audits to ensure that supervisors are carrying out prescribed company policy.
4. Notify supervisors of any operating changes affecting the hazardous materials being used.

5. Periodically audit the Hazard Communication Program's progress. Initially, this should be done biweekly, but later the audit may be done on a monthly or quarterly basis.

## **2.2 TRAINING DEPARTMENT RESPONSIBILITIES**

1. Ensure that up-to-date records are maintained on training of all employees required to handle hazardous materials. The supervisor should keep copies of these records and should also send copies of the initial training to the corporate training secretary for the training file.
2. Educate personnel upon initial training to the requirements of the Hazard Communication Standard.

## **2.3 SUPERVISOR RESPONSIBILITIES**

1. Identify jobs requiring the use of hazardous chemicals and provide lists of those jobs and chemicals to the Health and Safety Department.
2. Provide the training required by the Hazard Communication Standard and document training of employees in the safe handling of hazardous materials.
3. Inspect engineering controls and personal protective equipment before each use. Health and Safety can help determine a suitable inspection plan for each application as needed.
4. Make daily surveys of the work area to ensure that safe practices are being followed. Advise employees of unsafe work practices on the first occasion and consider further violations as disciplinary violations.
5. Ensure required labeling practices are being followed. Labeling should be affixed to the container when it arrives. If the contents are transferred to another container, then all label information (manufacturer, product name, and product number) must also be affixed to the new container, so that all containers of the material, regardless of size, are labeled.
6. Enforce all applicable safety and health standards through periodic audits.
7. Before ordering a material, determine if a Material Safety Data Sheet exist on file. Request an MSDS for any material without one.
8. Send all new MSDSs to the Health and Safety Department after making a copy for the Employee Right-to-Know file.

## **2.4 EMPLOYEE RESPONSIBILITIES**

1. Obey established safety rules and regulations
2. Use all safety procedures and personnel protective equipment as required by company procedures
3. Notify supervisor of the following:
  - a. Any symptoms or unusual effects that may be related to the use of hazardous chemicals.
  - b. Any missing or unreadable labels on containers.
  - c. Missing, damaged, or malfunctioning safety equipment.
4. Use approved labels on containers; do not remove labels (labels will be located in the warehouse).
5. Do not use unapproved containers for hazardous materials. (are materials and containers compatible?)
6. Know where emergency equipment and first-aid supplies are located before considering a possibly dangerous task.
7. Know location of Material Safety Data Sheets (MSDSs). These will be located in the "Employee Right-to-know" station for the respective shop/job site.
8. Know what you are expected to do in case of an emergency. Before the commencement of any task, emergency considerations shall be made.

## **2.5 SHIPPING/RECEIVING PERSONNEL RESPONSIBILITIES**

1. Ensure MSDS are received with initial shipment of a hazardous material; if not, contact purchasing to request the appropriate MSDS and also call the Health and Safety Department to determine if there is an MSDS available until the requested MSDS arrives.
2. Ensure labels are affixed to all containers.
3. Store hazardous materials in designated locations.
4. Use proper personal protective equipment when handling hazardous materials.
5. Report damaged containers or spills to the appropriate Health and Safety Department immediately.

6. Request an MSDS from the manufacturer for any hazardous material that arrives in Findlay from a job. Also, a MSDS shall accompany any hazardous material that is sent to a job.

### **3.0 HAZARD DETERMINATION**

OHM Corporation will rely on Material Safety Data Sheets from hazardous chemical supplier to meet hazard determination requirements. Other relevant data from laboratory analyses, chemical reference materials, and chemical manufacturers', written evaluation procedures will be utilized when warranted. No other method shall be used to determine chemical hazard unless approved by the Health and Safety Department.

### **4.0 LABELING**

The shipping and receiving supervisors will be responsible for seeing that all containers arriving at OHM Corporation are properly and clearly labeled. Shipping and receiving supervisors shall also check all labels for chemical identity and appropriate hazard warnings. If the hazardous chemical is regulated by OSHA in a substance specific health standard, the supervisor or department manager shall ensure that the labels or other forms of warning used are in accordance with the requirements of that standard. Any container that is not labeled shall be immediately labeled correctly after initial discovery.

Each supervisor or department manager shall be responsible for seeing that all portable containers used in their work area are properly labeled with chemical identity and hazard warning.

Supervisors or department managers shall also ensure that labels on hazardous chemical containers are not removed or defaced unless the container is immediately marked with the required information and that all labels are legible in English and prominently displayed on the container or readily available in the work area throughout each shift.

If any container is found and the contents cannot be identified, the supervisor or manager shall be contacted immediately. When proper identification is made, a label shall be affixed to the container immediately. If it is discovered that no MSDS is available, the manufacturer and the Health and Safety Department shall be contacted to assist in locating the proper MSDS. If there is no way to identify the material in the container, the container should be set aside, away from all personnel until it can be tested by the Health and Safety Department or laboratory personnel. Supervisors and managers shall communicate their findings or awareness of such containers to all personnel in the area and to those who enter later.

### **5.0 MATERIAL SAFETY DATA SHEETS (MSDSS)**

Each supervisor or department manager at OHM Corporation will be responsible for maintaining a current MSDS relevant to the hazardous chemicals used in their area. The Health and Safety Department will be responsible for compiling the master MSDS file for the

facility and aiding all shops/job sites with the completion and maintenance of their respective MSDS files.

All MSDSs will be readily available for review by all employees during each work shift. Each shop/job site will designate a clearly marked "Employee Right-to-Know" station where employees can immediately obtain a MSDS and the required information in an emergency.

Although manufacturers are required to provide employers with MSDSs on an initial chemical shipment, OHM Corporation purchasing agents (and supervisors purchasing their own material) shall request MSDSs and updates to MSDSs on all purchase orders. Supervisors and department managers that are without proper MSDSs shall be responsible for requesting this information from manufacturers for chemicals. A file of follow-up letters shall be maintained for all hazardous chemical shipments received without MSDSs.

## **6.0 EMPLOYEE INFORMATION AND TRAINING**

It is the responsibility of the supervisor in charge of each employee to ensure that the employee is properly trained. Training employees on chemical hazards and chemical handling is accomplished at the time of initial employment at OHM Corporation, whenever a new chemical (or physical) hazard is introduced into the work area, and through ongoing formal and informal training programs. Additionally, chemical hazards are communicated to employees through daily, morning, shop specific safety meetings, which shall be documented according to topic, major points discussed, and names of those attending (attendance is mandatory). Also, biweekly hazardous chemical safety meetings will be prepared by the Health and Safety Department using similar documentation for shop areas. Attendance is mandatory for these meetings also. Documentation for shop safety meetings will be available in the respective Employee Right-to-know stations and biweekly safety meeting documentation will be available in the Health and Safety Department to all employees for further referencing and questioning. Records of all formal training conducted at OHM Corporation are coordinated and maintained by the Training Department secretary.

At a minimum, OHM Corporation will inform employees on the following:

- The requirements of 29 CFR 1910.1200--Hazard Communication--Evaluating the potential hazards of chemicals and communication of information concerning hazards and appropriate protective measures to employees. This is accomplished in several different ways including, but no limited to, 40-hour OSHA Hazardous Waste Worker Training (29 CFR 1910.120), shop safety meetings, job site safety meetings, Health and Safety Department safety meetings, and formal and informal training about specific chemical hazards.
- The location and availability of the written hazard communication program, list of hazardous chemicals, and MSDS sheets--Notices will be periodically posted on the employee bulletin boards providing the location of the above material.
- Any operations in their work area where hazardous chemicals are present.



- What the company has done to lessen or prevent workers' exposure to these chemicals.

Employee training shall include at least:

- Methods and observations that may be used to detect the presence or release of a hazardous chemical in the work area (monitoring instruments, visual appearance or odor), and acute and chronic health effects.
- The physical and health hazards of chemicals in the work area (accomplished through periodic physical and chemical hazard awareness sessions developed by the Health and Safety Department). These sessions shall serve as chemical hazards refreshers.
- The methods of preventing exposure to hazardous chemicals including the measures OHM Corporation has taken to protect the employees.
- Procedures to follow if OHM Corporation employees are exposed to hazardous chemicals (location of nearest phone, emergency eyewash, and shower will be included). These discussions shall include proper operating procedures for all emergency equipment.
- The details of the hazard communication program developed by OHM Corporation, including an explanation of the labeling system and the Material Safety Data Sheets, and how employees can obtain and use the appropriate hazard information.
- Standard operating procedures within each respective shop. OHM Corporation company policy determines what is considered standard operating procedures.
- Procedures for workers involved in non-routine tasks.

Each supervisor or department manager shall ensure that the above training is emphasized to OHM Corporation employees. The Health and Safety Department will ensure that each shop, department, and job site is properly informing and training all employees through daily group meetings and individual discussions. Whenever a new hazardous chemical is placed into use, the supervisor or department manager shall inform the employees of the hazards which that chemical may pose. The supervisor or manager shall also be responsible for obtaining and making available a MSDS for the new chemical.

## **7.0 HAZARDOUS NON-ROUTINE TASKS**

Occasionally, employees at OHM Corporation are required to perform tasks which are considered to be non-routine. All tasks considered to be non-routine shall be carefully discussed among the supervisor and those performing the task. This safety briefing shall include all possible hazards that may be encountered while completing the task, including:

- Hazard recognition
- Chemicals involved and their hazardous properties

- Physical hazards
- Methods of avoiding all hazards (technical instruments, proper personal protective equipment, etc.)

The following is list of some of the non-routine tasks which may occur at OHM Corporation together with some information needed to complete the tasks safely.

- Confined Space Entry
  - Obtain confined space entry procedure/permit from Health and Safety Department and follow all protocol before beginning task. Complete and have supervisor sign permit before any work begins.
  - Monitor atmosphere with explosimeter, oxygen meter, and any toxic gas meter as may be appropriate.
  - Discuss specific chemical hazards.
  - Discuss protective/safety measures the employee can take (e.g., Personal protective equipment and engineering controls, use of life lines, lock-out/tagout procedures, etc).
  - Measures the company has taken to lessen the hazards including ventilation, respirator, presence of another employee, and emergency procedures.
- Excavation, Trenching, and Shoring
  - Obtain guidelines from Health and Safety Department before beginning task.
  - Comply with all requirements set forth for this activity in 29 CFR Subpart P(excavating, trenching, shoring).
  - Discuss specific chemical hazards.
  - Follow confined space entry procedure above if trench is above shoulder height.
  - Discuss protective/safety measures the employee can take.
  - Review appropriate accident prevention steps.
- Decontamination of Equipment
  - Determine possible contaminants and the hazards associated with them.

- Determine personal protection needed by contacting the Health and Safety Department.
- Alert all personnel in areas of contamination and decontamination
- Contain and secure all contaminated materials and decontamination materials.
- Contact the Health and Safety Department for proper disposal.

It is company policy that no OHM Corporation employee will begin work on any non-routine task without first receiving a safety briefing from their supervisor or a Health and Safety Department representative.

## **8.0 INFORMING CONTRACTORS**

- Hazardous chemicals to which they may be exposed while performing a task including the following:
  - Chemical properties
  - Physical properties
  - Acute/Chronic health effects
- Location of "Employee Right-to Know" station which includes the following:
  - MSDS for work area
  - Hazard Communication Program
  - Other relevant safety material
- Precautionary measures to be taken to protect employees from chemical and physical hazards.
- Location of nearest emergency equipment (fire extinguisher, eyewash, shower, phone, first-aid kit, etc.)
- Procedures to follow in the event of employee exposure.
- Steps OHM Corporation has taken to reduce the risk of exposure to physical and chemical hazards including the following:
  - Safety meetings
  - Hazard Communication Program
  - Proper storage and labeling of hazardous chemicals
  - Health and Safety Department shop audits
- The methods used to label all hazardous chemicals.

The Health and Safety Department shall offer assistance in providing the above information to contractors working at OHM Corporation. On initial visit by a contractor to OHM Corporation, a "Contractor Right-to-Know" release form shall be completed. This form will state that the above information has been communicated to the perspective contract.

**SAMPLING AND ANALYSIS PLAN  
FOR  
CONSTRUCTION OF NEW WELLS  
AT HADNOT POINT INDUSTRIAL AREA  
NORTH AND SOUTH GROUNDWATER TREATMENT PLANTS  
MCB CAMP LEJEUNE, NORTH CAROLINA**

Prepared for:

DEPARTMENT OF THE NAVY  
Contract No. N62470-97-D-5000  
Atlantic Division  
Naval Facilities Engineering Command  
6500 Hampton Boulevard  
Building A (South East Wing) 3rd Floor  
Norfolk, VA 23508

Prepared by:

OHM Remediation Services Corp.  
5445 Triangle Parkway, Suite 400  
Norcross, GA 30092

Reviewed by:

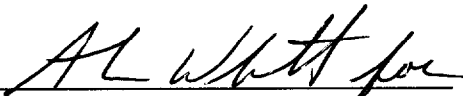
  
James A. Dunn, Jr., P.E.  
Project Manager

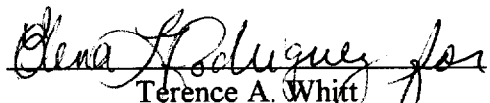
  
Terence A. Whitt  
Manager of Field Analytical Services

  
For John P. Franz, P.E.  
Program Manager

September 1998  
Delivery Order 0175  
Project No. 20500

## **TABLE OF CONTENTS**

---

<b>1.0 INTRODUCTION.....</b>	<b>1-1</b>
<b>2.0 PROJECT MANAGEMENT.....</b>	<b>2-1</b>
2.1 PROJECT OBJECTIVE AND SCOPE OF WORK.....	2-1
2.2 DESCRIPTION OF CONTAMINANTS PRESENT.....	2-1
2.2 PROJECT TASK DESCRIPTIONS.....	2-1
2.3 PROJECT ORGANIZATION.....	2-2
2.4 DATA QUALITY OBJECTIVES FOR MEASUREMENT DATA.....	2-6
<b>3.0 SAMPLING.....</b>	<b>3-1</b>
3.1 SAMPLING METHODS AND PROCEDURES.....	3-1
3.2 SAMPLE IDENTIFICATION.....	3-2
3.3 SAMPLE PRESERVATION AND HOLDING TIMES.....	3-3
3.4 FIELD QC SAMPLES.....	3-3
3.5 DECONTAMINATION.....	3-4
3.6 CROSS-CONTAMINATION MINIMIZATION.....	3-5
3.7 SAMPLE LOG BOOK.....	3-6
3.8 SAMPLE LABELS.....	3-7
3.9 CUSTODY SEALS.....	3-7
3.10 CHAIN-OF-CUSTODY PROCEDURES.....	3-2
3.11 PACKAGING, HANDLING, AND SHIPMENT OF SAMPLES.....	3-3
<b>4.0 DATA ACQUISITION.....</b>	<b>4-1</b>
4.1 ANALYTICAL METHOD REQUIREMENTS.....	4-1
4.2 QUALITY CONTROL REQUIREMENTS.....	4-1
4.3 INSTRUMENT TESTING, INSPECTION, AND MAINTENANCE.....	4-1
4.4 INSTRUMENT CALIBRATION.....	4-1
<b>5.0 DATA MANAGEMENT.....</b>	<b>5-1</b>
5.1 LABORATORY DATA REDUCTION.....	5-1
5.2 LABORATORY DATA VALIDATION.....	5-1
5.3 PROJECT DATA REVIEW.....	5-3
5.4 DATA REPORTING.....	5-4
5.5 DATA STORAGE AND ARCHIVE.....	5-4
<b>6.0 DATA ASSESSMENT PROCEDURES.....</b>	<b>6-1</b>
6.1 ACCURACY.....	6-1
6.2 PRECISION.....	6-2
6.3 COMPLETENESS.....	6-3
6.4 CRITERIA FOR REJECTION OF OUTLYING MEASUREMENTS.....	6-3
6.5 METHOD DETECTION LIMITS AND PRACTICAL QUANTITATION LIMITS.....	6-3
6.6 LABORATORY AND FIELD CONTAMINATION.....	6-3
<b>7.0 PERFORMANCE AND SYSTEM AUDITS.....</b>	<b>7-1</b>
7.1 FIELD PERFORMANCE AUDITS.....	7-1
7.2 FIELD SYSTEM AUDITS.....	7-1
7.3 LABORATORY PERFORMANCE AUDIT.....	7-2
7.4 LABORATORY SYSTEM AUDITS.....	7-2

## ***TABLE OF CONTENTS***

---

<b>8.0 CORRECTIVE ACTION .....</b>	<b>8-1</b>
8.1 CORRECTIVE ACTION REPORT .....	8-2
8.2 QUALITY ASSURANCE REPORT.....	8-2

### **TABLES**

Table 2.1      Action Items

### **APPENDICES**

#### **APPENDIX A**

TABLE A-1 SAMPLING SUMMARY

TABLE A-2 PROJECT QUALITY CONTROL OBJECTIVES

#### **APPENDIX B**

CUSTODY SEAL

CHAIN-OF-CUSTODY LABEL

OHM SHIPPING LABEL

SHIPPING INSTRUCTIONS FOR SENDING SAMPLES TO THE LABORATORY

#### **APPENDIX C**

SOPs

QP-650          STANDARD ANALYTICAL DATA DELIVERABLE REQUIREMENTS

QP-618          BAILERS

## ***1.0 INTRODUCTION***

---

This Sampling and Analysis Plan (SAP) presents, in specific terms, the policies, organization, functions, and Quality Assurance/Quality Control (QA/QC) requirements designed to achieve the data quality goals for the analysis of groundwater at the 6 new recovery wells at the North and South Groundwater Treatment Plants in the Hadnot Point Industrial Area. This work will be performed under Delivery Order 0175 of Contract Number N62470-97-D-5000 for the Navy Atlantic Division (LANTDIV) at the Marine Corps Base, Camp Lejeune, North Carolina.

This SAP integrates the required components of a generic quality assurance project plan (QAPP) and a field sampling plan (FSP). This document shall be implemented by the Project Manager, Project QC Manager, Project Chemist, Field Chemist/Scientist, and Sample Technicians. Any field changes shall be approved by the Navy's Technical Representative (NTR), OHM Project Manager, and OHM Project Chemist. These changes shall be documented by the Field Chemist/Scientist and distributed to the appropriate persons as amendments to the SAP.



## **2.0 PROJECT MANAGEMENT**

---

### **2.1 PROJECT OBJECTIVE AND SCOPE OF WORK**

The scope of work for Delivery Orders No. 0175 for the Hadnot Point Industrial Area North and South Plants are:

- Install three extraction well at the North Plant and three extraction wells at the South Plant
- Abandon two wells at the North Plant
- Expand the OU1 recovery well networks for both the North and South Plants
- Develop and sample the extraction wells
- Startup the wells and maintain operation of both the North and South Treatment Plants

### **2.2 DESCRIPTION OF CONTAMINANTS PRESENT**

Site 78, constructed in the late 1930s, was the first developed area at MCB Camp Lejeune. It was comprised of approximately 75 buildings and facilities including maintenance shops, gas stations, administrative offices, commissaries, snack bars, warehouses, and storage yards. There is presently no known uncontrolled disposal of wastes related to the various industrial activities at the site. Due to the industrial nature of the site, many spills and leaks have occurred over the years. Most of these spills and leaks have consisted of petroleum-related products and solvents from underground storage tanks (USTs), drums and uncontained waste storage areas.

### **2.2 PROJECT TASK DESCRIPTIONS**

The following tasks will be performed in support of the remedial actions at the Hadnot Point Industrial Area North and South Plants at Marine Corps Base, Camp Lejeune, North Carolina:

- Site Preparation
- Utility Clearances
- Well and well vault installation
- Well abandonment
- Well development and startup
- Sample and analyze groundwater
- Validate the acquired data for usability determination

## 2.3 PROJECT ORGANIZATION

The project manager is the primary focal point for control of the project activities. The project manager will be supported by the QA Management team which will provide reviews, guidance, and technical advice on project execution issues. Members of this staff will be on an "as-needed" basis to assist in smooth project execution. The project manager will be supported by the project team consisting of a supervisory, health and safety, technical, and QA/QC staff to ensure that the project is safely executed in compliance with applicable laws, regulations, statutes, and industry codes. Individuals of the project team are responsible for fulfilling appropriate portions of the project QA program, in accordance with assignments made by the project manager. The project manager is responsible for satisfactory completion of the project QA program. Specific responsibilities may be assigned by the project manager to the deputy project manager and other members of the project staff. An organizational chart of the project team is presented in Work Plan.

The responsibilities of the key members in the project organization are:

### ***Project Manager - James A. Dunn, Jr., P.E.***

The project manager is responsible for the overall direction of this project executed under his supervision. He provides the managerial administrative skills to ensure that resource allocations, planning, execution, and reporting meet contract requirements. He is ultimately accountable for all work activities undertaken on this project. The global quality-related responsibilities of the project manager can include, but are not limited to, the following:

- Organization of the project staff and assignment of responsibilities.
- Understanding of contract and scope of work for a specific project.
- Communication to the project staff regarding client requirements and QA practices.
- Identification, documentation, and notification to the client and project staff and QA personnel of changes in the scope of work, project documentation and activities.
- Supervision of preparation and approval of project-specific procedures, work plans, and QA project plans.
- Approval of project design bases, design parameters, drawings, and reports.
- Approval of project remedial action/construction methodologies.
- Dissemination of project-related information from the client such as design bases, input parameters, and drawings.
- Liaison for communications with the client and subcontractors. Liaison between the project staff and other internal groups.

- Decision of whether or not drawings require independent review.
- Investigation of nonconformances, notification of QA personnel, and implementation of corrective actions.
- Determination of the effect of nonconformances on the project and the appropriateness for reporting such items to the client, and providing appropriate documentation for reporting.
- Determination that changes, revisions, and rework are subject to the same QC requirements as the original work.
- Serve as final reviewer prior to release of project information.
- Approve and sign outgoing correspondence.
- Custodian of all project related documents.

Some of these responsibilities may be assigned by the project manager to the Site Supervisor, who will remain on site throughout the project field activities.

***Site Supervisor – Randy Smith***

The site supervisor is responsible for the day-to-day management of this specific delivery order. He will ensure sufficient resource allocations to maintain project schedule and budget. He will provide daily feedback to the project manager on project progress, issues requiring resolution, etc. The quality-related responsibilities of the site supervisor include, but are not limited to, the following:

- Notification to the project manager if the project cannot be completed with regard to quality, schedule, or cost.
- Oversight and control of subcontractor services.
- Liaison for communications with OHM project staff and other internal groups as well as with the NTR and on-site inspector.
- Supervision of day-to-day site activities in accordance with project and program requirements.
- Preparing the Contractor Production Report.
- Preparing the Quality Control Reports.
- Initiating corrective actions for non-conformance identified on-site.

***Project Chemical QA Officer - Theresa D. Rojas***

The chemical QA officer is responsible for implementing the project chemical QA program. She is responsible for informing the project manager of any site-specific QA issues. Her responsibilities include, but is not limited to, the following:

- Reviewing subcontractor's QA Manuals and/or Laboratory Quality Management Plans (LQMPs) and if possible, performing audits on the labs.
- Certifying the level of QA that has been achieved during the generation of analytical data.
- Initiating and overseeing all audit functions.
- Stopping work if quality objectives are not being met.
- Initiating investigations for nonconformances, identifying appropriate corrective actions, and performing follow-up audits to ensure that the corrective actions were successful.

***Project Chemist – Terence A. Whitt***

The project chemist is responsible for implementing the project plans and ensuring that the quality assurance and data quality objectives are being met for the project. He is also responsible for informing the chemical QA officer of any site-specific problems and for coordinating QA efforts with the contracted laboratory. His specific responsibilities include, but are not limited to, the following:

- Determining if the project and data quality objectives are being met.
- Evaluating chemical data for technical validity and ensuring adherence to published guidelines.
- Analyzing and interpreting all subcontracted technical and laboratory results.
- Implementing QA/QC procedures.
- Assuring the continuity of chain-of-custody evidence
- Working with the QC engineer to compile and submit required QA Reports (QARs).
- Compiling, revising, updating, and submitting SAPs
- Implementing corrective actions as required by the QC engineer or chemical QC officer.
- Ongoing QA/QC training of new and current personnel.

- Reviewing laboratory invoices for completeness and accuracy.

***Laboratory Coordinator - Elena Rodriguez***

The laboratory coordinator is responsible for procuring a certified laboratory based on the requirements needed for the project. Her responsibilities include, but are not limited to, the following:

- Selection of qualified laboratories and control of laboratory services requests.
- Assist coordination of laboratory with field sample shipments.
- Management of laboratory data in conjunction with the project and field chemist.
- Liaison between the field and the laboratories when changes are required in the SAP and Purchase Orders.

***Field Chemist -Russell Henderson***

The field chemist will:

- Implement the SAP and designated QA/QC procedures.
- Oversee all field sampling activities.
- Report all QC data to the project chemist for review.
- Implement corrective actions as required by the project chemist.
- Perform on-site screening and analyses of samples, if needed.
- Fill out sample tracking forms and related analytical and QC forms and logbooks.
- Ensuring that the samples are handled, packaged, and shipped according to the SAP.
- Ensuring that the laboratory supplies the sample containers, shipping supplies, chain-of-custody records, and the required QC samples (i.e., trip blanks).

***Sample Technician - TBD***

The sample technician will be responsible for:

- Carrying out all sampling in accordance with approved procedures and methodologies as defined in the SAP.
- Generating field blanks, equipment rinsate blanks, and acquiring field duplicate samples as required by the SAP.

- Completing sampling logbooks, sampling forms, labels, custody seals, and chain-of-custody forms and other paperwork as required by the SAP.
- Packaging and Shipping of samples to appropriate laboratories.

## **2.4 DATA QUALITY OBJECTIVES FOR MEASUREMENT DATA**

Data generated from those tasks described in Section 2.2 will be used to assess the effectiveness of the treatment system, and to identify and assess the need for continued treatment or select other alternatives. Project specific quality objectives are listed in Appendix A, Table A-2. These include the quantitation, project action, accuracy, precision, and completeness limits by which the data will be evaluated.

A Naval Facilities Engineering Service Center (NFESC)-certified or US Army Corps of Engineers-Missouri River Division (USACE-MRD)-approved laboratory will be used for all sample analyses. The laboratory will also be North Carolina-approved. A copy of the laboratory's QA Manual, statement of qualifications, and appropriate certificates of approval are kept on file in OHM's Norcross office and are available upon request from the NTR, LANTDIV, or other regulatory agencies. A copy of the approved Sampling and Analysis Plan will be forwarded to the laboratory selected to perform chemical analysis of the samples.

All off-site samples will meet OHM's minimum requirement for the QA/QC as specified in OHM QP-650. A copy of OP-650 is included in Appendix D. If disposal analysis is required no duplicates or rinsate blanks will be collected. All sampling and analytical activities will be in accordance with federal, state, and local regulations. A summary of the field QC sampling requirements is shown in Table A-1 in Appendix A.

Data evaluation will be performed by the project chemist on all data before it is used. Third party data validation will not be performed on the final data. Data evaluation results will be provided in the project close-out report.

## 3.0 SAMPLING

---

### 3.1 SAMPLING METHODS AND PROCEDURES

The following sections describe sampling locations, frequencies, sample matrices, and measurements of parameters of interest. Table A-1 "Sampling Summary" in Appendix A presents a summary of these items.

#### 3.1.1 Gauging

Prior to the sampling event, each of the designated wells will be gauged for water levels. Wells to be gauged for the North Plant are: RW-11, RW-12, and RW-13. Wells to be gauged for the South Plant are: RW-14, RW-15, and RW-16.

The procedure for gauging the wells is outlined below. This procedure assumes a product layer is present. If a layer is not present disregard the product layer measurement.

- 1) Locate and uncap each well at the beginning of the task and let them equilibrate for at least 30 minutes.
- 2) Look for a mark at the top of the well casing (TOC) that indicates the measuring point. If no mark is found measure from the north side of the TOC.
- 3) Test the oil/water interface probe with the test button or switch on the unit (refer to the owners manual if needed).
- 4) Unreel the line slowly until the unit indicates that the probe has reached the product layer (signaled by a steady tone and light). See note 2.
- 5) Move the probe up and down to find the precise top level of the product. Record the level of the product to 1/100 of a foot. See note 3 .
- 6) Slowly lower the probe until the steady tone and light become intermittent. This indicates the aqueous (water) layer. To get the measurement of the bottom of the product layer, lower the probe below the product layer and then slowly raise it until the tone and light are steady. Always measure the bottom of the product layer by bringing the probe up to the layer. Measure the bottom of the product to 1/100 of a foot. Record readings.
- 7) If the depth of the well is not known, lower the probe to the bottom and measure to 1/10 of a foot. Record readings.
- 8) Reel in the probe cleaning the tape with a towel or clean rag. Stop a few feet before reaching the end of the tape and lift the probe and remaining tape from the well. Then place the probe and tape into a bucket of water and decontaminate
- 9) To calculate the well volume use the formula:  $Vol (gal) = 0.785 d^2h \cdot 7.48$  where diameter (d) and height (h) are in feet.

#### Notes:

- 1) If a potentiometric surface map is to be prepared, it will be necessary to correct for the depression of the water surface by overlying free product. If the product is #2 fuel oil or lighter, multiply the thickness of the free product layer by 0.80 (the assumed

- density of the free product layer). Add the result to the calculated elevation of the water surface as actually measured.
- 2) If the probe is allowed to "free fall" or if the tape is bent at a sharp angle, the signal wires in the tape can be damaged or destroyed.
  - 3) Some tapes are marked in eighths of an inch. These readings must be converted to 1/100 of a foot units.
  - 4) If the relative concentrations of contaminant or thicknesses of free product are known from previous work, it is a good practice to start with the least contaminated well and work toward the most contaminated. This will minimize possible cross contamination.

### **3.1.2 Groundwater Sampling and Analysis**

A sampling round will be conducted prior to system start-up to collect baseline information on groundwater quality. All wells will be purged with a minimum of three well volumes or until the pH, temperature and conductivity measurements are stabilized. Stabilization is defined as : temperature +/- 1<sup>0</sup>c, pH +/- 0.1 pH units and conductance +/- 5 percent. Purge water will be stored and disposed at the water treatment plants along with any sundry decontamination fluids. Samples will be collected with disposable Teflon bailers or decontaminated non-disposable bailers. The volatile samples will be collected first followed by the semivolatile samples. Standard Operating Procedure (SOP) QP-618 attached in Appendix D provides general information and procedures for collecting sample with a bailer.

Sampling equipment will be thoroughly decontaminated between samples using the procedures described in Section 3.5 or disposable sampling equipment will be used. Field sampling personnel will wear disposable sampling gloves during sampling and will change gloves between sample locations to minimize the potential for cross-contamination. Other PPE may be required for sampling per the site HASP. Contact with sample will be avoided to minimize the potential for cross-contamination.

### **3.1.3 Drilling Wastes Disposal**

During the construction of the wells, drilling wastes will be stored and sampled for disposal characteristic. To profile the soil for disposal, four grabs and one composite sample will be collected from the stored material. Clean sampling glove will be worn for all sampling. One 4-oz. and one 8-oz. sample will be collected for disposal characteristics. The 4-oz. jar will be completely filled with no headspace to reduce volatilization of the compounds.

## **3.2 SAMPLE IDENTIFICATION**

The samples collected on-site will be provided with a unique sample designation. The number will serve to identify the site, location, and specific sample identification number. The sample designation format will be as follows:

CLJ-XXX-NNN-DD

where:



CLJ = Camp Lejeune  
XXX= Delivery Order for the project (175)  
NNN = Sequential number starting at 001, including QC samples such as field blank, equipment blanks, duplicates etc.  
DD = Matrix identifier and QC identifier  
e.g. GW for Groundwater

Other representative designations may be used as needed based on field conditions.

If sample is a field QC sample, the following designations will be added as a suffix

FB - Field Blank (numbered sequentially such as FB01, FB02 etc)  
RB- Equipment Rinsate Blank ( numbered sequentially such as RB01, RB02 etc.)  
(Duplicates will not be identified to the laboratory)

Sample location information will be included in the sample description area of the COC. Sample sequential numbers are not to be duplicated. Duplicate samples will be sent to the off-site laboratory blind. The latest OHM COC has been designed so that the cross-reference of the duplicate to the original sample can be included on the last page of the COC that does not go to the laboratory.

### **3.3 SAMPLE PRESERVATION AND HOLDING TIMES**

Samples collected for off-site analyses will be sent to the laboratory within 24 hours after collection to ensure that the most reliable and accurate answers will be obtained as a result of the analysis. The holding time begins from the date and time of collection in the field.

All environmental and treatment system samples, except for aqueous samples for metals, will be preserved to a temperature of 4°C prior to shipment to the analytical laboratory, using ice or refrigeration. This temperature should be maintained during shipment by placing ice in leak-proof containers, and placing it above and below the sample containers. Other sample preservation requirements and holding times applicable to the sample matrix and analyses are listed in Appendix A, Table A-1.

### **3.4 FIELD QC SAMPLES**

The appropriate number of field QC samples, as specified in the NFESC, 1996 document will be collected during this project. These samples will include field blanks, equipment rinsate blanks and field duplicate samples. These samples will be collected at the following frequencies and analyzed for the parameters listed in Appendix A, Table A-1:

#### ***Field Blanks ( Ambient Blanks)***

Field blanks , sometimes referred to as ambient blanks, are samples of contaminant-free media ( reagent grade water) witch are prepared at the site and handled in the field in the same manner as all other field samples. Field blanks are collected during the course of field sampling and, to the extent possible, in the actual sampling locations. Field blanks are

collected by placing contaminant-free medium ( reagent grade water) in the same type of container as field sample. Field blanks are preserved and stored in the same manner as field samples. At a minimum, one field blank per contiguous site from each sampling event is collected and is analyzed for those interfering contaminants that could potentially be present in ambient air at the sampling site. Approximate number of field blank samples planned to be collected is presented in Appendix A, Table A-1.

#### ***Equipment Rinsate Blank***

Equipment rinsate blanks are the final analyte-free water rinse from equipment cleaning collected daily for each matrix sampled. An equipment rinsate blank is collected in the same type of sample containers, and in all other ways is handled in the same manner as other field samples. The equipment rinsate blank must be collected during the sampling event (after collection of at least one field sample) after the sampling equipment has been decontaminated and prior to collection of the next field sample.

All equipment that comes into contact with field samples must be decontaminated prior to use. The use of disposable equipment is acceptable, but does not obviate the requirement for decontamination prior to use, or the requirement for collection of equipment rinsate blanks. Equipment rinsate blanks for disposable equipment are collected by passing contaminant-free medium through or over the decontaminated equipment. One equipment rinsate blank is collected per day, per sampling event for each matrix sampled that day. Equipment rinsates are analyzed for the same parameters as the sample collected that day. Approximate number of equipment blank samples planned to be collected is presented in Table A-1, Appendix A.

#### ***Field Duplicate***

Duplicates for soil samples are collected, homogenized, and split. All samples except volatiles are homogenized and split. Volatiles are not mixed, but select segments of soil are taken from the length of the core and placed in 4 oz glass jars. The duplicates for water samples are collected simultaneously. Field duplicates must be collected at a frequency of one sample per day per matrix or 10% of the field samples per matrix. All the duplicates should be sent to the primary laboratory responsible for analysis, along with the samples. Approximate number of field duplicates planned to be collected are presented in Table A-1, Appendix A. Duplicates will be sent to the off-site laboratory blind.

#### ***Trip Blank***

Trip blanks are defined as samples which originate from analyte-free water taken from the laboratory to the sampling site and returned to the laboratory with the volatile samples. One trip blank should accompany each cooler containing aqueous and non-aqueous volatile samples, should be stored at the laboratory with the samples, and analyzed by the laboratory. Trip blanks are only analyzed for volatile organic compounds and may not be required for this project if disposal samples are not taken. Approximate number of trip blank samples planned to be analyzed is presented in Table A-1, Appendix A.

### **3.5 DECONTAMINATION**

All sampling equipment (hand augers, spoons, stainless steel/glass mixing bowls, etc.) will be decontaminated before sampling commences, between each sample location, and prior to

leaving the site. The procedures for decontamination of equipment according to NEESA 20.2-047B are as follows.

- Remove gross contamination by scraping or brushing.
- Clean with tap water and phosphate-free laboratory detergent (liquinox), using a stiff brush to remove all surface contaminants.
- Rinse thoroughly with tap water.
- Rinse with 1:1 nitric acid (HNO<sub>3</sub>) metals grade (only if samples are to be analyzed for metals).
- Rinse thoroughly with tap water.
- Rinse thoroughly with deionized/distilled water.
- Rinse twice with reagent grade isopropanol or methanol.
- Rinse thoroughly with organic-free water and allow to air dry. (Do not rinse with deionized/distilled water. If organic-free water is not available, allow equipment to air dry.)
- Wrap equipment with aluminum foil prior to storage or transportation to sample locations.

Decontamination fluids will be collected in properly labeled 55-gallon drums, and staged in a secure area until final disposal unless other arrangements are made.

### **3.6 CROSS-CONTAMINATION MINIMIZATION**

Cross-contamination is the introduction of contaminants into the sample through the sampling and/or sample-handling procedures. It can cause an otherwise representative sample to become non-representative. The most important means of minimizing cross-contamination are as follows:

- Sampling expendables, i.e., sample gloves, pipettes, string, dip jars, etc., must not be reused. Used expendables should be labeled so they are not confused with non-contaminated trash
- Minimum contact should be made between the sampler and the sample medium. For example, a sampler should not touch the sample during while loading the sample in the container.
- Sample collection activities should proceed progressively from the least contaminated area to the most contaminated area.
- Sampling equipment should be constructed of Teflon, stainless steel, or glass that has been properly precleaned for collecting samples. Equipment constructed of plastic or PVC should not be used to collect samples for trace organic analyses.
- Any tools used in sampling must be carefully decontaminated prior to first use and after each use.

- Activities that could contaminate samples are prohibited in the sample handling and preparation area. These activities and the possible contaminants include:

<i>Activity</i>	<i>Possible Contaminants</i>
Smoking	Poly Aromatic Hydrocarbons
Spraying for insects	Pesticides, oils, solvents
Spraying for weeds	Herbicides, oils, solvents
Refueling	BTEX, hydrocarbons
Painting and paint stripping	Solvents

### 3.7 SAMPLE LOG BOOK

It is necessary for the sampling crew to maintain daily field notes. Items that must be included are sampling protocol, any changes to the procedures, meetings, instructions, safety precautions, personnel protection, and activities pertaining to the samples. The person taking notes must be knowledgeable enough about these activities to know which details are important.

Repetition of information recorded in other permanent logs should be avoided, but enough should be recorded to present a clear and accurate picture of technical activities. At a later date, should a question arise concerning a specific event or a procedure used, it will be answered from these notes. The following information should be logged into the logbooks and/or database:

- Date and time of sampling
- Sample number, locations, type, matrices, volumes, sample ID and descriptions, type and number of sample containers, names and signatures of individuals performing sampling tasks, Chain-Of-Custody (COC) and air bill numbers, preservatives, and date samples were sent
- Name of laboratories and contacts to which the samples were sent, turn around time (TAT) requested, and data results, when possible
- Termination of a sample point or parameter and reasons
- Unusual appearance or odor of a sample
- Measurements, volume of flow, temperature, and weather conditions
- Additional samples and reasons for collecting them
- Levels of protection used ( with justification)
- Meetings and telephone conversations held with LANTDIV, NTR, regulatory agencies, project manager, or supervisor

- Details concerning any samples split with another agency
- Details of QC samples collected

These notes must be dated and signed (each page) for validity. All logbooks will be bound and pre-numbered. All log book entries will be made with indelible ink and legibly written. The language will be factual and objective. No erasures will be permitted. If an incorrect entry is made, the error will be crossed out with a single strike mark, initialed, and dated. When audits are performed, the auditor's remarks and decisions must also appear in these notes. These audits should be followed up by written report submitted by the auditor, including opinions and conclusions. A copy of this report should be placed in the project file and one copy kept in the sampling file for easy reference. This information will also be entered in to the data base program that been prepared for the site. It will be entered daily by the field chemist or sample technician. This person will be the point of contact for all sampling and analytical information. Report outputs from the database is an acceptable substitute for the sample logbook.

### **3.8 SAMPLE LABELS**

Any samples placed into a sample container will be identified by a sample label. Sample label will identify the following information:

- PROJECT NUMBER
- DATE- Month, day, year
- TIME- Military time
- SAMPLE NUMBER- See Section 3.2 for designations
- SAMPLE DESCRIPTION
- SAMPLER- Sampler's name
- PRESERVATIVES
- ANALYSIS REQUIRED- See Appendix A, Tables A-1

The information described above should be printed neatly using an indelible marker. After the sample is taken and the label is securely attached, the sample is logged into the sample log book. An example of a sample label is presented in Appendix B.

### **3.9 CUSTODY SEALS**

Custody seals are narrow strips of adhesive tape of glass fiber used to demonstrate that no tampering has occurred. They may be used on sampling equipment, sample transport containers, and individual sample containers. They should be signed and dated by the sampler and placed from one side, across the top, and to the other side of the sample container or across the openings of the sample transport containers. An example custody seal is presented in Appendix B.

### 3.10 CHAIN-OF-CUSTODY PROCEDURES

In order to generate legally defensible data of the samples collected throughout the project, the possession of samples must be traceable from the time the samples are collected until they are introduced as evidence in legal proceedings. To maintain and document sample possession, chain-of-custody procedures are followed as described below:

A sample is under your custody if:

- It is in your actual possession, or
- It is in your view, after being in your physical possession, or
- It was in your physical possession and then you locked it up to prevent tampering, or
- It is in a designated secure area

An example of a COC form is presented in Appendix B. The following information is required on the COC:

- Project Name
- Project Location- City and State in which the project site is located
- Project Number
- Project Contact-OHM employee responsible for overseeing the sampling operation. This person should be the individual to whom questions are to be directed or verbal results are given ( Project Manager, Site supervisor, or Project Chemist)
- Site Telephone Number- The telephone number of on-site office trailer or number where person responsible for samples can be contacted.
- Sample Date-Month, Day, Year
- Sample Time- Military time
- Sample Identification- Sample number and location
- Sample Type-Designation of sample as grab or composite
- Sample Description- Sample matrix, and a brief description of the sampling location
- Sample Preservation- Preservatives used
- Analytical Parameters Requested -- Analytical parameter, method numbers, and specific compounds of interest, if applicable.
- Air bill Number
- Laboratory -- Laboratory where samples are to be sent
- Laboratory Phone -- Telephone number of laboratory
- Laboratory Contact -- Contact person for laboratory
- Relinquished By -- Signature of sender (OHM)
- Date Relinquished -- Date samples were relinquished
- Accepted By -- Signature of acceptor
- Date Received -- Date samples were accepted
- Turnaround Time -- Turnaround times requested or date the results are required from the lab
- Sampler's Signature -- Signature of sampler

The COC will be sealed in a ziploc bag and taped in place on the underside of the top of the sample transport container (cooler).

### **3.11 PACKAGING, HANDLING, AND SHIPMENT OF SAMPLES**

Samples will be packaged as to minimize shifting of the samples during shipment. An absorbent, such as vermiculite or kitty litter, will be placed at the bottom of the shipment container in order to absorb any liquids in the event of sample breakage. All samples will be individually placed into appropriately sized ziploc bags and sealed.

Samples, which must be kept at 4°C, will be shipped on ice in insulated containers. Ice will be placed in a container such as a ziploc bag and sealed so that water will not fill the shipping container as the ice melts. The ice will be double bagged to insure the ice does not leak. Aqueous samples for metals analysis, except hexavalent chromium, shall not be shipped or stored under refrigeration.

Samples will be shipped via an overnight shipping agency to the appropriate laboratory. IATA regulations will be followed as they are more applicable to OHM's method of sample shipment. Instructions for filling out shipment documentation are included in Appendix B. These instructions are for shipping samples with unknown or limited hazards. All information will be entered as directed. No changes or substitutions to these instruction will be made irrespective of their significance. A copy of the OHM sample shipping label is included in Appendix B.

## **4.0 DATA ACQUISITION**

---

### **4.1 ANALYTICAL METHOD REQUIREMENTS**

Analytical requirements for this project are listed in Appendix A, Table A-1. All samples will be analyzed according to USEPA SW-846 Test Methods for Evaluating Solid Waste, Physical/Chemical Methods whenever possible. Alternative methods of analysis from other sources (EPA, ASTM, NIOSH, Standard Methods, etc.) may also be used.

### **4.2 QUALITY CONTROL REQUIREMENTS**

Project Quality Control (QC) requirements for precision, accuracy, completeness, and quantitation limits are listed in Appendix A, Table A-2. QC procedures and acceptance limits must be met as specified in the individual methods. In addition, the laboratory must meet the specification and requirements as described in the NFESC, 1996 document.

### **4.3 INSTRUMENT TESTING, INSPECTION, AND MAINTENANCE**

Proper maintenance is critical to the performance of minimization of downtime of all equipment, whether it be for measurement or support. Inspection will be performed, at a minimum, prior to use of the instruments. Preventive maintenance will be performed as recommended by the manufacturer of the respective equipment. All routine maintenance and major repairs performed on field screening or analytical equipment will be recorded in bound maintenance logbooks that have been specifically designated for that instrument. Equipment that fails calibration or becomes inoperable during use will be removed from service and segregated to prevent inadvertent use, or will be tagged to indicate that it is out of calibration. Such equipment will be repaired and recalibrated or completely replaced.

### **4.4 INSTRUMENT CALIBRATION**

All calibrations on field instruments will be performed, as a minimum, on a daily basis. Every calibration will be recorded in the maintenance logbook for each instrument. Quality control check standards from a separate source will be used to check initial calibration, and acceptance and rejection criteria.

Monitoring instruments, such as the OVA or FID, O<sub>2</sub>/LEL meter, Monitox, etc. will be calibrated as specified in the HASP. Off-site analytical instruments will be calibrated according to the method specifications and the laboratory's QA Manual.



## **5.0 DATA MANAGEMENT**

---

Data management is the system by which data is reduced, reviewed, validated, reported, distributed, and finally archived. The criteria in this system are designed to meet the project objectives.

### **5.1 LABORATORY DATA REDUCTION**

Data reduction includes the identifications and calculations necessary to convert the raw instrument readings to the final reported compounds and their respective concentrations.

#### ***Responsibilities of Analyst***

Each analyst is responsible for converting raw data into reportable values. These specific duties include:

- Proper identification of the analyte
- Generation of calculations
- Checking associated calibrations to ensure support of data
- Associated QA/QC checks are supportive of data
- Associated documentation is complete and accurate in respective log books
- Associated chromatograms and strip chart recordings are labeled with data, instrument number, run parameters and analyst

### **5.2 LABORATORY DATA VALIDATION**

All data generated for the project within the laboratory will be extensively checked for accuracy and completeness. The data validation process consists of data generation, reduction, and three levels of review.

The analyst who generates the raw data has the prime responsibility for the correctness and completeness of the data. All data generated and reduced will follow protocols specified in the laboratory SOP. Each analyst reviews the quality of his work based on an established set of guidelines. The guidelines are:

- Sample preparation information is correct and complete
- Analysis information is correct and complete
- The appropriate Standard Operating Procedures have been followed

- Analytical results are correct and complete
- Analysis is performed within prescribed holding times.
- QC sample results are within established control limits
- Blank sample results are within appropriate QC limits
- Special sample preparation and analytical requirements have been met
- Documentation is complete
- The next level of review is performed by the section supervisor or data review specialist. The review is structured to ensure that:
  - Calibration data are scientifically sound, appropriate to method, and completely documented.
  - QC results are within established limits.
  - Reporting units are consistent with the method and the matrix.
  - Quantitative results are correct.
  - Data results are consistent with information on the COC.
  - Documentation is complete.
  - The data is ready for incorporation into a final report.
  - The data package is complete and ready for data archive.

The second level of review is structured to ensure all calibration data and QC sample results are reviewed and all of the analytical results from 10 percent of the samples are checked back to the bench sheet. If no problems are found with the data package, the review is complete. If problems exist, an additional 10 percent is reviewed, the process continues until no errors are found or the package has been reviewed in its entirety.

The final level of review by the laboratory comes from the program administrator or laboratory QA Officer. He/she reviews the report to ensure that the data meets the overall objectives of the project.

Once the data has been validated, it is ready for report production. The report will contain:

- Description of sample types

- Tests performed, problems encountered during testing
- Dates sampled
- Date received
- Date extracted
- Date analyzed
- Analytical results
- Reportable limits
- QC information: percent recovery, relative percent difference, control limits, blanks analyses, matrix spikes, and other additional special QC information
- Qualifiers for data falling outside of QC limits
- Methodology
- Name of the analyst
- Signature of laboratory representative
- Dual column confirmation results
- Calibrations (when requested)
- Instrument performance checks (when requested)
- QC Batch number

The report from the laboratory will be paginated and will also include a copy of the original COC for the samples analyzed.

### **5.3 PROJECT DATA REVIEW**

#### ***Project Chemist Data Review Responsibilities***

The project chemist is responsible for initial review of the data from the laboratory. This review includes:

- Verifying that all requested data are reported
- Verifying that samples are analyzed according to the contract specified method

- Verifying that all analytes requested are reported
- Verifying that holding times are not exceeded
- Verifying that matrix spike, matrix spike duplicate, and surrogate recoveries fall within the laboratory's acceptance criteria
- Reviewing blank data for contamination
- Reviewing field quality control results for inconsistencies
- Verifying that the data generated meet the project Data Quality Objectives specified in the SAP.

The project chemist is responsible for informing the Project Manager and Project Chemical QA/QC Officer of any laboratory and/or sampling deficiencies or issues. These issues and subsequent decisions will be documented on the data evaluation report produced by the Project Chemist for each data package.

***Project QC Engineer Data Review Responsibilities***

The Project QC Engineer is responsible for interfacing with the project chemist, project manager, and the laboratory's QA Officer to resolve any QA/QC issues affecting the data. He/she is also responsible for finalizing any QA/QC issues with the laboratory and/or the project chemist. This includes obtaining a corrective action from the parties involved.

**5.4 DATA REPORTING**

The preliminary data will be faxed to the project chemist. This data may or may not have undergone the full laboratory review process and may contain errors and discrepancies. Prior to the use of data results for any decisions, the data will be reviewed by the project chemist and assessed against the project goals and data quality objectives. A copy of the preliminary data, including review comments from the project chemist will be submitted to the site and/or the project manager.

The hard and final copy data will be evaluated by the project chemist and assessed against the preliminary data, project goals and data quality objectives. Any errors, discrepancies, and nonconformances will be brought to the laboratory's and project manager's attention.

When QA issues have been satisfactorily settled and data evaluation has been completed, the project manager may release the data to the client and/or regulating agencies.

**5.5 DATA STORAGE AND ARCHIVE**

After OHM has completed its work for the project, all documents generated will be assembled in the project file. Individuals may retain clean (no handwritten comments) copies of documents for their personal files but only after personally verifying that the original or

similar copy is in the project file. The project manager/supervisor is responsible for ensuring the collection, assembly, and inventory of all documents relative to the project at the time the objectives are met. The file then becomes accountable. Any records leaving the file must be signed out.

When a contractor has completed the project objectives, all file documents are reviewed and submitted to the central file. The project file contains the following document classes:

- Project logbooks
- Drum logs and other forms
- Sample identification documents
- Chain-of-custody records
- Analytical logbooks, laboratory data, calculations, graphs, etc.
- Correspondence
  - Inter-office
  - Client
  - Regulating agencies
  - Record of confidential material
- Report notes, calculations, drafts
- References, literature
- Sample (on-hand) inventory
- Check-out logs
- Litigation documents
- Miscellaneous – photographs, maps, drawings, etc.

Once deposited in the file, documents must be checked out. The final report is usually generated by use of computer. A back-up copy of the report on diskette is filed along with the project file. The original report remains in the hard drive of the computer until such a time is required to download it on a diskette. This diskette is also archived. All information under the corresponding project number is maintained in the archive system for five years. All archives are accessed by the archives file master list which is maintained in a separate location from the archives.

## **6.0 DATA ASSESSMENT PROCEDURES**

---

Reliability in analytical determination is maintained through strict adherence to quality control procedures. Procedures are designed to control both the accuracy and precision of analytical results. For the validation of the data, a known method spike is routinely analyzed to ensure the accuracy of results. The procedure is to run the standard QA/QC and sample analysis with each lot of samples sent to the laboratory. If more than ten individual analyses are made, additional standards will be analyzed at a rate of one standard per ten analyses. Some procedures call for the use of either a surrogate spike or the standard addition of a known quantity of the analyte to a split of the sample being analyzed.

Control charts will be prepared using an estimate of the spike recovery obtained from the literature or determined by repeated analyses run in the laboratory. Each time the analyst runs a method spike, the results is entered on the control table. If a standard addition technique is used, a plot of instrument response versus added analyte concentration is made in order to determine analyte concentration in the original sample. These are further explained in the laboratory's QAM.

Replicate analyses will be performed on at least 10 percent of the samples processed by the laboratory. A record of the precision of most analyses is kept by calculating and plotting the industrial statistic I (which is equivalent to the coefficient of variation). Blanks are also run with each batch of samples or individual sample analyzed regardless of the level of certification of the data.

The purpose of spikes, blanks, and replicates is to provide a sound scientific basis from which the degree of certification of the resultant data can be objectively concluded. These are not management decisions, but follow naturally from the results of the above QC procedures.

### **6.1 ACCURACY**

Data accuracy is a reflection of the efficiency of the analytical procedure. It is determined by use of spiked samples and standard reference materials or laboratory control samples performed at the rate of one set every 20 samples. A control chart is generated using historical laboratory data where warning and control limits are established to assess data accuracy.

The accuracy (check standards) samples will have concentration values of the mid-standard. During analysis, a minimum of 10 percent of samples are accuracy samples. The accuracy samples are staggered through the analysis, not placed one after another. After a minimum of seven accuracy samples are analyzed, the percent recovery is calculated for each sample.

The accuracy criteria is determined by calculating the standard deviation of seven or more percent recovery values and setting the upper and lower control limits using the following equations:

Upper control limit =  $p + 3 \text{ SD}$   
Lower control limit =  $p - 3 \text{ SD}$

Where:

p = Average percent recovery

SD = Standard deviation

After the standard deviation, for the seven or more samples has been calculated, the accuracy control limits are generated and are then used to determine if the analysis is out of control. This is done by checking the results against the control limits. If any values are above the upper control limit or below the lower control limit, all sample results after the last qualifying accuracy sample must be repeated or discarded. If seven consecutive values fall below the lower control limit, new limits are calculated using the new accuracy check values. If the values fall between the upper and lower limits, then conditions are reported as "within limits."

### **6.1.1 Recovery Control**

Recovery control is necessary to determine if the sample matrix is interfering with the constituent being analyzed. A minimum 5 percent of samples will be recovery check samples (matrix spikes). Samples involving different types of matrices will have at least one recovery check sample for each matrix.

Control limits will be determined for each matrix, determining the deviation for seven or more percent recovery values.

## **6.2 PRECISION**

Duplicate and replicate samples analyzed by the laboratory assess the precision of the sampling effort. Control limits for duplicate/replicate Relative Percent Difference (RPD)s are listed in Appendix A, Table A-2. Once a sufficient amount of replicate data becomes available, field precision control charts are constructed similar to the laboratory precision charts. For any given concentration, the mean and the standard deviation(s) of the replicates are calculated. Data from each sample set are pooled with the previous sample sets to generate control and warning limits for the next set. Control and warning limits for water samples are set at  $\pm 2s$  and  $\pm 3s$ , respectively. Control limits for solid samples are more liberally established due to matrix heterogeneity. Data outside any control limit are subject to QA review.

Precision is based upon the results of the RPDs as calculated from the percent recoveries of the matrix spike and duplicate samples. The control limits for precision is based on historical laboratory data.

MS and MSD samples on a per batch or a minimum frequency of 5 percent are analyzed to assess precision. Duplicate results are compared and the RPD is then determined. The RPD will be entered into the laboratory's data system and will be used to define the precision of the analysis. Minimum limits are listed in Appendix A, Table A-2.

### **6.3 COMPLETENESS**

The field supervisor must ensure all sites are sampled for all the specified analyses, that sufficient sample volume has been provided to complete those analyses, and that all of the QA samples have been included with each sample set. The goal for completeness for each sample set shipped to the laboratory is 100 percent. Minimum limits are listed in Appendix A, Table A-2.

Completeness is expressed as the percentage of the amount of valid data obtained to the amount of data expected. For a set of data to be considered complete, it must include all QC data verifying its accuracy and precision.

If samples analyzed do not meet all QC requirements in terms of accuracy and precision for any specific parameter, the sample preparation and analysis will be repeated pending adequate volume.

### **6.4 CRITERIA FOR REJECTION OF OUTLYING MEASUREMENTS**

There are many statistical tests for rejection of outlying data points obtained from a set of measurements from a single population. A test recommended in "Statistical Manual of the Associate of Official Analytical Chemists," 2nd Edition, W. J. Youden and E. H. Steiner, 1975, pg. 86, is the Dixon Test. This test is not dependent on the distribution of the data and can be used for as few as three measurements. A more complete description for this broadly applicable test can be found in the referenced text.

Another reference is the USEPA National Functional Guidelines for Data Validation of Organics and Inorganics. Also, specific programs may have quality objectives with criteria for rejection of outlying measurements.

### **6.5 METHOD DETECTION LIMITS AND PRACTICAL QUANTITATION LIMITS**

Method detection limits (MDLs) must be established by the laboratory. This should, at a minimum, be established on a yearly basis. MDL is the minimum concentration of a substance that can be identified, measured, and reported with 99% confidence that the analyte concentration is greater than zero.

Practical quantitation limit (PQL) is the lowest level that can be reliably determined within specified limits of precision and accuracy during routine laboratory operating conditions. The PQLs are generally 5-10 times the MDL. The PQL is the most applicable limit of reporting for this program.

### **6.6 LABORATORY AND FIELD CONTAMINATION**

It is not unusual to find the following analytes at trace levels in the samples:

- Methylene chloride



- Acetone
- Freon (1,1,2-trichlorotrifluoroethane)
- Bis(2-ethylhexyl)phthalate
- Hexane
- Isopropanol
- 2-Butanone

These are common solvents used in the field and in the laboratory.

In order to fully evaluate data containing trace levels of these contaminants, one must have data from trip blanks, field blanks, equipment blanks, and all applicable laboratory blanks for that batch of samples.

The determination on the use of the data will be made during the Data Validation process.

## **7.0 PERFORMANCE AND SYSTEM AUDITS**

---

Audit is defined as systematic check to determine the quality of operation of field and laboratory activities. It is comprised of the following:

- Performance audit
- System audits

These include a detailed review of each operating component of the network. Auditing will ultimately assist in determining if each element within a system is functioning appropriately per the QA program requirements.

### **7.1 FIELD PERFORMANCE AUDITS**

Field performance audits are performed on an ongoing basis during the project as field data is generated, reduced, and analyzed. All numerical analyses, including manual calculations are documented. All records of numerical analysis are legible, of reproduction quality, and supporting to complete permit logical reconstruction by a qualified individual other than the originator.

Other indicators of the level of field performance are the analytical results of the blank, duplicate, and replicate samples. Each blank analysis is an indirect audit of effectiveness of measures taken in the field to ensure sample integrity. The results of the field duplicate and replicate analysis is an indirect audit of the ability of each field team to collect representative sample portions of each matrix type.

### **7.2 FIELD SYSTEM AUDITS**

System audits of site activities are accomplished by an inspection of all field activities by the Project Chemical QC Officer. This audit is composed of comparisons between current field practices and standard procedures. The following is a list of criteria to be used in the evaluation of field activities:

- Overall level of organization and professionalism
- All activities conducted in accordance with work plan
- All procedures and analyses conducted according to procedures outlined in this document
- Sample collection techniques versus the site sampling and analysis plan
- Level of activity and sample documentation

- Working order of instruments and equipment
- Level of QC conducted by each field team
- Contingency plans in case of equipment failure or other event preventing the planned activity from proceeding
- Decontamination procedures
- Level of efficiency which each team conducts planned activities at the site
- Sample packaging and shipment

After the audit, any deficiencies are discussed with the field staff, and corrections are identified. If any of these deficiencies might affect the integrity of the samples being collected, the QA Officer informs the field staff immediately, so corrections can be made. The field performance audit will be conducted at the start of the project, one before the end of the project, and as directed by the project manager. OHM will also submit to all requests by regulatory agencies, or other clients for external field systems audits.

### **7.3 LABORATORY PERFORMANCE AUDIT**

The laboratory performance audit verifies the ability of the laboratory to correctly identify and quantitate compounds in blind check samples submitted by an auditing agency. If the laboratory participates in Performance Evaluation (PE) programs such as USEPA WS/WP studies, AIHA, PAT studies, etc., results from these studies will be generally acceptable by OHM. However, during the course of the project, it may be necessary for the Project QA/QC Officer to send PE samples to the laboratory to evaluate specific parameters.

The contracted laboratories will undergo performance audits throughout the project consisting of field QC samples. Occasionally PE samples will be supplied by the client or external organizations which will be spiked with the same analytical parameters that are being investigated on site. External laboratory performance audits by auditing agencies such as the USEPA, USACE-MRD, DOD, NFESC, etc., are not routinely scheduled. However OHM and its subcontracted laboratories will submit to any external audit upon request by the USEPA or the client.

### **7.4 LABORATORY SYSTEM AUDITS**

The laboratory system audit is a review of analytical laboratory operations to verify that the facility has the necessary equipment, staff, and procedures in place to generate acceptable data. It is also to determine that each element within an activity is functioning appropriately and within the guidelines of applicable methodology, approved procedures, and the site QAPP. An on-site inspection is routinely performed by the laboratory's QA Manager and may also be frequently performed by the OHM Project Chemical QA/QC Officer. If the laboratory participates in certification programs, audits performed by the certifying agencies may satisfy the criteria of systems audits for the project.

If the laboratory is in question, a system audit can be directed by the client and performed by OHM or the client's representative. Any recommendations made will be considered for implementation and any corrective actions will be taken to correct any deficiencies found. Project-specific audit reports will be placed in the project files and laboratory audit reports will be kept by the laboratory for future reference.

## **8.0 CORRECTIVE ACTION**

---

This Corrective actions may be necessary as a result of the following QA activities:

- Field and laboratory performance audits
- Field and laboratory system audits
- Inter-laboratory comparison studies
- Calibration data fall out of specified limits
- Failure to adhere to the CQMP
- Failure to adhere to the site
- Failure to adhere to standard operating procedures and methods
- Data completeness below required limits
- Control limits are exceeded for QC samples

If, during system and performance audits, deficiencies or problems are discovered, corrective action will be initiated immediately. The appropriate field and laboratory personnel will be notified immediately and an investigative process will be implemented immediately to find solutions to these issues. The investigative process will consist, but is not limited to, the following:

- Determining when the problem occurred
- Determining which systems were affected by the problem
- Determining the cause of the problem
- Determining a corrective action to eliminate the problem
- Assigning the responsibility for implementing the corrective action
- Implementing the corrective action
- Evaluating the effectiveness of the corrective action
- Investigating alternative corrective actions if the original action was not sufficient in eliminating the problem

- Documenting that the corrective action has eliminated the problem

The Project Chemical QC Officer has the authority to require that all site activities threatened by the problem be stopped or limited until the corrective action has been implemented and satisfactorily verified to eliminate the problem.

Corrective actions may include, but is not limited to:

- Modifications to procedures
- Recalibration of instruments
- Replacement of solvents, reagents, and/or standards
- Additional training of personnel
- Reassignment of personnel

## **8.1 CORRECTIVE ACTION REPORT**

A Corrective Action Report (CAR) is necessary documentation of the investigative process. Depending on the issues, the CAR may be generated by the laboratory or the field personnel. Copies of the CAR will be given to the Project QC Officer and Project Manager, who will distribute it to the client. A copy of the CAR will be placed in the project files for future reference.

The CAR should include, but is not limited to:

- A description of the problem, deficiency, or issue
- Proposed resolutions
- Resulting actions
- Effectiveness of the resolutions
- Personnel responsible for implementation of the corrective actions
- Personnel responsible for monitoring the effectiveness of the actions.

## **8.2 QUALITY ASSURANCE REPORT**

The Project Manager, Project QC Officer, and Project Chemist will converse on a regular basis to review possible and potential problem areas and to ensure that all QA/QC procedures are being carried out. It is important that all data abnormalities be investigated to ensure that

they are not a result of operator or instrument deviation but are a true reflection of the methodology or task function. The project final report will contain a separate section that covers the data quality and validity. At a minimum, the following information will be included in the report:

- Assessment of measurement data precision, accuracy, and completeness
- System and performance audit results
- Significant QA problems and corrective actions implemented
- Copies of documentation such as memos, reports, etc.

The Project QC Officer will be responsible for preparing this report weekly or daily, as well as monthly written QA reports to OHM QA management. The Regional QA/QC Director will be responsible for reviewing and approving these monthly reports. Verbal reports will be made on a more frequent basis. All reports will be made available to the Project Manager, client, and regulating agencies. If no project audits were performed and no significant QA/QC problems occurred, a letter stating these facts will be submitted to the referenced parties in lieu of a QA Report.

**APPENDIX A**

**TABLE A-1 SAMPLING SUMMARY**  
**TABLE A-2 PROJECT QUALITY CONTROL OBJECTIVES**



**TAB A-1  
SAMPLING SUMMARY**

Sample Task	Sample Point	Matrix	Sampling Frequency	Approx Sample No	Sampling Method	Sampling Equipment	TAT <sup>1</sup>	QC Level	Required Analysis	Analytical Method	Holding Time	Preservatives	Containers
<b>BASELINE SAMPLING</b>													
Baseline Sampling	6 Wells	Water	Once	6 + 1 duplicate	Grab	Bailers	14 Days	OHM Maximum Deliverables;	Volatiles (Halocarbons)	601	14 days	Cool to 4 °C	2 ea 40 ml Amber Vials 0.008% Na <sub>2</sub> SO <sub>3</sub> if Cl present
									Volatiles (Aromatics)	602	14 days	Cool to 4 °C; HCl pH <2	2 ea 40 ml Amber Vials 0.008% Na <sub>2</sub> SO <sub>3</sub> if Cl present
	Trip Blank	Water	One per shipping container containing volatile samples	3	Prepped by Laboratory	Prepped by Laboratory	14 Days	OHM Maximum Deliverables;	Volatiles (Halocarbons)	601	14 days	Cool to 4 °C	2 ea 40 ml Amber Vials 0.008% Na <sub>2</sub> SO <sub>3</sub> if Cl present
	Trip Blank	Water	One per shipping container containing volatile samples	3	Prepped by Laboratory	Prepped by Laboratory	14 Days	OHM Maximum Deliverables;	Volatiles (Aromatics)	602	14 days	Cool to 4 °C; HCl pH <2	2 ea 40 ml Amber Vials 0.008% Na <sub>2</sub> SO <sub>3</sub> if Cl present
<b>DISPOSAL SAMPLING</b>													
Drilling Wastes	Composite of Wastes	Soils/mud	1 per waste stream	1	Composite 5 random grabs into 1 sample	SS spoon/bowls	14 Days	OHM Minimum Deliverables;	TCLP Volatiles	1311/8260B	14 day TCLP extr; 14 day analysis	Cool to 4°C	1 ea 4 oz amber glass
									TCLP Semi-Volatiles	1311/8270C	14 day TCLP extr; 7 day extr; 40 day analysis		
									TCLP Pesticides	1311/8081B	14 day TCLP extr; 7 day extr; 40 day analysis		
									TCLP Herbicides	1311/8151	14 day TCLP extr; 7 day extr; 40 day analysis		
									TCLP Metals	1311/6010A 7470	6 month TCLP extr; 6 month analysis Hg: 28 day TCLP extr; 28 day analysis		
									Reactivity	Chapter 7.3	None		
									Corrosivity	9045b	None		
									Ignitability	1010/1020A	None		

**TABLE A-2**  
**PROJECT QUALITY CONTROL OBJECTIVES**

Method No	Analyte / Component	Project Action Limits	Minimum PQL	Accuracy Limits	Precision Limits	Accuracy Limits	Precision Limits	Completeness Limits
		TCLP	TCLP	MS/MSD Recoveries	MS/MSD Deviation	LCS Recoveries	Field Dup Deviation	TCLP
<b>TCLP Volatiles</b>		(mg/L)	(mg/L)	(%)	(%)	(%)	(%)	(%)
8260B	1,1-Dichloroethylene	0.7	0.1	50-150	<50	70-130	<50	95
8260B	1,2-Dichloroethane	0.5	0.1	50-150	<50	70-130	<50	95
8260B	Benzene	0.5	0.1	50-150	<50	70-130	<50	95
8260B	Carbon Tetrachloride	0.5	0.1	50-150	<50	70-130	<50	95
8260B	Chlorobenzene	100	20	50-150	<50	70-130	<50	95
8260B	Chloroform	6	1	50-150	<50	70-130	<50	95
8260B	Methyl Ethyl Ketone	200	20	50-150	<50	70-130	<50	95
8260B	Tetrachloroethylene	0.7	0.7	50-150	<50	70-130	<50	95
8260B	Trichloroethylene	0.5	0.1	50-150	<50	70-130	<50	95
8260B	Vinyl Chloride	0.2	0.05	50-150	<50	70-130	<50	95
<b>TCLP Semi-Volatiles</b>		(mg/L)	(mg/L)	(%)	(%)	(%)	(%)	(%)
8270C	1,4-Dichlorobenzene	7.5	1	50-150	<50	70-130	<50	95
8270C	2,4,5-Trichlorophenol	400	80	50-150	<50	70-130	<50	95
8270C	2,4,6-Trichlorophenol	2	0.4	50-150	<50	70-130	<50	95
8270C	2,4-Dinitrotoluene	0.13	0.02	50-150	<50	70-130	<50	95
8270C	Cresol	200	40	50-150	<50	70-130	<50	95
8270C	Hexachlorobenzene	0.13	0.02	50-150	<50	70-130	<50	95
8270C	Hexachloroethane	3	0.5	50-150	<50	70-130	<50	95
8270C	Hexachlorobutadiene	0.5	0.4	50-150	<50	70-130	<50	95
8270C	Nitrobenzene	2	0.4	50-150	<50	70-130	<50	95
8270C	Pentachlorophenol	100	80	50-150	<50	70-130	<50	95
8270C	Pyridine	5	1	50-150	<50	70-130	<50	95
<b>TCLP Pesticides</b>		(mg/L)	(mg/L)	(%)	(%)	(%)	(%)	(%)
8081A	Endrin	0.02	0.004	50-150	<50	70-130	<50	95
8081A	Lindane	0.4	0.08	50-150	<50	70-130	<50	95
8081A	Methoxychlor	10	1	50-150	<50	70-130	<50	95
8081A	Toxaphene	0.5	0.1	50-150	<50	70-130	<50	95
8081A	Chlordane	0.03	0.005	50-150	<50	70-130	<50	95
8081A	Heptachlor and its Hydroxide	0.008	0.001	50-150	<50	70-130	<50	95

**TABLE A-2**  
**PROJECT QUALITY CONTROL OBJECTIVES**

		Project Action Limits	Minimum PQL	Accuracy Limits MS/MSD Recoveries	Precision Limits MS/MSD Deviation	Accuracy Limits LCS Recoveries	Precision Limits Field Dup Deviation	Completeness Limits
Method No	Analyte / Component	TCLP	TCLP	TCLP	TCLP	TCLP	TCLP	TCLP
<b>TCLP Herbicides</b>		(mg/L)	(mg/L)	(%)	(%)	(%)	(%)	(%)
8151A	2,4-D	10	2	50-150	<50	70-130	<50	95
8151A	2,4,5-TP	1	0.2	50-150	<50	70-130	<50	95
<b>TCLP Metals</b>		(mg/L)	(mg/L)	(%)	(%)	(%)	(%)	(%)
6010B	Arsenic	5	1	50-150	<50	70-130	<50	95
6010B	Barium	100	20	50-150	<50	70-130	<50	95
6010B	Cadmium	1	0.2	50-150	<50	70-130	<50	95
6010B	Chromium	5	1	50-150	<50	70-130	<50	95
6010B	Lead	5	1	50-150	<50	70-130	<50	95
7470	Mercury	0.2	0.04	50-150	<50	70-130	<50	95
6010B	Selenium	1	0.2	50-150	<50	70-130	<50	95
6010B	Silver	5	1	50-150	<50	70-130	<50	95
<b>Characteristics</b>		(mg/kg)	(mg/kg)	(%)	(%)	(%)	(%)	(%)
7.3	Reactive Sulfide	500	50	N/A	<50	N/A	<50	95
7.3	Reactive Cyanide	250	25	N/A	<50	N/A	<50	95
1010	Ignitability (Pensky Martens)	< 60 C or <140°F	40 C or 100°F	N/A	<50	N/A	<50	95
1020A	Ignitability (Setaflash)	< 60 C or <140°F	40 C or 100°F	N/A	<50	N/A	<50	95
1030	Ignitability of Solids	< 60 C or <140°F	40 C or 100°F	N/A	<50	N/A	<50	95
9040	pH (Corrosivity)	≤2 ; ≥12.5	N/A	N/A	<50	N/A	<50	95
<b>Miscellaneous</b>				(%)	(%)	(%)	(%)	(%)
9095A	Paint Filter	Pass	Pass/Fail	N/A	N/A	N/A	N/A	95

**TABLE A-2**  
**PROJECT QUALITY CONTROL OBJECTIVES**

Method No	Analyte / Component	Project Action		Minimum PQL		Accuracy Limits		Precision Limits		Accuracy Limits		Precision Limits		Completeness Limits	
		Limits		Water	Soil	Water	Soil	Water	Soil	Water	Soil	Water	Soil	Field Dup Deviation	
		Water	Soil											Water	Soil
	<b>VOLATILES</b>	ug/L	ug/kg	ug/L	ug/kg	ug/L	ug/kg	%	%	%	%	%	%	%	%
601	Chloromethane	NS	NA	0.08	NA	40-120	NA	<30	NA	D-193	NA	<50	NA	95	NA
601	Bromomethane	NS	NA	1.18	NA	40-120	NA	<30	NA	D-144	NA	<50	NA	95	NA
601	Vinyl Chloride	NS	NA	0.015	NA	40-120	NA	<30	NA	28-163	NA	<50	NA	95	NA
601	Chloroethane	NS	NA	0.52	NA	40-120	NA	<30	NA	46-137	NA	<50	NA	95	NA
601	Methylene Chloride	NS	NA	0.25	NA	40-120	NA	<30	NA	25-162	NA	<50	NA	95	NA
601	Trichlorofluoromethane	NS	NA	ND	NA	40-120	NA	<30	NA	21-156	NA	<50	NA	95	NA
601	1,1-Dichloroethene	NS	NA	0.13	NA	40-120	NA	<30	NA	28-167	NA	<50	NA	95	NA
601	1,1-Dichloroethane	NS	NA	0.07	NA	40-120	NA	<30	NA	47-132	NA	<50	NA	95	NA
601	trans-1,2-Dichloroethene	NS	NA	0.1	NA	40-120	NA	<30	NA	38-155	NA	<50	NA	95	NA
601	Chloroform	NS	NA	0.05	NA	40-120	NA	<30	NA	49-133	NA	<50	NA	95	NA
601	1,2-Dichloroethane	NS	NA	0.03	NA	40-120	NA	<30	NA	51-147	NA	<50	NA	95	NA
601	1,1,1-Trichloroethane	NS	NA	0.03	NA	40-120	NA	<30	NA	41-138	NA	<50	NA	95	NA
601	Carbon Tetrachloride	NS	NA	0.12	NA	40-120	NA	<30	NA	43-143	NA	<50	NA	95	NA
601	Bromodichloromethane	NS	NA	0.1	NA	40-120	NA	<30	NA	42-172	NA	<50	NA	95	NA
601	1,2-Dichloropropane	NS	NA	0.04	NA	40-120	NA	<30	NA	44-156	NA	<50	NA	95	NA
601	cis-1,3-Dichloropropene	NS	NA	0.2	NA	40-120	NA	<30	NA	22-178	NA	<50	NA	95	NA
601	Trichloroethylene	NS	NA	0.12	NA	40-120	NA	<30	NA	35-146	NA	<50	NA	95	NA
601	Dibromochloromethane	NS	NA	0.09	NA	40-120	NA	<30	NA	24-191	NA	<50	NA	95	NA
601	1,1,2-Trichloroethane	NS	NA	0.02	NA	40-120	NA	<30	NA	39-136	NA	<50	NA	95	NA
601	trans-1,3-Dichloropropene	NS	NA	0.2	NA	40-120	NA	<30	NA	22-178	NA	<50	NA	95	NA
601	2-Chloroethylvinyl ether	NS	NA	0.13	NA	40-120	NA	<30	NA	14-186	NA	<50	NA	95	NA
601	Bromoform	NS	NA	0.19	NA	40-120	NA	<30	NA	13-159	NA	<50	NA	95	NA
601	1,1,2,2-Tetrachloroethane	NS	NA	0.03	NA	40-120	NA	<30	NA	8-184	NA	<50	NA	95	NA
601	Tetrachloroethene	NS	NA	0.03	NA	40-120	NA	<30	NA	26-162	NA	<50	NA	95	NA
601	Chlorobenzene	NS	NA	0.25	NA	40-120	NA	<30	NA	38-150	NA	<50	NA	95	NA
601	1,3-Dichlorobenzene	NS	NA	0.32	NA	40-120	NA	<30	NA	7-187	NA	<50	NA	95	NA
601	1,2-Dichlorobenzene	NS	NA	0.15	NA	40-120	NA	<30	NA	D-208	NA	<50	NA	95	NA
601	1,4-Dichlorobenzene	NS	NA	0.24	NA	40-120	NA	<30	NA	42-143	NA	<50	NA	95	NA
602	Benzene	NS	NA	0.2	NA	40-120	NA	<30	NA	39-150	NA	<50	NA	95	NA
602	Chlorobenzene	NS	NA	0.2	NA	40-120	NA	<30	NA	55-135	NA	<50	NA	95	NA
602	Ethylbenzene	NS	NA	0.2	NA	40-120	NA	<30	NA	32-160	NA	<50	NA	95	NA
602	Toluene	NS	NA	0.2	NA	40-120	NA	<30	NA	46-148	NA	<50	NA	95	NA
602	total Xylenes	NS	NA	0.2	NA	40-120	NA	<30	NA	45-150	NA	<50	NA	95	NA

**APPENDIX B**

**CUSTODY SEAL  
CHAIN-OF-CUSTODY RECORD  
OHM SHIPPING LABEL  
SHIPPING INSTRUCTIONS FOR SENDING  
SAMPLES TO THE LABORATORY**

Client \_\_\_\_\_  
Sample ID \_\_\_\_\_  
Location \_\_\_\_\_  
Analysis \_\_\_\_\_  
Preservative \_\_\_\_\_  
Collection Date/Time \_\_\_\_\_  
Collected By \_\_\_\_\_

**CUSTODY SEAL**

Person Collecting Sample \_\_\_\_\_ Sample No. \_\_\_\_\_  
(signature)

Date Collected \_\_\_\_\_ Time Collected \_\_\_\_\_

**Custody Seal**

**Sample Label**



**OHM Remediation  
Services Corp.**



**OHM Remediation Services Corp**  
 Subsidiary of OHM Corporation  
 U.S. Route 224 East • Findlay, Ohio 45840 • (419) 423-3526

**CHAIN-OF-CUSTODY RECORD**

PROJECT DATA MANAGER'S COPY

206847

FORM 0019 REV 2-97

OHM & LAB COORDINATOR 1	LAB COORDINATOR'S PHONE 2	LAB COORDINATOR'S FAX 3	LABORATORY SERVICE ID 16	LABORATORY CONTACT 17	MAIL REPORT / COMPANY NAME 22
PROJECT NAME 4	PROJECT LOCATION 5	PROJECT NUMBER 6	LABORATORY PHONE 18	LABORATORY FAX 19	RECIPIENT NAME 23
PROJECT CONTACT 7	PROJECT PHONE NUMBER 8	PROJECT FAX 9	LABORATORY ADDRESS 20		ADDRESS 24
PROJECT ADDRESS 10	CITY, STATE AND ZIP CODE 11	CLIENT 12	CITY, STATE AND ZIP CODE 21		CITY, STATE AND ZIP CODE 25
PROJECT MANAGER 13	PROJECT MANAGER'S PHONE 14	PROJECT MANAGER'S FAX 15			

Item	Sample Identifier	Matrix	Date	Time	Preserved	# of Cont.	QC Level	T.A.T.	Analyses 34	Comments
1	26		27	28	29	30	31	32	33	35
2										
3										
4										
5										
6										
7										
8										
9										
10										

SAMPLES COLLECTED BY 36	CARRIER AND AIR BILL NUMBER 37	COOLER TEMPERATURE RECEIPT	
38	39	40	41

Distribution: White - Laboratory (To be returned with Analytical Report); Goldenrod - Project File; Yellow - Project Data Manager

**Project Information Section  
For Project Personnel Only  
Do Not Submit to Laboratory**

Sample Point Location	Sample Type			
	G	C	F	QC
42		43		
Comments				
44				
Sample Type: G - Grab, C - Composite, F - Field Sample, QC - Quality Control Sample				

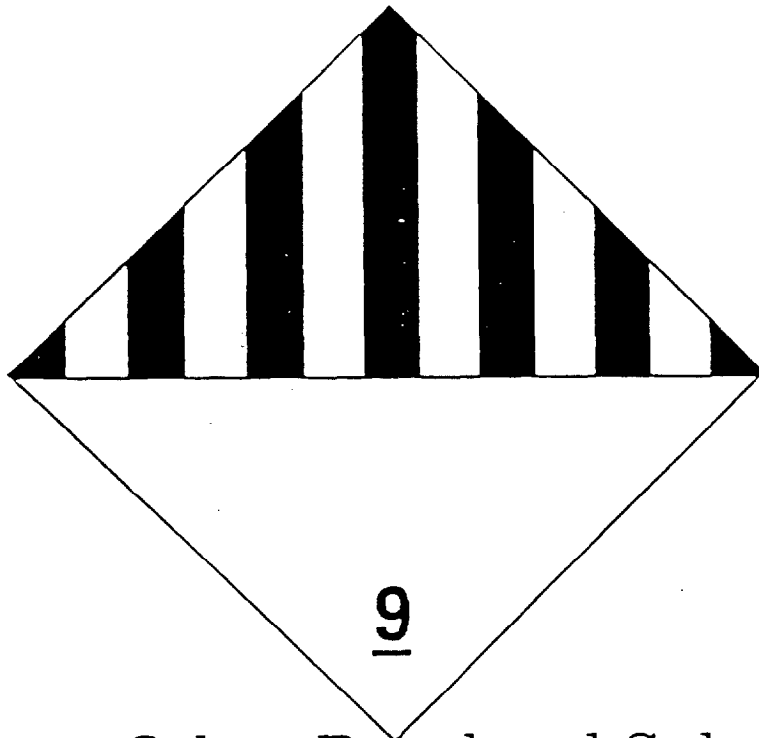

OHM Corporation



From:

Phone:

To:

Phone:

Other Regulated Substances, ID# 8027

**Class 9 Shipping Label**



**OHM Remediation  
Services Corp.**





**OHM Remediation  
Services Corp**

**Shipping Instruction  
for  
Sending Samples to the Lab**

**NOTE:** These procedures are ONLY for shipping unknown environmental samples such as sludge, soil, or water samples for laboratory analysis & identification; Materials which are known to be explosive, compressed gases, flammable, oxidizers, poisons, radioactive, or corrosive cannot be shipped by this method. Call the Regional T&D Coordinator for help in that case. Drum or tank materials must be shipped as per the Regional T&D Coordinator's instructions.

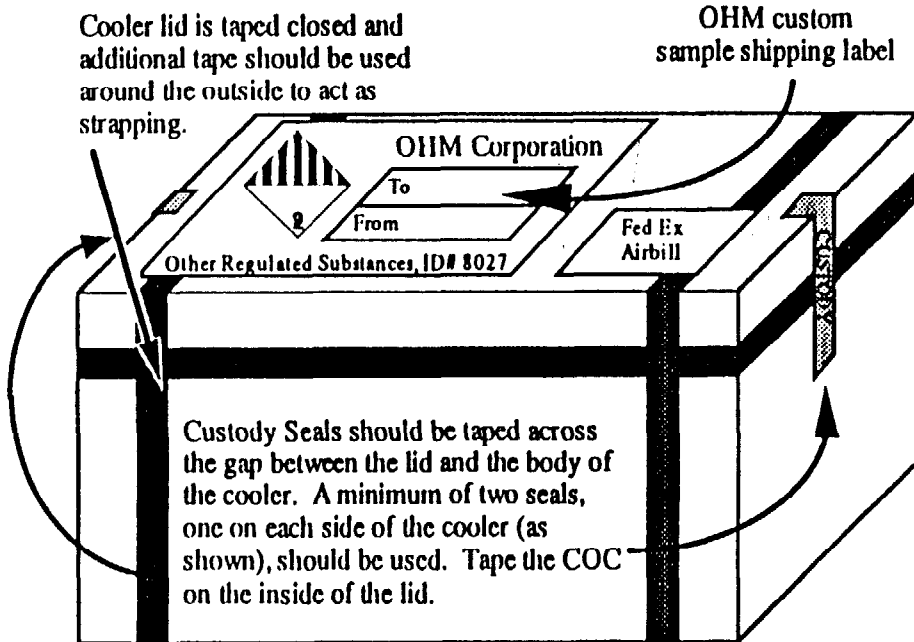

- 1) Samples must be shipped in "Strong outer packaging". Fed-Ex stated that a rigid plastic cooler like we are currently using would be acceptable.
- 2) Use one of OHM's custom sample shipping labels. The To/From address portion of the label should be filled out completely including phone numbers. This label should be placed on last and cannot be covered by tape, the Fed-Ex airbill or anything else. This label should go on the TOP of the cooler.
- 3) Inner packages cannot exceed 1 gallon each, and the entire shipment (cooler & samples) cannot exceed 66 lb.
- 4) Coolers must be packed with absorbent material (vermiculite or kitty litter) which will absorb any spills or leaks, not react with the sample contents, and which will minimize the chance that inner containers will break. The coolers should also be fastened shut securely using tape or strapping. See the SAP for special instructions.
- 5) Inner containers should have their lids securely closed and packed in a ziplock baggie to prevent leaks
- 6) The materials must be shipped using a Federal Express Hazardous Materials Airbill. Use the example above or call the Hazardous Materials group at Federal Express at (800) GO-FEDEX for more instructions on filling out this form.
- 7) The COC must be filled out completely, placed in a gallon zip-lock baggie, and taped to the inside lid of the cooler. A copy of the COC should be placed behind the airbill in the pouch on the outside of the cooler.

**Lower Portion of Fed-Ex  
DANGEROUS GOODS airbill**

0792772120

The completed and signed copies of this Declaration must be provided to the operator.

**WARNING!**  
Failure to comply in all respects with the applicable Dangerous Goods Regulations may be in breach of the applicable law, subject to legal penalties. This Declaration must not, in any circumstances, be completed and/or signed by a consolidator, a forwarder or an IATA cargo agent.

Transport Details  
The consignment is to be transported by air  
Type of Dangerous Goods:  **NON-RADIOACTIVE**

**NATURE AND QUANTITY OF DANGEROUS GOODS**

Proper Shipping Name	Class or Division	UN ID No.	Packing Group	Quantity and type of packing	Packing Inst.	Authorization
Other Regulated Substances	Class 9	ID 8027	NA	Plastic Box Containing _____ x 1 kg inner containers	906	

Additional Handling Information

I hereby declare that the contents of this consignment are fully and accurately described above by proper shipping name and are classified, packed, marked, and labeled, and are in all respects in the proper condition for transport by air according to the applicable International and National Government Regulations.

Emergency Response Number (Required for all types of Dangerous Goods)

ADDITIONAL INFORMATION FOR THE DRIVER OF THE VEHICLE OR AIRCRAFT IN WHICH THE GOODS ARE TRANSPORTED

Don't forget to sign and include the 24-hr Emergency Response Phone number. Check with the Regional T&D Coordinator for this number

Lids are taped to prevent leaks or loosening. Entire jar is sealed in a zip-lock baggie

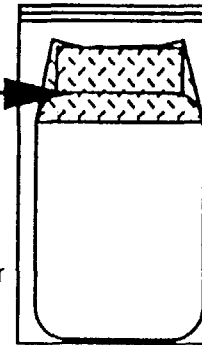

Fill in the blank with the number of containers

- \_\_\_ x 1 kg for quart jars
- \_\_\_ x 500 g for 8 oz jars
- \_\_\_ x 40 g for VOA vials

Fill in the Additional Handling space with:

"Samples from OHM Job # \_\_\_\_\_ see attached chain of custody. In case of emergency refer to ICAO Emergency Response Guidance for Aircraft Incidents Involving Dangerous Goods drill #9A"

**READ THE DIRECTIONS ON THE AIRBILL SO YOU UNDERSTAND WHAT YOU ARE FILLING OUT. Fill out the Fed-Ex airbill completely. Don't forget to sign the bottom and include the Emergency Response phone number. Changing even one thing from the example above may mean that Fed-Ex will refuse to accept the shipment. This procedure has been checked-out with Fed-Ex several times. If a driver refuses to pick it up make sure you have filled out the airbill right and followed ALL the instructions before you complain.**

## **APPENDIX C**

### **SOPs**

**QP-650 STANDARD ANALYTICAL DATA DELIVERABLE REQUIREMENTS**  
**QP-618 BAILERS**



## STANDARD OPERATING PROCEDURE

---

Title: Standard Analytical Data Deliverable Document #: QP-650

Date Issued: June 20, 1996

Rev: 0

Date:

---

### 1.0 PURPOSE

- 1.1 The purpose of this procedure is to set forth guidelines for the standardization of hard copy analytical data packages provided to OHM by Analytical Laboratories. This procedure defines the specific deliverable requirement to be include when a minimum data packages, standard data packages and maximum data packages is requested by OHM employees.

### 2.0 SCOPE

- 2.1 These procedures applies to all purchases of analytical services and the analytical data packages provided to OHM by all analytical laboratories.

### 3.0 RELATED DOCUMENTS

- 3.1 HAZWRAP, July 1990. Quality Control Requirements for Field Methods DOE/HWP69/R1.
- 3.2 HAZWRAP, July 1988. Requirements for Quality Assurance of Analytical Data, DOE/HWP-65, Rev. 0, July 1988.
- 3.3 USEPA , Test Methods for Evaluating Solid Waste Physical/Chemical Methods SW-846
- 3.4 United States Environmental Protection Agency, 1984. User's Guide to the Contract Laboratory Program, Office of Emergency and Remedial Response, Washington, D.C.

## 4.0 GENERAL INFORMATION

- 3.1 In the past OHM has experienced that Each analytical laboratory has a different report format that they call their standard deliverable package. Many times the laboratory's standard deliverable package does not include all of the information required to meet our client's expectations in performing data assessment and data validation of the analytical deliverable. When the additional information has been requested from the laboratories often additional charges are levied. In order to better service our client and to assure each and every laboratory bidding on a given set of samples understands precisely what is required to be included within each analytical report, the following procedures have been developed.

## 5.0 DEFINITIONS

- 5.1 Accuracy - A measure of how close a measured value is to a known true value.
- 5.2 Aliquot - A measured portion of a sample taken for analysis.
- 5.3 Analytical Batch - Batch size is determined the analytical method and project specific quality assurance requirements. Batch size is usually set at 20 or less samples of the same matrix being analyzed for the same parameters at the same time. All samples in a batch are prepared and analyzed together with a basic set of QC samples. Specific project requirements are listed in the Quality Assurance Project Plan (QAPP).
- 5.4 Background Correction - A technique usually employed relative to metals analysis which compensates for variable background contribution to the instrument signal in the determination of trace elements
- 5.5 Blank - An artificial sample designed to monitor the introduction of artifacts into the measurement process.
- 5.6 Calibration - The systematic determination of the relationship of the response of the measurement system to the concentration of a analyte of interest
- 5.7 Chain-of-Custody - A form used to track the custody of the samples from the time they are taken until the time they are analyzed.
- 5.8 Continuing Calibration - Subsequent checks on the instrument calibration performed throughout the analysis of samples.

- 5.9 Data Assessment - A systematic review of the analytical data to assure all method specific requirement were performed.
- 5.10 Data Quality Objectives - The established quality of the data required to support specific decisions or regulatory actions. DQOs must take into account sampling considerations as well as analytical protocols.
- 5.11 Data Validation - A systematic effort to review data for identification of errors for the purpose of flagging suspected values to assure the validity of the data for the user.
- 5.12 Deliverables - Analytical Report Package provide by the analytical laboratory which includes the analytical data and a specified set of supporting documentation.
- 5.13 Hold Times - The time stipulated in the method or regulations which is allowed to elapse from the time of sampling to the time of extraction and/or analysis. Samples analyzed after the hold times are of questionable usefulness.
- 5.14 ICP - Inductively coupled argon plasma (also referred to ICAP). An instrument used for metals analysis.
- 5.15 Internal Standard - A compound added to every standard, blank, matrix spike, matrix spike duplicate, sample and/or sample extract at a known concentration, prior to analysis. Internal standards are used as the basis for quantification of the target compounds.
- 5.16 Initial Calibration - Instrument calibration performed before any samples are analyzed.
- 5.17 Laboratory Control Sample - An artificial sample usually prepared in the laboratory, which either contains all or some of the compounds of interest. The sample is processed through the entire procedure including sample preparation and analysis. This sample is used to verify that the method is being performed properly. One laboratory control sample should be analyzed with each analytical batch.
- 5.18 Matrix Spike - An Aliquot of a sample that has been spiked with a known quantity of specified compounds of interest. The matrix spike is used to measure the accuracy of the analytical system.

- 5.19 Matrix Spike Duplicate - A second aliquot of the same sample used for the matrix spike spiked the same way as the matrix spike. The matrix spike duplicate is used to measure the precision of the analytical system..
- 5.20 Maximum Deliverable Package - Specific requirement set forth in this document to be provided to OHM by the Analytical Laboratory when a Maximum Deliverable Package is requested.
- 5.21 Minimum Deliverable Package - Specific requirement set forth in this document to be provided to OHM by the Analytical Laboratory when a Minimum Deliverable Package is requested.
- 5.22 Precision - a measure of the analytical method's ability to reproduce analytical results.
- 5.23 Preparation Logs - An official laboratory record of the sample preparation procedures used in processing a sample prior to analysis.
- 5.24 Standard Deliverable Package - Specific requirement set forth in this document to be provided to OHM by the Analytical Laboratory when a Standard Deliverable Package is requested.
- 5.25 Surrogate - An organic compound that is similar to the analytes of interest in chemical composition, extraction and chromatography, but are not normally found in environmental samples. These compounds are spiked into quality control samples, calibration and check standards and samples prior to analysis.
- 5.26 Tentatively Identified Compounds (TICs) - Compounds detected in samples that are not target compounds. Usually TICs consist of up to 30 peaks identified that are greater than 10 percent of the peak areas or heights of the nearest internal standard are subjected to mass spectral library searches for tentative identification.
- 5.27 Tuning - A technique used in gas chromatography/mass spectrometry procedures to verify that the instrument is properly calibrated to produce reliable mass spectral information.

## **6.0 RESPONSIBILITIES**

- 6.1 Regional Field Analytical Manager - Responsible for the management of the Regional Field Analytical Department. Responsible for distributing these requirements to all subcontract laboratories used within there

## **7.0 PROCEDURE**

- 7.1 All laboratories providing analytical services to OHM will be provided with a copy of these specification for minimum, standard and maximum data deliverable packages.
- 7.2 The desired data deliverable package will be selected at the time of procuring the analytical services. All price quotations must include providing OHM with the requested deliverable package.
- 7.3 All Data packages received must meet the requested requirements as specified in the Data Deliverables Package Requirements.

## **8.0 ATTACHMENTS**

- 8.1 Data Deliverables Package Requirements Table



# ATTACHMENT 8.1

## DATA DELIVERABLE PACKAGE REQUIREMENTS TABLE

**DATA DELIVERABLE PACKAGE REQUIREMENTS TABLE**

Method	Deliverable Requirement	Equivalent EPA Form	OHM Minimum Level	OHM Standard Level	OHM Maximum Level
Metals	Case Narrative		X	X	X
	Corrective Action Report		X	X	X
	Cross-reference of OHM Sample Numbers, Lab IDs, and analytical QC batches		X	X	X
	Chain-of-Custody Form, Cooler Receipt form		X	X	X
	Data Summary for Each Sample (See Note 1)	I-IN	X	X	X
	Blank Spike or Lab Control Sample (LCS) results (including concentration spiked, percent recovered, percent recovery acceptance limits)	VII-IN	X	X	X
	Matrix Spike (MS) Report (including concentration spiked, percent recovered, percent recovery acceptance limits)	V (PART 1)IN	X	X	X
	Post-digestion Spike Recovery for ICP	V (PART 2)IN	X	X	X
	Duplicate Sample Report		X	X	X
	Blank Results	III-IN	X	X	X
	Initial Calibration Data	III-IN		X	X
	Continuing Calibration Data	II (PART I)-IN		X	X
	ICP Interference Check Sample Report	II (PART I)-IN		X	X
	Standard Addition Results	IV-IN		X	X
	ICP Serial Dilution Results	VIII-IN			X
	Copies of Preparation Logs	IX-IN			X
	Copies of Analysis Run Logs	XIII-IN		X	X
	Copies of Standard Preparation Logs	XIV-IN			X
	Raw Data and Instrument Printouts				X
	Percent Moisture			X	X
pH					X (Note 2)

## DATA DELIVERABLE PACKAGE REQUIREMENTS TABLE

Method	Deliverable Requirement	Equivalent EPA Form	OHM Minimum Level	OHM Standard Level	OHM Maximum Level
Organics by GC or HPLC	Case Narrative		X	X	X
	Corrective Action Report		X	X	X
	Cross-reference of OHM Sample Numbers, Lab IDs, and analytical QC batches	IV	X	X	X
	Chain-of-Custody Form, Cooler Receipt form		X	X	X
	Data Summary for each blank and sample (See Note 1)	I	X	X	X
	Blank Spike or Lab Control Sample (LCS) results (including concentration spiked, percent recovered, percent recovery acceptance limits)		X	X	X
	Surrogate Recovery Report (including concentration spiked, percent recovered, and percent recovery acceptance limits)	II	X	X	X
	Matrix Spike/Matrix Spike Duplicate (MS/MSD) Report (including concentration spiked, percent recovered, percent recovery acceptance limits, relative percent difference (RPD), and RPD acceptance limits)	III	X	X	X
	Initial Calibration Data for each column (indicate which column was used for quantitation)	VI		X	X
	Continuing Calibration Data (indicate which column was used for quantitation)	VII		X	X
	Chromatograms for each sample (and reruns), confirmation runs, blank, spike, duplicate, and standards			X (Note 4)	X
	Raw Quantitation Report (area vs. retention time)				X
	Copies of Sample Preparation Bench Sheets			X	X
	Copies of Standard Preparation Logs				X
	Copies of Run Logs	VIII			X

## DATA DELIVERABLE PACKAGE REQUIREMENTS TABLE

Method	Deliverable Requirement	Equivalent EPA Form	OHM Minimum Level	OHM Standard Level	OHM Maximum Level
Organics by GC/MS	Case Narrative		X	X	X
	Corrective Action Report		X	X	X
	Cross-reference of OHM sample numbers, Lab IDs, and analytical QC batches	IV		X	X
	Chain-of-Custody Form, Cooler Receipt Form		X	X	X
	Data Summary for each blank and sample (See Note 1)	I	X	X	X
	Tentatively Identified Compounds (TICs) for each sample (ten peaks)	I,TIC		X	X
	Blank Spike or Lab Control Sample (LCS) results (including concentration spiked, percent recovered, percent recovery acceptance limits)		X	X	X
	Surrogate Recovery Report (including concentration spiked, percent recovered, and percent recovery acceptance limits)	II	X	X	X
	Matrix Spike/Matrix Spike Duplicate (MS/MSD) Report (including concentration spiked, percent recovered, percent recovery acceptance limits, relative percent difference (RPD), and RPD acceptance limits)	III	X	X	X
	Instrument Performance Check (Tuning) Report	V		X	X
	Initial Calibration Data (including acceptance limits)	VI		X	X
	Continuing Calibration Data (including acceptance limits)	VII		X	X
	Internal Standard Areas and Retention Times Reports (including acceptance limits and out-of-control flags)	VIII		X	X
	Reconstructed Ion Chromatogram for each sample and rerun, blank, spike, duplicate, and standard				X
	Raw Quantitation Report				X
	Raw and background subtracted mass spectra for each target analyte found				X
	Mass spectra of TICs with library spectra of 5 best-fit matches				X
	Copies of Sample Preparation Bench Sheets			X	X
	Copies of Standard Preparation Logs				X
	Copies of Run Logs				X
Percent Moisture			X	X	X
pH					X (Note 3)

## DATA DELIVERABLE PACKAGE REQUIREMENTS TABLE

Method	Deliverable Requirement	Equivalent EPA Form	OHM Minimum Level	OHM Standard Level	OHM Maximum Level	
Inorganic Chemistry (Note 2)	Corrective Action Report		X	X	X	
	Cross-reference of OHM sample numbers, Lab IDs, and analytical QC batches		X	X	X	
	Chain-of-Custody Form, Cooler Receipt form		X	X	X	
	Data Summary for each blank and sample (See Note 1)		X	X	X	
	Blank Spike or Lab Control Sample (LCS) results (including concentration spiked, percent recovered, percent recovery acceptance limits)		X	X	X	
	Matrix Spike/Matrix Spike Duplicate (MS/MSD) Report (including concentration spiked, percent recovered, percent recovery acceptance limits)		X	X	X	
	Duplicate Sample Report		X	X	X	
	Calibration Reports Initial and Continuing			X	X	
	Copies of Sample Preparation logs				X	
	Raw Data and Instrument Printouts				X	
	Percent Moisture			X	X	X

Notes:

- 1) Must include: OHM sample ID, Lab ID, date/time sampled, date received, extracted/analyzed, Practical Quantitation Limit, Method Detection Limit, Dilution Factor, comments, approval signature/date.
- 2) For water samples only.
- 3) Must include: OHM sample ID, Lab ID, date/time sampled, date received, extracted/analyzed, Practical Quantitation Limit, Method Detection Limit, Dilution Factor, comments, approval signature/date.
- 4) For petroleum fuels analyses chromatograms for samples with positive results only.
- 5) Deliverables depend on method's QC.



## STANDARD OPERATING PROCEDURE

---

Title: Bailers

Document #: QP-618

Date Issued: January 17, 1994

Rev: 0

Date: December 17, 1994

---

### 1.0 PURPOSE

- 1.1 To provide general information and procedures for the bailer sampling device.

### 2.0 SCOPE

- 2.1 The bailer is designed for obtaining liquid samples. The bailer can be constructed of PVC, Teflon, stainless steel or a combination of these materials. Disposable bailers intended for one time use only are usually made from polyethylene plastic or Teflon.

### 3.0 RELATED DOCUMENTS

- 3.1 OHM Field Sampling Manual

### 4.0 GENERAL INFORMATION

- 4.1 The bailer is one of the oldest and simplest methods available. It consists of a container attached to a cable which is lowered into a well to retrieve a sample. Bailers can be of various designs. The simplest is a weighted bottle or basally capped length of pipe which fills from the top as it is lowered into the well. Top filling bailers are acceptable for well purging but not for sampling. More sophisticated bailers have a check valve located at the base which allows water to enter from the bottom as it is lowered into the well. When the bailer is lifted, the check valve closes, allowing water in the bailer to be brought to the surface. More sophisticated bailers are available that remain open at both ends while lowered into the well, but can be sealed at both top and bottom by

activating a triggering mechanism from the surface. This allows for more reliable sampling at discrete depths within a well. Perhaps the best known bailer of this design is the Kemmerer sampler.

- 4.2 Bailers generally provide an excellent means for collecting samples from monitoring wells. They can be constructed from a wide variety of materials compatible with the parameter of interest. Only Teflon and stainless steel bailers are acceptable for all parameters. Since they are relatively inexpensive, bailers can be easily dedicated to an individual well to minimize cross contamination during sampling. If not dedicated to a well, they can be easily cleaned to prevent cross contamination. Nylon sample string is commonly used to raise and lower bailers. Monofilament line (fishing line), however, is more acceptable.

## 5.0 DEFINITIONS

- 5.1 Representativeness - The sample should possess the same qualities or properties (which are relevant to the investigation) as the whole of the material under investigation.
- 5.2 Grab Sample - A single sample representative of a specific location at a given point in time.
- 5.3 Composite Sample - Combination of more than one sample collected at various sampling locations and/or different points in time.
- 5.4 Equipment (field) Blanks - Samples used to verify cleanliness of the sampling equipment. The piece of equipment in question is used to take a sample of distilled or deionized water. One per analyte per piece of equipment per day is recommended.
- 5.5 Cross Contamination - The introduction of contaminants into the sample through the sampling and/or sample-handling procedures which can cause an otherwise representative sample to become nonrepresentative.

## 6.0 RESPONSIBILITIES

- 6.1 The Sample Technician is responsible for all sample collection, documentation, and decontamination.



## 7.0 PROCEDURE

- 7.1 Assemble the decontaminated bailer (if necessary).
- 7.2 Securely attach sample string to the hole in the top of the bailer.
- 7.3 Slowly lower the bailer into the liquid to be sampled. Care should be taken not to drop the bailer into the structure being sampled.
- 7.4 Allow the bailer to fill with the liquid being sampled. Usually, a gurgling sound will be apparent when the bailer is filling.
- 7.5 When the bailer is full, remove it from the structure being sampled by pulling the string.
- 7.6 Position the hole on the bottom of the bailer over the appropriate sample container and push up on the Teflon ball to release the material. Alternatively the sample material can be poured from the top of the bailer into a sample container if the bailer design is an open top type.
- 7.7 After each use, the bailer must be decontaminated before using it again at a different sampling point. Check with the Project Chemist or the Site Supervisor for information on the correct decontamination procedures to use for the site where sampling was done.

## 8.0 EQUIPMENT

- \* Bailer
- \* Sample string or Nylon monofilament line
- \* Appropriate decontamination supplies

## 9.0 ATTACHMENTS

Figure 9-1 Teflon Bailer

**ENVIRONMENTAL PROTECTION PLAN  
FOR  
CONSTRUCTION OF NEW WELLS  
AT HADNOT POINT INDUSTRIAL AREA  
NORTH AND SOUTH GROUNDWATER TREATMENT PLANTS  
MCB CAMP LEJEUNE, NORTH CAROLINA**

Prepared for:

DEPARTMENT OF THE NAVY  
Contract No. N62470-93-D-3032  
Atlantic Division  
Naval Facilities Engineering Command  
6500 Hampton Boulevard  
Building A (South East Wing) 3<sup>rd</sup> Floor  
Norfolk, VA 23508

Prepared by:

OHM Remediation Services Corp.  
5445 Triangle Parkway, Suite 400  
Norcross, GA 30092

Reviewed by:

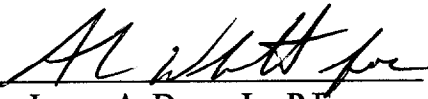
  
James A. Dunn, Jr., P.E.  
Project Manager

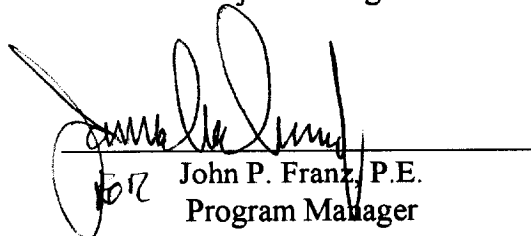
  
John P. Franz, P.E.  
Program Manager

September 1998  
Delivery Order 0175  
OHM Project No. 20500

***TABLE OF CONTENTS***

---

**1.0 INTRODUCTION..... 1-1**

**2.0 TEMPORARY CONSTRUCTION ROADS..... 2-1**

**3.0 PROTECTION OF TREES AND SHRUBS ..... 3-1**

**4.0 RESTORATION..... 4-1**

**5.0 WATER RESOURCES PROTECTION ..... 5-1**

    5.1 EROSION SEDIMENT CONTROL ..... 5-1

    5.2 MONITORING AND REPORTING REQUIREMENTS..... 5-1

    5.3 SPILL CONTROL ..... 5-1

**6.0 DUST AND AIR POLLUTION CONTROL..... 6-1**

    6.1 AIR AND NOISE MONITORING ..... 6-1

    6.2 PARTICULATE EMISSION CONTROLS ..... 6-1

    6.3 BURNING ..... 6-1

**7.0 POST EXCAVATION CLEANUP ..... 7-1**

**8.0 OPERATION AND MAINTENANCE PERIOD ..... 8-1**

## ***1.0 INTRODUCTION***

---

This Environmental Protection Plan (EPP) has been prepared in accordance with standard OHM policies and procedures. The EPP provides specific information relating to the scope of work under Delivery Order No. 0175 Construction of New Wells at Hadnot Point Industrial Area, North and South Groundwater Treatment Plant, MCB Camp Lejeune, North Carolina. The plan will provide site-specific information for:

- Land resources management
- Water resources management
- Air and noise pollution control
- Non-compliance/corrective action
- Post-evacuation cleanup

The control of environmental pollution will consider air, water and land impacts, as well as noise and solid waste management.

The land-resources within the property of MCB Camp Lejeune, but outside the limits of permanent work, will be preserved in their condition or restored to a condition after completion of construction that does not detract from the appearance of the area. As much as is practical, construction activities will be limited to areas defined by the plans and specifications.

## **2.0 *TEMPORARY CONSTRUCTION ROADS***

---

The construction of all temporary construction roads in and around the project site will be performed in a manner as to minimize the impact to the natural environment. Water will be used for dust control, as necessary. It is not expected that any new construction roads will be necessary for this removal action.

### ***3.0 PROTECTION OF TREES AND SHRUBS***

---

Prudent steps will be taken to protect trees and shrubs outside of the work zone as necessary. Those trees and shrubs within the work zone that are blocking access will be removed by OHM. All trees and shrubs removed as a result of the construction activities will be cut into manageable pieces. Precautions will be taken to minimize the construction activities' impact on existing vegetation and will include but not be limited to:

- Utilization of existing or temporary construction roads only
- Closely supervise equipment operators with an emphasis placed on preservation of vegetation in non-work areas
- Proper guidance of heavy equipment and truck operators by site personnel to minimize damage to adjacent vegetation not directly affected by construction activities
- Utilization of equipment appropriately designed and sized for precise excavation

#### **4.0 RESTORATION**

---

Upon completion of the field construction activities, disturbed areas will be seeded.

Any trees or other landscape features damaged by equipment will be restored if practical by trimming of damaged limbs and application of tree dressing. Damaged trees which cannot be restored will be felled, limbed and left on-site. Soil will be placed and compacted around any root systems exposed during excavation activities.

## **5.0 WATER RESOURCES PROTECTION**

---

The nearest body of water, Beaverdam Creek is located approximately 1,400 feet west of the site; however a stormwater concrete ditch system and associated retention pond are located near the construction areas. Therefore, proper prevention and erosion protection measures will be taken to protect against construction-induced damage. Stormwater surface run-off leaving the site will be controlled by temporary erosion/sediment control techniques such as berms, silt fencing and grading. The area of bare soil exposed at any one time by construction activities will be held at a minimum.

### **5.1 EROSION SEDIMENT CONTROL**

Prior to disturbance of native vegetation and soils, temporary erosion/sediment control will be established on the down gradient side of each excavation. Control techniques to be utilized will involve silt fencing.

Silt fencing will be installed with fabric a minimum of 6 inches below grade and extending 36 inches above grade and fastened to posts no more than 6 feet apart. The posts will be installed with a minimum of 24 inches below grade and extend a minimum of 36 inches above grade. Fabric will be attached to the upslope side of the posts using 1-inch staples or tie wires. Silt fences will be inspected after every rain and daily during extended rain fall. Accumulated sediment will be removed before the depth reaches 12 inches.

Check dams will be employed in existing drainage swales to permit sediment settling from storm flows

### **5.2 MONITORING AND REPORTING REQUIREMENTS**

Monitoring and reporting requirements are as follows:

- All sedimentation and erosion control facilities shall be inspected daily and after a storm event.
- Stormwater run-off discharge shall be inspected to evaluate the effectiveness of the pollution control facilities or practices. If any visible off-site sedimentation is leaving the site, corrective action shall be taken to reduce the discharge of sediments.

### **5.3 SPILL CONTROL**

Measures will be taken to prevent chemicals, fuels, oils, greases, bituminous materials and contaminated materials from entering storm sewers, swales, manholes, etc. Absorbants will be available to solidify any leaks outside containment and any soil contaminated with fuel spills will be immediately removed and placed into appropriate containers and sampled to determine proper disposition.



## **6.0 DUST AND AIR POLLUTION CONTROL**

---

### **6.1 AIR AND NOISE MONITORING**

Personnel and ambient air monitoring will be conducted as necessary in order to determine airborne dust and contaminant levels. Ambient air monitoring will be conducted at working locations and on occasion at the perimeter of the project site. This ensures that respiratory protection is adequate to protect personnel against the contaminants that are encountered as well as ensuring that harmful levels of airborne contaminants are not leaving the site.

OHM will only perform operations of heavy equipment during daylight hours to minimize the impact of noise pollution on off-site personnel. Noise exposure to off-site residents or personnel is expected to be minimal. Hearing protection will still be implemented if necessary as specified in the SHSP.

### **6.2 PARTICULATE EMISSION CONTROLS**

Specific measures to be taken to minimize particle emissions for major activities during site construction include the following:

#### ***Soil Excavation, Handling, Site Grading and Transportation***

- Apply water to work and traffic areas as necessary to minimize dust emissions
- Move and load soil for transport within the site that limits freefall of material and is least likely to generate dust emissions
- Halt dust-generating work when on-site wind conditions exceed 35 miles per hour.
- Movement of Equipment
- Water traffic areas as required to minimize dust emissions
- Designate equipment traffic patterns to minimize travel distance and vehicular dust emissions
- Limit vehicle speed to minimize dust emissions

### **6.3 BURNING**

No burning will be performed on-site. In the event of an expected fire on-site, work will stop immediately and the MCB Camp Lejeune fire department will be notified.

## ***7.0 POST EXCAVATION CLEANUP***

---

All equipment will be decontaminated prior to demobilizing from the site. Decontamination will consist of scraping and pressure-washing to remove visible soil and debris from tires and undercarriage of vehicles and heavy equipment. Decontamination fluids will be containerized and samples procured and analyzed prior to disposal.

## ***8.0 OPERATION AND MAINTENANCE PERIOD***

---

During the Operation and Maintenance period, OHM personnel will periodically check the erosion control measures. Once restoration of vegetation has occurred, the erosion and sedimentation control measures will be removed.

**TRANSPORTATION AND DISPOSAL PLAN  
FOR  
CONSTRUCTION OF NEW WELLS  
AT HADNOT POINT INDUSTRIAL AREA  
NORTH AND SOUTH GROUNDWATER TREATMENT PLANTS  
MCB CAMP LEJEUNE, NORTH CAROLINA**

Prepared for:

**DEPARTMENT OF THE NAVY  
Contract No. N62470-93-D-3032  
Atlantic Division  
Naval Facilities Engineering Command  
6500 Hampton Boulevard  
Building A (South East Wing), 3<sup>rd</sup> Floor  
Norfolk, VA 23508**

Prepared by:

**OHM Remediation Services Corp.  
5445 Triangle Parkway, Suite 400  
Norcross, GA 30092**

Reviewed by:

  
\_\_\_\_\_  
James A. Dunn, Jr., PE  
Senior Project Manager

  
\_\_\_\_\_  
Lisa Schwan  
Transportation and Disposal Coordinator

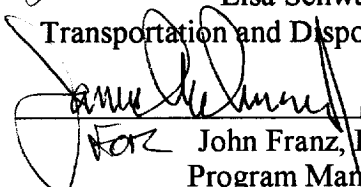
  
\_\_\_\_\_  
John Franz, P.E.  
Program Manager

September 1998  
Delivery Order 0175  
OHM Project No. 20500

***TABLE OF CONTENTS***

---

**1.0 INTRODUCTION..... 1-1**  
**2.0 CHARACTERIZATION OF WASTE STREAMS..... 2-1**  
**3.0 WASTE DISPOSAL APPROVAL ..... 3-1**  
**4.0 WASTE PACKAGING..... 4-1**  
**5.0 PREPARATION OF REQUIRED DOCUMENTATION..... 5-1**

## ***1.0 INTRODUCTION***

---

This Transportation and Disposal Plan (TDP) was prepared for use during remedial action activities at the Hadnot Point Industrial area which is located within the Marine Corps Base, Camp Lejeune, North Carolina.

The TDP objective is to specify the methods and procedures to be implemented by OHM to ensure that wastes generated during site remediation activities will be transported, stored, treated, and disposed of in full compliance with applicable federal, state, and local rules and regulations.

OHM envisions that all waste streams that are generated during construction activities will be classified non hazardous. As such, we recommend that the base landfill be utilized as the disposal site.

## 2.0 CHARACTERIZATION OF WASTE STREAMS

Based on the information provided to OHM in the Corrective Action Plan, OHM will generate various types of Remedial Derived Waste during the installation and operation of the remediation systems at these sites, which will require proper disposal. These materials are outlined in Table 11.1.

OHM will complete characterization and disposal analysis of the waste materials generated from the remedial activities. For the purposes of this plan, OHM assumes that contaminants of concern are benzene, toluene, ethylbenzene, and xylenes (BTEX) from previous Underground Storage Tank (UST), transfer line releases of gasoline and diesel fuel, and chlorinated solvents.

OHM will collect samples in accordance with the Sampling and Analysis Plan and perform appropriate characterization and disposal analysis of the wastes described in Table 11.1 during the course of these projects. Final characterization and disposal alternatives are contingent upon those analyses. An addendum to this plan will be prepared with that information when it is available.

<b>Table 11.1 - Remedial Activity Derived Waste</b>			
<i>Waste</i>	<i>Description</i>	<i>Estimated Quantity</i>	<i>Disposal Method</i>
PPE	Personal protective equipment generated during onsite remedial activity	5 drums	Subtitle D Landfill
Well drilling waste	Drilling waste generated during the well installation	5 drums	TBD (see below)
Decon water	Decontamination water from equipment cleanup and water from well development	2,000 gallons	North or South Plant
Piping trenches, vault installation	Excess soil materials from trenching and piping installation	N/A	Backfill for trenching activities
Hardscape	Asphalt and concrete removed during well installation and trenching		TBD (see below)

\*Any soil that meets the State of North Carolina Remediation guidance documentation for clean soil will be used for backfill. Any soil that is not deemed to be clean soil by Camp Lejeune will go off-site for bioremediation in accordance with all Local, State, and Federal Laws.

### **3.0 WASTE DISPOSAL APPROVAL**

---

OHM will assign a T&D Coordinator for this project who will report to the Project Manager as a single point-of-contact for all waste management activities. The individual assigned to this project will be familiar with all the applicable portions of RCRA, CERCLA, and SARA regulations -- especially 40 CFR 261 (Identification and Listing of Hazardous Wastes). In addition, this individual will be familiar with the State of North Carolina regulations related to hazardous and solid waste treatment, storage, disposal, and transportation. This individual will specify analyses needed to identify hazardous wastes. Based on this data and consultations with the Department of the Navy representatives, the project T&D Coordinator will assist the Department of Navy in identifying regulated wastes materials. The T&D Coordinator will also be responsible for preparing waste profiles to the selected disposal vendor and to coordinate disposal approvals.

Based on the materials identified that will require off-site disposal, it is anticipated that the wastes generated will not be RCRA hazardous pursuant to 40 CFR 261. The T&D Coordinator, in consultation with the project manager and procurement personnel, have reviewed potential vendors to pre-qualify transportation and disposal companies based on:

- NOV status
- Ability to handle the wastes identified
- Cost effectiveness of the available transportation and disposal options
- Past experience

At this time, OHM has identified the following qualified vendors to provide transportation and disposal of non-hazardous petroleum contaminated wastes from this Delivery Order:

- BFI Waste Systems
- East Carolina Environmental
- Chambers/USA Waste Systems



#### **4.0 WASTE PACKAGING**

---

All Personal Protective Equipment, decon water, well development water, and SVE condensate water will be stored in 55-gallon (17H open-top) steel drums and will be labeled and logged using OHM's standard drum inventory procedures. Pending approval from the GWTP, OHM will transport the water to Lot 203 GWTP or to the North or South Plant via tanker truck for treatment and disposal.

Drilling waste will be stored in a roll-off container pending receipt of analytical results. Analytical Method – TCLP (1311) will be used to characterize the waste for disposal purposes. OHM's T&D Coordinator will document the disposal of all waste. Appropriate measures will be taken to keep off-site back-up copies of this data as well.

Based on quantities of waste, OHM will bulk or package waste in roll-off containers for cost effective disposal. All materials will be accumulated on-site until sufficient quantities are available for shipment of a full load of drums or (20 to 30 cubic yards) of bulk material. OHM will conduct weekly inspections of the temporary waste storage areas. All temporary storage will comply with 40 CFR 262.34 and the applicable North Carolina regulations.

## ***5.0 PREPARATION OF REQUIRED DOCUMENTATION***

---

OHM will prepare or oversee the preparation of all paperwork associated with off-site disposal for review and signature by LANTDIV and EMD representatives. This will include TSDf waste profiles, and bill of lading or non-hazardous manifest. The selected vendor(s) will be required to provide all manifests, and other shipping paperwork. A completed example of all manifests, and other shipping paperwork will be provided for OHM's review and approval at least one week in advance of the scheduled start of shipments. After the documents are reviewed by OHM, they will be provided to the Navy's representative for review and signature. OHM's on-site personnel will receive final copies of all manifests, and other shipping paperwork at least 24 hours in advance of the scheduled start of shipments.

The disposal vendors will provide written verification that the proposed disposal site is permitted to accept the contaminated materials generated from the site. The disposal vendors shall provide written verification that wastes were actually delivered to the disposal site.

**CONSTRUCTION QUALITY CONTROL PLAN  
FOR  
CONSTRUCTION OF NEW WELLS  
AT HADNOT POINT INDUSTRIAL AREA  
NORTH AND SOUTH GROUNDWATER TREATMENT PLANTS  
MCB CAMP LEJEUNE, NORTH CAROLINA**

Prepared for:

DEPARTMENT OF THE NAVY  
Contract No. N62470-93-D-3032  
Delivery Order 0175

Prepared by:

OHM Remediation Services Corp.  
5445 Triangle Parkway, Suite 400  
Norcross, Georgia 30092

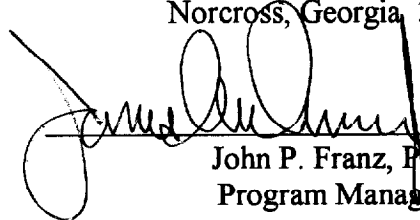

---

John P. Franz, P.E.  
Program Manager

---

Charles W. Hunter  
Program QC Manager



---

James A. Dunn, Jr., P.E.  
Senior Project Manager

September 1998

OHM Project No. 20500

# **TABLE OF CONTENTS**

---

<b>1.0</b>	<b>STATEMENT OF QC PROGRAM .....</b>	<b>1-1</b>
<b>2.0</b>	<b>QC ORGANIZATION AND RESPONSIBILITIES.....</b>	<b>2-1</b>
2.1	Organization .....	2-1
2.2	QC Managers.....	2-1
2.3	Duties, Responsibilities and Authorities .....	2-1
2.4	Appointment Letters.....	2-2
<b>3.0</b>	<b>SUBMITTALS.....</b>	<b>3-1</b>
3.1	Reviewing, Approving, and Managing Submittals .....	3-1
3.2	Personnel Authorized to Review and Certify Submittals.....	3-8
3.3	Submittal Register .....	3-8
<b>4.0</b>	<b>ACCREDITED LABORATORIES/TESTING LABORATORIES.....</b>	<b>4-1</b>
4.1	Testing Laboratory Requirements .....	4-1
4.2	Accredited Laboratories .....	4-1
4.3	Inspection of Testing Laboratories.....	4-2
4.4	Test Results .....	4-2
<b>5.0</b>	<b>TESTING PLAN AND LOG.....</b>	<b>5-1</b>
5.1	Testing Plan and Log.....	5-1
5.2	Testing.....	5-1
<b>6.0</b>	<b>REWORK .....</b>	<b>6-1</b>
6.1	Rework Documentation Requirements.....	6-1
<b>7.0</b>	<b>MEETING.....</b>	<b>7-1</b>
7.1	Coordination and Mutual Understanding Meeting .....	7-1
7.2	QC Meetings.....	7-1
<b>8.0</b>	<b>THREE PHASES OF CONTROL.....</b>	<b>8-1</b>
8.1	Preparatory Phase .....	8-1
8.2	Initial Phase .....	8-1
8.3	Follow-Up Phase .....	8-2
8.4	Notification of Three Phases of Control for Off-Site work.....	8-2
8.5	Receipt Inspection .....	8-2
8.6	Documentation .....	8-3
<b>9.0</b>	<b>DEFINABLE FEATURES OF WORK.....</b>	<b>9-1</b>
9.1	Definable Features of Work .....	9-1
<b>10.0</b>	<b>EXHIBITS.....</b>	<b>10-1</b>
10.1	Index of Exhibits .....	10-1

## ***1.0 STATEMENT OF QC PROGRAM***

---

OHM Remediation Services Corp. (OHM), a subsidiary of OHM Corporation, will provide and maintain an effective Contractor Quality Control (CQC) Program as required by contract clauses. This program will be performed in conjunction with the Program Quality Control Plan (OHM, December 14, 1995) as applicable and in accordance with the requirements of Contract No. N62470-93-D-3032, Atlantic Division, Naval Facilities Engineering Command, dated January 1998. OHM will perform the inspection and test required to ensure that materials, workmanship, and construction conform to drawings, specifications, and contract requirements. OHM will perform each test or inspection specified, unless the required inspection and/or test is specifically designated to be performed by the Government.

### Note to Employees

Quality Control should not be considered a person or an organization of personnel, but a concept to perform in such a manner that the end product of our efforts met established criterion, the customer's needs. The Quality Control individual or group cannot inspect quality into the final product, but only inspect and document the results of our efforts. The only person that can build quality into the product are the individuals performing the task of producing the end product.

It should be noted by all employees that the documentation requirements of OHM procedures, plans and the delivery order specifications are considered equally as important as the end product itself. When it is stated that the documentation will be approved prior to the start of work, this is exactly what is intended. To eliminate problems in this area requires careful planning and execution by everyone.

We would do well to remember that our livelihood depends on how well we satisfy our customer. To accomplish this requires teamwork and attention to detail by all employees and contractors.

## **2.0 QC ORGANIZATION AND RESPONSIBILITIES**

---

### **2.1 ORGANIZATION**

The QC organization is depicted in the Organizational Chart (Exhibit 2.1). Other positions are reflected to show organizational interface and lines of communication. Depending upon the scope, size and complexity of the project, the Project Superintendent may also fulfill the duties of the Project QC Manager when approved by the Navy.

### **2.2 QC MANAGERS**

The Program QC Manager's resume is included in the Program QC Plan and the QC Manager's resume (delivery order specific) is included herein as Exhibit 2.2.

### **2.3 DUTIES, RESPONSIBILITIES AND AUTHORITIES**

1. The **Program QC Manager** shall report to the Program Manager and shall be responsible for developing, maintaining, and enforcing the quality control program.
2. The **QC Manager** shall report to the Program QC Manager and shall be responsible for the management and implementation of the Program QC Plan and the delivery order specific QC Plan for both on-and off-site activities. Specific duties include: attend the Coordination and Mutual Understanding Meeting; conduct the scheduled QC meetings; perform the three phases of control; perform submittal reviews; perform submittal approval except for submittals designated for Contracting Officer approval; ensure tests are performed; and prepare QC certifications and QC documentation as required by this Plan. Except for managing and implementing the QC program, the QC Manager shall perform no other duties without the authorization of the Contracting Officer. The QC Manager shall also be responsible for delivering the following documentation to the Contracting Officer:
  - Combined Contractor Production Report/Contractor Quality Control Report, original and one copy, by 10:00 a.m. the next working day after each day that work is performed.
  - Testing Plan and Log, three copies, at the end of each month.

- Monthly Summary Report of Field Tests, original and two copies attached to the Contractor Quality Control Report at the end of each month. (See paragraph entitled “Test Results” in Section 4.0).
  - QC meeting minutes, three copies within two calendar days of the meeting.
  - Rework items list, three copies at the end of each month.
  - Completion Certification attesting that “the work has been completed, inspected, tested, and is in compliance with the contract.”
3. The QC Manager is expected to attend the daily site safety meetings and abide by all site rules and regulations.

#### **2.4 APPOINTMENT LETTERS**

The appointment letter for the site QC Manager is included as Exhibit 2.4. The appointment letter for the Program QC Manager can be found in the Program QC Plan.

### **3.0 SUBMITTALS**

---

#### **3.1 REVIEWING, APPROVING, AND MANAGING SUBMITTALS**

##### **A. Contractor's Responsibility**

The following responsibilities are those of the contractor and not the QC organization. They are included only for the purpose of providing an understanding of the contractor's responsibility. While the QC organization is expected to assist the contractor in fulfillment of their responsibilities, no part of these responsibilities shall be assumed by the QC organization without the expressed written permission of the Contracting Officer.

1. Coordinate preparation and processing of submittals with performance of work so that work will not be delayed by submittal processing. Allow for potential requirements to resubmit.
2. Except as specified otherwise, allow a review period, beginning with receipt by the approving authority, that includes at least 15 working days for submittals for QC Manager approval and 20 working days for submittals requiring Contracting Officer approval. The period of review for submittals with Contracting Officer approval begins when the Government receives the submittal from the QC organization. The period of review for each resubmittal is the same as for the initial submittal.
3. Determine and verify field measurements, materials, field construction criteria; review each submittal; check and coordinate each submittal with requirements of the work and contract documents.
4. Transmit submittals to the QC organization in orderly sequence, in accordance with the submittal register, and to prevent delays in the work, delays to the Government, or delays to separate contractors.
5. Correct and resubmit submittals as directed by the approving authority. Direct specific attention, in writing or on resubmitted submittals, to revisions not requested by the approving authority on previous submissions.
6. Furnish additional copies of submittals when requested by the Contracting Officer, to a maximum limit of 20 copies.



7. Complete work that must be accomplished as a basis of a submittal in time to allow the submittal to occur as scheduled.
8. Ensure no work has begun until submittals for that work have been returned as “approved” or “approved as noted” except to the extent that a portion of the work must be accomplished as a basis of the submittal.

- **Format of Submittals**

**Transmittal Form.** Transmit each submittal, except sample installations and sample panels, to the office of the approving authority utilizing transmittal forms standard for the project. The transmittal form shall identify the Contractor, indicate the date of the submittal, and include information prescribed by the transmittal form and required in the paragraph entitled “Identifying Submittals”. Process transmittal forms to record actions regarding sample panels and sample installations. Transmittal forms for submittals of sample panels and sample installations shall record any actions and locations of the samples.

**Identifying Submittals.** Identifying submittals, except sample panel and sample installation, submittals shall be identified with the following information permanently adhered to or noted on each separate component of each submittal and noted on the transmittal form. Mark each copy of each identically, with the following:

1. Project title and location.
2. Construction contract number and delivery order number.
3. The section and paragraph number of the section for which the submittal is required.
4. The Submittal Description (SD) number (see Exhibit 3.1) of each component of the submittal.
5. If a resubmittal, add an alphabetic suffix to the submittal description, for example, SD-10A, to indicate the resubmission.
6. The name, address, and telephone number of the subcontractor, supplier, manufacturer, and any other second tier contractor associated with the submittal.
7. Product identification and location in project.

- **Format of Product Data**

1. Present product data submittals for each section as a complete, bound volume. Include a table of contents listing page and catalog item numbers for product data.
2. Indicate, by prominent notation, each product that is being submitted, indicate the specification section number, and paragraph number to which it pertains.
3. Supplement product data with material prepared for the project to satisfy submittal requirements for which product data does not exist. Identify this material as developed specifically for the project.

- **Format of Shop Drawings**

1. Shop drawings shall be not less than 8 1/2 by 11 inches nor more than 30 by 42 inches.
2. Present 8 1/2 by 11 inches sized shop drawings as a part of the bound volume for the submittals required by the section. Present larger drawings in the sets.
3. Include on each drawing the drawing title, number, date, and revision numbers and dates, in addition to the information required in the paragraph entitled "Identifying Submittals."
4. Dimension drawings, except diagrams and schematic drawings; prepare drawings demonstrating interface with other trades to scale. Identify materials and products for work shown.

- **Format of Samples**

1. Furnish samples in the sizes below, unless otherwise specified or unless the manufacturer has prepackaged samples of approximately the same size as specified:
  - Sample of equipment or device: Full size.
  - Sample of materials less than 2 by 3 inches: Built-up to 8 1/2 by 11 inches.
  - Sample of materials exceeding 8 1/2 by 11 inches: Cut down to 8 1/2 by 11 inches and adequate to indicate color, texture, and material variations.

- Sample of linear devices or materials, such as conduit and handrails: 10-inch length or length to be supplied, if less than 10 inches.
  - Sample of non-solid naturals, (e.g., sand, paint, etc.): One pint, unless specified otherwise in technical sections.
  - Sample panel: 4 feet by 4 feet.
  - Sample Installation: 100 square feet.
2. Samples showing range of variation: Where unavoidable variations must be expected, submit sets of samples of not less than three units showing the extremes and middle of the range.
  3. Reusable samples: Incorporate returned samples into the work only if so specified or indicated. Incorporated samples shall be in an undamaged condition at the time of use.
  4. Recording of sample installation: Note and preserve the notation of the area constituting the sample installation but remove the notation at the final cleanup of the project.
  5. When a color, texture, or pattern is specified in naming a particular manufacturer and style, include one sample of that manufacturer and style, for comparison.

- **Format of Administrative Submittals**

1. When the submittal includes a document which is to be used in the project or become a part of the project record, other than as a submittal, do not apply the Contractor's approval stamp to the document, but to a separate sheet accompanying the document.
2. Operation and Maintenance Manual Data: Submit in accordance with the section entitled "Operation and Maintenance Data" of the individual delivery order.

- **Number of Copies of Product Data**

1. Submit six (6) copies of submittals of product data requiring review and approval only by the QC organization and seven (7) copies of product data requiring review and approval by the Contracting Officer.

- **Number of Copies of Shop Drawings**

1. For shop drawings presented on sheets larger than 8 1/2 by 14 inches, submit seven (7) prints of each shop drawing prepared for this project.
2. For shop drawings presented on sheets 8 1/2 by 14 inches or less, conform to the quality requirements for the product data.

- **Number of Samples**

1. Submit two (2) samples, or two (2) sets of samples showing range of variation of each required item. One (1) approved sample or set of samples will be retained by the approving authority and one will be returned to the Contractor.
2. Submit one (1) sample panel. Include components listed in the technical section or as directed.
3. Submit one (1) sample installation, where directed.
4. Submit one (1) sample of non-solid materials.

- **Number of Copies of Administrative Submittals**

1. Unless otherwise specified, submit administrative submittals which are 8 1/2 by 14 inches or smaller in size in the quantity required for product data.
2. Unless otherwise specified, submit administrative submittals larger than 8 1/2 by 14 inches in size in the quantities required for shop drawings.

## **B. QC Organization Responsibilities**

The Quality Control (QC) organization shall be responsible for reviewing and certifying that submittals are in compliance with contract requirements. The approving authority on submittals is the QC Manager unless submission to the Contracting Officer is specified for the specific submittal. The specific QC responsibilities for submittals are as follows:

1. Note the date on which the submittal was received from the contractor on each submittal for which the Site QC Manager is the approving authority.

2. Determine and verify field measurements, materials, field construction criteria; review each submittal; and check and coordinate each submittal with requirements of the work and contract documents.
3. Review submittals for conformance with project design concepts and compliance with the contract documents.
4. Act on submittals, determining the appropriate action based on the review of the submittal.
  - When the QC Manager is the approving authority, take the appropriate action on the submittal from the paragraph of “Possible Actions.”
  - When the Contracting Officer is the approving authority or when a variation has been proposed, forward the submittal to the Contracting Officer with the certifying statement or return the submittal marked “Not Reviewed” or “Revise and Resubmit” as appropriate.
5. Ensure that the material is clearly legible.
6. Stamp each sheet of each submittal with the appropriate stamp, except that data submitted in bound volume or on one sheet printed on two sides may be stamped on the front of the first sheet only. When agreed to by the Contracting Officer, a single cover sheet containing the required certification wording (see Exhibit 3.1a and 3.1b) may be utilized instead of the above. The stamp or cover sheet shall contain the following wording:
  - When the approval authority is the Contracting Officer, the QC organization will certify submittals forwarded to the Contracting Officer with the following certifying statement:
 

I hereby certify that the (equipment) (material) (article) shown and marked in this submittal is that proposed to be incorporated into Contract Number N62470-97D-5000, is in compliance with the Contract drawings and specification, can be installed in the allocated spaces, and is submitted for Government approval. Government approval of proposed variation, if any, is recommended.

Certified by Submittal Reviewer \_\_\_\_\_, Date \_\_\_\_\_

Certified by QC Manager \_\_\_\_\_, Date \_\_\_\_\_

- When approving authority is the QC Manager, the QC Manager will use the following approval statement when returning submittals to the Contractor as “Approved” or “Approved as Noted”:

I hereby certify that the (equipment) (material) (article) shown and marked in this submittal is that proposed to be incorporated into Contract Number N62470-97-D-5000, is in compliance with the Contract drawings and specification, can be installed in the allocated spaces, and is \_\_\_\_ approved for use, \_\_\_\_ approved for use subject to Government approval of proposed variation.

Certified by Submittal Reviewer \_\_\_\_\_, Date \_\_\_\_\_

Approved by QC Manager \_\_\_\_\_, Date \_\_\_\_\_

7. Sign the certifying statement or approval statement. The signatures shall be in original ink. Stamped signatures are not acceptable.
8. Update the submittal register as submittal actions occur and maintain the submittal register at the project site until final acceptance by the Contracting Officer.
9. Retain a copy of approved submittals at the project site, including the contractor’s copy of approved samples.
10. When the approving authority is the QC Manager, forward two copies of each approved submittal, except “Samples”, where only one set is required, to the Contracting Officer.

- **Actions Possible**

Submittals returned to the contractor shall contain one of the following notations:

1. **“Not Reviewed”** shall indicate the submittal has been previously reviewed and approved, is not required as a submittal, does not have evidence of being reviewed and approved by the Contractor, or is not complete. A submittal marked “Not Reviewed” shall be returned with explanation of the reason it is not reviewed. Returned submittals deemed to lack review by the Contractor or to be incomplete shall be resubmitted with appropriate action, coordination, or change.
2. Submittals marked **“Approved”** or **“Approved as Submitted”** authorize the Contractor to proceed with the work covered.

3. Submittals marked “**Approved as Noted**” authorize the Contractor to proceed with the work as noted provided the Contractor takes no exception to the notations.
4. Submittals marked “**Revise and Resubmit**” or “**Disapproved**” indicates the submittal is incomplete or does not comply with the design concept or the requirements of the Contract documents and shall be resubmitted with appropriate changes.

### **3.2 PERSONNEL AUTHORIZED TO REVIEW AND CERTIFY SUBMITTALS**

In addition to the QC Manager, the personnel listed in Exhibit 3.2 are authorized to review and certify submittals as indicated. Any additional personnel required to review and certify submittals will be submitted in writing to the Contracting Officer for approval.

### **3.3 SUBMITTAL REGISTER**

The submittal register is shown in Exhibit 3.3. The submittal register shall be maintained as follows:

1. Column (a): List each specification section in which a submittal is required.
2. Column (b): List each submittal description (SD No. and type, e.g., SD-04, Drawings) required in each specification section. Follow each submittal description with the list of material of products to be addressed in each submittal description.
3. Column (c): List one principle paragraph in the specification section where a material or product is specified. This listing is only to facilitate submittal reviews. Do not consider entries in column © as limiting project requirements; do not consider that a blank must be filled in by the Contractor or the Government.
4. Column (d): Indicates approving authority for each submittal. A “G” indicates approval by the Contracting Officer; a blank indicates approval by the Site QC Manager.
5. Column (e): Indicates for submittals to be approved by Contracting Officer, specific reviewers other than the QC organization. This column may or may not be filled out on the copy supplied by the Government.

**Columns (f) through (o) will be completed by the QC organization as follows:**

6. Column (f): As submittals are processed, list a consecutive number assigned by the Contractor for each group of submittals. Place this same number in the appropriate

block on the "Submittal Transmittal Form". For a resubmission, repeat transmittal control number of the original submittal with a suffix; e.g., No. "100B" is second resubmission of material originally transmitted under No. "100".

7. Column (g): List dates scheduled for approving authority to receive submittals. These dates are the scheduled beginnings of submittal review period. The Contractor proposes these dates and the Contracting Officer approves them to establish the approved submittal register.
8. Columns (h) and (I): Use to record Contractor's review when forwarding submittals to the QC organization.
9. Column (j): Enter date QC organization receives submittal from contractor.
10. Columns (k) and (l): If approving authority is Contracting Officer, enter date QC organization forwards certified submittal to Contracting Officer.
11. Columns (m) and (n): If approving authority is Contracting Officer, enter the Government action and date of action as shown on returned submittal. If approving authority is QC Manager, enter QC action and date of action.
12. Column (o): Enter date QC organization returns submittal to Contractor, regardless of who is approving authority. If QC Manager is approving authority, it is also the date the information is forwarded to the Government.



## **4.0 ACCREDITED LABORATORIES/TESTING LABORATORIES**

---

### **4.1 TESTING LABORATORY REQUIREMENTS**

Testing services will be provided by an independent accredited testing laboratory qualified to perform sampling and tests. When the proposed testing laboratory is not accredited by and acceptable accreditation program, as described by the paragraph entitled "Accredited Laboratories," submit to the Contracting Officer for approval, certified statements signed by an official of the testing laboratory attesting that the proposed laboratory meets or conforms to the following requirements:

1. Sampling and testing shall be under the technical direction of a registered professional engineer (PE) with at least five years of experience in sampling and testing.
2. Laboratories engaged in testing of concrete and concrete aggregates shall meet the requirements of ASTM C 1077, 1990.
3. Laboratories engaged in testing of bituminous paving materials shall meet the requirements of ASTM D 3666, 1990 (Rev. A).
4. Laboratories engaged in testing of soil and rock, as used in engineering design and construction, shall meet the requirements of ASTM D 3740, 1988.
5. Laboratories engaged in nondestructive testing (NDT)/nondestructive examination (NDE) shall meet the requirements of ASTM E 543, 1989 (Rev. A).
6. Laboratories performing work in connection with specific sampling and chemical analysis of contaminated media according to the delivery order specification shall be handled as defined in the Sampling and Analysis Plan (SAP).

### **4.2 ACCREDITED LABORATORIES**

Acceptable accreditation programs are the National Institute of Standards and Technology (NIST), National Voluntary Laboratory Accreditation Program (NVLAP), the American Association of State Highway and Transportation Officials (AASHTO) program, and the American Association for Laboratory Accreditation (AALA) program. Furnish to the Contracting Officer, a copy of the Certificate of Accreditation, Scope of Accreditation and latest directory of the accrediting organization for accredited laboratories. The scope of the laboratory's accreditation shall include the test methods required by the contract.

### **4.3 INSPECTION OF TESTING LABORATORIES**

Prior to approval of non-accredited laboratories, the proposed testing laboratory facilities and records may be subject to inspection by the Contracting Officer. Records subject to inspection include equipment inventory, equipment calibration dates and procedures, library of test procedures, audit and inspection reports by agencies conducting laboratory evaluations and certifications, testing and management personnel qualifications, test report forms, and the internal QC procedures.

### **4.4 TEST RESULTS**

Test reports shall cite applicable contract requirements, tests or analytical procedures used. Provide actual results and include a statement that the item tested or analyzed conforms or fails to conform to specified requirements. Conspicuously stamp the cover sheet for each report in large red letters "CONFORMS" or "DOES NOT CONFORM" to the specification requirements, whichever is applicable. Test results shall be signed by a testing laboratory representative authorized to sign certified test reports. Furnish the signed reports, certifications, and other documentation to the Contracting Officer via the QC Manager. The QC Manager shall furnish a summary report of field tests by attaching a copy of the report to the last daily Contractor Quality Control Report of each month.

## **5.0 TESTING PLAN AND LOG**

---

### **5.1 TESTING PLAN AND LOG**

As tests are performed, the QC Manager shall record on the "Testing Plan and Log" (Exhibit 5.1) the date the test was conducted, the date the test results were forwarded to the Contracting Officer, any remarks and acknowledgment that an accredited or Contracting Officer approved testing laboratory was used. Attach a copy of the updated testing plan and log to the last daily Contractor Quality Control Report of each month.

In development of the Testing Plan and Log, consideration shall be given to the use of multiple Testing Plans and Logs subdivided by definable features of the specification and/or of different materials within a definable feature section of the specification. When materials are tested on a specific frequency, accumulated material totals shall be recorded in the remarks section or on an attachment to each specific Testing Plan and Log to provide assurance that the tests are conducted at the required intervals.

### **5.2 TESTING**

Except as stated otherwise in the specification sections, perform sampling and testing required under the contract.

## **6.0 REWORK**

---

### **6.1 REWORK DOCUMENTATION REQUIREMENTS**

The QC Manager shall maintain a list of work that does not comply with the contract, identifying what items need to be reworked, the date the item was originally discovered, and the date the item was corrected. There is no requirement to report a rework item that is corrected the same day it is discovered. Attach a copy of the Rework Items List (Exhibit 6.1) to the last daily Contractor Quality Control Report of each month. The Contractor shall also be responsible for including on this list, items needing rework including those identified by the Contracting Officer.

## **7.0 MEETING**

---

### **7.1 COORDINATION AND MUTUAL UNDERSTANDING MEETING**

After submission of the QC Plan and prior to start of construction, meet with the Contracting Officer to discuss the QC program required for this contract. The purpose of this meeting is to develop a mutual understanding of the QC details, including forms to be used; administration of on-site and off-site work, and coordination of the Contractor's management, production and the QC Manager's duties with the Contracting Officer. A sample agenda is included as Exhibit 7.1. As a minimum, the Contractor's personnel required to attend shall include the Project Manager, Project Superintendent and QC Manager. Minutes of the meeting shall be prepared by the QC Manager and signed by both the Contractor and the Contracting Officer.

### **7.2 QC MEETINGS**

After the start of construction, the QC Manager shall conduct QC meetings once every two weeks or as required scheduled by the Contracting Officer or delivery order. The meetings will be held at the work site, or where specified, with the project superintendent and the foreman responsible for the upcoming work in attendance. The QC Manager shall take steps as may be necessary to prevent the QC Meeting from becoming a production meeting. Often it is convenient to hold a production meeting following the QC meeting, however the minutes of these meetings shall be maintained separately. The QC Manager shall notify the Contracting Officer at least 48 hours in advance of each meeting. The QC Manager shall prepare the minutes of the meeting and provide a copy to the Contracting Officer within two working days after the meeting. As a minimum, the following shall be accomplished at each meeting:

1. Review the minutes of the previous meeting.
2. Review the schedule and the status of work.
  - Work or testing accomplished since last meeting.
  - Rework items identified since last meeting.
  - Rework items completed since last meeting.
3. Review the status of submittals.
  - Submittals reviewed and approved since last meeting.

- Submittals required in the near future.
4. Review the work to be accomplished in the next two weeks and documentation required. Schedule the three phases of control and testing:
    - Establish completion dates for rework items.
    - Identify Preparatory Phases required.
    - Identify Initial Phases required.
    - Identify Follow-up Phases required.
    - Identify Testing required.
    - Identify status of off-site work or testing.
    - Identify documentation required.
  5. Resolve QC and production problems.
  6. Address items that may require revising the QC plan such as or changes in procedures.

In addition to the normal project distribution which includes the Contracting Officer, a copy shall be forwarded to the C.O.T.R., LANTDIV, the Program QC Manager, and the OHM Program Manager.

## **8.0 THREE PHASES OF CONTROL**

---

The QC Manager shall perform the three phases of control to ensure that work complies with contract requirements. The three phases of control shall adequately cover both on-site and off-site work and shall include the Inspection Plan activities (see Exhibit 8.0) of each definable feature of work as listed in Exhibit 9.1.

### **8.1 PREPARATORY PHASE**

Notify the Contracting Officer at least two working days in advance of each preparatory phase. Conduct the preparatory phase meeting with the superintendent and the foreman responsible for the definable feature of work. Document the results of the preparatory phase actions in the daily Contractor Quality Control Report (Exhibit 8.1). Perform the following prior to beginning work on each definable feature of work:

- Review each paragraph of the applicable specification sections.
- Review the contract drawings.
- Verify that appropriate shop drawings and submittals for materials and equipment have been submitted and approved. Verify receipt of approved factory test results, when required.
- Review the testing plan and ensure that provisions have been made to provide the required QC testing.
- Examine the work area to ensure that the required preliminary work has been completed.
- Examine the required materials, equipment and sample work to ensure that they are on hand and conform to the approved shop drawings and submitted data.
- Review the safety plan and appropriate activity hazard analysis to ensure that applicable safety requirements are met, and that required Material Safety Data Sheets (MSDS) are submitted.
- Discuss construction methods.

### **8.2 INITIAL PHASE**

Notify the Contracting Officer at least two working days in advance of each initial phase meeting. When crews are ready to start work on an a definable feature of work, conduct the initial phase meeting with the personnel responsible for that definable feature of work. Observe the initial segment of the definable feature of work to ensure that the work complies with contract requirements. Document the results of the initial phase in the daily Contractor Quality Control Report. Repeat the initial phase for changes in personnel assigned

responsibility for the work, or when acceptable levels of specified quality are not being met. Perform the following for each definable feature of work:

- Establish the quality of workmanship required.
- Resolve conflicts.
- Review the Safety Plan and the appropriate activity hazard analysis to ensure that applicable safety requirements are met.
- Ensure that testing is performed.

### **8.3 FOLLOW-UP PHASE**

Perform the following for ongoing work daily, or more frequently as necessary, until the completion of each definable feature of work and document in the daily Contractor Quality Control Report:

- Ensure the work is in compliance with contract requirements.
- Maintain the quality of workmanship required.
- Ensure that testing is performed.
- Ensure that rework items are being corrected.

### **8.4 NOTIFICATION OF THREE PHASES OF CONTROL FOR OFF-SITE WORK**

Notify the Contracting Officer at least two weeks prior to the start of the preparatory and initial phases.

### **8.5 RECEIPT INSPECTION**

The QC organization shall conduct Receipt Inspection of materials and equipment procured in accordance with the delivery order specification. In addition to the submittal documentation, which will be reviewed and approved as required under Section 3.0, Submittals, the following attributes will be inspected for each order/shipment as applicable:

- Material is same as specified by the Delivery Order Specification
- Quantity as specified by the procurement document
- Dimensions as required by the procurement document
- Shipping Damage
- Physical Damage
- Identification and Marking
- Protective Covers and Seals
- Cleanliness
- Workmanship



Materials and equipment found to be unacceptable at receipt inspection shall be rejected and "RED Tagged" (see Exhibit 8.5) until correction or replacement can be made. This material/equipment shall not be used until the corrective action results in satisfactory reinspection.

The results of the receipt inspection, by attribute, will be included in the Contractor Quality Control Report (Exhibit 8.1) for the date of inspection.

## **8.6 DOCUMENTATION**

Reports are required for each day that work is performed and for every seven consecutive calendar days of no work and on the last day of no work periods. Account for each calendar day throughout the life of the contract. The reporting of work shall be identified by terminology consistent with the construction schedule. Contractor Quality Control Reports are to be prepared, signed and dated by the QC Manager and shall contain the following information:

- Identify the control phase and the definable feature of work.
- Results of the preparatory phase meetings held, including the location of the definable feature of work and a list of personnel present at the meeting. Indicate in the report that for this definable feature of work, the drawings and specifications have been reviewed, submittals have been approved, materials comply with approved submittals, materials are stored properly, preliminary work was done correctly, the testing plan has been reviewed, and work methods and schedules have been discussed.
- Results of the initial phase meetings held, including the location of the definable features of work and a list of personnel present at the meeting. Indicate in the report that for this definable feature of work, the preliminary work was done correctly, samples have been prepared and approved, the workmanship is satisfactory, test results are acceptable, work is in compliance with the contract, and the required testing has been performed and include a list of who performed the tests.
- Results of the follow-up phase inspections held, including the location of the definable features of work. Indicate in the report that for this definable feature of work that the work complies with the contract as approved and that required testing has been performed and include a list of who performed the tests.
- Results of the three phases of control for off-site work, if applicable, including actions taken.
- List the rework items identified, but not corrected by close of business.
- As rework items are corrected, provide a revised rework items list along with the corrective action taken.

- Include in the remarks section of the report pertinent information including directions received, quality control problem areas, deviations from the QC Plan, construction deficiencies encountered, QC meetings held, acknowledgment that as-built drawings have been updated, corrective direction given by the QC Manager and corrective action taken by the contractor.
- When the QC Manager believes that an attribute list type inspection is more appropriate for the inspection of specific definable features of work, he/she may use any type of form desired for this purpose. However, this or any other form utilized shall become an attachment to the daily Contractor Quality Control Report and shall not preclude any other requirements of the contract or this plan.

## **9.0 *DEFINABLE FEATURES OF WORK***

---

### **9.1 *DEFINABLE FEATURES OF WORK***

Exhibit 9.1 contains a list of definable features of work for this delivery order. A definable feature of work is a task that is separate and distinct from other tasks and requires separate control requirements. As a minimum, each division of the specification is considered a definable feature of work. However, at times there may be more than one definable feature of work in each division of the specification or a definable feature of work may include several specification sections. The QC Manager shall discuss the list with the Contracting Officer for possible expansion of the list.

## **10.0 EXHIBITS**

---

The following forms are acceptable for providing the information required by this QC Plan and the contract, except as otherwise directed by the Contracting Officer. While use of these specific forms are not required by the contract, any other format used shall contain the same information and be approved by the Program QC Manager. Exhibit 10.1 includes additional forms used by the contractor. These forms and their use are not addressed in this QC Plan.

NOTE: Exhibit numbers refer to the paragraph from which the Exhibit was first addressed.

### **10.1 INDEX OF EXHIBITS**

Exhibit 2.1	Organizational Chart
Exhibit 2.2	Project QC Manager's Resume (TBN)
Exhibit 2.4	Project QC Manager Appointment Letter
Exhibit 3.1	Submittal Descriptions (SD)
Exhibit 3.2	List of Personnel Authorized to Review and Certify Submittals
Exhibit 3.3	Submittal Register
Exhibit 5.1	Testing Plan and Log
Exhibit 6.1	Rework Items List
Exhibit 7.1	Sample agenda for the Coordination and Mutual Understanding Meeting
Exhibit 8.0	Inspection Schedule
Exhibit 8.1	Contractor Quality Control Report
Exhibit 8.5	Reject Tag (RED Tagged)
Exhibit 9.1	Definable Features of Work
Exhibit 10.1	Contractor Forms

**Exhibit 2.1**

**QC Organization Chart**

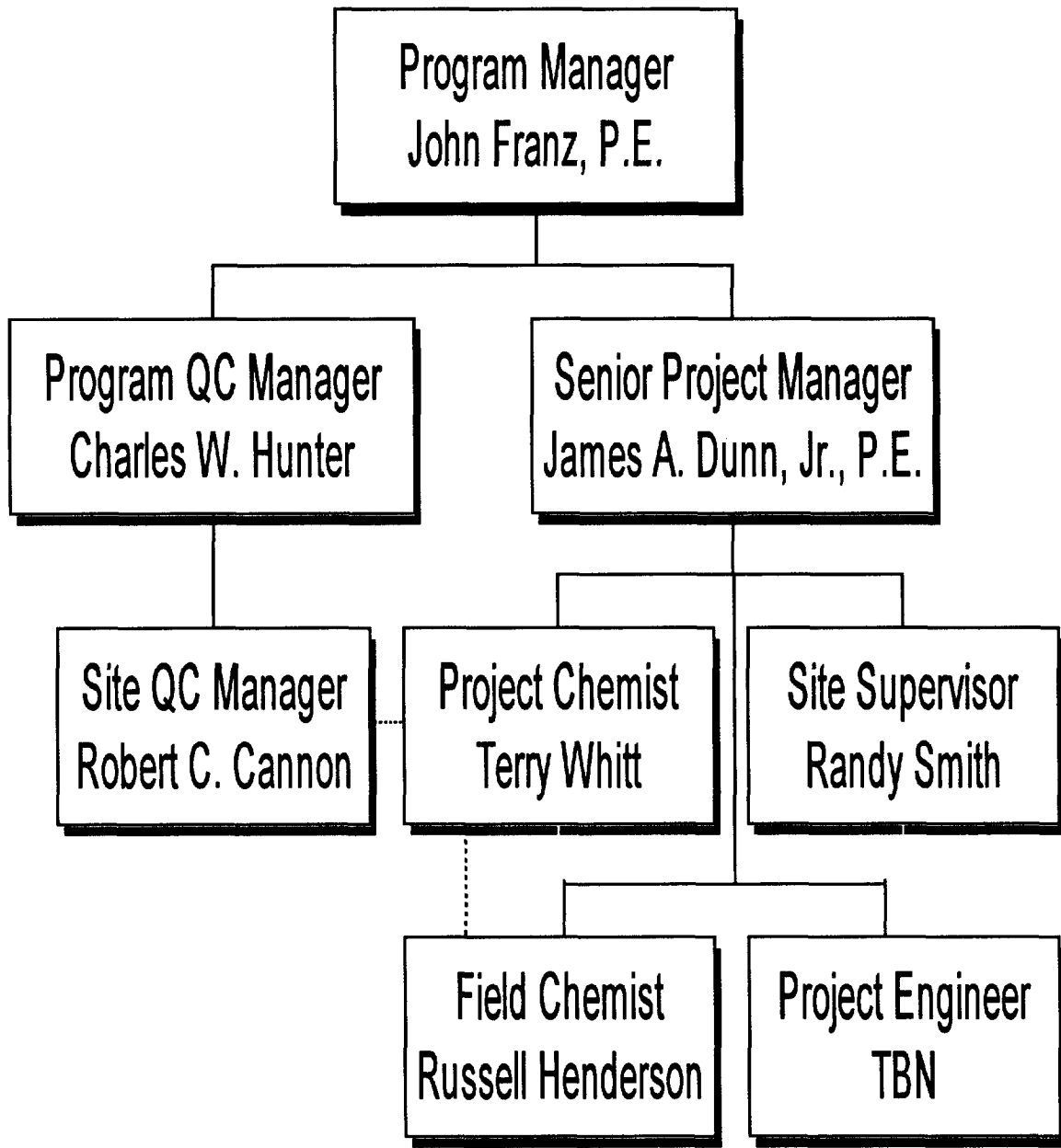

## Exhibit 2.4



**OHM Remediation  
Services Corp.**

A Subsidiary of OHM Corporation

August 20, 1998

Mr. Robert C. Cannon  
IT/OHM Remediation Services Corp.  
200 Horizon Center Blvd.  
Trenton, NJ 08691-1904

**Re: *Site QC Manager***  
***MCB Camp LeJeune, North Carolina (Contract N62470-93-D-3032)***  
***Delivery Order 0175***

Dear Robert:

This letter will serve as your appointment as the Site Quality Control Manager on the referenced project and will also clarify your duties and authority in this position. In this position, you will be authorized to use available resources to satisfy all applicable requirements of the Program and Delivery Order Quality Control Plans.

This authorization specifically gives you the authority to direct removal and replacement or correction of nonconforming materials or work and stop work authority when continuation would be unsafe to personnel, harmful to the environment, or result in a significant degradation of quality.

You will be expected to work closely with the Project Manager, Site Supervisor and other project personnel, but you will not be directly responsible to anyone but myself for resolution of quality issues when working in the capacity of Quality Control Manager.

If you have any questions regarding this matter, please call me at (609) 584-6840.

Sincerely,

C. W. Hunter  
Program QC Manager  
LANTDIV RAC Program

## **Exhibit 3.1**

### **Submittal Descriptions**

#### ***SD-01, Data***

Submittals that provide calculations, descriptions, or other documentation regarding the work.

#### ***SD-02, Manufacturer's Catalog Data***

Data composed of catalog cuts, brochures, circulars, specifications and product data, printed information in sufficient detail and scope to verify compliance with requirements of the contract documents. A type of product data.

#### ***SD-03, Manufacturer's Standard Color Charts***

Preprinted illustrations displaying choices of color and finish for a material or product. A type of product data.

#### ***SD-04, Drawings***

Submittals that graphically show relationship of various components of the work, schematic diagrams of systems detail of fabrications, layout of particular elements, connections, and other relational aspects of the work. A type of shop drawing.

#### ***SD-05, Design Data***

Design calculations, mix design, analyses, or other data written in nature and pertaining to a part of the work. A type of shop drawings.

#### ***SD-06, Instructions***

Preprinted material describing installation of a product, system, or material, including special notices and Material Safety Data Sheets, if any, concerning impedances, hazards, and safety precautions. A type of product data.

#### ***SD-07, Schedules***

A tabular list of data or tabular list including location, features, or other pertinent information regarding products, materials, equipment, or components to be used in the work. A type of shop drawing.

#### ***SD-08, Statements***

A document, required of the Contractor, or through the Contractor by way of a supplier, installer, manufacturer, or other lower tier contractor, the purpose of which is to further the quality or orderly progression of a portion of the work by documenting procedures, acceptability of method or personnel, qualifications, or other verification of quality. A type of shop drawing.

#### ***SD-09, Reports***

Reports of inspection and laboratory test, including analysis and interpretation of test results. Each report shall be properly identified. Test method used and compliance with recognized test standards shall be described.

#### ***SD-10, Test Reports***

A report signed by an authorized official of a testing laboratory that a material, product, or system identified to the material, product or system to be provided has been tested in accordance with requirements specified by naming the test method and material. The test report must state the test

was performed in accordance with the test requirements; state the test results; and indicate whether the material, product, or system has passed or failed the test. Testing must have been within three years of the date of Contract award. A type of product data.

***SD-11, Factory Test Reports***

A written report that includes the findings of a test required to be performed by the Contractor on an actual portion of the work or prototype prepared for this project before it is shipped to the job site. The report must be signed by an authorized official of a testing laboratory and must state the test was performed in accordance with the test requirements; state the test results; and indicate whether the material, product or system has passed or failed the test. A type of shop drawing.

***SD-12, Field Test Results***

A written report that includes the findings of a test made at the job site, in the vicinity of the job site, or on a sample taken from the jobsite, on a portion of the work, during or after installation. The report must be signed by an authorized official of a testing laboratory or agency and must state the test was performed in accordance with the test requirements; state the test results; and indicate whether the material, product, or system has passed or failed the test. A type of shop drawing.

***SD-13, Certificates***

Statements signed by responsible officials of a manufacturer or a product, system or material attesting that the product, system, or material meet specified requirements. The statements must be dated after the award of this contract, name the project, and list the specific requirements that it is intended to address. A type of shop drawing.

***SD-14, Samples***

Samples, including both fabricated and unfabricated physical examples of materials, products, and units of work as complete units or as portions of units of work. A type of sample.

***SD-15, Color Selection Samples***

Samples of the available choice of colors, textures, and finishes of a product or material, presented over substrates identical in texture to that proposed for the work. A type of sample.

***SD-16, Sample Panels***

An assembly constructed at the product site in a location acceptable to the Contracting Officer and using materials and methods to be employed in the work; completely finished; maintained during construction; and removed at the conclusion of the work or when authorized by the Contracting officer. A type of sample.

***SD-17, Sample Installations***

A portion of an assembly or material constructed where directed and, if approved, retained as a part of the work. A type of sample.

***Sd-18, Records***

Documentation to ensure compliance with an administrative requirement or to establish an administrative mechanism. A type of administrative and close-out submittal.

***SD-19, Operation and Maintenance Manuals***

Data intended to be incorporated in an operations and maintenance manual. A type of administrative and close-out submittal.



## Exhibit 3.2

### List of Personnel Authorized to Review and Certify Submittals

Specification Section	Submittal Type	Authorized Personnel
01110, 01115, 01430, 01575, 0222, 02231, 02315	All Others	Randy Smith Jim Dunn Fred Haas  LANTDIV RPM

**Submittal Register**  
**OU 1 Site 78, MCB Camp Lejeune, North Carolina**

Spec. No.	SD No. and Type of Submittal Material or Product	Spec. Para. No.	Approval by CO	Gov. or A/E Reviewer	Trans. Control No.	Planned Sub. Date	Action Code	Date of Action	Date Forwarded to Appro. Auth./Date Received from Contr.	Date Forwarded to Other Reviewer	Date Received from Other Reviewer	Action Code	Date of Action	Mailed to Contr./Recd. from Appro. Auth.	Remarks
a	b	c	d	e	f	g	h	i	j	k	l	m	n	o	p
01115	SD-09 Reports														
	Work Plan	1.2.1.1													
	Health & Safety Plan														
	QA/QC Plan														
	T&D Plan														
	Erosion & Sediment Control Plan														
0222	SD-08 Statements														
	Field Sampling and Laboratory Testing Plan	1.1.3.1.2													
02315	SD-04 Drawings														
	Drawings	1.3.1.1													
	SD-05 Design Data														
	Calculations	1.3.2.1													
02315	SD-12 Field Test Reports														
	Fill and Backfill	3.12.2.1													
02821	SD-02 Mfgr's Catalog Data														
	Chain-link fencing	2.1													
	Accessories	2.1.4													
02900	Well Casing	2.2.1													
	Well Screen	2.2.1													
02900	Well Casing	2.2.1													

CR - Closeout Report  
 WP - Work Plan  
 A - Approved  
 AN - Approved as noted

**Submittal Register**  
**OU 1 Site 78, MCB Camp Lejeune, North Carolina**

Spec. No.	SD No. and Type of Submittal Material or Product	Spec. Para. No.	Approval by CO	Gov. or A/E Reviewer	Trans. Control No.	Planned Sub. Date	Action Code	Date of Action	Date Forwarded to Appro. Auth./Date Received from Contr.	Date Forwarded to Other Reviewer	Date Received from Other Reviewer	Action Code	Date of Action	Mailed to Contr./Recd. from Appro. Auth.	Remarks
	Well Screen	2.2.1													
02905	SD-02 Mfgr's Catalog Data														
	Well Casing														
	Well Screen														
	Header Piping														
	Well Vaults														
	SD-19 O&M Manuals														
	Operation & Maintenance Manuals														
02921	SD-02 Mfgr's Catalog Data														
03300	SD-05 Design Data														
	Concrete Mix Designs	2.1													
	SD-10 Test Reports														
	Compressive Strength Tests	1.2													

CR - Closeout Report  
 WP - Work Plan  
 A - Approved  
 AN - Approved as noted





**SAMPLE DOCUMENT**

**COORDINATION AND MUTUAL UNDERSTANDING MEETING AGENDA  
FOR  
DELIVERY ORDER No.0013  
SITE 85 CAMP JOHNSON BATTERY DUMP AT THE  
MARINE CORPS BASE  
CAMP LEJEUNE, NORTH CAROLINA  
\_\_\_\_\_, 1998**

The purpose of this meeting is to develop a mutual understanding of the QC details, including forms to be used; administration of on-site and off-site work, and coordination of the Contractor's management, production and the QC Manager's duties with the Contracting Officer.

The QC program consists of a QC Organization, QC Manager, a QC Plan for this Delivery Order, this Coordination and Mutual Understanding Meeting, QC meetings, three phases of control, submittal review, submittal approval except for submittals designated for Contracting Officer approval, testing, and QC certifications and documentation necessary to provide materials, equipment, workmanship, fabrication, construction and operations which comply with requirements of this contract.

Project QC Manager duties (contract para. 6.6.1)

- Attend this meeting
- Conduct the QC Meetings
- Perform the three phases of control
- Perform submittal review
- Perform submittal approval
- Ensure testing is performed
- Prepare QC certifications and documentation
- Perform other activities when approved by the Contracting Officer

Submittal Reviewers Duties and Qualifications (contract para. 6.7)

- Provide submittal reviewers qualified in the disciplines being reviewed other than the QC Manager, to review and certify that the submittals meet the requirements of the contract.

QC Plan (contract para. 6.8)

- (as specified therein)

Coordination and Mutual Understanding Meeting (contract para. 6.9)

- (see purpose above)

QC meetings (contract para. 6.10)

- The QC Manager shall conduct QC meetings once every two weeks or as otherwise directed by the Contracting Officer.

- Meeting minutes to be prepared by the QC Manager in accordance with the contract outline and a copy provided to the Contracting Officer within two working days of the meeting.
- A copy will be distributed to the Program QC Manager.

Three phases of control (contract para. 6.11)

- Preparatory Phase Meeting
- Initial Phase Meeting
- Follow-Up Phase Inspection

Submittal review and approval (contract para. 6.12 and Part 7.0, "Submittals")

- Review
- Approval
- Certification
- Submittal Register

Testing (contract para. 6.13)

- - Testing Laboratory Requirements
- Accredited Laboratories
- Inspection and Testing Laboratories
- Capability Checks
- Test Results

QC certifications (contract para. 6.14)

- Contractor Quality Control Report Certification
- Invoice Certification
- Completion certification

Documentation (contract para. 6.15)

- Contractor Production Report
- Contractor Quality Control Report
- Testing Plan and Log
- Rework Items List
- As-Built Records
- Report Forms
- Contractor Production Report
- Contractor Quality Control Report
- Testing Plan and Log
- Rework Items List

**Exhibit 8.0**  
**Inspection Schedule**  
 OU 1 Site 78  
 MCB Camp Lejeune, North Carolina  
 Delivery Order No. 0175

Spec Section	Activity*	Preparatory Report No.	Initial Report No.	Follow-Up Report Nos.**
	<p><u>Site Preparation</u></p> <ul style="list-style-type: none"> <li>- Establish lines and grades</li> <li>- Establish well locations, jack and bore, trenching, and equip. laydown area</li> <li>- Utility clearances</li> <li>- Security Fencing</li> <li>- Erosion and sediment controls (silt fence &amp; diversion berms)</li> <li>- Establish work zones</li> <li>- Establish personnel décor area</li> </ul> <p><u>Well &amp; Well Vault Construction</u></p> <ul style="list-style-type: none"> <li>- Drill and Bore</li> <li>- Install well casing and construction</li> <li>- Well vault installation</li> </ul>			

\*Also include scheduled date if a CPM network is invoked. \*\* Includes first and final inspections only.



**Exhibit 8.0**  
**Inspection Schedule**  
 OU 1 Site 78  
 MCB Camp Lejeune, North Carolina  
 Delivery Order No. 0175

Spec Section	Activity*	Preparatory Report No.	Initial Report No.	Follow-Up Report Nos.**
	<u>Pipe Trench</u> - Excavation limits - Pipe installation - Pressure Testing - Backfill & compaction  <u>Well Abandonment</u>  <u>T &amp; D Well Cuttings</u>  <u>Well Development &amp; Startup</u>  <u>Groundwater Sampling &amp; Analysis</u>  <u>Site Restoration</u> - Asphalt placement - Seeding & mulching  <u>Maintenance &amp; Operation</u>			

\*Also include scheduled date if a CPM network is invoked. \*\* Includes first and final inspections only.

**Quality Control Plan Review**  
 OU 1 Site 78  
 MCB Camp Lejeune, North Carolina  
 Delivery Order No. 0175

By signing this document, I am stating that I have read and understand the site Quality Control Plan for this Delivery Order/Project.  
 Any questions or comments should be addressed to either the Program or site QC Manager.

<i>Name (Print)</i>	<i>Signature</i>	<i>Title</i>	<i>Company</i>	<i>Date</i>
Charles W. Hunter		QC Manager		
James Dunn, Jr.		Project Manager		
Randy Smith		Project Superintendent		
Paul Matz		Project Engineer		
		Project General Foreman		
		Project Foreman		
Allison Harwood		Site Safety Officer		
Robert Cannon		Site QC Manager		

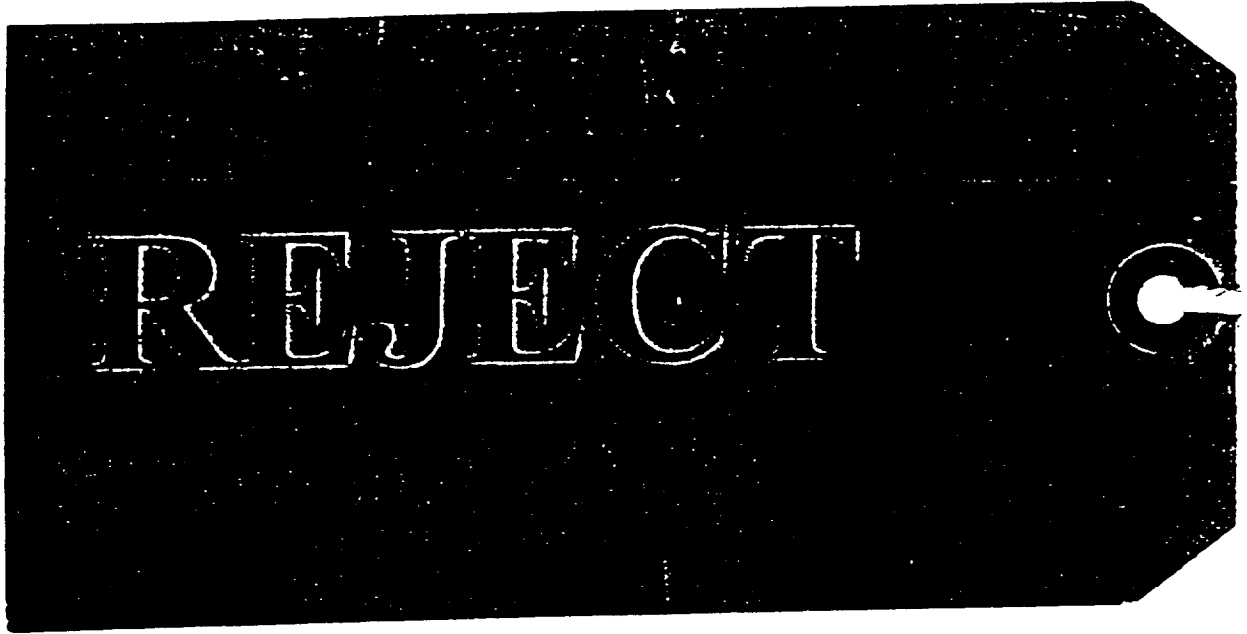

REJECT

**Definable Features of Work  
OU 1 Site 78, MCB Camp Lejeune, North Carolina**

Specification Section:	Definable of Feature of Work:
01115, 02315	Site Preparation
01115, 02900, 02905	Well Installation
01115, 02905	Piping Installations
01115, 15700, 16303, 16402	System Startup
01115, 02821	Site Restoration

<b>CONTRACTOR QUALITY CONTROL REPORT</b> (ATTACH ADDITIONAL SHEETS IF NECESSARY)			DATE
PHASE	Y - YES, N - NO, SEE REMARKS, BLANK - NOT APPLICABLE	IDENTIFY DEFINABLE FEATURE OF WORK LOCATION AND LIST PERSONNEL PRESENT	
<b>PREPARATORY</b>	THE PLANS AND SPECS HAVE BEEN REVIEWED		
	THE SUBMITTALS HAVE BEEN APPROVED		
	MATERIALS COMPLY WITH APPROVED SUBMITTALS		
	MATERIALS ARE STORED PROPERLY		
	PRELIMINARY WORK WAS DONE CORRECTLY		
	TESTING PLAN HAS BEEN REVIEWED		
	WORK METHOD AND SCHEDULE DISCUSSED		
<b>INITIAL</b>	PRELIMINARY WORK WAS DONE CORRECTLY		TESTING PERFORMED & WHO PERFORMED TEST
	SAMPLE HAS BEEN PREPARED/APPROVED		
	WORKMANSHIP IS SATISFACTORY		
	TEST RESULTS ARE ACCEPTABLE		
	WORK IS IN COMPLIANCE WITH THE CONTRACT		
<b>FOLLOW-UP</b>	WORK COMPLIES WITH CONTRACT AS APPROVED IN INITIAL PHASE		TESTING PERFORMED & WHO PERFORMED TEST
REWORK ITEMS IDENTIFIED (NOT CORRECTED BY CLOSE OF BUSINESS)		REWORK ITEMS CORRECTED TODAY (FROM REWORK ITEMS LIST)	
REMARKS			
<p>On behalf of the contractor, I certify that this report is complete and equipment and material used and work performed during this reporting period is in compliance with the contract drawings and specifications to the best of my knowledge except as noted in this report.</p> <div style="display: flex; justify-content: space-between;"> <span>_____ AUTHORIZED QC MANAGER AT SITE</span> <span>_____ DATE</span> </div>			
<b>GOVERNMENT QUALITY ASSURANCE REPORT</b>			DATE
QUALITY ASSURANCE REPRESENTATIVE'S REMARKS AND/OR EXCEPTIONS TO THE REPORT			

CONTRACTOR QUALITY CONTROL REPORT CONTINUATION SHEET (ATTACH ADDITIONAL SHEETS IF NECESSARY)			DATE
CONTRACT NO.			REPORT NO.
PHASE	Y - YES, N - NO, SEE REMARKS, BLANK - NOT APPLICABLE	IDENTIFY DEFINABLE FEATURE OF WORK LOCATION AND LIST PERSONNEL PRESENT	
PREPARATORY	THE PLANS AND SPECS HAVE BEEN REVIEWED		
	THE SUBMITTALS HAVE BEEN APPROVED		
	MATERIALS COMPLY WITH APPROVED SUBMITTALS		
	MATERIALS ARE STORED PROPERLY		
	PRELIMINARY WORK WAS DONE CORRECTLY		
	TESTING PLAN HAS BEEN REVIEWED		
	WORK METHOD AND SCHEDULE DISCUSSED		
PHASE	Y - YES, N - NO, SEE REMARKS, BLANK - NOT APPLICABLE	IDENTIFY DEFINABLE FEATURE OF WORK LOCATION AND LIST PERSONNEL PRESENT	
INITIAL	PRELIMINARY WORK WAS DONE CORRECTLY		TESTING PERFORMED & WHO PERFORMED TEST
	SAMPLE HAS BEEN PREPARED/APPROVED		
	WORKMANSHIP IS SATISFACTORY		
	TEST RESULTS ARE ACCEPTABLE		
	WORK IS IN COMPLIANCE WITH THE CONTRACT		

**CONTRACTOR QUALITY CONTROL REPORT CONTINUATION SHEET**

(ATTACH ADDITIONAL SHEETS IF NECESSARY)

DATE

CONTRACT NO.

REPORT NO.

PHASE Y - YES, N - NO, SEE REMARKS,  
BLANK - NOT APPLICABLE

IDENTIFY DEFINABLE FEATURE OF WORK LOCATION AND LIST PERSONNEL PRESENT

WORK COUPLES WITH  
CONTRACT AS APPROVED  
IN INITIAL PHASE

TESTING PERFORMED &  
WHO PERFORMED TEST

FOLLOW-UP

Exhibit 10.1a

<b>CONTRACTOR PRODUCTION REPORT</b> (ATTACH ADDITIONAL SHEETS IF NECESSARY)			DATE		
CONTRACT NO.	TITLE AND LOCATION		REPORT NO.		
CONTRACTOR		SUPERINTENDENT			
AM WEATHER	PM WEATHER	MAX TEMP °F	MIN TEMP °F		

WORK PERFORMED TODAY				
WORK LOCATION AND DESCRIPTION	EMPLOYER	NUMBER	TRACE	HRS

<b>JOB SAFETY</b>	WAS A JOB SAFETY MEETING HELD THIS DATE? <input type="checkbox"/> YES <input type="checkbox"/> NO (If YES, attach copy of the meeting minutes)	TOTAL WORK HOURS ON JOB SITE THIS DATE
	WERE THERE ANY LOST TIME ACCIDENTS THIS DATE? <input type="checkbox"/> YES <input type="checkbox"/> NO (If YES, attach copy of completed OSHA report)	CUMULATIVE TOTAL OF WORK HOURS FROM PREVIOUS REPORT
	WAS TRENCHING/SCAFFOLD/HV ELECTRICAL/HIGH WORK DONE? <input type="checkbox"/> YES <input type="checkbox"/> NO (If YES, attachment statement or checklist showing inspection performed)	TOTAL WORK HOURS FROM START OF CONSTRUCTION
	WAS HAZARDOUS MATERIAL/WASTE RELEASED INTO THE ENVIRONMENT? <input type="checkbox"/> YES <input type="checkbox"/> NO (If YES, attach description of incident and proposed action)	
LIST SAFETY ACTIONS TAKEN TODAY/SAFETY INSPECTIONS CONDUCTED		SAFETY REQUIREMENTS HAVE BEEN MET

EQUIPMENT MATERIAL RECEIVED TODAY TO BE INCORPORATED IN JOB

CONSTRUCTION AND PLANT EQUIPMENT ON JOB SITE TODAY INCLUDE NUMBER OF HOURS USED TODAY

REMARKS

\_\_\_\_\_  
CONTRACTOR/SUPERINTENDENT      DATE





OHM Remediation Services Corp.

Exhibit 10.1b

Routing: Contr. Adm.

Proj. Mgr  
Site Supv.  
Proj. Acct.  
CSE  
QC  
Job File

Project Name: \_\_\_\_\_  
Delivery Order: \_\_\_\_\_  
Contract Purchase Order N62470-93-D-3032  
OHM Project Order \_\_\_\_\_

\_\_\_\_\_  
\_\_\_\_\_  
\_\_\_\_\_

OVERTIME AUTHORIZATION (OTA)

Date of Request: \_\_\_\_\_ WBS Code: \_\_\_\_\_ OTA No: \_\_\_\_\_

Reason for request	Explanation: _____
<input type="checkbox"/> Emergency	_____
<input type="checkbox"/> Equipment Maintenance	_____
<input type="checkbox"/> Keep critical activities on schedule	_____
<input type="checkbox"/> Accelerate schedule	_____
<input type="checkbox"/> Other	_____
Initiated by: _____	_____
<input type="checkbox"/> Navy	_____
<input type="checkbox"/> OHM	_____
<input type="checkbox"/> Other	_____

Estimated period of overtime work \_\_\_\_\_ Start Date: \_\_\_\_\_  
End Date: \_\_\_\_\_  
ROM Cost Estimate \_\_\_\_\_

Requested By: \_\_\_\_\_  
Date: \_\_\_\_\_  
OHM Project Manager

APPROVALS

Approved                       Modified                       Rejected

Modification (if any)

\_\_\_\_\_

\_\_\_\_\_

\_\_\_\_\_

RPM: \_\_\_\_\_  
Date: \_\_\_\_\_  
ROICC/NTR: \_\_\_\_\_  
Date: \_\_\_\_\_



OHM Remediation  
Services Corp.

Exhibit 10.1c

Routing: Contr. Adm.  
Site Supv.  
Proj. Acct.  
CSE  
QC  
Job File

Project Name: \_\_\_\_\_  
Delivery Order: \_\_\_\_\_  
Contract Purchase Order N62470-93-D-3032  
OHM Project Order \_\_\_\_\_

\_\_\_\_\_  
\_\_\_\_\_  
\_\_\_\_\_

REQUEST FOR INFORMATION (RFI)

Date of Request: \_\_\_\_\_ Suspense Date: \_\_\_\_\_ VR No: \_\_\_\_\_

SITUATION/CONDITION      Dwg Ref: \_\_\_\_\_      Spec Sec: \_\_\_\_\_  
REQUIRING CLARIFICATION      Site Location \_\_\_\_\_

DESCRIPTION:  
\_\_\_\_\_  
\_\_\_\_\_  
\_\_\_\_\_  
\_\_\_\_\_  
\_\_\_\_\_  
\_\_\_\_\_  
\_\_\_\_\_  
\_\_\_\_\_  
\_\_\_\_\_  
\_\_\_\_\_

DATE RECEIVED BY:  
Certifying Engineer: \_\_\_\_\_ Tech. Rep: \_\_\_\_\_ ROICC: \_\_\_\_\_

RESPONSE:  
\_\_\_\_\_  
\_\_\_\_\_  
\_\_\_\_\_  
\_\_\_\_\_

Note: This is a clarification and does not create additional work that could be considered as a change to the contract drawings and /or specification.

RPM: \_\_\_\_\_ Date: \_\_\_\_\_

ROICC/NTR: \_\_\_\_\_ Date: \_\_\_\_\_



**OHM Remediation  
Services Corp.**

Exhibit 10.1d

Routing: Contr. Adm.  
Site Supv.  
Proj. Acct.  
CSE  
QC  
Job File

Project Name: \_\_\_\_\_  
Delivery Order: \_\_\_\_\_  
Contract Purchase Order N62470-93-D-3032  
OHM Project Order \_\_\_\_\_

\_\_\_\_\_  
\_\_\_\_\_  
\_\_\_\_\_

**VARIANCE REQUEST (VR)**

Date of Request: \_\_\_\_\_ Suspense Date: \_\_\_\_\_ VR No: \_\_\_\_\_

**PROPOSED VARIANCE**      Dwg Ref.: \_\_\_\_\_ Spec Sec: \_\_\_\_\_  
Site Location \_\_\_\_\_

**DESCRIPTION:**  
\_\_\_\_\_  
\_\_\_\_\_  
\_\_\_\_\_  
\_\_\_\_\_

Note: Approval of this variance will not result in an increase in cost or in time of performance to this contract.  
Initiated By  Navy  
                   OHM  
                   Regulatory Agency  
                   Other

On-Site Engineer: \_\_\_\_\_ Date: \_\_\_\_\_  
OHM Project Engineer \_\_\_\_\_ Date: \_\_\_\_\_  
Site Quality Control Manager: \_\_\_\_\_ Date: \_\_\_\_\_  
OHM Project Manager: \_\_\_\_\_ Date: \_\_\_\_\_

**APPROVALS**                       Approved     Modified (see below)     Rejected

\_\_\_\_\_  
\_\_\_\_\_

Note: This is a clarification and does not create additional work that could be considered as a change to the cost of the project.

RPM: \_\_\_\_\_ Date: \_\_\_\_\_  
ROICC/NTR: \_\_\_\_\_ Date: \_\_\_\_\_

