

04.08-08/01/93-01483

Final

**Feasibility Study for
Operable Unit No. 2
(Sites 6, 9, and 82)**

**Marine Corps Base, Camp Lejeune,
North Carolina**



Prepared For:

**Department of the Navy
Atlantic Division
Naval Facilities
Engineering Command
Norfolk, Virginia**

Under the

LANTDIV CLEAN Program

**Comprehensive Long-Term
Environmental Action Navy**

TABLE OF CONTENTS

	<u>Page</u>
LIST OF ACRONYMS AND ABBREVIATIONS	vi
EXECUTIVE SUMMARY	ES-1
1.0 INTRODUCTION	1-1
1.1 Purpose and Organization of Report	1-2
1.1.1 Purpose of the Feasibility Study	1-2
1.1.2 Report Organization	1-3
1.2 Site Background Information	1-4
1.2.1 Site Description	1-4
1.2.2 Site History	1-10
1.2.3 Investigation and Study History	1-12
1.2.4 Nature and Extent of Contamination	1-16
2.0 DEVELOPMENT OF REMEDIAL ACTION OBJECTIVES	2-1
2.1 Contaminants of Concern	2-1
2.2 Routes of Exposure and Receptors	2-3
2.3 Preliminary Remediation Goals	2-3
2.3.1 Applicable or Relevant and Appropriate Federal and State Requirements	2-3
2.3.2 Potential ARARs Identified for Operable Unit No. 2	2-5
2.3.3 Site-Specific Risk-Based Action Levels	2-14
2.3.4 Summary of Remediation Goals and COCs	2-45
2.3.5 Areas of Concern Requiring Remediation	2-49
2.4 Remedial Action Objectives	2-51
3.0 IDENTIFICATION AND PRELIMINARY SCREENING OF REMEDIAL TECHNOLOGIES	3-1
3.1 General Response Actions	3-1
3.1.1 No Action	3-1
3.1.2 Institutional Controls	3-1
3.1.3 Containment Actions	3-3
3.1.4 Collection/Treatment Actions	3-3
3.1.5 Excavation/Treatment Actions	3-3
3.2 Identification of Remedial Action Technologies and Process Options ..	3-3
3.3 Preliminary Screening of Remedial Action Technologies and Process Options	3-4
3.4 Process Option Evaluation	3-18
4.0 DEVELOPMENT AND SCREENING OF ALTERNATIVES	4-1
4.1 Development of Alternatives	4-1
4.1.1 Groundwater RAAs	4-4
4.1.2 Soil RAAs	4-18
4.2 Screening of Alternatives	4-45

TABLE OF CONTENTS (Continued)

	<u>Page</u>
5.0 DETAILED ANALYSIS OF ALTERNATIVES	5-1
5.1 Individual Analysis of Alternatives	5-1
5.1.1 Groundwater RAAs	5-2
5.1.2 Soil RAAs	5-16
5.2 Comparative Analysis	5-35
5.2.1 Groundwater RAA Comparison	5-41
5.2.2 Soil RAA Comparison	5-43
6.0 REFERENCES	6-1

APPENDICES

- A Analytical Data Summary Tables
- B Action Level Calculations
- C Remedial Action Alternative Cost Estimates

LIST OF TABLES

<u>Number</u>	<u>Page</u>
ES-1 Preliminary Remediation Goals	ES-
ES-2 Final Contaminants of Concern Exceeding Preliminary Remediation Goals .	ES-15
ES-3 Summary of Detailed Analysis - Groundwater RAAs	ES-20
ES-4 Summary of Detailed Analysis - Soil RAAs	ES-20
1-1 Removal Action Drum and Container Summary	1-18
2-1 Preliminary Contaminants of Concern	2-2
2-2 Potential Contaminant-Specific ARARs	2-6
2-3 Potential Location-Specific ARARs Evaluated for Operable Unit No. 2	2-10
2-4 Potential Action-Specific ARARs	2-13
2-5 Inhalation of Particulates Action Levels	2-18
2-6 Ingestion of Surface Soil Action Levels	2-20
2-7 Surface Soil - Dermal Contact Action Levels	2-22
2-8 Input Parameters used to Estimate Ingestion of Groundwater Action Levels .	2-24
2-9 Input Parameters used to Estimate Contaminant Migration from Soil to Groundwater Action Levels	2-26
2-10 Particulate Inhalation Carcinogenic Action Levels	2-28
2-11 Particulate Inhalation Noncarcinogenic Action Levels	2-29
2-12 Surface Soil Ingestion Carcinogenic Action Levels	2-30
2-13 Surface Soil Ingestion Noncarcinogenic Action Levels	2-31
2-14 Surface Soil Dermal Contact Carcinogenic Action Levels	2-32
2-15 Surface Soil Dermal Contact Noncarcinogenic Action Levels	2-33
2-16 Groundwater Ingestion Action Levels Based on Carcinogenic Risk	2-35
2-17 Groundwater Ingestion Action Levels Based on Noncarcinogenic Risk	2-36
2-18 Estimated Groundwater Concentrations and Soil Action Levels Determined from the OLM Compared to Federal and State Criteria	2-37
2-19 Comparison of Particulate Inhalation Risk-Based Action Levels to Maximum Contaminant per Grid Area	2-39
2-20 Comparison of Soil Ingestion Risk-Based Action Levels to Maximum Contaminant Concentrations per Grid Area	2-40
2-21 Comparison of Dermal Contact Risk-Based Action Levels to Maximum Contaminant Concentrations per Grid Area	2-42
2-22 Preliminary Remediation Goals	2-46
2-23 Final Contaminants of Concern Exceeding Preliminary Remediation Goals .	2-48
2-24 Remedial Action Objectives Applicable to OU No. 2	2-53
3-1 General Response Actions for Operable Unit No. 2	3-2
3-2 Potential Set of Remedial Action Technologies and Process Options Identified for Operable Unit No. 2.	3-5
3-3 Preliminary Screening of Groundwater Technologies and Process Options ..	3-8
3-4 Preliminary Screening of Soil Technologies and Process Options	3-14
3-5 Set of Potential Technologies/Process Options that Passed the Preliminary Screening	3-19
3-6 Summary of Groundwater Process Option Evaluation	3-22
3-7 Summary of Soil Process Option Evaluations	3-29
3-8 Final Set of Potential Remedial Action Technologies and Process Options ...	3-34

LIST OF TABLES

<u>Number</u>		<u>Page</u>
4-1	Potential Set of Groundwater Remedial Action Alternatives	4-2
4-2	Potential Set of Soil Remedial Action Alternatives	4-3
4-3	Applicable Technologies for the Soil AOCs	4-27
5-1	Summary of Detailed Evaluation - Groundwater RAAs	5-36
5-2	Summary of Detailed Evaluation - Soil RAAs	5-38

LIST OF FIGURES

<u>Number</u>		<u>Page</u>
1-1	Location Map Operable Unit No. 2, Sites 6, 9, and 82	1-5
1-2	Site Plan of Sites 6, 9, and 82	1-6
1-3	Site Plan of Site 9	1-7
1-4	Time Critical Removal Action Drum Locations	1-17
2-1	Approximate Location of Groundwater Contamination	2-50
2-2	Approximate Location of Soil Areas of Concern	2-52
4-1	Groundwater RAA No. 2: Limited Action	4-5
4-2	Groundwater RAA No. 3: Containment	4-8
4-3	Typical Deep Groundwater Extraction Well Construction Diagram	4-9
4-4	Groundwater Treatment Train Schematic	4-11
4-5	Groundwater RAA No. 4: Intensive Groundwater Extraction and Treatment	4-14
4-6	Groundwater RAA No. 5: Groundwater Extraction and Treatment	4-17
4-7	Soil RAA No. 2: Capping	4-20
4-8	Typical Multilayered Cap	4-22
4-9	Soil RAA No. 3: On-Site Treatment	4-25
4-10	Land Treatment Schematic	4-28
4-11	Vapor Extraction Well Schematic	4-30
4-12	In Situ Volatilization Schematic	4-31
4-13	Chemical Dechlorination Schematic	4-32
4-14	Incineration Schematic	4-34
4-15	Soil RAA No. 4: Capping and On-Site Treatment	4-36
4-16	Soil RAA No. 6: Capping and On-Site Treatment (Limited Areas of Concern)	4-40
4-17	Soil RAA No. 7: On-Site Treatment and Off-Site Disposal	4-43

EXECUTIVE SUMMARY

INTRODUCTION

Marine Corps Base (MCB) Camp Lejeune was placed on the Comprehensive Environmental Response, Compensation, and Liability Act (CERCLA) National Priorities List (NPL) on October 4, 1989 (54 Federal Register 41015, October 4, 1989). The United States Environmental Protection Agency (USEPA) Region IV, the North Carolina Department of Environment, Health and Natural Resources (NC DEHNR) and the United States Department of the Navy (DoN) then entered into a Federal Facilities Agreement (FFA) for MCB Camp Lejeune. The primary purpose of the FFA was to ensure that environmental impacts associated with past and present activities at the MCB were thoroughly investigated and appropriate CERCLA response/Resource Conservation and Recovery Act (RCRA) corrective action alternatives were developed and implemented as necessary to protect public health and the environment.

The Fiscal Year 1994 Site Management Plan for MCB Camp Lejeune, a primary document identified in the FFA, identifies several sites requiring Remedial Investigation/Feasibility Study (RI/FS) activities. This report documents the FS completed for three of these sites: Site 6 (Storage Lots 201 and 203), Site 9 (Fire Fighting Training Pit at Piney Green Road), and Site 82 (Piney Green Road VOC Area). Collectively these sites comprise Operable Unit (OU) No. 2. The purpose of this FS is to select a remedy that: is protective of human health and the environment; attains Federal and State requirements; and is cost effective.

This FS has been conducted in accordance with the guidelines and procedures delineated in the National Contingency Plan (NCP) for remedial actions (40 CFR 300.430). The USEPA's document Guidance for Conducting Remedial Investigations and Feasibility Studies Under CERCLA (USEPA, 1988a) has been used as guidance for preparing this document. This FS has been based on data collected during the RI conducted at OU No. 2 (Baker, 1993).

SITE DESCRIPTION AND HISTORY

OU No. 2 is located approximately two miles east of the New River and two miles south of State Route 24 on the main section of MCB Camp Lejeune. The unit is bordered by Holcomb Boulevard on the west, Sneads Ferry Road on the south, Piney Green Road on the east, and by

Wallace Creek on the north boundary. Camp Lejeune Railroad operates rail lines parallel to Holcomb Boulevard bordering OU No. 2. OU No. 2 covers an area of approximately 210 acres.

As previously stated, OU No. 2 consists of three sites: Site 6, Site 9, and Site 82. The background for each of these sites is described below.

Site 9

Site 9 is the "Fire Fighting Training Pit at Piney Green Road," (also referred to as the "Fire Training Area"). The site covers an area of approximately 2.6 acres. In general, Site 9 is bounded by Holcomb Boulevard on the west, Bear Head Creek approximately 500 feet to the north, Piney Green Road on the east, and Sneads Ferry Road on the south. Locally, the site is bounded by unnamed streets leading to various storage buildings in the vicinity. In addition, Site 6 forms the northern boundary of Site 9.

Site 9 consists of an asphalt-lined fire training pit, an oil/water separator, four aboveground storage tanks (ASTs), three propane tanks, and a fire tower (smoke house). The fire training pit, located in the southern area of the site, is used to conduct training exercises for extinguishing fires caused by flammable liquids. The oil/water separator is located next to the fire training pit to collect water used in the training exercises and storm water that falls into the pit. The recovered product collected in the oil/water separator is disposed off site. Two of the ASTs are 2500-gallon steel tanks that are not used. Two additional storage tanks are located in a concrete containment area. These tanks are constructed of steel and contain approximately 500 gallons of fuel. These tanks are currently in use.

Site 9 has been used as a fire fighting training area from the early 1960s to the present. Originally, fire extinguishing activities took place in an unlined pit. In 1981 the pit was lined with asphalt. The training fires in the pit were started with used oil, solvents, and contaminated fuels (unleaded). Approximately 30,000 to 40,000 gallons of JP-4 and JP-5 fuel were also burned in the fire training pit.

Site 6

Site 6 is located in between Sites 9 and 82. Site 6 is bounded on the north by Site 82, by Piney Green Road on the east, by Site 9 on the south, and by the Camp Lejeune Railroad (Holcomb Boulevard) on the west. Site 6 covers an area of approximately 177 acres that incorporates

Storage Lots 201 and 203, the wooded area between the storage lots, and the ravine. Three surface water bodies are associated with Site 6 for purposes of this FS: Wallace Creek, Bear Head Creek, and a ravine located north of Open Storage Lot 203 that drains to Wallace Creek.

Open Storage Lot 201 is a fenced lot located in the south central portion of Site 6. It is a flat area with sparse vegetation around the fence lines. The lot is approximately 25 acres in size. It is currently being used for the storage of military vehicles and equipment, lumber, hydraulic oils and lubricants, nonpolychlorinated biphenyl (PCB) transformers, and other supplies (ESE, 1992).

Open Storage Lot 203 is a currently inactive fenced lot located in the northern portion of Site 6 covering approximately 41 acres. Lot 203 is a relatively flat area with elevation differences of approximately five feet. The ground surface is comprised of both naturally existing soil and fill material. Lot 203 is bordered by Site 82 to the north, Piney Green Road to the east, woods to the south, and by Holcomb Boulevard to the west. From historical photographs, it appears that the fenced boundaries have changed since the lot was placed in operation. Former employees at Lot 203 have reported disposal of various chemicals including PCBs, cleaning solvents, electrolytes from used batteries, and waste oils. Currently, the lot is randomly littered with scrap materials such as rubber rafts, shredded tires, spent ammunition casings, fencing, metal debris, and 55-gallon drums.

The 55-gallon drums present on Lot 203 were observed in small groupings throughout the lot. The majority of the drums, if labeled, were identified as containing lubricants, petroleum products, or corrosives. Empty storage tanks were also found on Lot 203. They were labeled as containing diesel fuel, gasoline, and kerosene (Baker, 1992).

A ravine is located immediately north of Lot 203 and bisects Site 82. The elevation ranges from 25 feet above mean sea level (msl) at the north boundary of Lot 203 to 5 feet above msl where the ravine drains into Wallace Creek. The surface of the ravine area is littered with various debris including batteries, fencing, tires, empty unlabeled drums, wire cables, commercial ovens, commodes, and respirator cartridges. An empty drum labeled "DDT" (which is dichlorodiphenyltrichloroethane) was also found in the ravine area, as were small canisters labeled "DDT".

Woods and open fields surround both Storage Lots 201 and 203 and make up the remaining area of Site 6. The topography of the wooded areas is relatively flat, but localized trenching

and mounding is visible west of Piney Green Road. The wooded areas are randomly littered with debris including spent ammunition casings, and empty or rusted drums. Many of the drums observed were only shells or fragments of drums. (Baker, 1992)

Site 82

Site 82, Piney Green Road VOC Site, is located directly north and adjacent to Site 6. It is bordered to the north by Wallace Creek, to the east by Piney Green Road, to the west by Holcomb Boulevard, and to the south by Site 6. Site 82 encompasses approximately 30 acres. The site is randomly littered with debris including communication wire, spent ammunition casings, and empty or rusted drums. A few of the drums had identifiable markings indicating "lubrication oil" and "antifreeze".

INVESTIGATION AND STUDY HISTORY

Investigations at OU No. 2 date back to 1983. The studies/investigations that have been conducted with respect to at least one of the three sites within OU No. 2 include:

- Initial Assessment Study of MCB Camp Lejeune; 1983
- Confirmation Study for Sites 6 and 9; 1984 - 1986
- Site Survey for Site 6; 1989
- Site Investigation for Site 82; 1991
- Site Assessment for Sites 6 and 9; 1992
- Remedial Investigation for Sites 6, 9, and 82; 1993
- Baseline Risk Assessments for Sites 6, 9, and 82; 1993

NATURE AND EXTENT OF CONTAMINATION

Based on the results of the various environmental investigations conducted at OU No. 2 during the Remedial Investigation, the following conclusions with respect to the nature and extent of contamination at the three sites were developed as listed below. Note that various drums and containers were noted throughout Sites 6 and 82. All surficial drums/containers are being removed from OU No. 2 through a Time Critical Removal Action. This action will be conducted prior to implementing any remedial alternative.

Site 9

- Ongoing fire training exercises at Site 9 have not significantly impacted either soil or groundwater quality.
- Low levels of pesticides present at Site 9 are likely the result of former pest control practices and not associated with past site operations.
- Potential human health risks to military personnel training at Site 9 are within the incremental carcinogenic risk (ICR) range of $1.0E-4$ to $1.0E-6$.

Site 6 - Lot 201

- The northeast corner of Lot 201 at the former pesticide storage area is contaminated with elevated levels of pesticides and volatiles that may be associated with former waste storage/handling activities. The extent of soil contamination is limited in area since only two sampling locations exhibited elevated contaminant levels.
- Former waste storage/handling activities at Lot 201 have not adversely impacted groundwater quality in this portion of OU No. 2.
- The presence of low levels of pesticides throughout Lot 201 is indicative of former pest control practices and is probably not associated with the former storage of pesticides. Low levels of pesticides were detected at similar concentrations throughout the 210-acre operable unit.
- Reported storage of PCB transformers at Lot 201 has not resulted in significant impacts to soil or groundwater.
- Overall, the current health risk to base personnel working at Lot 201 is within the ICR range of $1.0E-4$ to $1.0E-6$.

Site 6 - Lot 203

- Pesticide levels detected in soil at Lot 203 are not indicative of pesticide disposal. Pesticide levels at Lot 203 are comparable to other portions of OU No. 2. The southeast corner of Lot 203 did not reveal elevated pesticide levels given that pesticides were reported to be disposed of in this area.
- The area of Lot 203 near the former railroad spur may be associated with previous disposal activities. A limited number of surface and subsurface soil samples collected near the former railroad spur have revealed elevated levels of PCB (PCB-1260) and polynuclear aromatic hydrocarbons (PAHs). Historical aerial photographs indicate significant activity (i.e., surficial anomalies) in this area of Lot 203.
- Disposal activities may have occurred in the north central portion of Lot 203 (near well 6GW15) where elevated levels of PCBs were detected in subsurface soil samples. In addition to PCBs, elevated levels of PAHs were also detected in this area.
- The reported PCB disposal area in the northeast corner of Lot 203 did not reveal elevated levels of PCBs. The reported area may have been inaccurately identified in Marine Corps memorandums.
- Military training operations at Lot 203 resulted in a substantial amount of buried debris including communication wire, shell casings, battery packs, small 5-gallon containers, and bivouac wastes. No 55-gallon drums were uncovered in any of the 29 test pit excavations. Trenches identified in historical photographs were primarily excavated as a means to dispose of military-type wastes and not for purposes of disposing hazardous wastes.
- Numerous drums on the surface of Lot 203 present a potential impact to human health and the environment. Samples collected from these drums indicate that some of the drum contents are characteristically hazardous. None of the drums were noted to be leaking. These drums are planned to be removed from the sites during a Time Critical Removal Action.
- Groundwater quality at Lot 203 has not been significantly impacted by former disposal and storage practices. Trace levels of trichloroethene (TCE) were detected in

well 6GW15, which is located in the north central portion of Lot 203 where disposal activities may have occurred. Trace levels of TCE and tetrachloroethene (PCE) were detected in well 6GW23.

- Currently, Lot 203 is inactive and access is restricted. If the storage lot resumed operations, the potential human health risk (i.e., ICR) would be within the target range of $1.0E-4$ to $1.0E-6$.

Site 6 - Wooded Areas

- PCBs were detected in the surface soil near Piney Green Road east of Lot 201. Disposal activities may have occurred in this area, which once served as a training area.
- A former disposal area was identified during the test pit investigation in the wooded area between Lot 201 and Lot 203. Numerous 5-gallon containers, bivouac wastes, and battery packs were encountered. All of the containers were rusted and damaged to the point where their contents could not be identified; however, solvent-like odors were detected by the sampling team. A sample of the sludge material near the containers revealed that the material is characteristically hazardous due to elevated levels of lead. Chloroform was also detected, but was below Toxicity Characteristics Leaching Procedure (TCLP) regulatory levels. These containers are to be removed during a Time Critical Removal Action.
- Groundwater quality in the wooded area south of Lot 203 (near the above-mentioned disposal area) has been impacted by former disposal practices. Elevated levels of VOCs (chloroform, chlorobenzene, phenol) were encountered in two wells.
- Potential human exposure to soil within the wooded portions of OU No. 2 would not result in significant health risks. ICR values are within the acceptable risk range of $1.0E-4$ and $1.0E-6$. The area is frequented by hunters and military personnel.

Site 82

- Site 82 exhibited elevated VOC contaminant levels in soil at two locations near the eastern portion of the site. This area is a potential source of VOC contamination in groundwater.
- A large quantity of surficial drums and debris were observed within the site. This area may also be a source of groundwater contamination at Site 82.
- Shallow and deep groundwater within Site 82 exhibited elevated levels of VOC contaminants. Deep groundwater quality was found to be significantly more contaminated than shallow groundwater quality.
- The horizontal extent of shallow groundwater contamination is defined. The plume apparently originates just north of Lot 203 (i.e., in the southeastern portion of Site 82) and discharges into Wallace Creek. Contaminants have migrated into the deeper portion of the aquifer as evidenced by elevated VOC levels in deep groundwater monitoring wells.
- The horizontal and vertical extent of the deep groundwater contamination has been essentially defined. The horizontal extent of off-site contamination west of Site 82 (beyond well 6GW37D), however, has not been fully evaluated. Moreover, the vertical extent has been evaluated to a depth of 230 feet. It is unknown at this time whether contamination extends below 230 feet. As mentioned previously, a clay layer is present at approximately 230 feet which may impede the vertical migration of contamination. For purposes of conducting the baseline human health and ecological risk assessment, the current deep groundwater database is adequate. For purposes of performing a feasibility study on the deep aquifer, the current database is also adequate to select feasible remedial alternatives. However, additional data points west of Holcomb Boulevard are required to support the design of an alternative which may employ containment/extraction wells.

Ravine

- None of the TCL organics detected in the ravine exceeded applicable water quality criteria values. Surface water concentrations of aluminum, cadmium, copper, iron,

lead, silver, and zinc exceeded applicable criteria in some of the samples. The exceedances of these TAL inorganics occurred in upstream and/or downstream samples or were infrequent in occurrence.

- The presence of elevated levels of PAHs in soil and low levels of PCBs in sediment in the upper portion of the ravine (i.e., near Lot 203) is most likely due to former disposal practices. This portion of the ravine is filled with debris, including empty and partially-filled 55-gallon drums. In addition, canisters with "DDT" markings were found in the middle section of the ravine (between Lot 203 and Wallace Creek). However, no elevated levels of pesticides were detected in the ravine sediments.
- Soil contamination detected in the ravine has likely migrated to Wallace Creek via surface runoff. Wallace Creek sediments revealed the same constituents detected in ravine soils and sediments.
- Because of the amount of debris and difficulty in accessing the ravine, it is unlikely that human exposure would occur. ICR estimates for the wooded areas and ravine area have indicated that potential human health risks are within the target range of 1.0E-4 and 1.0E-6.

Wallace Creek

- The presence of TCE, PCE, and other VOC contaminants in Wallace Creek is due to shallow and possibly deep groundwater discharge.
- Surface runoff from the ravine has impacted sediment quality. Elevated levels of PAHs and PCBs are present in Wallace Creek. These contaminants were also detected in the ravine.
- Pesticides detected in sediment samples have exceeded EPA Region IV sediment screening values. The source of contamination may be due to either runoff from the ravine and/or historical pest control spraying practices. The highest levels of pesticides were detected in two sampling stations that were located just downstream of where the ravine discharges into Wallace Creek. One upstream sampling location exhibited pesticide levels above the sediment screening values.

- None of the organic chemicals of concern detected in Wallace Creek exceeded applicable water quality standards.
- Inorganic levels for aluminum, cadmium, copper, iron, lead, mercury, nickel, silver, and zinc exceeded North Carolina Water Quality Standards and/or EPA Region IV acute or chronic water quality screening values. Upstream sampling locations also exhibited inorganic levels which exceeded these standards. The presence of inorganic constituents in Wallace Creek may be associated with surface runoff from the ravine.
- The fish population and diversity in Wallace Creek appears to be healthy, based on population statistics. No anomalies were observed on any of the fish collected during the aquatic survey.
- Some of the fish collected in Wallace Creek exhibited tissue concentrations of PCBs, pesticides, and TCE, which may be attributable to Site 82 and the ravine area. Ingestion of fish taken from Wallace Creek could result in human health risks (ICRs) above the target point of 1.0E-4.

Bear Head Creek

- Sediment quality in Bear Head Creek may be impacted via surface runoff from the wooded areas. Low levels of PAHs, pesticides, and PCBs were detected in sampling stations which border Site 6. VOC contaminants were also detected in sediment samples; however, the source of this contamination is unknown given that adjacent soil and groundwater did not exhibit VOC contamination. Pesticides in sediment are not likely associated with disposal practices.
- Inorganic constituents detected in sediment are not likely the result of disposal practices at Sites 6 or 9.
- The fish community at Bear Head Creek appears to be healthy, based on population statistics and observations. None of the fish collected at Bear Head Creek exhibited lesions or other anomalies that would represent adverse conditions.

- The fish community in Bear Head Creek had elevated levels of pesticides, PCBs, and zinc in tissue. The presence of these contaminants in fish tissue is likely the result of contaminated sediment. Ingestion of fish taken from Bear Head Creek could result in ICRs above 1.0E-4.

DEVELOPMENT OF REMEDIATION GOALS AND COCS

The preliminary remediation goals associated with OU No. 2 are presented on Table ES-1. This list was based on a comparison of contaminant-specific ARARs and the site-specific risk based action levels (see Section 2.0 of the FS). If a COC had an ARAR, the most limiting (or conservative) ARAR was selected as the remediation goal for that contaminant. If a COC did not have an ARAR, the most conservative risk-based action level was selected for the remediation goal. The basis for each of the remediation goals is also presented in Table ES-1.

In order to determine the critical set of COCs for OU No. 2, the contaminant concentrations detected in both media were compared to the preliminary remediation goals presented on Table ES-1. The contaminants which exceeded at least one of the remediation goals have been retained as COCs. The contaminants that did not exceed any of the preliminary remediation goals will no longer be considered as COCs with respect to this FS. Based on this comparison, the following COCs exceeded a remediation goal and will be retained as COCs for OU No. 2:

- | | |
|----------------------------|---------------------|
| ● <u>Groundwater</u> | ● <u>Soil</u> |
| - 1,2-Dichloroethane | - PCBs |
| - Trans-1,2-Dichloroethene | - Benzene |
| - Ethylbenzene | - Trichloroethene |
| - Tetrachloroethene | - Tetrachloroethene |
| - Trichloroethene | - 4,4'-DDT |
| - Vinyl Chloride | - Arsenic |
| - Arsenic | - Cadmium |
| - Barium | - Manganese |
| - Beryllium | |
| - Chromium | |
| - Lead | |
| - Manganese | |
| - Mercury | |
| - Vanadium | |

The final set of COCs and their associated remediation goals are presented on Table ES-2.

TABLE ES-1

PRELIMINARY REMEDIATION GOALS
 FEASIBILITY STUDY CTO-0133
 MCB CAMP LEJEUNE, NORTH CAROLINA

Medium	Contaminant of Concern	Remediation Goal	Unit	Basis of Goal	Corresponding Risk	
					Carcinogenic	Noncarcinogenic
Groundwater	Bromodichloromethane	100	µg/L	MCL	ICR = 1.0E-4	
	Chlorobenzene	300	µg/L	MCL		
	1,2-Dichloroethane	0.38	µg/L	NC WQS		
	1,1-Dichloroethene	7	µg/L	MCL		
	Trans-1,2-Dichloroethene	70	µg/L	NC WQS		
	Ethylbenzene	29	µg/L	NC WQS		
	1,1,2,2-Tetrachloroethane	43	µg/L	Risk-Ingestion		
	Tetrachloroethene	0.7	µg/L	NC WQS		
	1,1,1-Trichloroethane	200	µg/L	NC WQS		
	1,1,2-Trichloroethane	5	µg/L	MCL		
	Trichloroethene	2.8	µg/L	NC WQS		
	Vinyl Chloride	0.015	µg/L	NC WQS		
	Xylenes	400	µg/L	NC WQS		
	Phenol	6,000	µg/L	Health Advisory		
	Antimony	50	µg/L	MCL		
	Arsenic	50	µg/L	NC WQS		
	Barium	1,000	µg/L	NC WQS		
	Beryllium	4	µg/L	MCL		
	Chromium	50	µg/L	NC WQS		
	Copper	1,000	µg/L	NC WQS		
	Lead	15	µg/L	MCL		
	Manganese	50	µg/L	NC WQS		
	Mercury	1.1	µg/L	NC WQS		
	Nickel	100	µg/L	MCL		
	Vanadium	80	µg/L	Health Advisory		
	Zinc	5,000	µg/L	NC WQS		

ES-12

TABLE ES-1 (Continued)

PRELIMINARY REMEDIATION GOALS
FEASIBILITY STUDY CTO-0133
MCB CAMP LEJEUNE, NORTH CAROLINA

Medium	Contaminant of Concern	Remediation Goal	Unit	Basis of Goal	Corresponding Risk	
					Carcinogenic	Noncarcinogenic
Soil	PCBs	10,000	µg/kg	TSCA nonrestricted access area		
	Benzene	5.4	µg/kg	Risk-Protection of Groundwater		
	Trichloroethene	32.2	µg/kg	Risk-Protection of Groundwater		
	Tetrachloroethene	10.5	µg/kg	Risk-Protection of Groundwater		
	1,2-Dichloroethene	780,000	µg/kg	Risk-Ingestion		HI = 1.0
	1,1,2,2-Tetrachloroethane	160,000	µg/kg	Risk-Dermal Contact	ICR = 1.0E-4	
	1,1,1-Trichloroethane	7,000,000	µg/kg	Risk-Ingestion		HI = 1.0
	1,4-Dichlorobenzene	1,300,000	µg/kg	Risk-Dermal Contact	ICR = 1.0E-4	
	4,4'-DDD	270,000	µg/kg	Risk-Dermal Contact	ICR = 1.0E-4	
	4,4'-DDE	60,000	µg/kg	Risk-Dermal Contact	ICR = 1.0E-4	
	4,4'-DDT	60,000	µg/kg	Risk-Dermal Contact	ICR = 1.0E-4	
	Dieldrin	40,000,000	µg/kg	Risk-Inhalation	ICR = 1.0E-4	
	Arsenic	23,000	µg/kg	Risk-Ingestion		HI = 1.0
	Barium	5,500,000	µg/kg	Risk-Ingestion		HI = 1.0
	Beryllium	21,000	µg/kg	Risk-Ingestion	ICR = 1.0E-4	
	Cadmium	39,000	µg/kg	Risk-Ingestion		HI = 1.0
	Chromium	390,000	µg/kg	Risk-Ingestion		HI = 1.0
	Manganese	390,000	µg/kg	Risk-Ingestion		HI = 1.0
Zinc	23,000,000	µg/kg	Risk-Ingestion		HI = 1.0	

TABLE ES-2

FINAL
 REMEDIATION GOALS FOR OU NO. 2
 FEASIBILITY STUDY CTO-0133
 MCB CAMP LEJEUNE, NORTH CAROLINA

Media	Contaminant of Concern	Preliminary Remediation Goal	Unit
Groundwater	1,2-Dichloroethane	0.38	µg/L
	Trans-1,2-Dichloroethene	70	µg/L
	Ethylbenzene	29	µg/L
	Tetrachloroethene	0.7	µg/L
	Trichloroethene	2.8	µg/L
	Vinyl Chloride	0.015	µg/L
	Arsenic	50	µg/L
	Barium	1,000	µg/L
	Beryllium	4	µg/L
	Chromium	50	µg/L
	Lead	15	µg/L
	Manganese	50	µg/L
	Mercury	1.1	µg/L
	Vanadium	80	µg/L
Soil	PCBs	10,000	µg/kg
	4,4'-DDT	60,000	µg/kg
	Benzene	5.4	µg/kg
	Trichloroethene	32.2	µg/kg
	Tetrachloroethene	10.5	µg/kg
	Arsenic	23,000	µg/kg
	Cadmium	39,000	µg/kg
	Manganese	390,000	µg/kg

REMEDIAL ACTION ALTERNATIVE DEVELOPMENT AND EVALUATION

Based on the information collected during the RI, and the evaluation of potential human health and ecological risks, remedial action alternatives (RAAs) were developed to address contaminated media at various areas of concern (AOCs) within OU No. 2.

The AOCs included:

- VOC contaminated groundwater plumes originating from Site 82.
- Four small areas of groundwater contamination south and west of Storage Lot 203.
- Source of groundwater VOC contamination at Site 82 (Soil AOC1).
- Upper portion of the ravine at Site 6 with detected levels of PAHs, PCBs and metals in soil and sediment (Soil AOC2). This may be a source of contamination to Wallace Creek.
- North central portion of Lot 203 (near well 6GW15) with elevated levels of PCBs in soil (Soil AOC3).
- Northwestern portion of Lot 203 (near well 6GW11) with elevated levels of PCBs in soil (Soil AOC4).
- Northeast corner of Lot 201 with elevated levels of pesticides in soil (Soil AOC5).
- Wooded area east of Lot 201 and adjacent to Piney Green Road with elevated levels of PCBs in soil (Soil AOC6).

Note that no AOCs were identified within Site 9 or Wallace Creek. In addition, areas where drums and containers have been identified are not being considered as AOCs for this FS. All surficial drums and known buried drums/containers are being removed from OU No. 2 through a Time Critical Removal Action. Therefore, these activities will be conducted prior to implementing any RAA developed in this FS.

With respect to Wallace Creek, remediation of contaminated sediments or surface water would likely result in greater risks to the environment during the actual remediation stage (e.g., sediment dredging would suspend sediments and contaminants would migrate further downstream). Therefore, direct remediation of surface water and sediment will not be conducted. However, Wallace Creek may be indirectly remediated by remediating the source of surface water and sediment contamination (i.e., groundwater and soil, respectively).

Five groundwater RAAs were developed and evaluated. These alternatives include:

- RAA No. 1 - No Action
- RAA No. 2 - Limited Action
- RAA No. 3 - Containment
- RAA No. 4 - Intensive Groundwater Extraction and Treatment
- RAA No. 5 - Groundwater Extraction and Treatment

The No Action RAA (No. 1) is required under CERCLA to compare against other alternatives. There are no capital or operation and maintenance costs associated with this alternative.

The Limited Action RAA (No. 2) primarily involves the institution of ordinances banning the use of nearby potable supply wells which are contaminated and/or the construction of new wells in the area. Long-term groundwater monitoring (including operational supply wells) is also included with this alternative. No capital costs are required to implement this alternative. Long-term O&M costs are estimated at \$39,000 annually. The net present worth (NPW) of this alternative is approximately \$600,000.

RAA No. 3 (Containment) includes the installation of extraction wells to contain the migration of the plume. Six extraction wells will be installed at a depth of approximately 110 feet to contain the migration of the deep groundwater plume. Six shallow wells will be installed at a depth of 35 feet to contain the migration of contaminants in the surficial aquifer. The placement of the wells will be for purpose of containing the groundwater plume originating from Site 82. Each deep extraction well will pump the groundwater at a rate of approximately 150 gallons per minute. The shallow extraction wells will pump at a rate of 5 gallons per minute. Treatment will consist of metals removal, air stripping, and carbon adsorption. The use of biological treatment prior to air stripping will be considered during the design of the alternative. Treated effluent will be discharged to Wallace Creek. This RAA will include semi-annual sampling and analysis (TCL volatile organics) of groundwater from

nine deep monitoring wells, twelve shallow monitoring wells, and three local supply wells. Aquifer-use restrictions will be placed on the two currently closed local supply wells. In addition, deed restrictions will be placed restricting the installation of any new wells within the vicinity of OU No. 2. The capital and O&M costs associated with this RAA are \$2.6 million and \$285,000, respectively. The NPW is \$7.0 million.

RAA No. 4 (Intensive Groundwater Extraction and Treatment) includes the treatment of the VOC plume at the area with the highest level of contamination. This area is primarily located at Site 82, east of the ravine and west of Piney Green Road. This RAA will include a series of deep and shallow extraction wells located in the most contaminated areas of the sites. The extracted groundwater will be treated on site and then discharged to Wallace Creek. In addition, this RAA includes the same institutional controls as Groundwater RAA Nos. 2 and 3. The objective of this RAA is to focus on the "most contaminated" areas of the groundwater contamination. This area also acts as a source of surface water contamination at Wallace Creek, and the source of off-site groundwater contamination. The cone of influence created by the extraction wells are expected to reach the downgradient boundary of the plume. Under this alternative, groundwater extraction and treatment will be employed until the remediation goals are met.

RAA No. 4 will include semi-annual sampling and analysis of groundwater from nine deep monitoring wells, twelve shallow monitoring wells, and three local supply wells (TCL volatile organics). Aquifer-use restrictions will be placed on the two nearby supply wells that are currently closed. In addition, deed restrictions will be placed restricting the installation of any new wells within the vicinity of OU No. 2. The capital and O&M costs associated with this RAA are \$1.4 million and \$230,000, respectively. The NPW is \$4.9 million.

RAA No. 5 (Extraction and Groundwater Treatment) includes the extraction and treatment of the contaminant plumes of groundwater. In addition, this RAA includes the same institutional controls as Groundwater RAA Nos. 2, 3, and 4. The objective of this RAA is to reduce the contaminants in the groundwater to drinking water standards for a Class I aquifer, and to mitigate the further migration of the existing groundwater plumes. The primary difference between this alternative and RAA No. 4 is the shorter timeframe expected to meet the remediation goals.

RAA No. 5 will include semiannually sampling and analysis (TCL volatile organics) of groundwater from nine deep monitoring wells, twelve shallow monitoring wells, and three

local supply wells. Aquifer-use restrictions will be placed on the two currently closed local supply wells. In addition, deed restrictions will be placed restricting the installation of any new wells within the vicinity of OU No. 2. The capital and O&M costs are estimated at \$3.5 and \$350,000, respectively. The NPW is \$8.9 million.

The remedial alternatives for addressing groundwater were evaluated against nine evaluation criteria. These criteria included overall protection of public health and the environment; compliance with ARARs; long-term effectiveness of permanence; reduction of toxicity, mobility, or volume; short-term effectiveness; implementability; cost; EPA and DEHNR acceptance; and community acceptance.

A comparison of these alternatives with respect to these evaluation criteria is provided on Table ES-3.

Seven RAAs have been developed to address the soil AOCs. These alternatives include:

- RAA No. 1 - No Action
- RAA No. 2 - Capping
- RAA No. 3 - On-Site Treatment
- RAA No. 4 - Capping and On-Site Treatment (All Areas of Concern)
- RAA No. 5 - Off-Site Treatment/Disposal
- RAA No. 6 - Capping and On-Site Treatment (Limited Areas of Concern)
- RAA No. 7 - On-Site Treatment and Off-Site Disposal

Under Soil RAA No. 1, no remedial actions will be performed to reduce the toxicity, mobility, or volume of contaminants in the soil at OU No. 2. The No Action RAA is required by the NCP to provide a baseline for comparison with other soil alternatives that provide a greater level of response. Soil RAA No. 1 involves leaving the contaminated soils from Site 82 and Site 6 in place. Under this RAA, the VOC, and pesticide concentrations in the soil may slowly decrease as a result of natural biodegradation. The natural degradation of the PCB-contaminated soils is unknown.

The no action alternative is required by the NCP to provide a baseline for comparison with other RAAs. Since contaminants will remain at the site under this alternative, the USEPA is required by the NCP [40 CFR 300.515(e)(ii)] to review the effects of this alternative no less

TABLE ES-3

**SUMMARY OF DETAILED ANALYSIS - GROUNDWATER RAAs
FEASIBILITY STUDY CTO-0133
MCB CAMP LEJEUNE, NORTH CAROLINA**

Evaluation Criteria	RAA No. 1 No Action	RAA No. 2 Limited Action	RAA No. 3 Containment	RAA No. 4 Intensive Groundwater Extraction and Treatment	RAA No. 5 Groundwater Extraction and Treatment
OVERALL PROTECTIVENESS					
<ul style="list-style-type: none"> Human Health Protection 	No reduction in risk.	Institutional controls provide protection against risk from groundwater ingestion.	Migration of plume mitigated. Pump and treat provide protection against risk from groundwater ingestion.	Groundwater plumes treated. Pump and treat provide protection against risk from groundwater ingestion.	Groundwater plumes treated. Pump and treat provide protection against risk from groundwater ingestion.
<ul style="list-style-type: none"> Environmental Protection 	Allows continued contamination of the groundwater.	Allows continued contamination of the groundwater.	Migration of contaminated groundwater is reduced by pump and treat.	Migration of contaminated groundwater is reduced by pump and treat.	Migration of contaminated groundwater is reduced by pump and treat.
COMPLIANCE WITH ARARS					
<ul style="list-style-type: none"> Chemical-Specific ARARs 	Will exceed Federal and/or NC groundwater quality ARARs.	Will exceed Federal and/or NC groundwater quality ARARs.	May not meet Federal and NC groundwater quality ARARs.	Should meet Federal and NC groundwater quality ARARs in time.	Should meet Federal and NC groundwater quality ARARs in time.
<ul style="list-style-type: none"> Location-Specific ARARs 	Not applicable.	Not applicable.	Will meet location-specific ARARs.	Will meet location-specific ARARs.	Will meet location-specific ARARs.
<ul style="list-style-type: none"> Action-Specific ARARs 	Not applicable.	Not applicable.	Will meet action-specific ARARs.	Will meet action-specific ARARs.	Will meet action-specific ARARs.
LONG-TERM EFFECTIVENESS AND PERMANENCE					
<ul style="list-style-type: none"> Magnitude of Residual Risk 	As area of contamination increases, potential risks may increase.	Risk reduced to human health since the use of the groundwater aquifer is restricted.	Risk reduced by extracting contaminated groundwater.	Risk reduced by extracting contaminated groundwater.	Risk reduced by extracting contaminated groundwater.
<ul style="list-style-type: none"> Adequacy and Reliability of Controls 	Not applicable - no controls.	Reliability of institutional controls is uncertain.	Groundwater pump and treat is reliable.	Groundwater pump and treat is reliable.	Groundwater pump and treat is reliable.
<ul style="list-style-type: none"> Need for 5-year Review 	Review would be required to ensure adequate protection of human health and the environment is maintained.	Review would be required to ensure adequate protection of human health and the environment is maintained.	Review not needed once remediation goals are met.	Review not needed once remediation goals are met.	Review not needed once remediation goals are met.

TABLE ES-3 (Continued)

SUMMARY OF DETAILED ANALYSIS - GROUNDWATER RAAs
 FEASIBILITY STUDY CTO-0133
 MCB CAMP LEJEUNE, NORTH CAROLINA

Evaluation Criteria	RAA No. 1 No Action	RAA No. 2 Limited Action	RAA No. 3 Containment	RAA No. 4 Intensive Groundwater Extraction and Treatment	RAA No. 5 Groundwater Extraction and Treatment
REDUCTION OF TOXICITY, MOBILITY, OR VOLUME THROUGH TREATMENT					
• Treatment Process Used	None.	None.	Treatment train for metals removal, air stripping, and activated carbon.	Treatment train for metals removal, air stripping, and activated carbon.	Treatment train for metals removal, air stripping, and activated carbon.
• Amount Destroyed or Treated	None.	None.	Majority of contaminants in groundwater out edges of plumes.	Majority of contaminants in groundwater.	Majority of contaminant in groundwater plumes.
• Reduction of Toxicity, Mobility or Volume	None.	None.	Reduced volume and toxicity of contaminated groundwater.	Reduced volume and toxicity of contaminated groundwater.	Reduced volume and toxicity of contaminated groundwater.
• Residuals Remaining After Treatment	Not applicable - no treatment.	Not applicable - no treatment.	Minimal residuals after goals are met.	Minimal residuals after goals are met.	Minimal residuals after goals are met.
• Statutory Preference for Treatment	Not satisfied.	Not satisfied.	Satisfied.	Satisfied.	Satisfied.
SHORT-TERM EFFECTIVENESS					
• Community Protection	Risks to community not increased by remedy implementation.	Risks to community not increased by remedy implementation.	Potential risks during extraction and treatment.	Potential risks during extraction and treatment.	Potential risks during extraction and treatment.
• Worker Protection	No significant risk to workers.	No significant risk to workers.	Protection required during treatment.	Protection required during treatment.	Protection required during treatment.
• Environmental Impacts	Continued impacts from existing conditions.	Still would be continued migration of contamination.	Aquifer drawdown during extraction. No significant impact to Wallace Creek is anticipated.	Aquifer drawdown during extraction. No significant impact to Wallace Creek is anticipated.	Aquifer drawdown during extraction. No significant impact to Wallace Creek is anticipated.
• Time Until Action is Complete	Not applicable.	Risks from potential groundwater ingestion reduced within 3 to 6 months due to institutional controls.	Estimated 30 years.	Estimated 30 years.	Estimated 30 years.
IMPLEMENTABILITY					
• Ability to Construct and Operate	No construction or operation activities.	No construction or operation activities.	Groundwater extraction and treatment systems requires installation.	Groundwater extraction and treatment systems requires installation.	Groundwater extraction and treatment systems requires installation.
• Ability to Monitor Effectiveness	No monitoring. Failure to detect contamination will result in potential ingestion of contaminated groundwater.	Proposed monitoring will give notice of failure before significant exposure occurs.	Adequate system monitoring.	Adequate system monitoring.	Adequate system monitoring.
• Availability of Services and Capacities; Equipment	None required.	None required.	Needs groundwater treatment equipment.	Needs groundwater treatment equipment.	Needs groundwater treatment equipment.
COSTS NPW	\$0	\$600,000	\$7.0 million	\$4.9 million	\$8.9 million

often than every five years. There are no capital or operation and maintenance costs associated with this alternative.

Soil RAA No. 2 includes the excavation and consolidation of the soils from all of the Soil AOCs and placement under a multilayered cap located within Open Storage Lot 203. The technologies/process options included with this RAA include monitoring, deed restrictions, fencing, capping, grading, revegetation, and soil excavation. Figure 4-8 (see Section 4.0) depicts the approximate areas of the site from which soil will be excavated, and also shows the proposed location of the on-site cap.

The principal objectives of this RAA are to consolidate the contaminated soils into one area, to prevent the potential for direct physical contact with the contaminated soils, and to prevent the potential for the migration of contaminants by surface water infiltration. This RAA will reduce the mobility of the COCs in the soil, but will not reduce the toxicity or the volume of the contaminants. The estimated capital and O&M costs of this alternative are \$2.8 million and \$39,000, respectively. The present worth is estimated at \$3.4 million.

Soil RAA No. 3 includes the excavation and treatment of the soils from all of the Soil AOCs via on-site treatment. The technologies/process options included with this RAA include soil excavation, grading, revegetation, fencing, and on-site treatment. Figure 4-9 (see Section 4.0) depicts the approximate areas of the site from which soil will be excavated, and also shows the proposed location of the on-site treatment area. Following excavation activities, the soils will be transported to the on-site treatment area. Depending on the type of contaminants, different treatment techniques may be required at the site. For the purpose of this FS, four treatment technologies/process options have been retained as applicable for the COCs in the soils at the operable unit. They include land treatment, in situ volatilization, chemical dechlorination, and incineration.

Land treatment would be applicable for soils contaminated with biodegradable organics such as VOCs and nonchlorinated pesticides. In situ volatilization (also commonly referred to as vapor extraction) would be applicable for the VOC-contaminated soils and, to a lesser degree, SVOC-contaminated soils. Chemical dechlorination would be applicable for the PCB-contaminated soils. Whereas, a mobile incinerator would be applicable to all of the soil COCs. Table 4-3 (see Section 4.0) presents a listing of which of these technologies are applicable to the Soil AOCs. The decision as to what technology or technologies will be used under this RAA will be based on economics and implementability (refer to the detailed evaluation

presented in Section 5.0). The estimated capital and O&M costs of this alternative based on four possible technology combinations range from \$1.5 million to \$6.6 million, and \$0 to \$330,000, respectively. The present worth for these options range from \$1.7 million to \$6.6 million.

Soil RAA No. 4 is a combination of Soil RAA Nos. 2 and 3. This RAA includes the excavation and consolidation of the PCB-contaminated soils and placement under a soil cover placed within Open Storage Lot 203 (i.e., partial capping); and the excavation and treatment of the soil from the remaining Soil AOCs (i.e., partial on-site treatment). As shown in Table 4-2 (see Section 4.0), the technologies/process options included with this RAA include monitoring, deed restrictions, fencing, capping, grading, revegetation, soil excavation, and on-site treatment. Figure 4-15 (see Section 4.0) depicts the approximate areas of soil that will be excavated, and also shows the proposed locations of the on-site cap and treatment areas.

The principal objectives of this RAA are to consolidate the PCB-contaminated soils into one area and to treat the other contaminated soils on site. The main components of this alternative are described below. The rationale behind this option is based primarily on the economics of treating PCB-contaminated soils, which in general, are significantly more costly than treatment options for soils contaminated with other constituents. The estimated capital and O&M costs of this alternative are \$926,000 and \$81,000, respectively. The present worth is estimated at \$1.6 million.

Soil RAA No. 5 includes the excavation and off-site treatment and/or disposal of the contaminated soils from all of the Soil AOCs. The approximate area of soils to be excavated and treated is the same as for Soil RAA No. 3. Refer to Figure 4-10 in Section 4.0 for the areas to be excavated. The technologies/process options included under this RAA include soil excavation, grading, revegetation, and off-site treatment/disposal at a permitted facility. The estimated capital cost of this alternative is \$5.5 million (nonhazardous) and \$20.4 million (hazardous). There are no annual O&M costs associated with this alternative.

The Capping and On-Site Treatment (Limited Areas of Concern) RAA (No. 6) is essentially the same as RAA No. 4 except that some of the AOCs will not be remediated. Specifically, AOCs Nos. 2, 3, and 6 will not be remediated under this alternative since the only action level exceeded would be for future use of the area as residential. Given that the Camp Lejeune Master Plan (a planning document for future base operations) does not indicate that the area will be used for residential housing, and because this area of the base will be used for open

storage, only those AOCs (Nos. 1, 4, and 5) which exhibit levels of contaminants exceeding action levels established for the protection of base personnel working at the site, are addressed under this alternative. Under this alternative, AOC No. 1 soils will be remediated via in situ volatilization. Area of Concern No. 4 soils (PCB contamination) and AOC No. 5 soils (pesticide contamination) will be excavated and placed within Lot 203 under a soil cover. The estimated capital and O&M costs of this alternative are \$710,000 and \$81,000, respectively. The present worth is estimated at \$1.4 million.

RAA No. 7 (On-Site Treatment and Off-Site Disposal) includes the on-site treatment of the VOC-contaminated soils (AOC1) via in situ volatilization and the off-site disposal of the soils from the other AOCs. The technologies/process options included under this RAA include soil excavation, grading, revegetation, in situ treatment, monitoring, fencing, and off-site disposal. The estimated capital cost for this RAA is \$1.3 million. Annual O&M costs of \$50,000 have been estimated for 5 years. Therefore, the present worth is approximately \$1.5 million.

The remedial alternatives for addressing soil were evaluated against the nine evaluation criteria previously identified. A comparison of these soil remediation alternatives with respect to these nine criteria is provided on Table ES-4.

TABLE ES-4

SUMMARY OF DETAILED ANALYSIS - SOIL RAAs
FEASIBILITY STUDY CTO-0133
MCB CAMP LEJEUNE, NORTH CAROLINA

Evaluation Criteria	RAA No. 1 No Action	RAA No. 2 Capping	RAA No. 3 On-Site Treatment	RAA No. 4 Capping and On-Site Treatment (All Areas of Concern)	RAA No. 5 Off-Site Treatment/Disposal	RAA No. 6 Capping and On-Site Treatment (Limited Areas of Concern)	RAA No. 7 On-Site Treatment and Off-Site Disposal
OVERALL PROTECTIVENESS							
• Human Health Protection	No reduction in risk.	Would reduce potential for direct contact with contaminated soil.	Excavation removes source of contamination.	Reduces potential for direct contact with PCB-contaminated soil and removes other contaminated soils.	Excavation removes source of contamination.	Reduces potential for direct contact with PCB-contaminated soil and removes other contaminated soils - based on existing land use scenario.	Excavation and/or treatment removes source of contamination.
• Environmental Protection	Allows contaminated soils to remain on site.	Allows contaminated soils to remain on site.	No additional environmental impacts.	No additional environmental impacts.	Contaminated soils exceeding remediation goal removed and treated.	No additional environmental impacts.	No additional environmental impacts.
COMPLIANCE WITH ARARs							
• Chemical-Specific ARARs	Will exceed ARARs.	Will exceed ARARs.	Will meet contaminant-specific ARARs.	PCB ARAR not met; other contaminant-specific ARARs met.	Will meet ARARs.	PCB ARAR not met; other contaminant-specific ARARs met (with respect to existing land use scenario).	Will meet ARARs.
• Location-Specific ARARs	Not applicable.	Will meet location-specific ARARs.	Will meet location-specific ARARs.	Will meet location-specific ARARs.	Will meet location-specific ARARs.	Will meet location-specific ARARs.	Will meet location-specific ARARs.
• Action-Specific ARARs	Not applicable.	Will meet action-specific ARARs.	Will meet action-specific ARARs.	Will meet action-specific ARARs.	Will meet action-specific ARARs.	Will meet action-specific ARARs.	Will meet action-specific ARARs.
LONG-TERM EFFECTIVENESS AND PERMANENCE							
• Magnitude of Residual Risk	Source has not been removed. Potential risks not reduced.	Contaminated soils are not removed from the site, but potential risk due to exposure to COCs are reduced as long as the cap is maintained.	Potential risk due to exposure to soil COCs removed.	Potential risks reduced as long as the cover is maintained.	Potential risk due to exposure to soil COCs removed.	Potential risks with respect to existing land use scenario reduced as long as the cap is maintained.	Potential risk due to exposure to soil COCs removed.
• Adequacy and Reliability of Controls	Not applicable - no controls.	Multilayered cap controls contaminated soil - can be a reliable option if maintained properly.	All treatment options are reliable.	Soil cover can be reliable and adequate. Treatment option reliable and adequate.	Off-site treatment is very reliable because contaminated soils are removed.	Soil cover can be reliable and adequate. Treatment option reliable and adequate.	Treatment option and off-site disposal are reliable.
• Need for 5-year Review	Review would be required to ensure adequate protection of human health and the environment is maintained.	Review would be required to ensure adequate protection of human health and the environment is maintained.	Review may not be needed since contaminated soil treated (unless treatment process lasts longer than 5 years).	Review would be required to ensure adequate protection of human health and the environment is maintained.	Review not needed since contaminated soil removed.	Review would be required to ensure adequate protection of human health and the environment is maintained.	Review may not be needed since contaminated soil treated (unless treatment process lasts longer than 5 years).

TABLE ES-4 (Continued)

SUMMARY OF DETAILED ANALYSIS - SOIL RAA:
FEASIBILITY STUDY CTO-0133
MCB CAMP LEJEUNE, NORTH CAROLINA

Evaluation Criteria	RAA No. 1 No Action	RAA No. 2 Capping	RAA No. 3 On-Site Treatment	RAA No. 4 Capping and On-Site Treatment (All Areas of Concern)	RAA No. 5 Off-Site Treatment/Disposal	RAA No. 6 Capping and On-Site Treatment (Limited Areas of Concern)	RAA No. 7 On-Site Treatment and Off-Site Disposal
REDUCTION OF TOXICITY, MOBILITY, OR VOLUME THROUGH TREATMENT							
• Treatment Process Used	None.	None.	Combination of land treatment, in situ volatilization, chemical dechlorination, and/or incineration.	In situ volatilization, land treatment, or incineration.	Off-site treatment.	In situ volatilization, land treatment, or incineration.	In situ volatilization, off-site disposal.
• Amount Destroyed or Treated	None.	None.	Majority of soil COCs.	Majority of soil COCs with the exception of PCBs.	Majority of soil COCs.	Majority of soil COCs with the exception of PCBs.	Majority of soil COCs.
• Reduction of Toxicity, Mobility or Volume	None.	None (not through treatment).	Reduction in toxicity, mobility and volume of contaminated soil.	Reduction in toxicity, mobility and volume of non-PCB contaminated soils.	Reduction in toxicity, mobility and volume of contaminated soil.	Reduction in toxicity, mobility and volume of non-PCB contaminated soils.	Reduction in toxicity, mobility and volume of contaminated soil.
• Residuals Remaining After Treatment	Not applicable - no treatment.	Residuals are capped.	No residuals.	Only PCB-contaminated soils remain at sites.	No residuals.	PCB-contaminated soils and some other soil COCs.	No residuals.
• Statutory Preference for Treatment	Not satisfied.	Not satisfied.	Satisfied.	Satisfied for non-PCB contaminated soils, not for PCB-contaminated soils.	Satisfied.	Satisfied for non-PCB contaminated soils, not for PCB-contaminated soils (with respect to existing land use scenario).	Satisfied.
SHORT-TERM EFFECTIVENESS							
• Community Protection	Risks to community not increased by remedy implementation.	Temporary potential risks during soil excavation and cap installation activities.	Limited potential risks during soil excavation and treatment activities.	Temporary potential risks during soil excavation and cap installation activities and treatment activities.	Limited potential risks during soil excavation activities.	Temporary potential risks during soil excavation and cap installation activities and treatment activities.	Limited potential risks during soil excavation and treatment activities.
• Worker Protection	No significant risks to workers.	Temporary potential risks during soil excavation and cap installation activities.	Potential risks during soil excavation and treatment activities.	Temporary potential risks during soil excavation and cap installation activities and treatment activities.	Potential risks during excavation and transportation activities.	Temporary potential risks during soil excavation and cap installation activities and treatment activities.	Potential risks during soil excavation and treatment activities.
• Environmental Impacts	Continued impacts from existing conditions.	No additional environmental impacts.	Air quality and odors - but treatment system will be designed to meet standards.	Air quality and odors - but treatment system will be designed to meet standards and treatment activities.	No additional environmental impacts.	Air quality and odors - but treatment system will be designed to meet standards.	Air quality and odors - but treatment system will be designed to meet standards.
• Time Until Action is Complete	Not applicable.	Six to twelve months.	Up to five years.	Up to five years.	Six to twelve months.	Up to five years.	Up to five years.

TABLE ES-4 (Continued)

SUMMARY OF DETAILED ANALYSIS - SOIL RAAs
 FEASIBILITY STUDY CTO-0133
 MCB CAMP LEJEUNE, NORTH CAROLINA

Evaluation Criteria	RAA No. 1 No Action	RAA No. 2 Capping	RAA No. 3 On-Site Treatment	RAA No. 4 Capping and On-Site Treatment (All Areas of Concern)	RAA No. 5 Off-Site Treatment/Disposal	RAA No. 6 Capping and On-Site Treatment (Limited Areas of Concern)	RAA No. 7 On-Site Treatment and Off-Site Disposal
IMPLEMENTABILITY							
<ul style="list-style-type: none"> Ability to Construct and Operate 	No construction or operation activities.	Simple to construct and maintain. Requires materials handling procedures.	Requires soil excavation activities. Requires assembly of treatment systems.	Simple to construct and maintain. Requires materials handling procedures. Requires soil excavation activities. Requires assembly of treatment systems.	Requires soil excavation activities. No other on-site operations.	Simple to construct and maintain. Requires materials handling procedures. Requires soil excavation activities. Requires assembly of treatment systems.	Requires soil excavation activities. Requires assembly of treatment systems.
<ul style="list-style-type: none"> Ability to Monitor Effectiveness 	No monitoring included.	Cap maintenance and groundwater monitoring will adequately monitor effectiveness.	Adequate system monitoring.	Adequate system monitoring.	No monitoring other than confirmation soil sampling.	Adequate system monitoring.	Adequate system monitoring.
<ul style="list-style-type: none"> Availability of Services and Capacities; Equipment 	None required.	No special services or equipment required. Cap materials should be readily available.	May need on-site mobile incinerator.	Equipment and material should be readily available.	Needs off-site treatment services.	Equipment and material should be readily available.	Equipment and material should be readily available. Needs off-site disposal services.
COSTS NPW	\$0	\$3.4 million	\$1.7 million to \$6.6 million	\$1.6 million	\$5.5 million to \$20 million	\$1.4 million	\$1.5 million

1.0 INTRODUCTION

Marine Corps Base (MCB) Camp Lejeune was placed on the Comprehensive Environmental Response, Compensation, and Liability Act (CERCLA) National Priorities List (NPL) on October 4, 1989 (54 Federal Register 41015, October 4, 1989). The United States Environmental Protection Agency (USEPA) Region IV, the North Carolina Department of Environment, Health and Natural Resources (NC DEHNR) and the United States Department of the Navy (DoN) then entered into a Federal Facilities Agreement (FFA) for MCB Camp Lejeune. The primary purpose of the FFA was to ensure that environmental impacts associated with past and present activities at the MCB were thoroughly investigated and appropriate CERCLA response/Resource Conservation and Recovery Act (RCRA) corrective action alternatives were developed and implemented as necessary to protect public health and the environment.

The Fiscal Year 1994 Site Management Plan for MCB Camp Lejeune, a primary document identified in the FFA, identifies 27 sites requiring Remedial Investigation/Feasibility Study (RI/FS) activities. This report documents the FS completed for three of these sites: Site 6, Site 9, and Site 82. Collectively these sites comprise Operable Unit (OU) No. 2 at MCB Camp Lejeune. The purpose of this FS is to select a remedy that: is protective of human health and the environment; attains Federal and State requirements; and is cost effective.

This FS has been prepared by Baker Environmental, Inc. (Baker) under the DoN Atlantic Division Naval Facilities Engineering Command (LANTDIV) CLEAN Program for Contract Task Order 0133 (Remedial Investigation/Feasibility Study for Sites 6, 9, 48, and 69). This FS has been conducted in accordance with the guidelines and procedures delineated in the National Contingency Plan (NCP) for remedial actions [40 Code of Federal Regulations (CFR) 300.430]. These NCP regulations were promulgated under CERCLA, commonly referred to as Superfund, and amended by the Superfund Amendments and Reauthorization Act (SARA) signed into law on October 17, 1986. The USEPA's document Guidance for Conducting Remedial Investigations and Feasibility Studies Under CERCLA (USEPA, 1988a) has been used as guidance for preparing this document.

This FS has been based on data collected during the RI conducted at Sites 6, 9, and 82 (Baker, 1993). Field investigations at Sites 6, 9, and 82 were conducted from August 1992 and continued through April 1993. Results of the field investigations are summarized in the RI

and Ecological Risk Assessment Reports under separate cover. The following field activities were performed as part of the RI:

- Site surveying
- Test pit excavating
- Geophysical surveying
- Ordnance surveying/removal
- Drum sampling
- Installation of 27 shallow and 13 deep monitoring wells
- Two rounds of groundwater sampling
- Soil sampling
- Surface water and sediment sampling
- Ecological and aquatic sampling

In total, 937 samples were collected from Sites 6, 9, and 82 during the first phase of the RI and analyzed in accordance with Contract Laboratory Program (CLP) protocol, not including quality assurance/quality control (QA/QC) samples. These samples included 49 groundwater samples, 317 surface soil samples, 385 subsurface soil samples, 48 surface water samples, 64 sediment samples, 49 drum samples, 14 subsurface soil samples collected from test pit excavations, and 11 ecological fish samples. Additional groundwater and soil samples were collected during the second phase of the RI.

1.1 Purpose and Organization of the Report

1.1.1 Purpose of the Feasibility Study

The purpose of the FS for OU No. 2 is to select a remedy that: is protective of human health and the environment; attains Federal and State requirements that are applicable or relevant and appropriate; and is cost effective.

In general, the FS process under CERCLA serves to ensure that appropriate remedial alternatives are developed and evaluated, such that relevant information concerning the remedial action options can be presented and an appropriate remedy selected. The FS involves two major phases:

- Development and screening of remedial action alternatives, and
- Detailed analysis of remedial action alternatives.

The first phase includes the following major activities: (1) developing remedial action objectives and remediation goals, (2) developing general response actions, (3) identifying volumes or areas of affected media, (4) identifying and screening potential technologies and process options, (5) evaluating process options, (6) assembling alternatives, (7) defining alternatives, and (8) screening and evaluating alternatives. Section 121(b)(1) of CERCLA requires that an assessment of permanent solutions and alternative treatment technologies or resource recovery technologies that, in whole or in part, will result in a permanent and significant decrease in the toxicity, mobility, or volume of the hazardous substance, pollutant, or contaminant be conducted. In addition, according to CERCLA, treatment alternatives should be developed ranging from an alternative that, to the degree possible, would eliminate the need for long-term management to alternatives involving treatment that would reduce toxicity, mobility, or volume as their principal element. A containment option involving little or no treatment and a no action alternative should also be developed.

The second major phase of the FS consists of: (1) evaluating the potential alternatives in detail with respect to nine evaluation criteria to address statutory requirements and preferences of CERCLA, and (2) performing a comparison analysis of the evaluated alternatives.

1.1.2 Report Organization

This FS Report is organized in six sections. The introduction (Section 1.0) presents the purpose of the report, a brief discussion of the FS process, and pertinent site background information including a summary of the nature and extent of contamination at the operable unit. Section 2.0 contains the remedial action objectives (including remediation goals) that have been established for the operable unit. Section 3.0 contains the identification of general response actions, and the identification and preliminary screening of the remedial action technologies and process options. Section 4.0 contains the development and preliminary screening of remedial action alternatives. Section 5.0 presents the results of the detailed analysis of the remedial alternatives (both individual analysis and comparative analysis). The detailed analysis is based on a set of nine criteria including short- and long-term effectiveness, implementability, cost, state and local acceptance, compliance with applicable

regulations, and overall protection of human health and the environment. The references are listed in Section 6.0.

1.2 Site Background Information

Background information pertaining to OU No. 2 is presented below. Additional details pertaining to the operable unit can be found in the RI Report (Baker, 1993).

1.2.1 Site Description

Camp Lejeune is a training base for the Marine Corps, located in Onslow County, North Carolina (Figure 1-1). The base covers approximately 170 square miles and is bounded to the southeast by the Atlantic Ocean, to the northeast by State Route 24, and to the west by U.S. Route 17. The town of Jacksonville, North Carolina is north of the base.

The study area for this FS is OU No. 2, which consists of Sites 6, 9 and 82. OU No. 2 is located approximately two miles east of the New River and two miles south of State Route 24. In general, OU No. 2 is bounded by Wallace Creek to the north, Holcomb Boulevard to the west, Sneads Ferry Road to the south, and Piney Green Road to the east. OU No. 2 covers an area of approximately 210 acres.

Note that Site 82 was originally referred to as "the wooded area north of Lot 203" in the Final RI/FS Work Plan for OU No. 2. During the RI, it was found that this "wooded area" was previously investigated and named Site 82 - Piney Green Road VOC Area. Therefore, the wooded area will now be properly referred to as Site 82.

The site descriptions for all three sites included under OU No. 2 are presented below. The site plans for Sites 6, 9, and 82 are shown on Figures 1-2 and 1-3.

1.2.1.1 Site 9 Description

Site 9 is the "Fire Fighting Training Pit at Piney Green Road" (also referred to as the "Fire Training Area"). The site covers an area of approximately 2.6 acres. In general, the Site 9 study area is bounded by Holcomb Boulevard on the west, Bear Head Creek approximately 500 feet to the north, Piney Green Road on the east, and Sneads Ferry Road on the south.

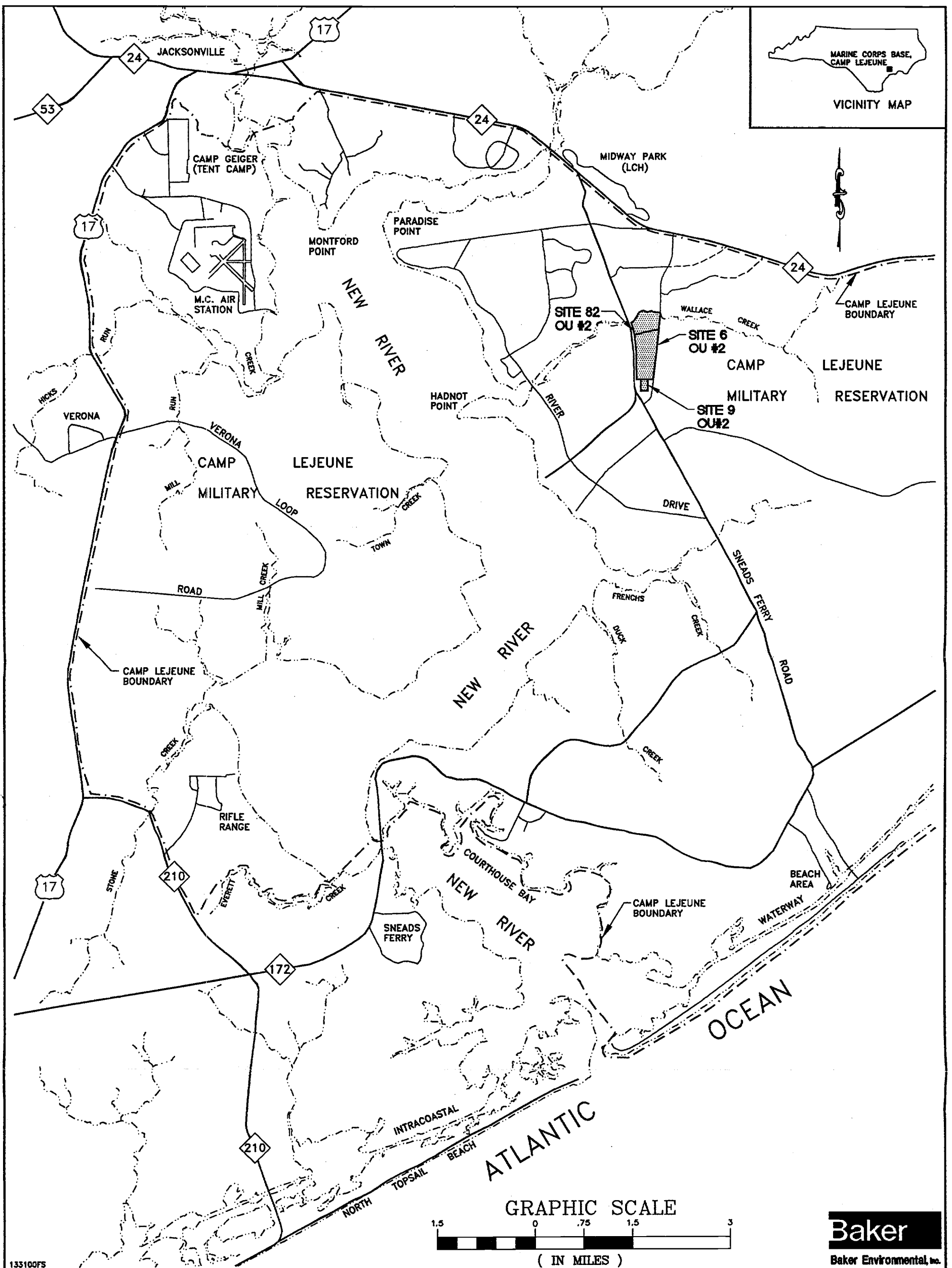

1-5

133100FS

Baker
Baker Environmental, Inc.

FIGURE 1-1
LOCATION MAP
OPERABLE UNIT No.2, SITES 6, 9, and 82
FEASIBILITY STUDY CTO-0133

MARINE CORPS BASE, CAMP LEJEUNE
NORTH CAROLINA

01483 CC B1Z

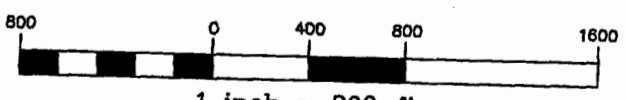
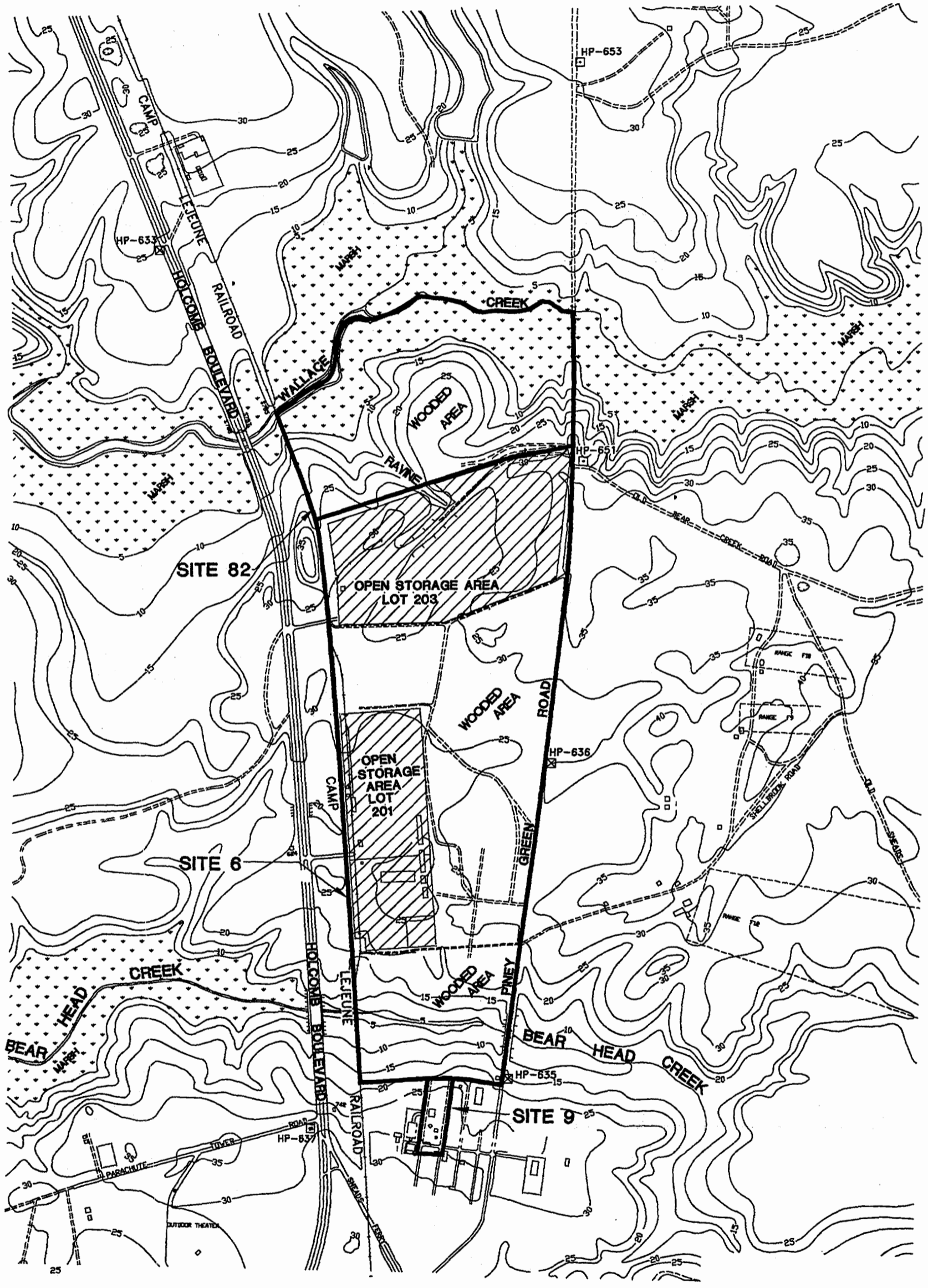

Baker
Baker Environmental, Inc.

153101FS

LEGEND

- APPROXIMATE SITE BOUNDARIES
- ▨ OPEN STORAGE AREA
- UNPAVED ROAD
- HP-635 □ ACTIVE WATER SUPPLY WELL
- HP-653 □ INACTIVE WATER SUPPLY WELL

SOURCE: LANTDIV, FEBRUARY 1992

FIGURE 1-2
SITE PLAN OF SITES 6, 9, and 82
FEASIBILITY STUDY CTO-0133

MARINE CORPS BASE, CAMP LEJEUNE
NORTH CAROLINA

9-1

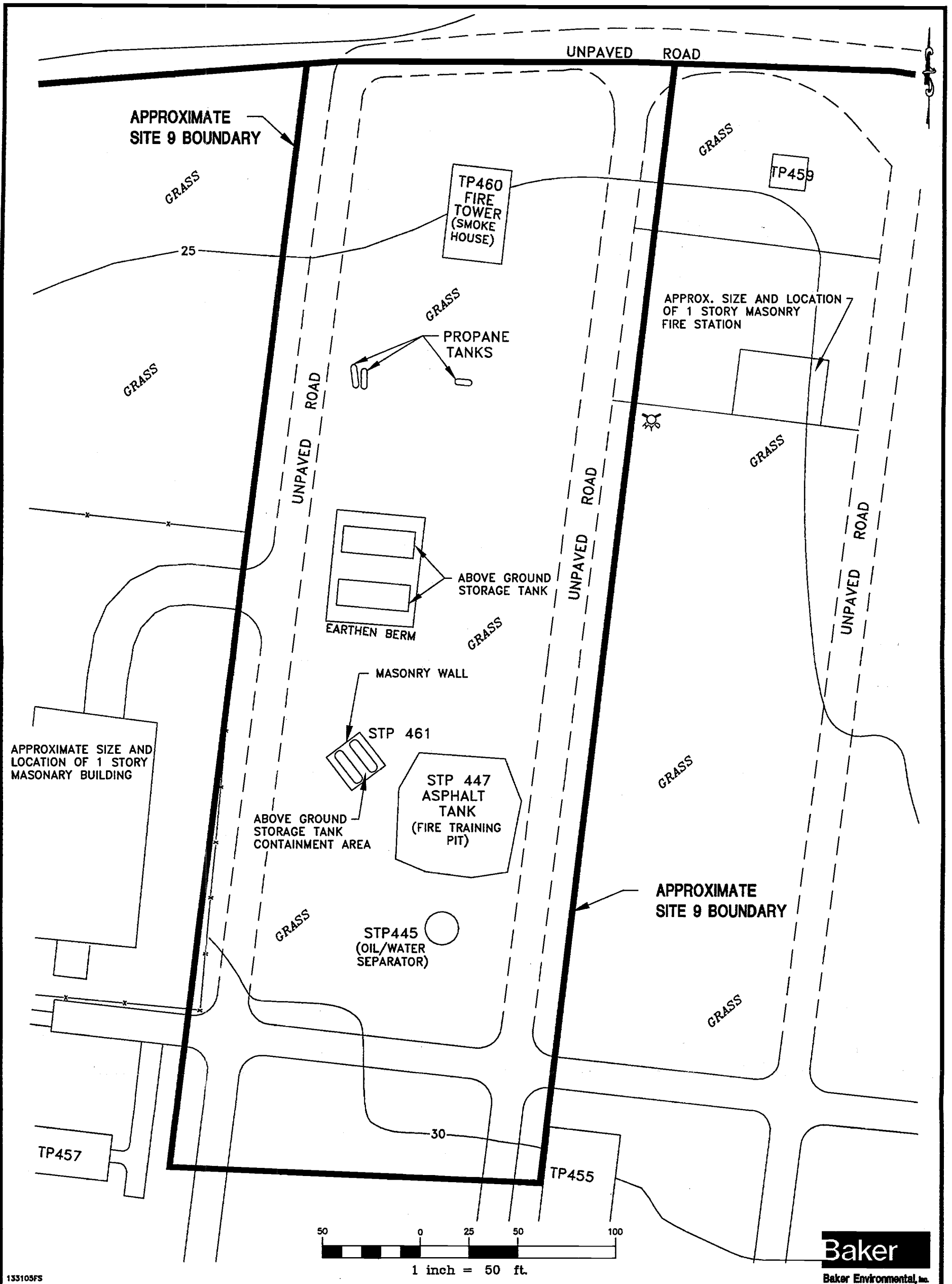

133103FS

FIGURE 1-3
SITE PLAN OF SITE 9
FEASIBILITY STUDY CTO-0133

MARINE CORPS BASE, CAMP LEJEUNE
NORTH CAROLINA

SOURCE: LANTDIV, FEBRUARY 1992

L-1

Locally, the site is bounded by unnamed, unpaved roads leading to various storage buildings in the vicinity. In addition, Site 6 forms the northern boundary of Site 9.

As shown on Figure 1-3, Site 9 consists of an asphalt-lined fire training pit, an oil/water separator, four aboveground storage tanks (ASTs), three propane tanks, and a fire tower (smoke house). The fire training pit, located in the southern area of the site, is used to conduct training exercises for extinguishing fires caused by flammable liquids. The oil/water separator is located next to the fire training pit to collect water used in the training exercises and storm water that falls into the pit. The recovered product collected in the oil/water separator is disposed off site. Two of the ASTs at Site 9 are 2500-gallon steel tanks that are labeled "DO NOT USE." These tanks are not currently in use. Two additional ASTs, located within a concrete containment area, are currently in use. These tanks are constructed of steel and have a capacity of 500 gallons each. The smoke house, located in the northern part of Site 9, is also used for training exercises. No fuel products are used in this area of the site.

1.2.1.2 Site 6 Description

Site 6 is located in between Sites 9 and 82. Site 6 is bounded on the north by Site 82, by Piney Green Road on the east, by Site 9 and woods on the south, and by the Camp Lejeune Railroad (Holcomb Boulevard) on the west. Site 6 covers an area of approximately 177 acres that incorporates Storage Lots 201 and 203, several wooded areas, and the ravine. Three surface water bodies are associated with Site 6 for the purpose of this FS: Wallace Creek, Bear Head Creek, and a ravine located north of Open Storage Lot 203 that drains into Wallace Creek. Specific details of the individual areas that make up Site 6 are described below.

Open Storage Lot 201

Open Storage Lot 201 is a fenced lot located in the south central portion of Site 6 (Figure 1-2). It is a flat area with sparse vegetation around the fence lines. The ground surface is densely compacted soil. Lot 201 is bordered by woods to the north, east, and south, and by the Camp Lejeune Railroad (Holcomb Boulevard) to the west. The lot is approximately 25 acres in size. It is currently being used for the storage of military vehicles and equipment, lumber, hydraulic oils and lubricants, non-polychlorinated biphenyl (PCB) transformers, and other supplies (ESE, 1992).

Open Storage Lot 203

Open Storage Lot 203 is a fenced lot located in the northern portion of Site 6 covering approximately 41 acres (Figure 1-2). Lot 203 is a relatively flat area with elevation differences of approximately five feet. Lot 203 varies in vegetation from a hard compact surface with no vegetation to areas with loose sandy soil and dense vegetation. Lot 203 is bordered by Site 82 and the ravine to the north, Piney Green Road to the east, woods to the south, and by the Camp Lejeune Railroad (Holcomb Boulevard) to the west. Lot 203 is currently inactive, but it still contains randomly stored scrap materials from former activities such as rubber rafts, shredded tires, radio/ communications parts, empty ammunition boxes, spent ammunition casings, fiberglass-like material, barbed wire fencing, used demolition kit training materials, a non-PCB transformer, wooden pallets, metal debris, and 55-gallon drums.

The 55-gallon drums found on Lot 203 were observed in small groupings throughout the lot. The majority of the drums, if labeled, were identified as containing lubricants, petroleum products, or corrosives. Empty storage tanks were also found on Lot 203. They were labeled as containing diesel fuel, gasoline, and kerosene (Baker, 1992).

Ravine Area

A ravine is located in the northwest section of Site 6 (along the northern boundary of Lot 203) and bisects Site 82. The elevation of the ravine ranges from 25 feet above mean sea level (msl) at the north boundary of Lot 203 to 5 feet above msl where the ravine drains into Wallace Creek at Site 82. The surface of the ravine area is littered with various debris including batteries, fencing, tires, empty unlabeled drums, wire cables, commercial ovens, commodes, and respirator cartridges. An empty drum labeled "DDT" (which is dichlorodiphenyl-trichloroethane) was also found in the ravine area as were small canisters labeled "DDT."

Wooded Areas

Woods and open fields surround both Storage Lots 201 and 203 and make up the remaining area of Site 6. The topography of the wooded areas is relatively flat, but localized trenching and mounding is visible west of Piney Green Road. The wooded areas are randomly littered with debris including spent ammunition casings, and empty or rusted drums. Many of the drums observed were only shells or fragments of drums (Baker, 1992).

1.2.1.3 Site 82 Description

Site 82, Piney Green Road VOC Site, is located directly north and adjacent to Site 6. It is bordered to the north by Wallace Creek, to the east by Piney Green Road, to the west by Holcomb Boulevard, and to the south by Site 6. Site 82 encompasses approximately 30 acres and is predominantly covered by woodlands. The ravine previously described in Section 1.2.1.2 bisects the site.

The site is randomly littered with debris including communication wire, spent ammunition casings, and empty or rusted drums. Markings were observed on a few drums, however, most of the drums did not contain markings due to their condition and age. Some of the drums were marked as "lubrication oil" and "antifreeze."

The topography within Site 82 is relatively flat near the southern portion of the site, but becomes very steep near the bank of Wallace Creek. Localized trenching and mounding is visible near the southern portion of the site. A second smaller ravine area is located along the eastern boundary of the site.

1.2.2 **Site History**

The following paragraphs describe the documented history of OU No. 2. Waste storage and disposal activities at the individual sites are described below.

1.2.2.1 Site 9 History

Site 9 has been used as a fire fighting training area from the early 1960s to the present. Fire extinguishing activities took place in an unlined pit. In 1981, the pit was lined with asphalt. The training fires in the pit were started with used oil, solvents, and contaminated fuels (unleaded). Approximately 30,000 to 40,000 gallons of JP-4 and JP-5 fuels were also burned in the fire training pit. Chemical retardants, containing diethylene glycol monobutyl ether, a proprietary mixture of hydrocarbons, fluorosurfactants, and inorganic salts, were used occasionally to extinguish the training fires (Baker, 1992).

1.2.2.2 Site 6 History

Site 6 has a long history of various uses including the disposal and storage of wastes and supplies. This section on the history of Site 6 has been broken down into Storage Lot 201, Storage Lot 203, and the wooded and the ravine areas to simplify the historical descriptions of these areas.

Storage Lot 201

Lot 201 is currently used to store military equipment, vehicles, hydraulic oils, and other "nonhazardous" supplies. Pesticides were reportedly stored in the northeast and southeast corners of the lot. Transformers containing PCBs were reportedly stored in the southwest corner of the lot (Water and Air Research, 1983). No storage or disposal activities have supporting documentation.

Storage Lot 203

Storage Lot 203 has been used as a disposal area since the 1940s, although there has been little documentation on the actual disposal activities. Pesticides were reported to have been stored in a trailer on Lot 203 as well as in the southeast portion of the lot (Memorandum, 17 January 1989). Drums of DDT were found in the southwestern portion of the lot in 1989 (Memorandum, 12 January 1989). Five 55-gallon drums and surrounding soil were containerized and disposed. Former employees at Lot 203 have reported disposal of various chemicals including PCBs, cleaning solvents, electrolytes from used batteries, and waste oils. Lot 203 was also used for the storage and disposal of radio and communication parts, shredded tires, lubricants, petroleum products, corrosives, expended demolition kit training materials, ordnance, sheet metal debris, wire cables, and wooded pallets. Lot 203 is not currently active as a storage or disposal area, but the ground surface is littered with various debris. Empty and full 55-gallon drums were found at various locations on Lot 203.

Lot 203 is currently fenced. From historical photographs, it appears that the fenced boundaries have changed since the lot was in operation.

Wooded and Ravine Areas

The surface of the wooded areas around Lots 201 and 203 is randomly littered with debris including drums, metal storage containers, and rocket cartridges. No organized disposal operations are documented for the wooded areas. A ravine is located on the northern boundary of Lot 203. Based on the deposition of the debris in the ravine, it appears that trucks may have dumped their contents into the ravine from Lot 203.

1.2.2.3 Site 82 History

Site 82 is randomly littered with debris. No organized disposal operations are documented for this site. It appears that the Site 82 area was used for the disposal of miscellaneous debris from Lot 203 (Site 6) since similar items were identified at both sites. Although the name of the site implies the disposal of volatile organic compounds (VOCs), there is no known documentation regarding the quantity or areas of disposal.

1.2.3 Investigation and Study History

In response to the passage of CERCLA, the DoN initiated the Navy Assessment and Control of Installation Pollutants (NACIP) program to identify, investigate, and clean up past hazardous waste disposal sites at Navy installations. The NACIP investigations conducted by the DoN consisted of Initial Assessment Studies (IAS), similar to the USEPA's Preliminary Assessments/Site Investigations (PA/SI) and Confirmation Studies, similar to USEPA's RI/FS. When the Superfund Amendment and Reauthorization Act (SARA) was passed in 1986, the DoN aborted the NACIP program in favor of the Installation Restoration Program (IRP), which adopted the USEPA Superfund procedures.

The following sections summarize the previous investigations performed at OU No. 2.

1.2.3.1 Initial Assessment Study

An IAS was conducted by Water and Air Research, Inc., in 1983. The IAS identified a number of sites at MCB Camp Lejeune as potential sources of contamination, including the sites discussed in this FS. The IAS reviewed historical records and aerial photographs, as well as performing field inspections and personnel interviews to evaluate potential hazards at various

sites on MCB Camp Lejeune. The IAS recommended performing confirmation studies at Sites 6 and 9 to evaluate the necessity of conducting mitigating actions or clean-up operations.

1.2.3.2 Confirmation Study

A Confirmation Study was conducted by Environmental Science and Engineering, Inc. (ESE) in 1984 through 1987. The purpose was to investigate the potential source areas identified in the IAS. The Confirmation Study was divided into two separate reports: a Verification Step conducted in 1984 and a Confirmation Step conducted in 1986 through 1987. Soil, sediment, surface water and groundwater were sampled as part of the Confirmation Study (ESE, 1992). Detailed results of this study can be found in the RI Report for OU No. 2.

1.2.3.3 Soil Gas Survey

A Site Survey Report was prepared by MCB Camp Lejeune in February 1989. The purpose of this survey was to identify the presence of volatile organic compounds using soil gas analysis that may potentially affect personnel working at Storage Lot 203. The survey was conducted by MCB Camp Lejeune personnel.

The results of the testing found that "no imminent hazards were observed" and that all of the tests were negative except for a localized soil stain from a former spill.

1.2.3.4 Site Investigation

A site investigation was conducted at Site 82 in June 1991 by Halliburton NUS Environmental Corporation (NUS). This investigation was initially conducted as part of a study for Site 6. The investigation consisted of drilling six shallow soil borings and installing three shallow monitoring wells; soil and groundwater sampling; and surface water and sediment sampling of Wallace Creek. Organic contamination was detected in all of the media sampled.

During this investigation, it was determined that the source of VOCs detected in Wallace Creek most likely was not from Site 6. Therefore, the area north of Lot 203 was considered a new site, Site 82 (NUS, 1992).

1.2.3.5 Site Assessment

A Site Assessment Report was prepared by ESE in March 1992 (ESE, 1992). This report contained a summary of the Confirmation Study done by ESE at an earlier date and a preliminary risk evaluation for Site 6. The Site Assessment Report recommended that a full human health and ecological risk assessment be performed at Site 6.

1.2.3.6 Remedial Investigation

The Remedial Investigation (RI) field program at OU No. 2 was initiated by Baker Environmental, Inc. to characterize potential environmental impacts and threats to human health resulting from previous storage, operation, and disposal activities. The first phase of investigation activities commenced on August 21, 1992, and continued through November 10, 1992. This first part of the field program consisted of a preliminary site survey; an unexploded ordnance survey; a geophysical survey; a soil investigation including drilling and sampling; a groundwater investigation including monitoring well installation (shallow and deep wells) and sampling; drum waste sampling; test pit sampling; a surface water and sediment investigation; and an aquatic and ecological survey. A second phase of the investigation focused on the groundwater contamination identified at Site 82. The second phase was conducted in early 1993 and completed by April 1993. The results of the RI are summarized below.

Levels of organic contamination including PCBs, pesticides, VOCs, and semivolatile organic compounds (SVOCs) are present throughout OU No. 2 in the various media (i.e., soil, groundwater, surface water, and sediments). Pesticides, PCBs, VOCs, and SVOCs appear to be the predominant contaminants of concern (COCs) in soils (mostly in surface soils) and sediments. VOCs appear to be the COCs in groundwater in both the surficial (less than 25 feet in depth) and deep (greater than 100 feet in depth) portions of the groundwater aquifer. In addition, VOCs appear to be the COCs in the surface water. Several areas were identified within OU No. 2 which exhibited significant levels of organic contamination. These areas are located within Lot 201 [PCBs, pesticides, VOCs, and SVOCs (northeastern corner of lot)], the ravine area (PCBs, pesticides, and SVOCs), Site 82 (VOCs and SVOCs), and Wallace Creek (VOCs). A summary of the organic data collected from OU No. 2 is presented in Appendix A.

Inorganic contaminants are also present throughout OU No. 2 in the various media. The predominant inorganic COCs appear to be barium, cadmium, chromium, lead, manganese,

silver, and zinc. These contaminants were identified in soils above background levels (i.e., compared to normal background levels for Camp Lejeune soils). In some cases, the inorganic contaminants identified in groundwater were detected above the Federal drinking water standards and/or the North Carolina Water Quality Standards. Additionally, several of these contaminants were detected above ambient water quality guidelines. A summary of the inorganic data collected from the RI is presented in Appendix A.

1.2.3.7 Baseline Risk Assessments

Human Health Risk Assessment

Baker conducted a baseline human health risk assessment (RA) for surface soil, groundwater, surface water, sediment and biota at OU No. 2 in 1993. This RA is a component of the RI for OU No. 2. The RA concluded that future potential ingestion of groundwater may potentially result in an increased human health risk to potential future receptors (i.e., child residents, adult residents, civilian base employees). The increase in the potential human health risk from ingestion of groundwater is due to the presence of chlorinated hydrocarbons [e.g., trichloroethene (TCE), vinyl chloride, etc.], and total inorganic concentrations of arsenic and beryllium.

Human health risks associated with soil were within the USEPA target range of 1.0E-4 to 1.0E-6 under existing and future land use scenarios.

Ecological Risk Assessment

A baseline ecological RA was also conducted by Baker in 1993 for OU No. 2. The summary/conclusions for this ecological RA are discussed below with respect to Wallace Creek and Bear Head Creek.

Wallace Creek

Toluene, silver, benzene, phenols, and selenium were detected in fish and crab tissue samples. The fish tissue concentrations were within the range of tissue concentrations for these contaminants reported in ecological studies conducted throughout the United States. Because of the limited database, it cannot be determined whether the contaminants detected in the fish and crab tissues are due to offsite contaminant migration and subsequent bioaccumulation.

The fish community at OU No. 2 had elevated tissue concentrations of the following COCs: pesticides, PCBs, TCE, and zinc. Due to the nature of the COCs, these constituents may be attributed to OU No. 2; however, further studies are required to verify this because of the limited database.

Bear Head Creek

Toluene, cadmium, benzene and selenium were detected in fish and crab tissue samples. The fish tissue concentrations were within the range of tissue concentrations for these contaminants reported in ecological studies. Because of the frequency of detection of these contaminants both upstream and downstream from OU No. 2, the contaminants may not be attributed to the sites.

The fish community in Bear Head Creek had elevated tissue concentrations of the following COCs: pesticides, PCBs, and zinc. Due to the nature of the COCs, these constituents may be attributed to OU No. 2.

1.2.3.8 Time Critical Removal Action

A Time Critical Removal Action is currently in the design phase for the drums and containers located within Sites 6 and 82. The removal activities are scheduled to begin in the winter of 1993. The purpose of the removal action is to remove drums and containers, and five aboveground storage tanks from the sites, as well as containers buried in trenches north and south of Storage Lot 203. The removal action also includes excavating visually contaminated soils from around buried drums and containers, and beneath the aboveground storage tanks.

The general areas where drums, containers and aboveground storage tanks were identified at the sites are shown on Figure 1-4. A summary of the types of storage vessel, the locations, and the known contents of the vessels are listed on Table 1-1.

1.2.4 Nature and Extent of Contamination

Based on the results of the various environmental investigations conducted at OU No. 2 during the RI, conclusions with respect to the nature and extent of contamination at the three sites were developed as listed below. Please note that various drums and containers were

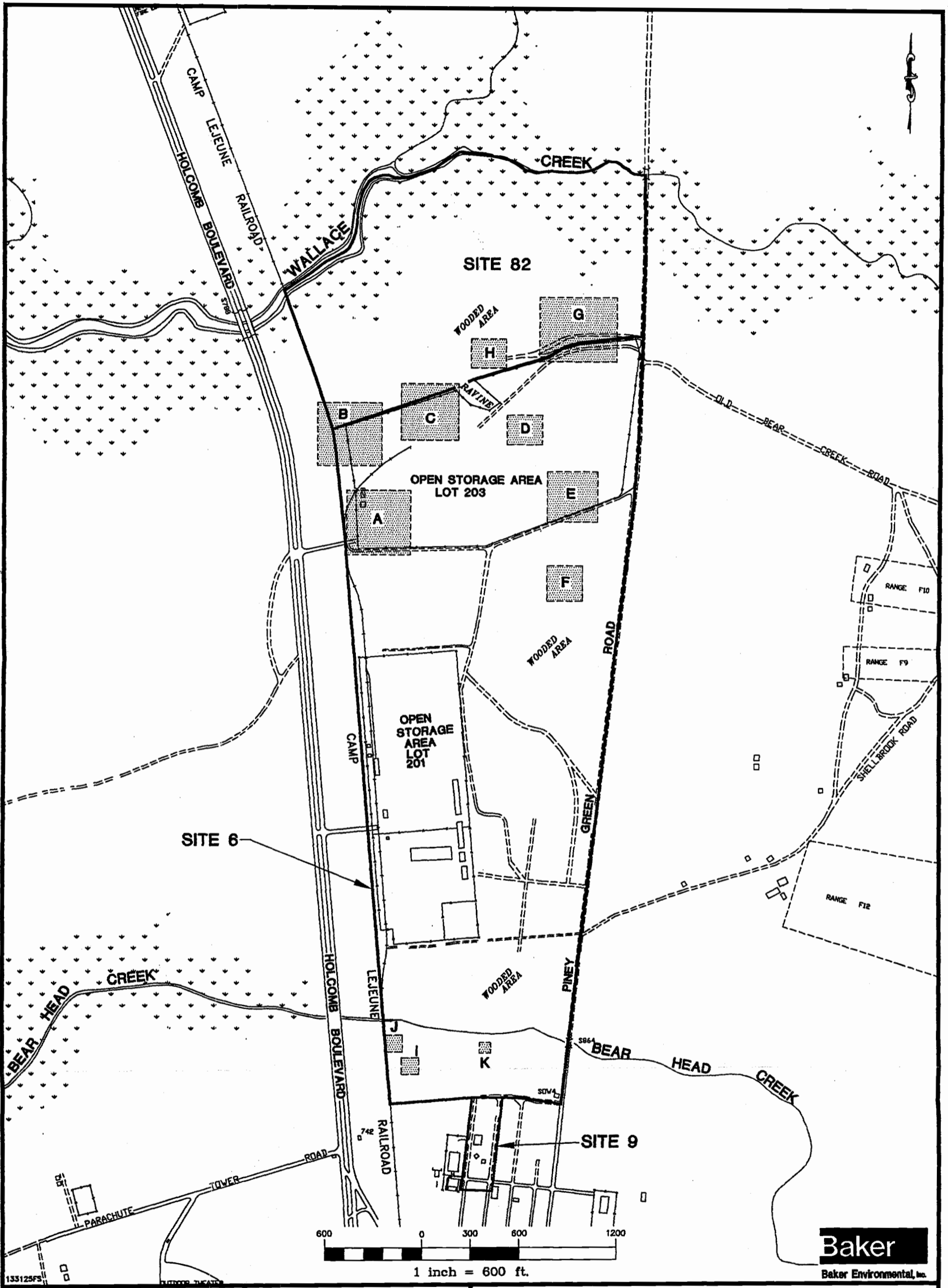

1-17

LEGEND

AREAS OF CONCERN CONTAINING DRUMS, CONTAINERS AND/OR ABOVE GROUND TANKS.

NOTE: REFER TO SECTION 1.2 FOR A DESCRIPTION OF THE CONTENTS OF EACH AREA OF CONCERN.
SOURCE: LANTDIV, FEBRUARY 1992

FIGURE 1-4
TIME CRITICAL REMOVAL ACTION
DRUM LOCATIONS
FEASIBILITY STUDY CTO-0133
MARINE CORPS BASE, CAMP LEJEUNE
NORTH CAROLINA

01483 CC01Z

TABLE 1-1

REMOVAL ACTION DRUM AND CONTAINER SUMMARY
 FEASIBILITY STUDY CTO-0133
 MCB CAMP LEJEUNE, NORTH CAROLINA

Removal Area	Drums and Containers	Contents
A	15 - 55 Gallon Steel Drums (5 empty)	Lubricating Oil Unknown Material
	29 - 10 Gallon Steel Drums (all empty)	
	1 - 5 Gallon Polyethylene Drum	
B	23 - 55 Gallon Steel Drums (20 empty)	Lubricating Oil White Kerosene Kerosene
	3 - 55 Gallon Polyethylene Drums (all empty)	
	4 - 250 Gallon Steel Above Ground Storage Tanks (more than half full)	
	1 - 500 Gallon Steel Above Ground Storage Tank	
C	18 - 55 Gallon Steel Drums (11 empty)	Lubricating Oil Unknown Material
	11 - 65 Gallon Fiberglass Drums (9 empty)	
	1 - 55 Gallon polyethylene Drum (empty)	
D	3 - 55 Gallon Steel Drums	Lubricating Oil Polishing Compound (Pint Containers) Unknown Material
	6 - 5 Gallon Steel Drums	
	650 - 1 Pint Steel Containers (number approximate)	
E	44 - 55 Gallon Steel Drums (35 empty)	Lubricating Oil, Unknown, Hydraulic Fluid, Grade 80 Lubricating Oil, Diesel Fuel
F	11 - 10 Gallon Steel Drums (4 extremely decayed)	Decontaminating Agent Unknown Material
G	12 - 55 Gallon Steel Drums (all empty)	Unknown Material
	2 - 5 Gallon Steel Drums	
H	9 - 55 Gallon Steel Drums (previous investigation - derived wastes, 1 empty)	No samples taken
I	14 - 55 Gallon Steel Drums (11 empty)	Unknown Material
J	8 - 55 Gallon Steel Drums (all empty)	Unknown Material
	2 - 5 Gallon Steel Drums	
K	6 - 55 Gallon Steel Drums (all empty)	No samples taken
Miscellaneous Drums	5 - 55 Gallon Steel Drums (all empty)	No samples taken
Trenches 6-TP5 and 6-TP7	1/2 Gallon to 5 Gallon Containers 5' to 7' Metal Debris Greenish-blue grease material	Resembles No. 6 Fuel Oil
Trenches: GS-1960D and GS-1960E	5 Gallon Containers in poor condition at 2' to 6' deep Communication Wire Metal debris	Unknown Material

noted throughout Sites 6 and 82. All surficial drums/containers and known buried drums are being removed from OU No. 2 through a Time Critical Removal Action which will be conducted prior to implementing any remedial alternative developed in this FS.

Site 9

- Ongoing fire training exercises at Site 9 have not significantly impacted either soil or groundwater quality.
- Low levels of pesticides present at Site 9 are likely the result of former pest control practices and not associated with waste disposal.
- Potential human health risks to military personnel training at Site 9 are within the incremental carcinogenic risk (ICR) range of 1.0E-4 and 1.0E-6.

Site 6 - Lot 201

- The northeast corner of Lot 201 at the former pesticide storage area is contaminated with elevated levels of pesticides that may be associated with former waste storage/handling activities. The extent of soil contamination is limited in area since only two sampling locations exhibited elevated contaminant levels.
- Former waste storage/handling activities at Lot 201 have not adversely impacted groundwater quality in this portion of OU No. 2.
- The presence of low levels of pesticides throughout Lot 201 is indicative of former pest control practices and is probably not associated with the former storage of pesticides. Low levels of pesticides were detected at similar concentrations throughout the entire 210-acre operable unit.
- Reported storage of PCB transformers at Lot 201 has not resulted in significant impacts to soil or groundwater.
- Overall, the current health risk to base personnel working at Lot 201 is within the target range of 1.0E-4 and 1.0E-6.

Site 6 - Lot 203

- Pesticide levels detected in soil at Lot 203 are not indicative of pesticide disposal. Pesticide levels at Lot 203 are comparable to other portions of OU No. 2. The southeast corner of Lot 203 did not reveal elevated pesticide levels given that pesticides were reported to be disposed in this area.
- The area of Lot 203 near the former railroad spur may be associated with previous disposal activities. A limited number of surface and subsurface soil samples collected near the former railroad spur have revealed elevated levels of PCB (Aroclor-1260) and PAHs. Historical aerial photographs indicate significant activity (i.e., surficial anomalies) in this area of Lot 203.
- Disposal activities may have occurred in the north central portion of Lot 203 where elevated levels of PCBs were detected in subsurface soil samples. In addition to PCBs, elevated levels of PAHs were also detected in this area.
- The reported PCB disposal area in the northeast corner of Lot 203 did not reveal elevated levels of PCBs. The reported area may have been inaccurately identified in Marine Corps memorandums.
- Military training operations at Lot 203 resulted in a substantial amount of buried debris including communication wire, shell casings, battery packs, small 5-gallon containers, and bivouac wastes. No 55-gallon drums were uncovered in any of the test pit excavations. Trenches identified in historical photographs were primarily excavated as a means to dispose of military-type wastes and not for purposes of disposing hazardous wastes.
- Numerous drums on the surface of Lot 203 present a potential impact to human health and the environment. Samples collected from these drums indicate that some of the drum contents are characteristically hazardous. None of the drums were noted to be leaking.
- Groundwater quality at Lot 203 has not been significantly impacted by former disposal and storage practices. Trace levels of TCE were detected in well 6GW15, which is located in the north central portion of Lot 203 where disposal activities may

have occurred. Trace levels of TCE and tetrachloroethene (PCE) were detected in well 6GW23.

Well 6GW23 is located in the south central portion of Lot 203. The source of VOC contamination in well 6GW23 is unknown. Soil samples collected from this borehole as well as other nearby soil borings did not indicate a source.

- Currently, Lot 203 is inactive and access is restricted. If the storage lot resumes operations, the potential human health risk (i.e., incremental carcinogenic risk) would be within the target range of 1.0E-4 to 1.0E-6.

Site 6 - Wooded Areas

- PCBs were detected in surface soil near Piney Green Road east of Lot 201. Disposal activities may have occurred in this area, which once served as a training area.
- Disposal activities may have occurred in the wooded area between Lot 201 and 203. One location exhibited moderate levels of PCBs, PAHs, and pesticides in surface soil. The horizontal and vertical extent of this contamination is limited.
- A former disposal area was identified during the test pit investigation in the wooded area between Lot 201 and Lot 203. Numerous 5-gallon containers, bivouac wastes, and battery packs were encountered. All of the containers were rusted and destroyed to the point where their contents could not be identified; however, solvent-like odors were observed by the sampling team. A sample of the sludge material near the containers revealed that the material is characteristically hazardous due to elevated levels of lead. Chloroform was also detected, but was below Toxicity Characteristics Leaching Procedure (TCLP) regulatory levels.
- Groundwater quality in the wooded area south of Lot 203 (near the above-mentioned disposal area) has been impacted by former disposal practices. Low levels of VOCs (chloroform, chlorobenzene, phenol) were encountered in two wells.
- Potential human exposure to soil within the wooded portions of OU No. 2 would not result in significant health risks. ICR values are within the acceptable risk range of 1.0E-4 and 1.0E-6. The area is frequented by hunters and military personnel.

Site 82

- Site 82 exhibited elevated VOC contaminant levels in soil at two locations near the eastern portion of the site. This area is a potential source of VOC contamination in groundwater.
- A large quantity of drums and debris were observed on the surface and subsurface at Site 82 near monitoring wells 6GW1S and 6GW1D. Samples collected of the waste material analyzed the waste as No. 6 fuel oil, which is typically used for heating. Other drums uncovered could not be identified. This area may also be a source of groundwater contamination at Site 82.
- Shallow and deep groundwater within Site 82 exhibited elevated levels of VOC contaminants. Deep groundwater quality was found to be significantly more contaminated than shallow groundwater quality.
- The horizontal extent of shallow groundwater contamination is defined. The plume apparently originates in the southern portion of Site 82 and discharges into Wallace Creek. Contaminants have migrated into the deeper portion of the aquifer as evidenced by elevated VOC levels in deep groundwater monitoring wells.
- The horizontal and vertical extent of deep groundwater contamination has been evaluated. The horizontal extent of off-site contamination west of Site 82 (beyond well 6GW37D), however, has not been fully defined. Moreover, the vertical extent has been evaluated to a depth of 230 feet. It is unknown at this time whether contamination extends below 230 feet. As mentioned previously, a clay layer is present at approximately 230 feet which may impede the vertical migration of contamination. For purposes of conducting the baseline human health and ecological risk assessment, the current deep groundwater database is adequate. For purposes of performing a feasibility study on the deep aquifer, the current database is also adequate to select feasible remedial alternatives. However, additional data points west of Holcomb Boulevard are required to support the design of an alternative which may employ containment/extraction wells. In addition, the extent of groundwater contamination along the clay layer and below the clay layer needs to be evaluated.

Ravine

- None of the TCL organics detected in the ravine exceeded applicable water quality criteria values. Surface water concentrations of aluminum, cadmium, copper, iron, lead, silver, and zinc exceeded the criteria in some of the samples. The exceedances of these TAL inorganics occurred in upstream and/or downstream samples or were infrequent in occurrence.
- The presence of elevated levels of PAHs in soil and low levels of PCBs in sediment in the upper portion of the ravine (i.e., near Lot 203) is most likely due to former disposal practices. This portion of the ravine is filled with debris, including empty and partially-filled 55-gallon drums. In addition, canisters with "DDT" markings were found in the middle section of the ravine (between Lot 203 and Wallace Creek). However, no elevated levels of pesticides were detected in the ravine sediments.
- Soil contamination detected in the ravine has likely migrated to Wallace Creek via surface runoff. Wallace Creek sediments revealed the same constituents detected in ravine soils and sediments.
- Because of the amount of debris and difficulty in accessing the ravine, it is unlikely that human exposure would occur. ICR estimates for the wooded areas and ravine area have indicated that potential human health risks are within the target range of $1.0E-4$ and $1.0E-6$.

Wallace Creek

- The presence of TCE, PCE, and other VOC contaminants in Wallace Creek is due to shallow and possibly deep groundwater discharge.
- Surface runoff from the ravine has impacted sediment quality. Elevated levels of PAHs and PCBs are present in Wallace Creek. These contaminants were also detected in the ravine.
- Pesticides detected in sediment samples may be due to either runoff from the ravine and/or historical pest control spraying practices. The highest levels of pesticides were

detected in two sampling stations that were located just downstream of where the ravine discharges into Wallace Creek.

- None of the organic chemicals of concern detected in Wallace Creek exceeded applicable water quality standards.
- Inorganic levels for aluminum, cadmium, copper, iron, lead, mercury, nickel, silver, and zinc exceeded North Carolina Water Quality Standards and/or USEPA Region IV acute or chronic water quality screening values. Upstream sampling locations also exhibited inorganic levels which exceeded these standards. The presence of inorganic constituents in Wallace Creek may not be associated with OU No. 2 since no source of inorganic contamination is apparent.
- The fish population and diversity in Wallace Creek appears to be healthy, based on population statistics. No anomalies were observed on any of the fish collected during the aquatic survey.
- Some of the fish collected in Wallace Creek exhibited tissue concentrations of PCBs, pesticides, and TCE, which may be attributable to Site 82 and the ravine area. Ingestion of fish taken from Wallace Creek could result in ICRs above the target point of 1.0E-4.

Bear Head Creek

- Sediment quality in Bear Head Creek may be impacted via surface runoff from the wooded areas. Low levels of PAHs, pesticides, and PCBs were detected in sampling stations which border Site 6. VOC contaminants were also detected in sediment samples; however, the source of VOC contamination unknown given that soil and groundwater in this area was not contaminated with VOCs. Pesticides in sediment are not likely associated with disposal practices.
- Inorganic constituents detected in sediment are not likely the result of disposal practices at Sites 6 or 9.

- The fish community at Bear Head Creek appears to be healthy, based on population statistics and observations. None of the fish collected at Bear Head Creek exhibited lesions or other anomalies that would represent adverse conditions.
- The fish community in Bear Head Creek had elevated levels of pesticides, PCBs, and zinc in tissue. The presence of these contaminants in fish tissue may be the result of contaminated sediment. Ingestion of fish taken from Bear Head Creek could result in ICRs above 1.0E-4.

2.0 DEVELOPMENT OF REMEDIAL ACTION OBJECTIVES

This section presents the development of the remedial action objectives for OU No. 2. Remedial action objectives are medium-specific or operable unit-specific goals established for the protection of human health and environment. There are several steps involved in developing these objectives for a site including identifying the contaminants of concern (COCs); identifying routes of exposure and receptors; and establishing an acceptable contaminant level or range of levels for each exposure route (i.e., the remediation goals). The development of the remedial action objectives via these steps are detailed in the following three sections. The resulting set of remedial action objectives are summarized in Section 2.4.

2.1 Contaminants of Concern

The results of the RAs (baseline human health and ecological) presented in the RI Report (Baker, 1993) indicated that groundwater was the media of concern, with respect to carcinogenic and noncarcinogenic risks. The other media (soil, sediment, surface water, and air) had incremental cancer risk (ICRs) less than $1.0E^{-4}$ and hazard indices (HIs) less than 1.0. Therefore, the primary focus of this FS is on groundwater remediation. Soil was added as a media of concern for this FS due to a limited number of areas exhibiting elevated levels of contaminants (hot spots) such as PCBs, pesticides, and VOCs. Note that for the entire operable unit, the reasonable maximum exposure (RME) by more than one pathway does not pose an unacceptable risk to human health or the environment.

Surface water, sediments, and air do not appear to be media of concern, based on the conclusions drawn by the human health and ecological risk assessments. Although contaminants were present in both media, neither media will be directly remediated since the result may be a greater risk to the environment. However, remediation of the source of surface water and sediment contamination (i.e., groundwater and soil, respectively) may result in reducing the surface water and sediment contaminant levels over time.

Preliminary COCs initially identified and evaluated in the RAs were identified based on frequency of detection, toxicity, and comparison to established criteria or standards. The set of preliminary COCs identified for groundwater and soil is listed in Table 2-1. The detected concentrations of these preliminary COCs will be compared to the remediation goals that will be developed in Section 2.3. Any COC that does not exceed the applicable regulatory or health based remediation goals will be eliminated from the set of COCs. In addition, an evaluation

TABLE 2-1

PRELIMINARY CONTAMINANTS OF CONCERN
 FEASIBILITY STUDY CTO-0133
 MCB CAMP LEJEUNE, NORTH CAROLINA

Media	Contaminant of Concern Evaluated in the RA ⁽¹⁾	Preliminary Contaminant of Concern for the FS ⁽²⁾	Media	Contaminant of Concern Evaluated in the RA ⁽¹⁾	Preliminary Contaminant of Concern for the FS ⁽²⁾
Groundwater	Bromodichloromethane	X	Soil	1,4-Dichlorobenzene	X
	Chlorobenzene	X		Benzene	X
	1,2-Dichloroethane	X		1,2-Dichloroethene	X
	1,1-Dichloroethene	X		1,1,2,2-Tetrachloroethane	X
	Trans-1,2-Dichloroethene	X		1,1,1-Trichloroethane	X
	Ethylbenzene	X		Trichloroethene	X
	1,1,2,2-Tetrachloroethane	X		Tetrachloroethene	X
	Tetrachloroethene	X		Chrysene	X
	1,1,1-Trichloroethane	X		Acenaphthene	X
	1,1,2-Trichloroethane	X		Phenanthrene	
	Trichloroethene	X		Anthracene	X
	Vinyl Chloride	X		Fluoranthene	X
	Xylenes	X		Pyrene	X
	Phenol	X		Benzo(a)anthracene	X
	Antimony	X		Benzo(b)fluoranthene	X
	Arsenic	X		Benzo(k)fluoranthene	X
	Barium	X		Benzo(a)pyrene	X
	Beryllium	X		Indeno(1,2,3-cd)pyrene	X
	Chromium	X		Dibenzo(a,h)anthracene	
	Copper	X		4,4'-DDD	X
	Lead	X		4,4'-DDE	X
Manganese	X	4,4'-DDT		X	
Mercury	X	Dieldrin		X	
Nickel	X	Endrin			
Vanadium	X	PCB-1260		X	
Zinc	X	Arsenic		X	
		Barium		X	
		Beryllium		X	
		Cadmium		X	
		Chromium		X	
		Lead		X	
		Manganese		X	
		Nickel		X	
		Vanadium			
		Zinc	X		

- (1) This list includes all of the potential contaminants of concern evaluated in the Risk Assessment (Baker, 1993).
- (2) The determination of the set of preliminary contaminants of concern for the FS was based on two criteria: (1) the contaminant was found to be a contaminant of concern from the results of the RA, or (2) standards and/or criteria are established for the contaminant.

will be conducted on the remaining set of contaminants to determine areas and media of concern for the operable unit. A final set of COCs will be identified which then will be the basis for a set of remedial action objectives applicable to the operable unit.

2.2 Routes of Exposure and Receptors

The results of the human health and the ecological RAs indicated that the exposure routes of concern for groundwater and soil include:

- Ingestion of groundwater
- Inhalation of particulates
- Incidental ingestion of soil
- Dermal contact with soil

Current receptors to these exposures routes would include adult base personnel and wildlife (terrestrial and aquatic). Future potential receptors would include adult and children as residents.

2.3 Preliminary Remediation Goals

Preliminary remediation goals are established based on information such as Federal and State criteria or risk-based action levels. Potential Federal and State criteria for OU No. 2 will be identified and evaluated in Section 2.3.1. Site specific risk-based action levels for the COCs at OU No. 2 will be developed in Section 2.3.2. The results from both of these sections will be used to develop the initial set of preliminary remediation goals for the operable unit (Section 2.3.3).

2.3.1 Applicable or Relevant and Appropriate Federal and State Requirements

Under Section 121(d)(1) of CERCLA, remedial actions must attain a degree of cleanup which assures protection of human health and the environment. Additionally, CERCLA remedial actions that leave any hazardous substances, pollutants, or contaminants on site must meet, upon completion of the remedial action, a level or standard of control that at least attains standards, requirements, limitations, or criteria that are "applicable or relevant and appropriate" under the circumstances of the release. These requirements are known as

"ARARs" or applicable or relevant and appropriate requirements. ARARs are derived from both Federal and State laws. CERCLA's definition of "Applicable Requirements" is:

...cleanup standards, standards of control, or other substantive environmental protection requirements, criteria, or limitations promulgated under Federal or State law that specifically address a hazardous substance, pollutant or contaminant, remedial action, location, or other circumstance at a CERCLA site. Drinking water criteria may be an applicable requirement for a site with contaminated groundwater that is used as a drinking water source.

CERCLA's definition of "Relevant and Appropriate Requirements" is:

...cleanup standards, standards of control and other substantive environmental protection requirements, criteria, or limitations promulgated under Federal or State law that, while not "applicable" to a hazardous substance, pollutant, contaminant, remedial action, location, or other circumstance at a CERCLA site, address problems or situations sufficiently similar to those encountered at the CERCLA site that their use is well suited to the particular site.

There are three types of ARARs. The first type, chemical-specific ARARs are requirements which set health or risk-based concentration limits or ranges for specific hazardous substances, pollutants, or contaminants. Maximum Contaminant Levels (MCLs) established under the Safe Drinking Water Act (SDWA) are examples of chemical-specific ARARs.

The second type of ARARs, location-specific, set restrictions on activities based upon the characteristics of the site and/or the nearby suburbs. Examples of this type of ARAR include Federal and State siting laws for hazardous waste facilities and sites on the National Register of Historic Places.

The third classification of ARARs, action-specific, refers to the requirements that set controls or restrictions on particular activities related to the management of hazardous substances, pollutants, or contaminants. RCRA regulations for closure of hazardous waste storage units, RCRA incineration standards, and pretreatment standards under the Clean Water Act (CWA) for discharges to publicly owned treatment works (POTWs) are examples of action specific ARARs.

Subsection 121(d) of CERCLA requires that Federal and State substantive requirements that qualify as ARARs be complied with by remedies. Federal, State, or local permits do not need to be obtained for removal or remedial actions implemented on site but their substantive requirement must be obtained. "On site" is interpreted by the USEPA to include the a real extent of contamination and all suitable areas in reasonable proximity to the contamination necessary for implementation of the response action.

ARARs can be identified only on a site-specific basis. They depend on the detected contaminants at a site, specific site characteristics, and particular remedial actions proposed for the site. Potential ARARs identified for OU No. 2 are presented in the following section.

2.3.2 Potential ARARs Identified for OU No. 2

A set of chemical-specific, location-specific, and action-specific ARARs were identified and evaluated for OU No. 2 and are discussed below.

2.3.2.1 Chemical-Specific ARARs

Potential chemical-specific ARARs identified for the preliminary COCs for OU No. 2 are listed on Table 2-2. These ARARs were based on the following: the Federal MCLs, the North Carolina Water Quality Standards (NCWQSs) applicable to groundwaters, Federal risk-based Health Advisories (HAs), the PCB Spill Cleanup Policy Under the Toxic Substances Control Act (TSCA), Federal Ambient Water Quality Criteria (AWQCs), and the NCWQSs applicable to surface waters. A brief description of each these standards is presented below.

Federal Maximum Contaminant Levels - MCLs are enforceable standards for public water supplies promulgated under the SDWA and are designed for the protection of human health. MCLs are based on laboratory or epidemiological studies and apply to drinking water supplies consumed by a minimum of 25 persons. These standards are designed for prevention of human health effects associated with a lifetime exposure (70-year lifetime) of an average adult (70 kg) consuming 2 liters of water per day. MCLs also consider the technical feasibility of removing the contaminant from the public water supply. As shown in Table 2-2, MCLs have been established for 22 of the 26 groundwater COCs.

North Carolina Water Quality Standards (Groundwater) - Under the North Carolina Administrative Code (NCAC), Title 15A, Subchapter 2L, Section .0200, (15A NCAC 2L.0200)

POTENTIAL CONTAMINANT-SPECIFIC ARARs
FEASIBILITY STUDY CTO-0133
MCB CAMP LEJEUNE, NORTH CAROLINA

Groundwater Contaminant of Concern	Groundwater ARAR				Soil Contaminant of Concern	Soil ARAR
	MCL ⁽¹⁾ (µg/L)	NCWQS ⁽²⁾ (µg/L)	Federal Health Advisories ⁽³⁾ (µg/L)			
			For a 10 kg Child	For a 70 kg Adult		
Bromodichloromethane	100	-- ⁽⁵⁾	1,000	5,000	PCBs - small spill/low concentrations	visual
Chlorobenzene	--	300	--	--	PCBs - non-restricted access area	10 mg/kg
1,2-Dichloroethane	5	0.38	700	2,600	PCBs - industrial area	25 mg/kg
1,1-Dichloroethene	7	7	2,000	4,000	1,4-Dichlorobenzene	--
Trans-1,2-Dichloroethene	100	70	20,000	6,000	Benzene	--
Ethylbenzene	700	29	30,000	3,000	1,2-Dichloroethene	--
1,1,2,2-Tetrachloroethane	--	--	--	--	1,1,2,2-Tetrachloroethane	--
Tetrachloroethene	5	0.7	2,000	5,000	1,1,1-Trichloroethane	--
1,1,1-Trichloroethane	200	200	10,000	10,000	Trichloroethene	--
1,1,2-Trichloroethane	5	--	600	1,000	Tetrachloroethene	--
Trichloroethene	5	2.8	--	--	PAHs ⁽⁷⁾	--
Vinyl Chloride	2	0.015	3,000	50	4,4'-DDD	--
Xylenes	10,000	400	40,000	100,000	4,4'-DDE	--
Phenol	--	--	6,000	20,000	4,4'-DDT	--
Antimony	6	--	15	15	Dieldrin	--
Arsenic	50	50	--	--	Arsenic	--
Barium	2,000	1,000	--	--	Barium	--
Beryllium	4	--	30,000	20,000	Beryllium	--
Chromium	100	50	1,000	800	Cadmium	--
Copper	1,300 ⁽⁶⁾	1,000	--	--	Chromium	--
Lead	15 ⁽⁶⁾	50	--	--	Lead	--
Manganese	50	50	--	--	Manganese	--
Mercury	2	1.1	--	2	Nickel	--
Nickel	100	150	1,000	1,700	Zinc	--
Vanadium	--	--	80	110		
Zinc	5,000	5,000	--	--		

- (1) MCL = Safe Drinking Water Act Maximum Contaminant Level (also includes nonenforceable Secondary MCLs).
- (2) NCWQS = North Carolina Water Quality Standards for Class GA Groundwaters.
- (3) Health Advisories - Nonenforceable guidelines.
- (4) TSCA = Toxic Substance Control Act.
- (5) -- = No ARAR available or established.
- (6) The MCL for this compound is an action level only.
- (7) The PAHs which are soil COCs include chrysene, acenaphthene, anthracene, fluoranthene, pyrene, benzo(a)anthracene, benzo(b)fluoranthene, benzo(k)fluoranthene, benzo(a)pyrene, and indeno(1, 2, 3-cd)pyrene.

the North Carolina Department of Environment, Health, and Natural Resources (NC DEHNR) has established groundwater standards (NCWQSSs) for three classifications of groundwater within the State: GA, GSA, and GC. Class GA waters are those groundwaters in the State naturally containing 250 milligram per liter (mg/L) or less of chloride. These waters are an existing or potential source of drinking water supply for humans. Class GSA waters are those groundwaters in the State naturally containing greater than 250 mg/L of chloride. These waters are an existing or potential source of water supply for potable mineral water and conversion to fresh water. Class GC water is defined as a source of water supply for purposes other than drinking. The NCAC T15A:02L.0300 has established sixteen river basins within the State as Class GC groundwaters (15A NCAC 2L.0201 and 2L.0300).

The water quality standards for the groundwaters are the maximum allowable concentrations resulting from any discharge of contaminants to the land or water of the State, which may be tolerated without creating a threat to human health or which would otherwise render the groundwater unsuitable for its intended best usage. If the water quality standard of a substance is less than the limit of detectability, the substance shall not be permitted in detectable concentrations. If naturally occurring substances exceed the established standard, the standard will be the naturally occurring concentration as determined by the State. Substances which are not naturally occurring and for which no standard is specified is not permitted in detectable concentrations for Class GA or Class GSA groundwaters (15A NCAC 2L.0202).

The NCWQSSs for substances in Class GA and Class GSA groundwaters are established as the lesser of:

- Systemic threshold concentration (based on reference dose and average consumption)
- Concentration which corresponds to an incremental lifetime cancer risk of $1.0E^{-6}$
- Taste threshold limit value
- Odor threshold limit value
- MCL
- National Secondary Drinking Water Standard

Note that the water quality standards for Class GA and Class GSA groundwaters are the same except for chloride and total dissolved solids concentrations (15A NCAC 2L.0202).

The Class GA groundwater NCWQSSs for the groundwater COCs for OU No. 2 are listed on Table 2-2. As shown on the table, the majority of the State standards are the same or more stringent than the Federal MCLs.

Federal Health Advisories (HAs) - Federal HAs are guidelines developed by the USEPA Office of Drinking Water for nonregulated constituents in drinking water. These guidelines are designed to consider both acute and chronic toxic effects in children (assumed body weight 10 kg) who consume 1 liter of water per day or in adults (assumed body weight 70 kg) who consume 2 liters of water per day. HAs are generally available for acute (1 day), subchronic (10 days), and chronic (longer-term) exposure scenarios. These guidelines are designed to consider only threshold effects and, as such, are not used to set acceptable levels of potential human carcinogens.

Long-term HAs for the groundwater COCs listed in Table 2-2 are included for both a child (10 kg) and an adult (70 kg).

Toxic Substances Control Act - The PCB Spill Cleanup Policy (40 CFR 761.120 through 761.139) describes the level of cleanup required for PCB spills occurring after May 4, 1987. Because this policy is not a regulation and applies only to recent spills, the Spill Policy is not an ARAR for CERCLA response actions. However, as a codified policy representing substantial scientific and technical evaluation, it has been considered in developing the guidance cleanup levels for PCB contamination at CERCLA sites (USEPA, 1990a). A summary of the policy with respect to soil contamination follows.

For spills of low concentration PCBs (50 ppm to 500 ppm) involving less than one pound of PCBs, all soils within the spill areas plus a one-foot lateral boundary must be excavated. The excavation must be backfilled with clean (less than 1 ppm PCB) soil. No confirmation sampling is required (USEPA, 1990a).

For spills of 500 ppm or greater PCBs and spills of low concentration PCBs or more than one pound PCBs by weight in nonrestricted access areas, soil must be cleaned up to 10 ppm PCBs. In addition, a cap of at least 10 inches of clean material must be placed on top of the excavation. Confirmation sampling is required (USEPA, 1990a).

For spills of 500 ppm or greater PCBs and spills of low concentration PCBs of more than one pound in industrial and other restricted access areas, cleanup of soil to 25 ppm is required. Confirmation sampling is required (USEPA, 1990a).

These PCB-specific ARARs are listed in Table 2-2 with respect to contaminated soil.

2.3.2.2 Location-Specific ARARs

Potential location-specific ARARs identified for OU No. 2 are listed on Table 2-3. An evaluation determining the applicability of these location-specific ARARs with respect to OU No. 2 is also presented and summarized on Table 2-3. Based on this evaluation, specific sections of the following location-specific ARARs may be applicable to OU No. 2:

- Fish and Wildlife Coordination Act
- Federal Endangered Species Act
- North Carolina Endangered Species Act
- Executive Order 11990 on Protection of Wetlands
- Executive Order 11988 on Floodplain Management
- RCRA Location Requirements

Please note that the citations listed on Table 2-3 should not be interpreted to indicate that the entire citation is an ARAR. The citation listing is provided on the table as a general reference.

2.3.2.3 Action-Specific ARARs

Action-specific ARARs are typically evaluated following the development of alternatives since they are dependent on the type of action being considered. Therefore, at this step in the FS process, potential action-specific ARARs have only been identified and not evaluated for OU No. 2. A set of potential action-specific ARARs are listed on Table 2-4. These ARARs are based on RCRA, CWA, SDWA, Occupational Safety and Health Act (OSHA), and Department of Transportation (DOT) requirements. Note that the citations listed on Table 2-4 should not be interpreted to indicate that the entire citation is an ARAR. The citation listing is provided on the table as a general reference.

TABLE 2-3

**POTENTIAL LOCATION-SPECIFIC ARARs EVALUATED
FOR OPERABLE UNIT NO. 2
FEASIBILITY STUDY CTO-0133
MCB CAMP LEJEUNE, NORTH CAROLINA**

Potential Location-Specific ARAR	General Citation	ARAR Evaluation
National Historic Preservation Act of 1966 - requires action to take into account effects on properties included in or eligible for the National Register of Historic Places and to minimize harm to National Historic Landmarks.	16 USC 470, 40 CFR 6.301(b), and 36 CFR 800	No known historic properties are within or near OU No. 2, therefore, this act will not be considered as an ARAR.
Archeological and Historic Preservation Act - establishes procedures to provide for preservation of historical and archeological data which might be destroyed through alteration of terrain.	16 USC 469, and 40 CFR 6.301(c)	No known historical or archeological data is known to be present at the sites, therefore, this act will not be considered as an ARAR.
Historic Sites, Buildings and Antiquities Act - requires action to avoid undesirable impacts on landmarks on the National Registry of Natural Landmarks.	16 USC 461467, and 40 CFR 6.301(a)	No known historic sites, buildings or antiquities are within or near OU No. 2, therefore, this act will not be considered as an ARAR.
Fish and Wildlife Coordination Act - requires action to protect fish and wildlife from actions modifying streams or areas affecting streams.	16 USC 661-666	Wallace Creek and Bear Head Creek are located within the operable unit boundaries. If remedial actions are implemented that modify these creeks, this will be an applicable ARAR.
Federal Endangered Species Act - requires action to avoid jeopardizing the continued existence of listed endangered species or modification of their habitat.	16 USC 1531, 50 CFR 200, and 50 CFR 402	Many protected species have been sited near and on MCB Camp Lejeune such as the American alligator, the Bachmans sparrow, the Black skimmer, the Green turtle, the Loggerhead turtle, the piping plover, the Red-cocaded woodpecker, and the rough-leaf loosestrife (LeBlond, 1991),(Fussell, 1991),(Walters, 1991). In addition, the alligator has been sighted in Wallace Creek. Therefore, this will be considered as an ARAR.

TABLE 2-3 (Continued)

**POTENTIAL LOCATION-SPECIFIC ARARs EVALUATED
FOR OPERABLE UNIT NO. 2
FEASIBILITY STUDY CTO-0133
MCB CAMP LEJEUNE, NORTH CAROLINA**

Potential Location-Specific ARAR	General Citation	ARAR Evaluation
North Carolina Endangered Species Act - per the North Carolina Wildlife Resources Commission. Similar to the Federal Endangered Species Act, but also includes State special concern species, State significantly rate species, and the State watch list.	GS 113-331 to 113-337	Since the American alligator has been sighted in Wallace Creek, this will be considered as an ARAR.
Rivers and Harbors Act of 1899 (Section 10 Permit) - requires permit for structures or work in or affecting navigable waters.	33 USC 403	No remedial actions will affect the navigable waters of the New River. Therefore, this act will not be considered as an ARAR.
Executive Order 11990 on Protection of Wetlands - establishes special requirements for Federal agencies to avoid the adverse impacts associated with the destruction or loss of wetlands and to avoid support of new construction in wetlands if a practicable alternative exists.	Executive Order Number 11990, and 40 CFR 6	Based on a review of Wetland Inventory Maps, both Wallace Creek and Bear Head Creek have areas of wetlands. Therefore, this will be an applicable ARAR.
Executive Order 11988 on Floodplain Management - establishes special requirements for Federal agencies to evaluate the adverse impacts associated with direct and indirect development of a floodplain.	Executive Order Number 11988, and 40 CFR 6	Based on the Federal Emergency Management Agency's Flood Insurance Rate Map for Onslow County, Sites 6 and 9 are primarily within a minimal flooding zone (outside the 500-year floodplain). The immediate areas around Wallace Creek and Bear Head Creek are within the 100-year floodplain (FEMA, 1987). Therefore, this may be an ARAR for the operable unit.
Wilderness Act - requires that federally owned wilderness area are not impacted. Establishes nondegradation, maximum restoration, and protection of wilderness areas as primary management principles.	16 USC 1131, and 50 CFR 35.1	No known federally owned wilderness areas near the operable unit, therefore, this act will not be considered as an ARAR.

TABLE 2-3 (Continued)

**POTENTIAL LOCATION-SPECIFIC ARARs EVALUATED
FOR OPERABLE UNIT NO. 2
FEASIBILITY STUDY CTO-0133
MCB CAMP LEJEUNE, NORTH CAROLINA**

Potential Location-Specific ARAR	General Citation	ARAR Evaluation
National Wildlife Refuge System - restricts activities within a National Wildlife Refuge.	16 USC 668, and 50 CFR 27	No known National Wildlife Refuge areas near the operable unit, therefore, this will not be considered as an ARAR.
Scenic Rivers Act - requires action to avoid adverse effects on designated wild or scenic rivers.	16 USC 1271, and 40 CFR 6.302(e)	No known wild or scenic rivers near the operable unit, therefore, this act will not be considered as an ARAR.
Coastal Zone Management Act - requires activities affecting land or water uses in a coastal zone to certify noninterference with coastal zone management.	16 USC 1451	No activities will affect land or water uses in a coastal zone, therefore, this act will not be considered as an ARAR.
Clean Water Act (Section 404) - prohibits discharge of dredged or fill material into wetland without a permit.	33 USC 404	No actions to discharge dredged or fill material into wetlands will be considered for the operable unit, therefore, this act will not be considered as an ARAR.
RCRA Location Requirements - limitations on where on-site storage, treatment, or disposal of RCRA hazardous waste may occur.	40 CFR 264.18	These requirements may be applicable if the remedial actions for the operable unit includes the on-site storage, treatment, or disposal of RCRA hazardous waste. Therefore, these requirements may be an applicable ARAR for the operable unit.

TABLE 2-4

POTENTIAL ACTION-SPECIFIC ARARs
 FEASIBILITY STUDY CTO-0133
 MCB CAMP LEJEUNE, NORTH CAROLINA

<u>Standard</u>	<u>Action</u>	<u>General Citation</u>
RCRA	Capping	40 CFR 264
	Closure	40 CFR 264, 244
	Container Storage	40 CFR 264, 268
	New Landfill	40 CFR 264
	New Surface Impoundment	40 CFR 264
	Dike Stabilization	40 CFR 264
	Excavation, Groundwater Diversion	40 CFR 264, 268
	Incineration	40 CFR 264, 761
	Land Treatment	40 CFR 264
	Land Disposal	40 CFR 264, 268
	Slurry Wall	40 CFR 264, 268
	Tank Storage	40 CFR 264, 268
Treatment	40 CFR 264, 265, 268; 42 USC 6924; 51 FR 40641; 52 FR 25760	
	Waste Pile	40 CFR 264, 268
CWA	Discharge to Water of United States	40 CFR 122, 125, 136
	Direct Discharge to Ocean	40 CFR 125
	Discharge to POTW	40 CFR 403, 270
	Dredge/Fill	40 CFR 264; 33 CFR 320-330; 33 USC 403
SDWA	Underground Injection Control	40 CFR 144, 146, 147, 268
TSCA	PCB Regulations	40 CFR 761
OSHA	OSHA Requirements for Workers Safety	29 CFR 1910
	OSHA Act of 1970	29 USC 651
DOT	DOT Rules for Transportation	49 CFR 107

These ARARs will be evaluated after the remedial action alternatives have been identified for OU No. 2. Additional action-specific ARARs may also be identified and evaluated at that time.

2.3.3 Site-Specific Risk-Based Action Levels

Site-specific risk-based action levels will be developed for many of the groundwater and soil COCs in this section of the Feasibility Study. Derived action levels for OU No. 2 involved establishing acceptable human health risk criteria and determining allowable risk to COCs, which were then used to back calculate media-specific concentrations for established risk levels.

The methodology used for the derived action levels was in accordance with USEPA risk assessment guidance (USEPA, 1989a) (USEPA, 1991a). For noncarcinogenic effects, a concentration was calculated that corresponds to a hazard index (HI) of 1 or unity, which is the level of exposure to a contaminant from all significant exposure pathways in a given medium below which it is unlikely for even sensitive populations to experience health effects. For carcinogenic effects, a concentration was calculated that corresponds to $1.0E^{-4}$ (one in ten thousand) ICR over a lifetime as a result of exposure to the potential carcinogen from all significant exposure pathways for a given medium. A $1.0E^{-4}$ risk level was used as an end point for determining action levels for remediation. Based on the NCP (40 CFR 300.430), for known or suspected carcinogens, acceptable exposure levels are generally concentrations that represent an ICR between $1.0E^{-4}$ and $1.0E^{-6}$. The action levels are representative of acceptable incremental risks at the evaluated site based on current and probable future use of the area. Based on the Master Plan for MCB Camp Lejeune, the area encompassing OU No. 2 will likely remain the same (i.e., fire training will continue at Site 9, Lots 201 and 203 will be used for open storage, and the wooded areas and Site 82 will be used for training/recreation, or converted into additional storage areas).

Three steps were involved in estimating the risk-based action levels for OU No. 2 COCs. These steps are generally conducted for each medium and land-use combination and involved identifying the most significant: (1) exposure pathways and routes, (2) exposure parameters, and (3) equations. The equations included calculations of total intake from a given medium and were based on identified exposure pathways and associated parameters.

The development of the site-specific risk-based action levels for OU No. 2 were determined from a risk evaluation assessment and from a soil/water partitioning approach as presented in the sections that follow.

2.3.3.1 Risk Evaluation Assessment

The determination of medium-specific risk-based action levels was performed in accordance with USEPA guidance (USEPA, 1989a). Reference doses (RfDs) were used to evaluate noncarcinogenic action levels, while cancer slope factors (CSFs) were used to evaluate carcinogenic action levels.

Potential exposure pathways and receptors used to determine action levels are site-specific and should consider the current and future land use of a site. The following exposure scenarios were used in the determination of action levels for OU No. 2:

- Inhalation of particulates
- Incidental ingestion of soil
- Dermal contact with soil
- Ingestion of groundwater

Consistent with USEPA guidance, noncarcinogenic health effects were estimated using the concept of an average annual exposure. The action level incorporated the exposure time and/or frequency that represented the number of hours per day and the number of days per year that exposure occurs. This is used with a term known as the averaging time, which converts the daily exposure to an annual exposure. Carcinogenic health effects were calculated as an incremental lifetime cancer risk, and therefore represented the exposure duration (years) over the course of a potentially exposed individual's lifetime (70 years).

The estimation methods and models used in this section were consistent with current USEPA risk assessment guidance (USEPA, 1989a) (USEPA, 1991a). Exposure estimates associated with each exposure route are presented below. For the future residential land use action levels (i.e., soil ingestion, dermal contact with soil, and particulate inhalation), the carcinogenic action level considered 6 years as a child (weighing 15 kilogram [kg] on average) and 24 years as an adult (weighing 70 kg on average), for a total exposure of 30 years (the 90th percentile at one residence). Children are much more likely to come into contact with soil than

adults, and at a significantly higher contact rate. The following sections present the equations and inputs used in the estimation of action levels developed for OU No. 2.

Inhalation of Particulates

The action levels for exposure to fugitive dust (i.e., inhalation of particulates) were estimated for base personnel employed at the base and involved in maintenance activities. In addition, future residents could be exposed at their homes to fugitive dust emissions from the site. An emission model (Cowherd et al., 1985) was used to estimate the concentrations of respirable particulates in the air based on wind speed, vegetative cover, size of source area, etc. An average source area of 108,697 square centimeters (cm²) was used in the calculation of the particulate emission factor.

Based on this information, chemical-specific action levels were then estimated using the following expression (USEPA, December 1989):

$$C_s = \frac{TR \text{ or } THI * BW * AT_c \text{ or } AT_{nc} * DY}{CSF \text{ or } 1/RfD * EF * ED * ET * IR * 1/PEF * ABS}$$

Where:

- Cs = contaminant concentration in soil (mg/kg)
- TR = total lifetime risk
- THI = total hazard index
- BW = adult body weight (kg)
- AT_c = averaging time for carcinogens (yr)
- AT_{nc} = averaging time for noncarcinogens (yr)
- DY = days per year (day/year)
- CSF = cancer slope factor (mg/kg-day)⁻¹
- RfD = reference dose (mg/kg-day)
- EF = exposure frequency (day/yr)
- ED = exposure duration (yr)
- ET = exposure time (hour/day)
- IR = inhalation rate (m³/hour)
- PEF = particulate emission factor (Cowherd, 1985)
- ABS = percent absorbed in the lungs

The inhalation rate (IR) is specified as 20 m³/day for adults (0.83 m³/hour) and 10 m³/day for children (0.43 m³/hour). A higher inhalation rate of 30 m³/day (1.25 m³/hour) was used for adults involved in maintenance or construction activities. Absorption in the lungs was conservatively assumed to be 100 percent. The following exposure times were used:

Adult residents	=	16 hours/day
Child residents	=	24 hours/day
Base personnel	=	8 hours/day

Exposure frequencies were specified as 250 days/year for 25 years for base personnel working at the site, and 350 days/year for residents (USEPA, March 25, 1991). Exposure duration for residents was assumed to be 6 years for children and 30 years for adult residents. Thirty years is the 90th percentile for time spent in one residence (USEPA, December, 1989). The body weight for adults was assumed to be 70 kg, and for children a 15 kg body weight was used.

Table 2-5 presents a summary of the input parameters used to estimate the particulate emission action levels.

Incidental Ingestion of Soil

Individuals may be exposed to chemicals of potential concern in soil by incidental ingestion. Action levels for this route are estimated as follows (USEPA, December 1989):

$$C_s = \frac{TR \text{ or } THI * BW * AT_c \text{ or } AT_{nc} * DY}{CSF \text{ or } 1/RfD * EF * ED * IR * CF * Fi}$$

Where:

C _s	=	contaminant concentration in soil (mg/kg)
TR	=	total lifetime risk
THI	=	total hazard index
BW	=	adult body weight (kg)
AT _c	=	averaging time for carcinogens (yr)
AT _{nc}	=	averaging time for noncarcinogens (yr)
DY	=	days per year (day/year)
CSF	=	cancer slope factor (mg/kg-day) ⁻¹
RfD	=	reference dose (mg/kg-day)
EF	=	exposure frequency (day/yr)

TABLE 2-5

**INHALATION OF PARTICULATES
ACTION LEVEL PARAMETER
FEASIBILITY STUDY CTO-0133
MCB CAMP LEJEUNE, NORTH CAROLINA**

Inhalation of Particulates Input Parameters			
Input Parameter	Description	Value	Rationale
C _s	Exposure Concentration	Calculated	USEPA, December 1989
TR	Total Lifetime Risk	1.0E-4	USEPA, April 1991
THI	Total Hazard Index	1.0	USEPA, April 1991
BW	Body Weight	Child 15 kg Adult 70 kg	USEPA, December 1989
AT _c	Averaging Time Carcinogen	All 70 yr	USEPA, December 1989
AT _{nc}	Averaging Time Noncarcinogen	Child 6 yr Adult 30 yr Base Employee 25 yr	USEPA, December 1989
DY	Days Per Year	365 day/yr	USEPA, December 1989
CSF	Carcinogenic Slope Factor	Chemical Specific	IRIS, HEAST, USEPA
RfD	Reference Dose	Chemical Specific	IRIS, HEAST, USEPA
EF	Exposure Frequency	Resident 350 days/yr Base Employee 250 days/yr	USEPA, December 1989
ED	Exposure Duration	Child 6 yr Adult 30 yr Base Employee 25 yr	USEPA, March 1991
ET	Exposure Time	Child 24 hr/day Adult 16 hr/day Base Employee 8 hr/day	Professional Judgment
IR	Inhalation Rate	Children 0.43 m ³ /hr Adults 0.83 m ³ /hr Base Employee 1.25 m ³ /hr	USEPA, December 1989
PEF	Particulate Emission Factor	5.0E ⁸ m ³ /kg	USEPA, December 1989 Cowherd, 1985
ABS	Absorption into Lungs	100%	Conservative Professional Judgment

- ED = exposure duration (yr)
- IR = ingestion rate (mg/day)
- CF = conversion factor (10⁻⁶ kg/mg)
- Fi = fraction ingested from source (percent)

Exposure frequencies (EFs) were specified as 250 days/year for base personnel and 350 days/year for residents (USEPA, March 25, 1991). Exposure durations (EDs) for residents was assumed to be 6 years for children and 30 years for adult residents; whereas the ED assumed for base personnel was 25 years. Thirty years is the 90th percentile for time spent in one residence (USEPA, December, 1989). The body weight for adults was assumed to be 70 kg, and for children, 15 kg. For a conservative approach, it was assumed that 100 percent of the soil from the source was contaminated (Fi).

Table 2-6 presents the input parameters used to estimate the soil ingestion action levels.

Dermal Contact with Soil

Physical contact with contaminated soils can result in the dermal absorption of chemicals. Action levels through this route are estimated as follows (USEPA, December 1989):

$$C_s = \frac{TR \text{ or } THI * BW * AT_c \text{ or } AT_{nc} * DY}{CSF \text{ or } 1/RfD * SA * AF * ABS * EF * ED * CF}$$

Where:

- Cs = contaminant concentration in soil (mg/kg)
- TR = total lifetime risk
- THI = total hazard index
- BW = adult body weight (kg)
- ATc = averaging time carcinogens (yr)
- ATnc = averaging time noncarcinogens (yr)
- DY = days per year (day/year)
- CSF = cancer slope factor (mg/kg-day)⁻¹
- RfD = reference dose (mg/kg-day)
- SA = surface area of skin available for contact (cm²)
- AF = soil to skin adherence factor (mg/cm²)

TABLE 2-6
INGESTION OF SURFACE SOIL
ACTION LEVEL PARAMETER
FEASIBILITY STUDY CTO-0133
MCB CAMP LEJEUNE, NORTH CAROLINA

Incidental Ingestion of Surface Soil Input Parameters			
Input Parameter	Description	Value	Rationale
C _s	Exposure Concentration	Calculated	USEPA, December 1989
TR	Total Lifetime Risk	1.0E-4	USEPA, April 1991
THI	Total Hazard Index	1.0	USEPA, April 1991
BW	Body Weight	Child 15 kg Adult 70 kg	USEPA, December 1989
AT _c	Averaging Time Carcinogen	All 70 yr	USEPA, December 1989
AT _{nc}	Averaging Time Noncarcinogen	Child 6 yr Adult 30 yr Base Employee 25 yr	USEPA, December 1989
DY	Days Per Year	365 day/yr	USEPA, December 1989
CSF	Carcinogenic Slope Factor	Chemical Specific	IRIS, HEAST, USEPA
RfD	Reference Dose	Chemical Specific	IRIS, HEAST, USEPA
EF	Exposure Frequency	Child 350 day/yr Adult 350 day/yr Base Employee 250 day/yr	USEPA, December 1989
ED	Exposure Duration	Child 6 yr Adult 30 yr Base Employee 25 yr	USEPA, March 1991
IR	Ingestion Rate	Child 200 mg/day Adult 100 mg/day Base Employee 100 mg/day	USEPA, December 1989 Professional Judgment - nonconstruction
CF	Conversion Factor	1.0E-6 kg/mg	USEPA, December 1989
F _i	Fraction Ingested from Contaminated Source	100%	Conservative Professional Judgment

- ABS = absorption factor
- EF = exposure frequency (day/year)
- ED = exposure duration (yr)
- CF = conversion factor (10⁻⁶ kg/mg)

Three action levels were developed for this route of exposure. The first action level assumes that adult base personnel will be exposed to surface soil during routine maintenance activities conducted at the site. The other action levels assumed that the area would be used for residential development at some specified time in the future. The approximate exposed skin area for an adult worker wearing a short-sleeved shirt, pants, and shoes and no gloves or hat was set at 4,300 cm² (USEPA, January 1992). For residents who are assumed to be outdoors in this hot climate wearing only shorts, short sleeve shirt, and shoes; the exposed skin area was limited to the head, hands, forearms and lower legs: 5,300 cm² for adults, and 1,800 cm² for children (USEPA, January 1992).

Table 2-7 summarizes the input parameters used to estimate the dermal contact with soil action levels.

Ingestion of Groundwater

Currently there are no receptors who are exposed to groundwater contamination in this area since groundwater is obtained from "noncontaminated" supply wells, pumped to water treatment plants, and distributed via a potable water system. However, it is assumed for the purposes of calculating action levels, that potable wells would pump groundwater from the site area for public consumption. Groundwater ingestion action levels can be characterized using the following equation:

$$C_s = \frac{TR \text{ or } THI * BW * AT_c \text{ or } AT_{nc} * DY}{CSF \text{ or } 1/RfD * EF * ED * IR}$$

Where:

- Cw = contaminant concentration in groundwater (mg/L)
- TR = total lifetime risk
- THI = total hazard index
- BW = adult body weight (kg)
- ATc = averaging time carcinogens (yr)

TABLE 2-7

**SURFACE SOIL - DERMAL CONTACT
ACTION LEVEL PARAMETERS
FEASIBILITY STUDY CTO-0133
MCB CAMP LEJEUNE, NORTH CAROLINA**

Dermal Contact with Surface Soil Input Parameters				
Input Parameter	Description	Value		Rationale
C _s	Exposure Concentration	Calculated		USEPA, December 1989
TR	Total Lifetime Risk	1.0E ⁻⁴		USEPA, April 1991
THI	Total Hazard Index	1.0		USEPA, April 1991
BW	Body Weight	Child Adult	15 kg 70 kg	USEPA, December 1989
AT _c	Averaging Time Carcinogen	All	70 yr	USEPA, December 1989
AT _{nc}	Averaging Time Noncarcinogen	Child Adult Base Employee	6 yr 30 yr 25 yr	USEPA, December 1989
DY	Days Per Year	365 days/yr		USEPA, December 1989
CSF	Carcinogenic Slope Factor	Chemical Specific		IRIS, HEAST, USEPA
RfD	Reference Dose	Chemical Specific		IRIS, HEAST, USEPA
SA	Exposed Surface Area of Skin Available for Contact	Child Adult Base Employee	1,800 cm ² 5,300 cm ² 4,300 cm ²	USEPA, January 1992
AF	Soil-to-Skin Adherence Factor	1.0 mg/cm ²		USEPA, Region IV, 1992
ABS	Absorption Factor (dimensionless)	Volatiles Semivolatiles/ Pesticides PCBs Metals	0.10 0.05 0.03 0.01	Accounts for desorption from soil and percutaneous absorption (Feldman and Malbach, 1970; USEPA, October 1984; Wester and Malbach, 1985)
EF	Exposure Frequency	Child Adult Base Employee	350 days/yr 350 days/yr 250 days/yr	USEPA, December 1989
ED	Exposure Duration	Child Adult Base Employee	6 yr 30 yr 25 yr	USEPA, March 1991

- ATnc = averaging time noncarcinogens (yr)
- DY = days per year (day/year)
- CSF = cancer slope factor (mg/kg-day)⁻¹
- RfD = reference dose (mg/kg-day)
- EF = exposure frequency (day/year)
- ED = exposure duration (yr)
- IR = ingestion rate (L/day)

Under the base personnel scenario, the following input parameters were used to determine the action levels: base personnel are assumed to ingest 2 liters of water per day, 250 days per year, over a 25 year working lifetime (USEPA, 1989a). Under the residential use scenario, the following input parameters were used to estimate action levels: adult residents are assumed to ingest 2 liters of water per day, over a 30 year exposure duration; and child residents are assumed to ingest 1 liter of water per day, 350 days per year for an exposure period of 6 years (USEPA, 1989a). Table 2-8 summarizes the input parameters used to estimate the groundwater ingestion action levels.

2.3.3.2 Soil/Water Partitioning

COCs detected in the site soil samples could act as a potential source of contamination to underlying groundwater. To evaluate this potential contaminant migration pathway, a soil/water partitioning approach was used. The Organic Leaching Model (OLM) was used to determine the potential leachate concentrations of COCs leaching from the affected soils. This approach is described below.

The OLM Approach (USEPA, 1986) was used to estimate the potential concentration of contaminants in the groundwater due to leaching from soil. The OLM is an empirical equation which was developed through application of modeling techniques. The maximum detected organic soil concentrations were used in this estimation to determine a maximum concentration in groundwater. Contaminant specific solubilities were obtained from literature. Leachate concentrations were estimated using the following equation:

$$C_1 = 0.00211 * (C_w)^{0.0678} * (S)^{0.373}$$

Where:

- C₁ = contaminant concentration in (leachate) groundwater (mg/L)
- C_w = contaminant concentration in (waste) soil (mg/kg)
- S = contaminant solubility (mg/L)

TABLE 2-8

**INGESTION OF GROUNDWATER
ACTION LEVEL PARAMETERS
FEASIBILITY STUDY CTO-0133
MCB CAMP LEJEUNE, NORTH CAROLINA**

Ingestion of Groundwater Input Parameters				
Input Parameter	Description	Value		Rationale
C _w	Exposure Concentration	Calculated		USEPA, December 1989
TR	Total Lifetime Risk	1.0E ⁻⁴		USEPA, April 1991
THI	Total Hazard Index	1.0		USEPA, April 1991
BW	Body Weight	Child Adult	15 kg 70 kg	USEPA, December 1989
AT _c	Averaging Time Carcinogen	All	70 yr	USEPA, December 1989
AT _{nc}	Averaging Time Noncarcinogen	Child Adult Base Employee	6 yr 30 yr 25 yr	USEPA, December 1989
DY	Days Per Year	365 days/yr		USEPA, December 1989
CSF	Carcinogenic Slope Factor	Chemical Specific		IRIS, HEAST, USEPA
RfD	Reference Dose	Chemical Specific		IRIS, HEAST, USEPA
EF	Exposure Frequency	Child Adult Base Employee	350 days/yr 350 days/yr 250 days/yr	USEPA, December 1989
ED	Exposure Duration	Child Adult Base Employee	6 yr 30 yr 25 yr	USEPA, March 1991
IR	Ingestion Rate	Child Adult	1 L/day 2 L/day	USEPA, December, 1989

These estimated concentrations will be compared to the Federal and State groundwater ARARs to determine if the contaminants in the soil could potentially produce a groundwater concern. Table 2-9 summarizes the input parameters used for this model.

The OLM Approach was also used to estimate soil action levels that are protective of groundwater. This approach is considered conservative because it does not account for the vertical dilution of a contaminant through the unsaturated zone. Using the State or Federal Groundwater ARARs as target concentrations, the following method was used to estimate the soil action levels:

$$C_s = \left[\frac{C_1}{0.00211 \times S^{0.373}} \right] 1.4749$$

Where:

- C_s = contaminant concentration in soil (mg/kg)
- C₁ = State or Federal groundwater criteria concentration (mg/l)
- S = contaminant solubility (mg/l)

These estimated concentrations were compared to the maximum soil concentrations to determine if the soil could potentially produce a groundwater concern.

2.3.3.3 Summary of Site-Specific Risk-Based Action Levels

Site-specific risk-based action levels were calculated from the risk evaluation assessment and from the OLM Approach. These action levels represent the risk-based action levels for the cleanup of a specific medium, and are used in the FS to identify areas of concern. COCs were chosen based on available toxicity data and frequency of detection and available ARARs. Action levels were generated for contaminants with available toxicity data. A summary of the action levels calculated for the four potential exposure scenarios is presented below. Separate action levels for base personnel, adult residents, and children have been calculated for each scenario. In addition, both carcinogenic and noncarcinogenic action levels have been calculated. Calculations are provided in Appendix B of this report.

TABLE 2-9

**CONTAMINANT MIGRATION FROM SOIL TO
GROUNDWATER ACTION LEVEL PARAMETERS
FEASIBILITY STUDY CTO-0133
MCB CAMP LEJEUNE, NORTH CAROLINA**

Input Parameter	Description	Value	Rationale
C ₁	Constituent Concentration in Leachate (mg/L)	Calculated	OLM - Model
K	Constant	0.00211	Federal Register Vol. 51, No. 145
C _w	Constituent Concentration in Waste (mg/kg)	Contaminant Specific	Obtained from Maximum Concentration Detected in Site Soils
S	Constituent Solubility (mg/L)	Contaminant Specific	USEPA Aquatic Fate Process Data for Organic Priority Pollutants, 1982

Inhalation of Particulates

In order to estimate action level concentrations with respect to inhalation of particulates, frequently detected soil contaminants with available toxicity data, were assessed based on specific inputs. In order to assess the entire operable unit, an average area was used in the estimation of the site-specific particulate emission factor.

Contaminants of concern were chosen based on the frequency of detection in the surface soil and available toxicity data. The action levels calculated to prevent a cancer risk of $1.0E^{-4}$ are presented in Table 2-10. In addition, the action levels estimated not to exceed a HI of unity (1) for noncarcinogens are presented in Table 2-11.

Incidental Ingestion of Soil

Surface soil ingestion action levels were estimated for chemicals frequently detected in the surface soil. The inputs for the estimation were specific to the population of concern (i.e., base personnel, adult resident, and child resident). The action levels estimated to prevent a cancer risk of $1.0E^{-4}$ and a HI which exceeds unity are presented in Tables 2-12 and 2-13, respectively. Note that the "base personnel" action levels represents current and probable future risks since the area would most likely be utilized in the same manner that it is today. The action levels derived for "adult resident" and "child resident" represent a scenario that this area of the base would be used for residential housing. There are no current plans to use this area of the base for housing.

Dermal Contact with Soil

Action levels for exposure via dermal contact with surface soil were estimated for existing and future populations (i.e., base personnel, adult residents, and child residents). Chemicals of concerns were selected based on frequency of detection in the surface soil and available toxicity data. Action levels for the carcinogenic and noncarcinogenic chemicals are presented in Tables 2-14 and 2-15, respectively.

Ingestion of Groundwater

The groundwater ingestion action levels were estimated for the groundwater within the entire operable unit. Currently, there are no known receptors who ingest the groundwater. Base

TABLE 2-10**PARTICULATE INHALATION CARCINOGENIC ACTION LEVELS
FEASIBILITY STUDY CTO-0133
MCB CAMP LEJEUNE, NORTH CAROLINA**

Contaminant	Carcinogenic Risk		
	Base Personnel	Adult Resident	Child Resident
4,4'-DDT	4,200,000,000	1,900,000,000	2,600,000,000
Dieldrin	89,000,000	40,000,000	55,000,000
1,2-Dichloroethene	16,000,000,000	7,000,000,000	9,700,000,000
Benzene	49,000,000,000	22,000,000,000	3,000,000,000
1,1,2,2-Tetrachloroethane	7,200,000,000	3,200,000,000	4,400,000,000
Arsenic	29,000,000	13,000,000	18,000,000
Beryllium	170,000,000	76,000,000	110,000,000
Cadmium	23,000,000	100,000,000	140,000,000
Chromium	34,000,000	15,000,000	210,000,000

Notes: Action level concentrations expressed as $\mu\text{g}/\text{kg}$

TABLE 2-11

**PARTICULATE INHALATION NONCARCINOGENIC ACTION LEVELS
FEASIBILITY STUDY CTO-0133
MCB CAMP LEJEUNE, NORTH CAROLINA**

Contaminant	Noncarcinogenic Risk		
	Base Personnel	Adult Resident	Child Resident
1,4-Dichlorobenzene	4,100,000,000,000	2,200,000,000,000	610,000,000,000
Manganese	2,000,000,000	1,110,000,000	300,000,000

Notes: Action level concentrations expressed as $\mu\text{g}/\text{kg}$

TABLE 2-12

**SURFACE SOIL INGESTION CARCINOGENIC ACTION LEVELS
FEASIBILITY STUDY CTO-0133
MCB CAMP LEJEUNE, NORTH CAROLINA**

Contaminant	Carcinogenic Risk		
	Base Personnel	Adult Resident	Child Resident
4,4'-DDD	1,200,000	710,000	380,000
4,4'-DDE	840,000	500,000	270,000
4,4'-DDT	840,000	500,000	270,000
PCB-1260	37,000	22,000	12,000
Arsenic	170,000	97,000	52,000
Beryllium	67,000	39,000	21,000
1,4-Dichlorobenzene	12,000,000	7,100,000	3,800,000
Benzene	9,900,000	5,900,000	3,100,000
1,1,2,2-Tetrachloroethane	1,400,000	850,000	460,000
Benzo(a)anthracene	39,000	23,000	12,500
Benzo(b)fluoranthene	39,000	23,000	12,500
Benzo(k)fluoranthene	39,000	23,000	12,500
Benzo(a)pyrene	39,000	23,000	12,500
Chrysene	39,000	23,000	12,500
Indeno (1, 2, 3-cd) pyrene	39,000	23,000	12,500

Notes: Action level concentrations expressed as µg/kg

TABLE 2-13

**SURFACE SOIL INGESTION NONCARCINOGENIC ACTION LEVELS
FEASIBILITY STUDY CTO-0133
MCB CAMP LEJEUNE, NORTH CAROLINA**

Contaminant	Noncarcinogenic Risk		
	Base Personnel	Adult Resident	Child Resident
4,4'-DDT	510,000	360,000	39,000
1,1,1-Trichloroethane	92,000,000	65,000,000	7,000,000
1,2-Dichloroethene	10,000,000	7,300,000	780,000
Anthracene	300,000,000	219,000,000	23,000,000
Fluoranthene	40,000,000	29,200,000	3,100,000
Pyrene	30,000,000	21,900,000	2,300,000
Acenaphthene	61,000,000	43,800,000	4,700,000
Arsenic	310,000	220,000	23,000
Barium	72,000,000	51,000,000	5,500,000
Beryllium	5,100,000	370,000	390,000
Cadmium	5,100,000	370,000	39,000
Chromium	5,100,000	3,700,000	390,000
Manganese	5,100,000	3,700,000	390,000
Nickel	20,000,000	15,000,000	1,600,000
Zinc	310,000,000	220,000,000	23,000,000

Notes: Action level concentrations expressed as µg/kg

TABLE 2-14

**SURFACE SOIL DERMAL CONTACT
CARCINOGENIC ACTION LEVELS
FEASIBILITY STUDY CTO-0133
MCB CAMP LEJEUNE, NORTH CAROLINA**

Contaminant	Carcinogenic Risk		
	Base Personnel	Adult Resident	Child Resident
1,4-Dichlorobenzene	2,700,000	1,300,000	4,200,000
Benzene	2,300,000	1,100,000	3,500,000
1,1,2,2-Tetrachloroethane	3,300,000	160,000	510,000
4,4'-DDD	550,000	270,000	840,000
4,4'-DDE	390,000	190,000	60,000
4,4'-DDT	390,000	190,000	60,000
PCB-1260	29,000	14,000	44,000
Benzo(a)anthracene	30,000	15,000	46,000
Benzo(b)fluoranthene	30,000	15,000	46,000
Benzo(k)fluoranthene	30,000	15,000	46,000
Benzo(a)pyrene	30,000	15,000	46,000
Chrysene	30,000	15,000	46,000
Indeno (1, 2, 3-cd) pyrene	30,000	15,000	46,000
Arsenic	38,000	180,000	580,000
Beryllium	150,000	74,000	240,000

Notes: Action level concentrations expressed as µg/kg

TABLE 2-15

**SURFACE SOIL DERMAL CONTACT
NONCARCINOGENIC ACTION LEVELS
FEASIBILITY STUDY CTO-0133
MCB CAMP LEJEUNE, NORTH CAROLINA**

Contaminant	Noncarcinogenic Risk		
	Base Personnel	Adult Resident	Child Resident
4,4'-DDT	240,000	140,000	87,000
1,1,1-Trichloroethane	21,000,000	12,000,000	7,800,000
1,2-Dichloroethene	2,300,000	1,300,000	860,000
Anthracene	240,000,000	140,000,000	87,000,000
Fluoranthene	32,000,000	18,000,000	12,000,000
Pyrene	24,000,000	14,000,000	8,700,000
Acenaphthene	48,000,000	28,000,000	17,000,000
Arsenic	710,000	410,000	260,000
Barium	170,000,000	96,000,000	6,000,000
Beryllium	12,000,000	6,900,000	4,300,000
Cadmium	1,200,000	690,000	430,000
Chromium	12,000,000	6,900,000	4,300,000
Manganese	12,000,000	6,900,000	4,300,000
Nickel	4,800,000	28,000,000	17,000,000
Zinc	710,000,000	410,000,000	260,000,000

Notes: Action level concentrations expressed as µg/kg

personnel receive potable water via a base water distribution. However, a hypothetical future ingestion action level was estimated for the COCs. In order to estimate conservative action levels for subpopulations (i.e., base personnel, adult resident, and child resident), specific input variables were developed for each subpopulation. Tables 2-16 and 2-17 present the action levels calculated for the carcinogenic and noncarcinogenic COCs in the groundwater, respectively.

OLM Approach

The soil/water partitioning approach was used to estimate the concentration of contaminants in the aqueous phase due to leaching or partitioning from the solid phase. Model inputs, solubility, and partitioning coefficients limited the estimating to organic contaminants. The concentrations estimated from this model are discussed below.

Estimating exposure concentrations in groundwater using models such as the OLM Approach can be very complex because of the many physical and chemical processes that may affect transport and transformation in groundwater. Among the important mechanisms that should be considered when estimating exposure concentrations in groundwater are: leaching from the surface, advection, dispersion, sorption, and transformation.

The OLM, used to estimate a groundwater concentration, is a conservative model that estimates the amount of organic contaminants that will leach into the groundwater from a source (soil contamination). It does not account for physical or chemical processes that may impact the migration of contamination from soil to water.

In order to calculate a conservative concentration, maximum concentrations of VOCs, and pesticide/PCB contaminants detected in the soil at OU No. 2 were used. The groundwater concentrations estimated using the OLM are presented in Table 2-18. For chemicals where Federal and State groundwater ARARs are not established, the estimated concentrations can be compared to toxicity values to assist in determining long-range cleanup goals for surface and subsurface soils.

As stated in Section 2.3.3.2, the OLM Approach was also used to estimate soil action levels that are protective of groundwater. The soil action levels that were calculated are presented on Table 2-18. Based on a review of this table, it appears that benzene, trichloroethene,

TABLE 2-16

**GROUNDWATER INGESTION ACTION LEVELS BASED ON
CARCINOGENIC RISK
FEASIBILITY STUDY CTO-0133
MCB CAMP LEJEUNE, NORTH CAROLINA**

Contaminant of Concern	Action Levels Based on Carcinogenic Risk		
	Base Personnel	Adult Resident	Child Resident
Bromodichloromethane	231	137	294
1,2-Dichloroethane	157	94	201
1,1-Dichloroethene	24	14	30
1,1,2,2-Tetrachloroethane	72	43	91
1,1,2-Trichloroethane	251	149	320
Vinyl Chloride	8.0	4.0	10
Trichloroethene	1,301	774	1,659
Tetrachloroethene	275	164	351
Arsenic	8.0	5.0	10
Beryllium	3.0	2.0	4.0

Notes: Action level concentrations expressed as µg/L

TABLE 2-17

**GROUNDWATER INGESTION ACTION LEVELS
BASED ON NONCARCINOGENIC RISK
FEASIBILITY STUDY CTO-0133
MCB CAMP LEJEUNE, NORTH CAROLINA**

Contaminant of Concern	Action Levels Based on Noncarcinogenic Risk		
	Base Personnel	Adult Resident	Child Resident
Bromodichloromethane	1,022	730	313
Chlorobenzene	1,022	730	313
1,1-Dichloroethene	460	328	141
Tetrachloroethene	511	365	156
1,1,2-Trichloroethane	204	146	63
Ethyl benzene	5,110	3,650	1,564
Total Xylenes	102,200	73,000	31,286
Arsenic	15	11	5
Barium	3,577	2,555	1,095
Beryllium	256	183	78
Chromium	256	183	78
Manganese	256	183	78
Nickel	1,022	730	313
Zinc	15,330	10,950	4,693

Notes: Action level concentrations expressed as µg/L.

TABLE 2-18

**ESTIMATED GROUNDWATER CONCENTRATIONS AND SOIL
ACTION LEVELS DETERMINED FROM THE OLM COMPARED TO
FEDERAL AND STATE CRITERIA
FEASIBILITY STUDY CTO-0133
MCB CAMP LEJEUNE, NORTH CAROLINA**

Contaminant of Concern	Maximum Concentration in Soil ($\mu\text{g}/\text{kg}$)	Soil Action Level ($\mu\text{g}/\text{kg}$)	Estimated Concentration in Groundwater ($\mu\text{g}/\text{L}$)	Federal MCL ($\mu\text{g}/\text{L}$)	NCWQS ($\mu\text{g}/\text{L}$)
1,4-Dichlorobenzene	160	--	3.1	75	1.8
Benzene	850	5.4	31	5	1.0
1,2-Dichloroethene	1,500	5,184	30	70	NE
Trichloroethene	4,600	32.2	81	5	2.8
1,1,2,2-Tetrachloroethane	55,000	--	625	NE	NE
1,1,1-Trichloroethane	42	22,000	3.0	200	200
Tetrachloroethene	7,000	10.7	57	5	0.7
Chloromethane	490	--	34	NE	NE
Bromomethane	1,300	--	32	NE	NE
4,4'-DDD	12,000	--	5	NE	NE
4,4'-DDE	4,200	--	2	NE	NE
4,4'-DDT	6,400	--	1	NE	NE
Dieldrin	280	--	0.5	NE	NE
Gamma Chlordane	160	4,512	0.2	2	NE
PCB 1260	42,000	3,096	3	0.5	NE

Notes: $\mu\text{g}/\text{kg}$ = microgram per kilogram
 $\mu\text{g}/\text{L}$ = microgram per liter
MCL = Federal Maximum Contaminant Level
NCWQS = North Carolina Water Quality Standards
NE = Not Established

 = The contaminant of concern concentration is estimated to exceed groundwater criteria and/or the calculated soil action level.

tetrachloroethene, and PCB-1260 concentrations detected in soil may not be protective of human health and the environment.

2.3.3.4 Comparison of Risk-Based Action Levels to Maximum Contaminant Concentrations in Soils

Generally, risk-based action levels are not required for any contaminants in a medium with a cumulative cancer risk of less than $1.0E-6$, where an HI is less than or equal to 1.0, or where the action levels are clearly defined by ARARs. However, there may be cases where a medium or contaminant appears to meet the protectiveness criterion but contributes to the risk of another medium. In some cases, contamination may be unevenly distributed across the site resulting in hot spots (areas of high contamination relative to other areas of the site). Therefore, if the hot spot is located in an area which is visited or used more frequently, exposure to the spot should be assessed separately.

In order to decrease uncertainties in the estimation of the reasonable maximum exposure (RME), which is the maximum exposure that is reasonably expected to occur at the site, the maximum concentration of a contaminant in a media can be compared to the estimated action level. Assessment of hot spot contaminants is performed as a conservative approach in place of using the concentration term (i.e., the 95th percent upper confidence limit) which is used in estimating the RME. This value is usually compared to the estimated risk-based action level because in most situations, assuming long-term contact with the maximum contaminant concentration is not reasonable.

Conclusions of the human health RA for cumulative current and future baseline cancer risks for soil are within the USEPA's acceptable risk range of $1.0E-6$ to $1.0E-4$. Due to specific "hot spots" identified in the soils, a comparison between the risk-based action levels previously estimated to the maximum concentrations of soil COCs has been conducted. Risk-based action levels for contaminants which may not have been COCs in the baseline RA, due to prevalence, have been estimated for inhalation of particulates, incidental ingestion of soil, and dermal contact with soil.

These risk-based action levels are compared to maximum (hot spot) contaminant concentration in Table 2-19 (inhalation of particulates), Table 2-20 (incidental ingestion), and Table 2-21 (dermal contact). Concentrations exceeding an action level are identified on the tables with a different type font. As shown on the tables, the maximum concentration of

TABLE 2-19

COMPARISON OF INHALATION RISK-BASED ACTION LEVELS TO MAXIMUM CONTAMINANT PER GRID AREA
 FEASIBILITY STUDY CTO-0133
 MCB CAMP LEJEUNE, NORTH CAROLINA

Contaminant	Action Levels			Maximum Contaminant Concentration per Grid Area		
	Base Personnel	Adult Resident	Child Resident	Lot 201	Lot 203	Wooded Areas/ Ravine
Carcinogens						
4,4'-DDT	4,200,000,000	1,900,000,000	2,600,000,000	1,200,000	1,500	6,400
Dieldrin	89,000,000	40,000,000	55,000,000	46	270	87
1,2-Dichloroethene	16,000,000,000	7,000,000,000	9,700,000,000	ND	ND	1,500
Benzene	49,000,000,000	22,000,000,000	3,000,000,000	ND	ND	850
1,1,2,2-Tetrachloroethane	7,200,000,000	3,200,000,000	4,400,000,000	ND	ND	55,000
Tetrachloroethene	70,000,000,000	320,000,000,000	440,000,000,000	ND	ND	7,000
Arsenic	29,000,000	13,000,000	18,000,000	9,700	4,900	26,300
Beryllium	170,000,000	76,000,000	110,000,000	220	210	2,200
Cadmium	23,000,000	100,000,000	140,000,000	1,500	9,300	51,900
Chromium	34,000,000	15,000,000	210,000,000	21,600	25,200	54,600
Noncarcinogens						
1,4-Dichlorobenzene	4,100,000,000,000	2,200,000,000,000	610,000,000,000	38	160	ND
Manganese	2,000,000,000	1,100,000,000	300,000,000	204,000	182,000	700,000

Notes: Action level concentrations expressed as µg/kg.
 ND = Not detected

TABLE 2-20

COMPARISON OF SOIL INGESTION RISK-BASED ACTION LEVELS TO
 MAXIMUM CONTAMINANT CONCENTRATIONS PER GRID AREA
 FEASIBILITY STUDY CTO-0133
 MCB CAMP LEJEUNE, NORTH CAROLINA

Contaminant	Action Levels			Maximum Contaminant Concentration per Grid Area		
	Base Personnel	Adult Resident	Child Resident	Lot 201	Lot 203	Wooded Areas
Carcinogens						
4,4'-DDD	1,200,000	710,000	380,000	180,000	180	12,000
4,4'-DDE	840,000	500,000	270,000	17,000	2,100	4,200
<i>4,4'-DDT</i>	<i>840,000</i>	<i>500,000</i>	<i>270,000</i>	<i>1,200,000</i>	1,500	6,400
<i>PCB-1260</i>	<i>37,000</i>	<i>22,000</i>	<i>12,000</i>	36	<i>42,000</i>	<i>26,000</i>
1,4-Dichlorobenzene	12,000,000	7,100,000	3,800,000	38	160	ND
Benzene	9,900,000	5,900,000	3,100,000	ND	ND	850
1,1,2,2-Tetrachloroethane	1,400,000	850,000	460,000	ND	ND	55,000
Tetrachloroethene	5,500,000	3,200,000	1,700,000	ND	ND	7,000
Benzo(a)anthracene	39,000	23,000	12,500	47	1,600	2,200
Benzo(b)fluoranthene	39,000	23,000	12,500	160	2,700	2,200
Benzo(k)fluoranthene	39,000	23,000	12,500	46	1,100	490
Benzo(a)pyrene	39,000	23,000	12,500	78	1,800	1,500
Chrysene	39,000	23,000	12,500	88	1,300	1,600
Indeno(1, 2, 3-cd)pyrene	39,000	23,000	12,500	ND	1,000	1,300
Arsenic	170,000	97,000	52,000	9,700	4,900	26,300
Beryllium	67,000	39,000	21,000	220	210	2,200

Notes: Action level concentrations expressed as µg/kg.

ND = Not detected

Italicized text indicates concentrations which exceed an action level

TABLE 2-20 (Continued)

COMPARISON OF SOIL INGESTION RISK-BASED ACTION LEVELS TO
 MAXIMUM CONTAMINANT CONCENTRATIONS PER GRID AREA
 FEASIBILITY STUDY CTO-0133
 MCB CAMP LEJEUNE, NORTH CAROLINA

Contaminant	Action Levels			Maximum Contaminant Concentration per Grid Area		
	Base Personnel	Adult Resident	Child Resident	Lot 201	Lot 203	Wooded Areas
Noncarcinogens						
1,1,1-Trichloroethane	92,000,000	65,000,000	7,000,000	42	15	ND
1,2-Dichloroethene	10,000,000	7,300,000	780,000	ND	ND	1,500
Tetrachloroethene	10,000,000	7,300,000	780,000	ND	ND	7,000
Anthracene	300,000,000	219,000,000	23,000,000	ND	440	260
Fluoranthene	40,000,000	29,200,000	3,100,000	94	2,300	2,000
Pyrene	30,000,000	21,900,000	2,300,000	99	2,800	2,700
Acenaphthene	61,000,000	43,800,000	4,700,000	ND	9,500	370
Barium	72,000,000	51,000,000	5,500,000	16,500	47,800	1,410,000
<i>Cadmium</i>	510,000	370,000	<i>39,000</i>	1,500	9,300	<i>51,900</i>
Chromium	5,100,000	3,700,000	390,000	21,600	25,200	54,600
<i>Manganese</i>	5,100,000	3,700,000	<i>390,000</i>	20,400	182,000	<i>700,000</i>
<i>Arsenic</i>	310,000	220,000	<i>23,000</i>	9,700	4,900	<i>26,300</i>
Beryllium	5,100,000	370,000	390,000	220	210	2,200
Nickel	20,000,000	15,000,000	1,600,000	6,400	13,200	79,400
Zinc	310,000,000	220,000,000	23,000,000	135,000	604,000	16,600,000

Notes: Action level concentrations expressed as µg/kg.
 ND = Not detected
 Italicized text indicates concentrations which exceed an action level.

TABLE 2-21

**COMPARISON OF DERMAL CONTACT RISK-BASED ACTION LEVELS TO
MAXIMUM CONTAMINANT CONCENTRATIONS PER GRID AREA
FEASIBILITY STUDY CTO-0133
MCB CAMP LEJEUNE, NORTH CAROLINA**

Contaminant	Action Levels			Maximum Contaminant Concentration per Grid Area		
	Base Personnel	Adult Resident	Child Resident	Lot 201	Lot 203	Wooded Areas
Carcinogens						
4,4'-DDD	550,000	270,000	840,000	180,000	180	12,000
4,4'-DDE	390,000	190,000	60,000	17,000	2,100	4,200
<i>4,4'-DDT</i>	<i>390,000</i>	<i>190,000</i>	<i>60,000</i>	<i>1,200,000</i>	1,500	6,400
<i>PCB-1260</i>	29,000	<i>14,000</i>	44,000	36	<i>42,000</i>	<i>26,000</i>
1,4-Dichlorobenzene	2,700,000	1,300,000	4,200,000	38	160	ND
Benzene	2,300,000	1,100,000	3,500,000	ND	ND	850
1,1,2,2-Tetrachloroethane	3,300,000	160,000	510,000	ND	ND	55,000
Tetrachloroethene	1,200,000	610,000	1,900,000	ND	ND	7,000
Benzo(a)anthracene	30,000	15,000	46,000	47	1,600	2,200
Benzo(b)fluoranthene	30,000	15,000	46,000	160	2,700	2,200
Benzo(k)fluoranthene	30,000	15,000	46,000	46	1,100	490
Benzo(a)pyrene	30,000	15,000	46,000	78	1,800	1,500
Chrysene	30,000	15,000	46,000	88	1,300	1,600
Indeno (1, 2, 3-cd) Pyrene	30,000	15,000	46,000	ND	1,000	1,300
Arsenic	38,000	180,000	580,000	9,700	4,900	26,300
Beryllium	150,000	74,000	240,000	220	210	2,200

Notes: Action level concentrations expressed as µg/kg.

ND = Not detected

Italicized text indicates concentrations which exceed an action level.

TABLE 2-21 (Continued)

COMPARISON OF DERMAL CONTACT RISK-BASED ACTION LEVELS TO
 MAXIMUM CONTAMINANT CONCENTRATIONS PER GRID AREA
 FEASIBILITY STUDY CTO-0133
 MCB CAMP LEJEUNE, NORTH CAROLINA

Contaminant	Action Levels			Maximum Contaminant Concentration per Grid Area		
	Base Personnel	Adult Resident	Child Resident	Lot 201	Lot 203	Wooded Areas
Noncarcinogens						
<i>4,4'-DDT</i>	<i>240,000</i>	<i>140,000</i>	<i>87,000</i>	<i>1,200,000</i>	1,500	6,400
1,1,1-Trichloroethane	21,000,000	12,000,000	7,800,000	42	15	ND
1,2-Dichloroethene	2,300,000	1,300,000	860,000	ND	ND	1,500
Tetrachloroethene	2,300,000	1,300,000	860,000	ND	ND	7,000
Anthracene	240,000,000	140,000,000	87,000,000	ND	440	260
Fluoranthene	32,000,000	18,000,000	12,000,000	94	2,300	2,000
Pyrene	24,000,000	14,000,000	8,700,000	99	2,800	2,700
Acenaphthene	48,000,000	28,000,000	17,000,000	ND	9,500	370
Barium	170,000,000	96,000,000	6,000,000	16,500	47,800	1,410,000
Beryllium	12,000,000	6,900,000	4,300,000	220	210	2,200
Cadmium	1,200,000	690,000	430,000	1,500	9,300	51,900
Chromium	12,000,000	6,900,000	4,300,000	21,600	25,200	54,600
Manganese	12,000,000	6,900,000	4,300,000	20,400	182,000	700,000
Nickel	48,000,000	28,000,000	17,000,000	6,400	13,200	79,400
Arsenic	710,000	410,000	260,000	9,700	4,900	26,300
Zinc	710,000,000	410,000,000	260,000,000	135,000	604,000	16,600,000

Notes: Action level concentrations expressed as µg/kg.

ND = Not detected

Italicized text indicates concentrations which exceed an action level.

4,4'-DDT at Lot 201 exceeded the action levels for ingestion and dermal contact with soils for all potentially exposed receptors. Maximum concentrations of PCB-1260 detected at Lot 203 and the wooded areas exceeded the action levels estimated for ingestion of soil for all potential receptors and for dermal contact with the soil for potential adult residents. Maximum cadmium, manganese and arsenic concentrations detected at the wooded areas exceeded the action levels for ingestion of soil by a child resident under a future potential scenario.

Identification of remedial alternatives should not solely be placed on the estimation of risk-based action levels, especially in the event of the maximum hot spot contamination. Comparison of maximum contaminant concentration to risk-based action levels was performed to provide a upper-bound conservative estimation, and aid in the screening and identification of remedial alternatives. They are not to be used in making final remedial decisions.

2.3.3.5 Uncertainty Analysis

The uncertainties associated with calculating risk-based action levels are summarized below. The action level estimations presented in this section are quantitative in nature, and their results are highly dependent upon the accuracy of the input. The accuracy with which input values can be quantified is critical to the degree of confidence that the decision maker has in the action levels.

Most scientific computation involves a limited number of input variables, which are tied together by a scenario to provide a desired output. Some action level inputs are based on literature values rather than measured values. In such cases the degree of certainty may be expressed as whether the estimate was based on literature values or measured values, not on how well defined the distribution of the input was. Some action levels are based on estimated parameters; the qualitative statement that the action level was based on estimated inputs defines the certainty in a qualitative manner.

The toxicity factors, CSFs and RfDs, have uncertainties built into the assumptions used to calculate these values. Because the toxicity factors are determined from high doses administered to experimental animals and extrapolated to low doses to which humans may be exposed, uncertainties exist. Thus, toxicity factors could either overestimate or underestimate the potential effects on humans. However, because human data exists for very few chemicals, risks are based on these values.

In addition, the exposure assumption (e.g., 10 events per year, etc.) also have uncertainties associated with them.

2.3.4 Summary of Remediation Goals and COCs

The preliminary remediation goals associated with OU No. 2 are presented on Table 2-22. This list was based on a comparison of contaminant-specific ARARs and the site-specific risk based action levels identified throughout Section 2.0 of the FS. If a COC had an ARAR, the most limiting (or conservative) ARAR was selected as the remediation goal for that contaminant. If a COC did not have an ARAR, the most conservative risk-based action level was selected for the remediation goal. The basis for each of the remediation goals is also presented in Table 2-22.

In order to determine the critical set of COCs for OU No. 2, the contaminant concentrations detected in both media were compared to the preliminary remediation goals presented on Table 2-22. The contaminants which exceeded at least one of the remediation goals have been retained as COCs. The contaminants that did not exceed any of the preliminary remediation goals will no longer be considered as COCs with respect to this FS. Based on this comparison, the following COCs exceeded a remediation goal and will be retained as COCs for OU No. 2:

- | | |
|----------------------------|---------------------|
| ● <u>Groundwater</u> | ● <u>Soil</u> |
| - 1,2-Dichloroethane | - PCBs |
| - Trans-1,2-Dichloroethene | - Benzene |
| - Ethylbenzene | - Trichloroethene |
| - Tetrachloroethene | - Tetrachloroethene |
| - Trichloroethene | - 4,4'-DDT |
| - Vinyl Chloride | - Arsenic |
| - Arsenic | - Cadmium |
| - Barium | - Manganese |
| - Beryllium | |
| - Chromium | |
| - Lead | |
| - Manganese | |
| - Mercury | |
| - Vanadium | |

The final set of COCs and their associated remediation goals are presented on Table 2-23.

TABLE 2-22

PRELIMINARY REMEDIATION GOALS
FEASIBILITY STUDY CTO-0133
MCB CAMP LEJEUNE, NORTH CAROLINA

Medium	Contaminant of Concern	Remediation Goal	Unit	Basis of Goal	Corresponding Risk	
					Carcinogenic	Noncarcinogenic
Groundwater	Bromodichloromethane	100	µg/L	MCL	ICR = 1.0E-4	
	Chlorobenzene	300	µg/L	MCL		
	1,2-Dichloroethane	0.38	µg/L	NC WQS		
	1,1-Dichloroethene	7	µg/L	MCL		
	Trans-1,2-Dichloroethene	70	µg/L	NC WQS		
	Ethylbenzene	29	µg/L	NC WQS		
	1,1,2,2-Tetrachloroethane	43	µg/L	Risk-Ingestion		
	Tetrachloroethene	0.7	µg/L	NC WQS		
	1,1,1-Trichloroethane	200	µg/L	NC WQS		
	1,1,2-Trichloroethane	5	µg/L	MCL		
	Trichloroethene	2.8	µg/L	NC WQS		
	Vinyl Chloride	0.015	µg/L	NC WQS		
	Xylenes	400	µg/L	NC WQS		
	Phenol	6,000	µg/L	Health Advisory		
	Antimony	50	µg/L	MCL		
	Arsenic	50	µg/L	NC WQS		
	Barium	1,000	µg/L	NC WQS		
	Beryllium	4	µg/L	MCL		
	Chromium	50	µg/L	NC WQS		
	Copper	1,000	µg/L	NC WQS		
	Lead	15	µg/L	MCL		
	Manganese	50	µg/L	NC WQS		
	Mercury	1.1	µg/L	NC WQS		
	Nickel	100	µg/L	MCL		
	Vanadium	80	µg/L	Health Advisory		
	Zinc	5,000	µg/L	NC WQS		

TABLE 2-22 (Continued)

PRELIMINARY REMEDIATION GOALS
FEASIBILITY STUDY CTO-0133
MCB CAMP LEJEUNE, NORTH CAROLINA

Medium	Contaminant of Concern	Remediation Goal	Unit	Basis of Goal	Corresponding Risk	
					Carcinogenic	Noncarcinogenic
Soil	PCBs	10,000	µg/kg	TSCA nonrestricted access area		
	Benzene	5.4	µg/kg	Risk-Protection of Groundwater		
	Trichloroethene	32.2	µg/kg	Risk-Protection of Groundwater		
	Tetrachloroethene	10.5	µg/kg	Risk-Protection of Groundwater		
	1,2-Dichloroethene	780,000	µg/kg	Risk-Ingestion		HI = 1.0
	1,1,2,2-Tetrachloroethane	160,000	µg/kg	Risk-Dermal Contact	ICR = 1.0E-4	
	1,1,1-Trichloroethane	7,000,000	µg/kg	Risk-Ingestion		HI = 1.0
	1,4-Dichlorobenzene	1,300,000	µg/kg	Risk-Dermal Contact	ICR = 1.0E-4	
	4,4'-DDD	270,000	µg/kg	Risk-Dermal Contact	ICR = 1.0E-4	
	4,4'-DDE	60,000	µg/kg	Risk-Dermal Contact	ICR = 1.0E-4	
	4,4'-DDT	60,000	µg/kg	Risk-Dermal Contact	ICR = 1.0E-4	
	Dieldrin	40,000,000	µg/kg	Risk-Inhalation	ICR = 1.0E-4	
	Arsenic	23,000	µg/kg	Risk-Ingestion		HI = 1.0
	Barium	5,500,000	µg/kg	Risk-Ingestion		HI = 1.0
	Beryllium	21,000	µg/kg	Risk-Ingestion	ICR = 1.0E-4	
	Cadmium	39,000	µg/kg	Risk-Ingestion		HI = 1.0
	Chromium	390,000	µg/kg	Risk-Ingestion		HI = 1.0
	Manganese	390,000	µg/kg	Risk-Ingestion		HI = 1.0
Zinc	23,000,000	µg/kg	Risk-Ingestion		HI = 1.0	

TABLE 2-23

FINAL
 REMEDIATION GOALS FOR OU NO. 2
 FEASIBILITY STUDY CTO-0133
 MCB CAMP LEJEUNE, NORTH CAROLINA

Media	Contaminant of Concern	Preliminary Remediation Goal	Unit
Groundwater	1,2-Dichloroethane	0.38	µg/L
	Trans-1,2-Dichloroethene	70	µg/L
	Ethylbenzene	29	µg/L
	Tetrachloroethene	0.7	µg/L
	Trichloroethene	2.8	µg/L
	Vinyl Chloride	0.015	µg/L
	Arsenic	50	µg/L
	Barium	1,000	µg/L
	Beryllium	4	µg/L
	Chromium	50	µg/L
	Lead	15	µg/L
	Manganese	50	µg/L
	Mercury	1.1	µg/L
	Vanadium	80	µg/L
Soil	PCBs	10,000	µg/kg
	4,4'-DDT	60,000	µg/kg
	Benzene	5.4	µg/kg
	Trichloroethene	32.2	µg/kg
	Tetrachloroethene	10.5	µg/kg
	Arsenic	23,000	µg/kg
	Cadmium	39,000	µg/kg
	Manganese	390,000	µg/kg

2.3.5 Areas of Concern Requiring Remediation

The results of the RA and an evaluation of the COCs concentrations exceeding the developed remediation goals were used to determine the areas of concern at OU No. 2 requiring remediation. This determination is presented below.

As previously stated, based on the risk evaluation presented in the RI Report, groundwater was the only media at the operable unit which presented a calculated carcinogenic risk greater than $1.0E^{-4}$ and/or a noncarcinogenic HI > 1.0 . The calculated carcinogenic risks from the other media were generally $1.0E^{-5}$ or less. The HIs from the other media were significantly less than 1.0. In addition, based on a comparison of the detected concentrations of the COCs in the groundwater to the remediation goals, several goals were exceeded. The organic COCs were exceeded primarily in the monitoring wells located at Site 82. The inorganic COCs exceeding the remediation goals were detected in monitoring wells throughout the operable unit and at background (upgradient) locations. Based on wide spread inorganic contamination, the area of concern (AOC) requiring remediation (with respect to contaminated groundwater) will focus on the organic contamination.

Figure 2-1 shows the location of where the groundwater remediation goals were exceeded for organic compounds in both the shallow and deeper portions of the aquifers. The largest plumes appear to originate from Site 82. The plume from the deeper portion of the aquifer covers over 168 acres. The plume from the shallower portion of the aquifer covers approximately 43 acres. Figure 2-1 also identifies 4 small plumes located south and west of Lot 203. Tetrachloroethene (PCE) was the only COC detected in three of the wells at these areas which exceeded the remediation goals. These three wells included 6GW7, 6GW21, and 6GW22. The detected PCE concentrations were 1.1 $\mu\text{g/L}$ and 1.2 $\mu\text{g/L}$. The remediation goal for PCE is 0.7 $\mu\text{g/L}$. No other COCs were detected at either of these locations. Since the PCE concentrations slightly exceeded the preliminary remediation goal, these three areas will be considered as AOCs for the operable unit. At well 6GW16, chlorobenzene, 1,1,2,2-TCA, and PCE were detected at levels greater than the remediation goals in the second round sample. Therefore, the immediate area around 6GW16 will be considered an AOC.

With respect to soil, PCBs, VOCs, and pesticides are the primary COCs. The remediation goal for PCBs was set at 10,000 $\mu\text{g/kg}$ (this assumes a nonrestricted access area). Three areas within the operable unit have PCB concentrations in soil exceeding this goal. These areas are

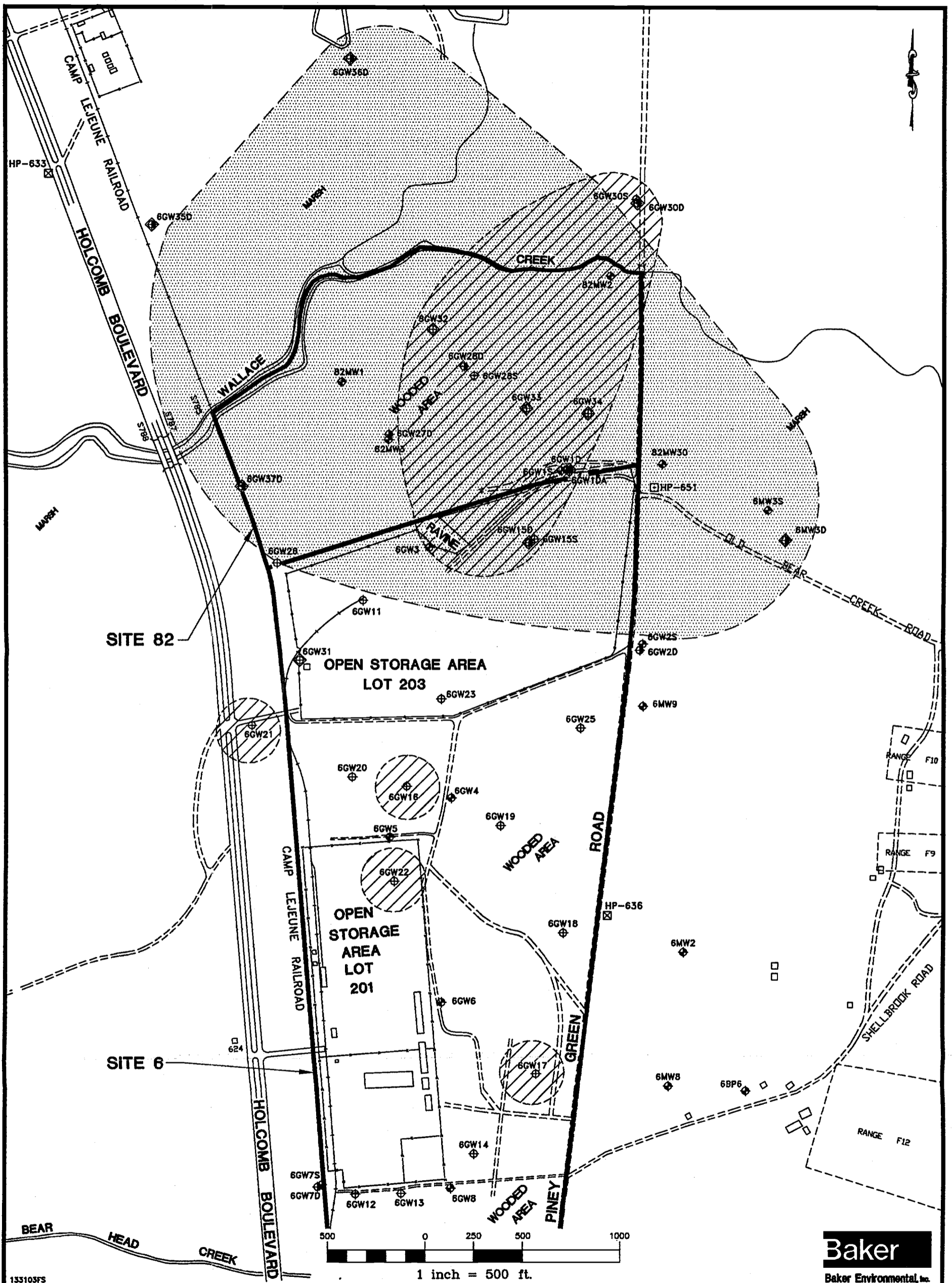

2-50

135103FS

LEGEND	
6GW15	EXISTING MONITORING WELL
6GW12	PHASE I SHALLOW MONITORING WELL
6GW10	PHASE I DEEP MONITORING WELL
HP-651	WATER SUPPLY WELL (CURRENTLY INACTIVE)
HP-636	WATER SUPPLY WELL (CURRENTLY ACTIVE)
6GW31	PHASE II SHALLOW MONITORING WELL
6GW1DA	PHASE II DEEP MONITORING WELL
(Dotted Area)	APPROXIMATE AREA OF GROUNDWATER (DEEPER PORTION) CONTAMINATION EXCEEDING REMEDIATION GOALS
(Hatched Area)	APPROXIMATE AREA OF GROUNDWATER (SHALLOW PORTION) CONTAMINATION EXCEEDING REMEDIATION GOALS

FIGURE 2-1
 APPROXIMATE LOCATION OF
 GROUNDWATER CONTAMINATION
 FEASIBILITY STUDY CTO-0133
 MARINE CORPS BASE, CAMP LEJEUNE
 NORTH CAROLINA



01483CC02Z

identified on Figure 2-2 as AOC3, AOC4, and AOC6. For this FS, each of these areas are estimated to be approximately 2,700 square feet in size. The vertical extent of contamination requiring remediation at AOC4 and AOC6 is 2 feet. The vertical extent for AOC3 is 4 feet. These estimations were based on the analytical results. Confirmation sampling would have to be conducted during remedial action to determine the actual horizontal and vertical extent of PCB contamination at these areas. For purposes of this FS, the volume of soil to be remediated from AOC3, AOC4, and AOC6 is 400 cubic yards, 200 cubic yards, and 200 cubic yards, respectively. In addition to the three PCB-contaminated AOCs for soil, three other areas have been identified as AOCs as shown on Figure 2-2. Soil AOC1 is a potential source of the ongoing groundwater contamination at Site 82. High levels of TCE and PCE were detected in the soil samples collected from this area. AOC1 also covers the area where buried drums were identified and are being removed as part of a Time Critical Removal Action. AOC1 is estimated to cover over 2.5 acres at a depth of 4 feet. Therefore, approximately 16,500 cubic yards of soil within this area will require remediation. Soil AOC2 (the upper portion of the ravine) has been identified as an area of concern due to detected levels of contaminants that may be a continuing source of PAH and metals contamination to the sediments in Wallace Creek. AOC2 is estimated to cover less than 0.5 acres at a depth of 2 feet. Therefore, approximately 1,500 cubic yards of soil within this area will require remediation. Soil AOC5 is an area of concern at Lot 201 based on the levels of pesticides detected in the soil samples. AOC5 is estimated to cover 2,700 square feet at a depth of 2 feet. Therefore, approximately 200 cubic yards of soil will be remediated.

2.4 Remedial Action Objectives

Based on the information presented in Sections 2.1 through 2.3, several remedial action objectives have been developed for OU No. 2 at MCB Camp Lejeune. These objectives are summarized of Table 2-24 per media of concern (groundwater and soil).

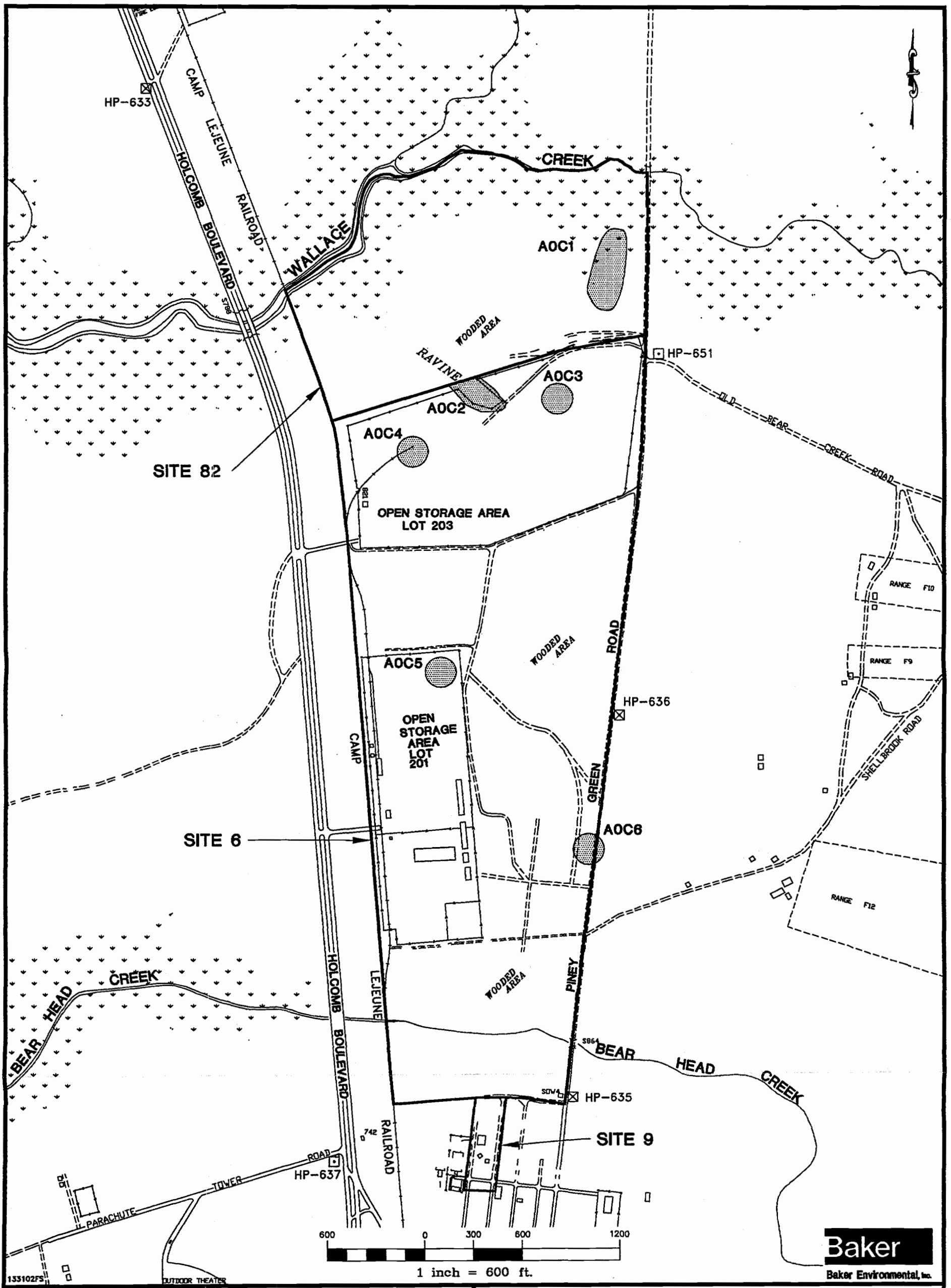

Baker
Baker Environmental, Inc.

LEGEND

HP-651	WATER SUPPLY WELL (CURRENTLY INACTIVE)
HP-637	WATER SUPPLY WELL (CURRENTLY ACTIVE)
AOC1	APPROXIMATE LOCATION OF SOIL AREAS OF CONCERN

FIGURE 2-2
APPROXIMATE LOCATION OF
SOIL AREAS OF CONCERN
FEASIBILITY STUDY CTO-0133
MARINE CORPS BASE, CAMP LEJEUNE
NORTH CAROLINA

SOURCE: LANTDIV, FEBRUARY 1992

01483 CC 032

TABLE 2-24

**REMEDIAL ACTION OBJECTIVES APPLICABLE TO OU No. 2
FEASIBILITY STUDY CTO-0133
MCB CAMP LEJEUNE, NORTH CAROLINA**

Media	Area of Concern	Remedial Action Objective
Groundwater	Surficial Aquifer and Castle Hayne Aquifer ⁽¹⁾	<ul style="list-style-type: none"> ● Prevent ingestion of water with groundwater COCs exceeding the remediation goals. ● Prevent the horizontal and vertical migration of contaminated groundwater in the aquifers. ● Restore the groundwater aquifer to meet the remediation goals set for the groundwater COCs.
Soil	AOC1 ⁽²⁾	<ul style="list-style-type: none"> ● Remediate the source of groundwater contamination at AOC1 to a level that is protective of groundwater.
	AOC1	<ul style="list-style-type: none"> ● Mitigate the risks associated with human contact with solvent-contaminated surficial soils at AOC1.
	AOC2	<ul style="list-style-type: none"> ● Remove soils that may be a potential source of surface water and sediment contamination to Wallace Creek.
	AOC3/AOC4	<ul style="list-style-type: none"> ● Mitigate the risks associated with human contact with PCB-contaminated soils at AOC3 and AOC4. ● Mitigate potential migration of PCB-contaminated soils at AOC3 and AOC4.
	AOC5	<ul style="list-style-type: none"> ● Mitigate the risks associated with human contact with pesticide-contaminated soils at AOC5.
	AOC5	<ul style="list-style-type: none"> ● Mitigate potential migration of pesticide-contaminated soils at AOC5.
	AOC6	<ul style="list-style-type: none"> ● Mitigate the risks associated with human contact with PCB-contaminated soils at AOC6.
	AOC6	<ul style="list-style-type: none"> ● Mitigate potential migration of PCB-contaminated soils at AOC6.

(1) There is no confining layer between the Surficial and Castle Hayne Aquifers at this operable unit. Therefore, both aquifers act as one water-bearing zone.

(2) AOC = Area of Concern. Refer to Section 2.3.5 for a description of each of these areas.

3.0 IDENTIFICATION AND PRELIMINARY SCREENING OF REMEDIAL TECHNOLOGIES

This section includes the identification and preliminary screening of a set of remedial action technologies that may be applicable for the remediation of the groundwater and soils at OU No. 2. Section 3.1 identifies a set of general response actions that may be applicable to the operable unit. Section 3.2 includes the identification of a set of remedial technologies applicable to groundwater remediation, and a set applicable to soil remediation. Section 3.3 presents the preliminary screening of the set of identified remedial technologies and process options. Section 3.4 presents a summary of the preliminary screening, and Section 3.5 presents the process option evaluation.

3.1 General Response Actions

General response actions are broad-based medium-specific categories of actions that can be identified to satisfy the remedial action objectives of an FS. The general response actions that will satisfy the remedial action objectives identified for OU No. 2 are listed on Table 3-1. As shown on the table, four general response actions have been identified for the groundwater objectives: no action, institutional controls, containment actions, and collection/treatment actions. Four response actions have also been identified for the soil objectives: no action, institutional controls, containment actions, and excavation/treatment actions.

A brief description of each of the above-mentioned general response actions follows.

3.1.1 No Action

The NCP requires the evaluation of the no action response action as part of the FS process. A no action response provides the baseline assessment for the comparison with other remedial alternatives that have a greater level of response. A no action alternative may be considered appropriate when an alternative response action may cause a greater environmental or health danger than the no action alternative itself.

3.1.2 Institutional Controls

Institutional controls are various "institutional" actions that can be implemented at a site as part of a complete remedial alternative to minimize exposure to potential hazards at the site.

TABLE 3-1

GENERAL RESPONSE ACTIONS FOR OPERABLE UNIT NO. 2
 FEASIBILITY STUDY CTO-0133
 MCB CAMP LEJEUNE, NORTH CAROLINA

Media	Area of Concern	Remedial Action Objective	General Response Action
Groundwater	Surficial and Castle Hayne Aquifers ⁽¹⁾	<ul style="list-style-type: none"> ● Prevent ingestion of water with groundwater COCs exceeding the remediation goals. ● Prevent the horizontal and vertical migration of contaminated groundwater in the Surficial and Castle Hayne Aquifers. ● Restore the groundwater aquifer to meet the remediation goals set for the groundwater COCs. 	<ul style="list-style-type: none"> ● No Action ● Institutional Controls ● Containment Actions ● Collection/Treatment Actions
Soil	AOC ⁽²⁾	<ul style="list-style-type: none"> ● Remediate the source of groundwater contamination at AOC1 to a level that is protective of groundwater. 	<ul style="list-style-type: none"> ● No Action ● Institutional Controls ● Containment Actions ● Excavation/Treatment Actions
	AOC1	<ul style="list-style-type: none"> ● Mitigate the risks associated with human contact with solvent-contaminated surficial soils at AOC1. 	
	AOC2	<ul style="list-style-type: none"> ● Remove soils that may be a potential source of surface water and sediment contamination to Wallace Creek. 	
	AOC3/AOC4	<ul style="list-style-type: none"> ● Mitigate the risks associated with human contact with PCB- contaminated soils at AOC3 and AOC4. 	
	AOC3/AOC4	<ul style="list-style-type: none"> ● Mitigate potential migration of PCB-contaminated soils at AOC3 and AOC4 	
	AOC5	<ul style="list-style-type: none"> ● Mitigate the risks associated with human contact with pesticide-contaminated soils at AOC5. 	
	AOC5	<ul style="list-style-type: none"> ● Mitigate potential migration of pesticide-contaminated soils at AOC5. 	
	AOC6	<ul style="list-style-type: none"> ● Mitigate the risks associated with human contact with PCB-contaminated soils at AOC6. ● Mitigate potential migration of PCB-contaminated soils at AOC6. 	

3-2

(1) There is no confining layer between the Surficial and Castle Hayne Aquifers at this operable unit. Therefore, both aquifers act as one water bearing zone.

(2) AOC = Area of Concern. Refer to Section 2.3.5 for a description of each of these areas.

With respect to groundwater, institutional controls may include monitoring programs, ordinances and access restrictions. With respect to soil, institutional controls may include monitoring and access restrictions.

3.1.3 Containment Actions

Containment measures include various technologies which contain and/or isolate the COCs on a site. The measures are designed to isolate so as to prevent direct exposure with or migration of the contaminated media without disturbing or removing the waste from the site. Containment actions generally serve to cover, seal, chemically stabilize, or provide an effective barrier against specific areas of contamination. These actions may be applicable to both media of concern (soil and groundwater) at OU No. 2.

3.1.4 Collection/Treatment Actions

Collection/treatment actions are typically associated with groundwater or surface water. For this FS, only groundwater collection/treatment actions will be addressed. For groundwater, collection/treatment actions may include one of the following options: (1) collecting the contaminated groundwater, treating it on site, and then discharging or reinjecting it; (2) collecting the groundwater and then treating it off site; and (3) treating the groundwater in situ.

3.1.5 Excavation/Treatment Actions

Excavation/treatment actions are typically associated with soil, sediment, or solid wastes. For this FS, only soil excavation/treatment actions will be addressed. With respect to soil, excavation/treatment actions may include one of the following options: (1) excavating contaminated soil, treating it on site, and then disposing of treated residuals either on or off site; (2) excavating the soil and then treating and disposing it off site; and (3) treating the soil in situ.

3.2 Identification of Remedial Action Technologies and Process Options

In this step, an extensive set of potentially applicable technology types and process options will be identified for each of the general response actions identified for the media of concern at OU No. 2. The term "technology type" refers to general categories of technologies such as

chemical treatment, thermal treatment, biological treatment, and in situ treatment. The term "technology process option" refers to specific processes within each technology type, for example rotary kiln, fluidized bed, and multiple hearth incineration are process options of thermal treatment. Several technology types may be identified for each general response action, and numerous technology process options may exist within each technology type.

Remedial action technologies potentially applicable to OU No. 2 are listed on Table 3-2 with respect to their corresponding general response action. The applicable process options associated with each of the listed technologies are also listed on the table.

3.3 Preliminary Screening of Remedial Action Technologies and Process Options

In this step, the set of remedial action technologies and process options identified in the previous section will be reduced (or screened) by evaluating the technologies with respect to technical implementability and site-specific factors. This screening step is site-specific and will be accomplished by using readily available information from the RI with respect to contaminant types, contaminant concentrations and on-site characteristics to screen out technologies and process options that cannot be effectively implemented at the site (USEPA, 1988a). In general, all technologies/options which appear to be applicable to the site contaminants and to the site conditions will be retained for further evaluation. The preliminary screening is presented on Tables 3-3 and 3-4 for groundwater and soil, respectively. Each of the process options remaining following the preliminary screening will be evaluated in Section 3.4.

As shown on Tables 3-3 and 3-4, several technologies and/or process options were eliminated from further evaluation since they were determined to be inappropriate for the site-specific characteristics and/or contaminant-specific characteristics of OU No. 2. The groundwater technologies/options that were eliminated include:

- Capping
- Vertical Barriers
- Horizontal Barriers
- Reverse Osmosis
- Oil/Water Separation
- Chemical Dechlorination
- Plasma Arc Torch
- Pyrolysis
- Wet Air Oxidation
- In Situ Biodegradation

TABLE 3-2

POTENTIAL SET OF REMEDIAL ACTION TECHNOLOGIES AND
 PROCESS OPTIONS IDENTIFIED FOR OPERABLE UNIT NO. 2
 FEASIBILITY STUDY CTO-0133
 MCB CAMP LEJEUNE, NORTH CAROLINA

Media	General Response Action	Remedial Action Technology	Process Option	
Groundwater	No Action	No Action	No Applicable	
	Institutional Controls	Monitoring	Groundwater Monitoring	
		Ordinances	Aquifer-Use Restrictions	
		Access Restrictions	Deed Restrictions Fencing	
	Containment Actions	Capping	Clay/Soil Cap	Clay/Soil Cap
			Asphalt/Concrete Cap	Asphalt/Concrete Cap
			Soil Cover	Soil Cover
			Multilayered Cap	Multilayered Cap
		Vertical Barriers	Grout Curtain	Grout Curtain
			Slurry Wall	Slurry Wall
			Sheet Piling	Sheet Piling
			Rock Grouting	Rock Grouting
		Horizontal Barriers	Grout Injection	Grout Injection
			Block Displacement	Block Displacement
	Extraction	Extraction Wells	Extraction Wells	
		Subsurface Drains	Interceptor Trenches	Interceptor Trenches
			Discharge	Reinjection
		Injection Wells		● Injection Wells
		Infiltration Galleries		● Infiltration Galleries
	Collection/Treatment Actions	Extraction	Extraction Wells	
		Subsurface Drains	Interceptor Trenches	
		Biological Treatment	Aerobic	Aerobic
			Anaerobic	Anaerobic
Physical/Chemical Treatment		Air Stripping	Air Stripping	
		Steam Stripping	Steam Stripping	
		Carbon Adsorption	Carbon Adsorption	
		Reverse Osmosis	Reverse Osmosis	
		Ion Exchange	Ion Exchange	
		Chemical Reduction	Chemical Reduction	
		Chemical Oxidation	Chemical Oxidation	
		Neutralization	Neutralization	
		Precipitation	Precipitation	
		Oil/Water Separator	Oil/Water Separator	
	Filtration	Filtration		
	Flocculation	Flocculation		
Sedimentation	Sedimentation			
Chemical Dechlorination	Chemical Dechlorination			

TABLE 3-2 (Continued)

POTENTIAL SET OF REMEDIAL ACTION TECHNOLOGIES AND
 PROCESS OPTIONS IDENTIFIED FOR OPERABLE UNIT NO. 2
 FEASIBILITY STUDY CTO-0133
 MCB CAMP LEJEUNE, NORTH CAROLINA

Media	General Response Action	Remedial Action Technology	Process Option
Groundwater (Cont)	Collection/Treatment Actions (Cont)	Thermal Treatment	Incineration
			● Liquid Injection
			● Rotary Kiln
			● Fluidized Bed
			● Multiple Hearth
		Molten Salt	
		Plasma Arc Torch	
		Pyrolysis	
		Wet Air Oxidation	
		Off-Site Treatment	POTW
			RCRA Facility
			Sewage Treatment Plant
		In Situ Treatment	Biodegradation
			Air Sparging
		On-Site Discharge	Surface Water (Wallace Creek)
Reinjection			
● Injection Wells ● Infiltration Galleries			
Off-Site Discharge	POTW		
	Pipeline to River (New River)		
	Sewage Treatment Plant		
	Drinking Water Plant		
	Deep Well Injection		
Soil	No Action	No Action	Not Applicable
	Institutional Controls	Monitoring	Monitoring
		Access Restriction	Deed Restrictions Fencing
	Containment Actions	Capping	Clay/Soil Cap
			Asphalt/Concrete Cap
			Soil Cover
		Multilayered Cap	
	Surface Controls	Grading Revegetation	
	Excavation/Treatment Actions	Excavation	Soils Excavation
		Biological Treatment	Land Treatment Composting (Bio Piling)
		Physical/ Chemical Treatment	Solidification/Stabilization
			● Cement-Based Processes
			● Polymer-Based Processes
	● Silicate-Based Processes		
	● Thermoplastic Techniques		
● Surface Microencapsulation			
● Vitrification			
Soil Washing (Solvent Washing/ Extraction)			
Chemical Dechlorination (KPEG)			

TABLE 3-2 (Continued)

POTENTIAL SET OF REMEDIAL ACTION TECHNOLOGIES AND
 PROCESS OPTIONS IDENTIFIED FOR OPERABLE UNIT NO. 2
 FEASIBILITY STUDY CTO-0133
 MCB CAMP LEJEUNE, NORTH CAROLINA

Media	General Response Action	Remedial Action Technology	Process Option
Soil (Cont)	Excavation/Treatment Actions (Cont)	Thermal Treatment	Incineration
			● Rotary Kiln
			● Fluidized Bed
			Low Temperature Thermal Stripper
			Molten Salt
			Plasma Arc Torch
			Infrared Incineration
		In Situ Treatment	Pyrolysis
			Wet Air Oxidation
			Biodegradation
			Volatilization (Vapor Extraction)
			Soil Flushing
			Chemical Immobilization
			● Polymerization
		● Precipitation	
Off-Site Treatment/Disposal	Chemical Detoxification		
	● Oxidation		
	● Reduction		
	● Neutralization		
● Hydrolysis			
Vitrification			
Heating			
Artificial Ground Freezing			
RCRA Facility			
Landfill			
● Hazardous			
● Nonhazardous			

TABLE 3-3

PRELIMINARY SCREENING OF GROUNDWATER TECHNOLOGIES AND PROCESS OPTIONS
 FEASIBILITY STUDY CTO-0133
 MCB CAMP LEJEUNE, NORTH CAROLINA

General Response Action	Remedial Action Technology	Process Option	Description	Site-Specific Applicability	Screening Results
No Action	No Action	Not Applicable	No action - contaminated groundwater remains as is.	Potentially applicable to any site; required by the NCP.	Retained
Institutional Controls	Monitoring Ordinances	Groundwater Monitoring	Ongoing monitoring of existing wells.	Potentially applicable.	Retained
		Aquifer-Use Restrictions	Prohibit the use of the contaminated aquifer as a drinking water source.	Potentially applicable.	Retained
	Access Restrictions	Deed Restrictions	Limit the future use of land including placement of wells.	Potentially applicable.	Retained
		Fencing	Limit access by installing a fence around contaminated area.	Potentially applicable; some fencing already exists.	Retained
Containment Actions	Capping	Clay/Soil Cap Asphalt/Concrete Cap Soil Cover Multilayered Cap	Capping material placed over areas of contamination.	Does not appear to be applicable for contaminated groundwater based on the large plume area and depth of the contamination.	Eliminated
		Vertical Barriers	Grout Curtain	Pressure injection of grout in a regular pattern of drilled holes to contain contamination.	The heterogeneity of the fill material at the Operable Unit may prevent a "gap-free" curtain. No continuous confining layer under the sites for the wall to adjoin to.
	Slurry Wall		Trench around areas of contamination. The trench is filled with a soil bentonite slurry to limit migration of contaminants.	The heterogeneity of the fill material at the Operable Unit may prevent a "gap-free" curtain. No continuous confining layer under the sites for the wall to adjoin to.	Eliminated
	Sheet Piling		Interlocking sheet pilings installed via drop hammer around areas of contamination.	No continuous confining layer under the sites for the wall to adjoin to.	Eliminated
	Rock Grouting		Specialty operation for sealing fractures, fissures, solution cavities, or other voids in rock to control flow of groundwater.	No rock at the sites.	Eliminated
	Horizontal Barriers		Grout Injection	Pressure injection of grout to form a bottom seal across a site at a specific depth.	Technique is in the experimental stage. Depth of the contaminated groundwater at the sites would limit its use.
		Block Displacement	Continued pumping of grout into specially notched holes causing displacement of a block of contaminated earth.	Depth of contaminated groundwater would limit its use. Technique is in the experimental stage.	Eliminated

TABLE 3-3 (Continued)

PRELIMINARY SCREENING OF GROUNDWATER TECHNOLOGIES AND PROCESS OPTIONS
FEASIBILITY STUDY CTO-0133
MCB CAMP LEJEUNE, NORTH CAROLINA

General Response Action	Remedial Action Technology	Process Option	Description	Site-Specific Applicability	Screening Results
Containment Actions (cont)	Extraction	Extraction Wells	Series of wells used to extract contaminated groundwater.	Potentially applicable	Retained
	Subsurface Drains	Interceptor Trenches	Perforated pipe installed in trenches backfilled with porous media to collect contaminated groundwater.	Depth of the contaminated groundwater will limit its use. Applicable to only the shallow groundwater. May be applicable for preventing migration of groundwater to Wallace Creek and/or Bear Head Creek.	Retained
	Discharge	Reinjection: • Injection Wells • Infiltration Galleries	The extracted groundwater can be reinjected back into the aquifer (following some treatment) to enhance the collection of contaminated groundwater via extraction wells.	Potentially applicable	Retained
Collection/Treatment Actions	Extraction	Extraction Wells	Series of wells used to extract contaminated groundwater.	Potentially applicable	Retained
		Extraction/Injection Wells	Injection wells inject uncontaminated groundwater to enhance collection of contaminated groundwater via the extraction wells. Or the injection wells can also inject material into an aquifer to remediate groundwater.	Potentially applicable	Retained
	Subsurface Drains	Interceptor Trenches	Perforated pipe installed in trenches backfilled with porous media to collect contaminated groundwater.	Depth of the contaminated groundwater will limit its use. Applicable to only the shallow groundwater. May be applicable for preventing migration of groundwater to Wallace Creek and/or Bear Head Creek.	Retained
	Biological Treatment	Aerobic	Degradation of organics using microorganisms in an aerobic environment.	Potentially applicable to organic contaminants of concern.	Retained
		Anaerobic	Degradation of organics using microorganisms in an anaerobic environment.	Potentially applicable to some of the groundwater contaminants of concern (multichlorinated compounds with three or more chlorines). Possible use as pretreatment for aerobic treatment.	Retained

TABLE 3-3 (Continued)

PRELIMINARY SCREENING OF GROUNDWATER TECHNOLOGIES AND PROCESS OPTIONS
 FEASIBILITY STUDY CTO-0133
 MCB CAMP LEJEUNE, NORTH CAROLINA

General Response Action	Remedial Action Technology	Process Option	Description	Site-Specific Applicability	Screening Results
Collection/Treatment Actions (cont)	Physical/Chemical Treatment	Air Stripping	Mixing large volumes of air with water in a packed column to promote transfer of VOCs to air. Applicable to volatile organics and some SVOCs.	Potentially applicable for VOCs and selected number of SVOCs.	Retained
		Steam Stripping	Mixing large volumes of steam with water in a packed column to promote transfer of VOCs to air. Applicable to a wide range of organics.	Potentially applicable for VOCs and selected number of SVOCs.	Retained
		Carbon Adsorption	Adsorption of contaminants onto activated carbon by passing water through carbon column. Applicable to wide range of organics.	Potentially applicable	Retained
		Reverse Osmosis	Using high pressure to force water through a membrane leaving contaminants behind. Applicable to dissolved solids (organic and inorganic).	Not applicable for most of the constituents of concern.	Eliminated
		Ion Exchange	Contaminated water is passed through a resin bed where ions are exchanged between resin and water. Applicable for inorganics, not organics.	Potentially applicable	Retained
		Chemical Reduction	Addition of a reducing agent to lower the oxidation state of a substance to reduce toxicity/solubility. Applicable to chromium, mercury and lead.	Potentially applicable	Retained
		Chemical Oxidation	Addition of an oxidizing agent to raise the oxidation state of a substance. Applicable to cyanide, organics, and some inorganics.	Potentially applicable	Retained
		Neutralization	Addition of an acid or base to a waste in order to adjust its pH. Applicable to acidic or basic waste streams.	Although pH is not a concern at the operable unit, neutralization may be applicable in a treatment train with precipitation.	Retained
		Precipitation	Materials in solution are transferred into a solid phase for removal. Applicable to particulates and metals.	Potentially applicable for inorganics.	Retained
		Oil/Water Separation	Materials in solution are transferred into a separate phase for removal. Applicable to petroleum hydrocarbons.	Not necessary for the contaminants of concern. No free phase product detected at the sites.	Eliminated

TABLE 3-3 (Continued)

PRELIMINARY SCREENING OF GROUNDWATER TECHNOLOGIES AND PROCESS OPTIONS
 FEASIBILITY STUDY CTO-0133
 MCB CAMP LEJEUNE, NORTH CAROLINA

General Response Action	Remedial Action Technology	Process Option	Description	Site-Specific Applicability	Screening Results
Collection/Treatment Actions (cont)	Physical/Chemical Treatment (cont)	Filtration	Removal of suspended solids from solution by forcing the liquid through a porous medium. Applicable to suspended solids.	Potentially applicable	Retained
		Flocculation	Small, unsettleable particles suspended in a liquid medium are made to agglomerate into larger particles by the addition of flocculating agents. Applicable to particulates and inorganics.	Potentially applicable	Retained
		Sedimentation	Removal of suspended solids in an aqueous waste stream via gravity separation. Applicable to suspended solids.	Potentially applicable	Retained
		Chemical Dechlorination (KPEG)	Process which uses specially synthesized chemical reagents to destroy hazardous chlorinated molecules or to toxify them to form other less harmful compounds. Applicable to PCBs, chlorinated hydrocarbons and dioxins.	Not applicable to the groundwater contaminants of concern.	Eliminated
	Thermal Treatment	Incineration <ul style="list-style-type: none"> ● Liquid Injection ● Rotary Kiln ● Fluidized Bed ● Multiple Hearth 	Combustion of waste at high temperatures. Different incinerator types can be applicable to pumpable organic wastes, combustible liquids, soils, slurries, or sludges.	Potentially applicable	Retained
		Molten Salt	Advanced incineration; waste contacts hot molten salt to undergo catalytic destruction. Applicable for hazardous liquids, low ash, high chlorine wastes.	Potentially applicable	Retained
		Plasma Arc Torch	Advanced incineration; pyrolyzing wastes into combustible gases in contact with a gas which has been energized to its plasma state by an electrical discharge. Applicable for liquid organic waste.	Lack of operational experience	Eliminated

TABLE 3-3 (Continued)

PRELIMINARY SCREENING OF GROUNDWATER TECHNOLOGIES AND PROCESS OPTIONS
 FEASIBILITY STUDY CTO-0133
 MCB CAMP LEJEUNE, NORTH CAROLINA

General Response Action	Remedial Action Technology	Process Option	Description	Site-Specific Applicability	Screening Results
Collection/Treatment Actions (cont)	Thermal Treatment	Pyrolysis	Advanced incineration; thermal conversion of organic material into solid, liquid, and gaseous components; takes place in an oxygen-deficient atmosphere. Applicable for organics and inorganics.	Typically used for compounds not conducive to conventional incineration; Operable Unit No. 2 compounds are suitable to other incineration methods.	Eliminated
		Wet Air Oxidation	Advanced incineration; aqueous phase oxidation of dissolved or suspended organic substances at elevated temperatures and pressures. Applicable for organics with high COD, high strength wastes, and for oxidizable inorganics.	Not recommended for treating large volumes of water.	Eliminated
	Off-site Treatment	POTW	Extracted groundwater discharged to Jacksonville POTW for treatment.	Potentially applicable	Retained
		RCRA Facility	Extracted groundwater discharged to licensed RCRA facility for treatment and/or disposal.	Potentially applicable	Retained
		Sewage Treatment Plant	Extracted groundwater discharged to Hadnot Point STP for treatment.	Potentially applicable	Retained
	In Situ Treatment	Biodegradation	System of introducing nutrients and oxygen to waste for the stimulation or augmentation of microbial activity to degrade contamination. Applicable to a wide range of organic compounds.	Potentially applicable to shallow aquifer. This technology is at the experimental stage for treatment of deeper aquifers.	Eliminated
		Air Sparging	"In Situ Air Stripping". Used in combination with treatment of soils in the unsaturated zone. Applicable to organics.	Potentially applicable as a shallow aquifer technology. In deep zones, well spacing requirements make the use cost prohibitive.	Retained
	On-Site Discharge	Surface Water	Treated water discharged to stream on the site (i.e., Wallace Creek).	Potentially applicable	Retained
		Reinjection • Injection Wells • Infiltration Galleries	Treated water reinjection into the site aquifer via use of shallow infiltration galleries (trenches) or via deep injection wells.	Deep injection wells potentially applicable. Site geology and low water table may prohibit the use of infiltration galleries.	Retained
		POTW	Treated water discharged to Jacksonville POTW.	Potentially applicable	Retained

TABLE 3-3 (Continued)

PRELIMINARY SCREENING OF GROUNDWATER TECHNOLOGIES AND PROCESS OPTIONS
 FEASIBILITY STUDY CTO-0133
 MCB CAMP LEJEUNE, NORTH CAROLINA

General Response Action	Remedial Action Technology	Process Option	Description	Site-Specific Applicability	Screening Results
Collection/Treatment Actions (cont)	Off-Site Discharge	Pipeline to River	Treated water discharged to river off site (i.e., New River).	Potentially applicable	Retained
		Sewage Treatment Plant	Treated water discharged to Hadnot Point Sewage Treatment Plant	Potentially applicable	Retained
		Drinking Water Plant	Treated water discharged to Camp Lejeune Drinking Water Treatment Plant	Potentially applicable	Retained
		Deep Well Injection	Treated water is reinjected into the brine aquifer located under the Castle Hayne Aquifer.	Potentially applicable	Retained

TABLE 3-4

PRELIMINARY SCREENING OF SOIL TECHNOLOGIES AND PROCESS OPTIONS
 FEASIBILITY STUDY CTO-0133
 MCB CAMP LEJEUNE, NORTH CAROLINA

General Response Action	Remedial Action Technology	Process Option	Description	Site-Specific Applicability	Screening Results
No Action	No Action	Not Applicable	No Action - contaminated soil remains untreated.	Potentially applicable to any site; required by NCP.	Retained
Institutional Controls	Monitoring	Monitoring	Periodic sampling and analyses.	Potentially applicable	Retained
	Access Restrictions	Deed Restrictions	Limit future land use in areas with soil contamination.	Potentially applicable	Retained
		Fencing	Limit access by installing fencing around contaminated areas.	Potentially applicable; some fencing already exists	Retained
Containment Actions	Capping	Clay/Soil Cap	Compacted impermeable clay layer covered with soil installed over contaminated area.	Potentially applicable - vegetation and Piney Green Road may interfere with implementation.	Retained
		Asphalt/Concrete Cap	Spray a layer of asphalt over contaminated areas or seal the area with concrete.	Potentially applicable - vegetation and Piney Green Road may interfere with implementation.	Retained
		Soil Cover	Soil layer placed on existing ground surface to seal off contamination from aboveground surface.	Potentially applicable - vegetation and Piney Green Road may interfere with implementation.	Retained
		Multilayered Cap	Clay and synthetic membrane placed over contaminated area. Areas then covered with soil and revegetated.	Potentially applicable - vegetation and Piney Green Road may interfere with implementation.	Retained
	Surface Controls	Grading	Modifying the natural topography and run-off characteristics on and around contaminated areas to control infiltration and erosion due to surface water.	Potentially applicable - could be used in conjunction with a capping option. Alone, does not address soil contamination.	Retained
		Revegetation	Establish a vegetative cover over contaminated areas to stabilize the ground surface	Potentially applicable - in conjunction with other process options. Alone, does not address soil contamination.	Retained
Excavation/Treatment Actions	Excavation	Soils Excavation	Mechanically remove contaminated soils from ground.	Potentially applicable - useful in conjunction with other process options.	Retained

TABLE 3-4 (Continued)

PRELIMINARY SCREENING OF SOIL TECHNOLOGIES AND PROCESS OPTIONS
 FEASIBILITY STUDY CTO-0133
 MCB CAMP LEJEUNE, NORTH CAROLINA

General Response Action	Remedial Action Technology	Process Option	Description	Site-Specific Applicability	Screening Results
Excavation/Treatment Actions (Cont.)	Biological Treatment	Land Treatment	Spread contaminated soil over land and rely on natural microbial action to degrade waste.	Not applicable - not proven for PCB contaminated soils - extensive treatability studies required. Applicable primarily for organic compounds.	Retained for organic contamination only.
		Composting (Bio Piling)	Aboveground soil management technique where contaminated soils containing organic wastes are mixed with bulking agents, placed in large piles and aerated.	Not applicable - not proven for PCB contaminated soils. Applicable primarily for organic compounds.	Retained for organic contamination only.
	Physical/Chemical Treatment	Solidification/Stabilization <ul style="list-style-type: none"> • Cement-Based Processes • Polymer-Based Processes • Silicate-Based Processes • Thermoplastic Techniques • Surface Microencapsulation • Vitrification 	Methods by which additives are incorporated into the contaminated soils to encapsulate the compounds of concern.	Potentially applicable primarily for inorganic compounds. Technology is in developmental stage for most organic compounds.	Retained
		Soil Washing (Solvent Washing/Extraction)	The extraction of contaminants from excavated soil by mixing the soil with water, solvents, surfactants, or chelating agents.	Potentially applicable	Retained
		Chemical Dechlorination (KPEG)	Process which uses specially synthesized chemical reagents to destroy hazardous chlorinated molecules or to detoxify them to form other less harmful compounds. Applicable to PCBs, chlorinated hydrocarbons and dioxins.	Potentially applicable for PCB contaminated soils.	Retained
	Thermal Treatment	Incineration <ul style="list-style-type: none"> • Rotary Kiln • Fluidized Bed 	Combustion of waste at high temperatures. Suitable for soils, sludges, slurries.	Potentially applicable	Retained
		Low Temperature Thermal Stripper	Combustion of volatile compounds without heating the soil matrix to combustion temperatures.	Not applicable, potential formation of dioxins at low temperatures for PCB contaminated soils.	Eliminated
		Molten Salt	Advanced incineration; waste contacts hot molten salt to undergo catalytic destruction.	Potentially applicable	Retained

TABLE 3-4 (Continued)

PRELIMINARY SCREENING OF SOIL TECHNOLOGIES AND PROCESS OPTIONS
 FEASIBILITY STUDY CTO-0133
 MCB CAMP LEJEUNE, NORTH CAROLINA

General Response Action	Remedial Action Technology	Process Option	Description	Site-Specific Applicability	Screening Results
Excavation/Treatment Actions (Cont.)	Thermal Treatment (Cont.)	Plasma Arc Torch	Advanced incineration; destroys wastes by pyrolyzing them into combustible gases in contact with a gas which has been energized.	Not applicable for soils -- only for pumpable organic wastes and finely divided, fluidized sludges.	Eliminated
		Infrared Incineration	Advanced incineration; destroys wastes by using silicon carbide elements to generate thermal radiation.	Potentially applicable	Retained
		Pyrolysis	Advanced incineration; thermal conversion of organic material into solid, liquid, and gaseous components; takes place in oxygen-deficient atmosphere.	Potentially applicable	Retained
		Wet Air Oxidation	Advanced incineration; aqueous phase oxidation of dissolved or suspended organic substances at elevated temperatures and pressures.	Not applicable for soils -- typically for wastewater sludges.	Eliminated
	In Situ Treatment	Biodegradation	System of introducing nutrients and oxygen to waste for the stimulation or augmentation of microbial activity to degrade contamination. Applicable to a wide range of organic compounds.	Potentially applicable	Retained
		Volatilization (Vapor Extraction)	Volatile compounds are removed from subsurface soils by mechanically drawing or venting air through the soil matrix.	Not applicable to PCB contaminated soils. Potentially applicable to the VOC contaminated soils.	Retained for VOC contaminated soils only.
		Soil Flushing	"In Situ" soil washing. An aqueous solution is injected into or sprayed onto the affected area and is collected downgradient, then treated.	Potentially applicable	Retained
		Chemical Immobilization • Polymerization • Precipitation	Techniques which render contaminants insoluble and thereby prevent migration.	Not applicable to PCB contaminated soils.	Eliminated
		In Situ Chemical Detoxification • Oxidation • Reduction • Neutralization • Hydrolysis	Techniques which destroy, degrade, or reduce the toxicity of contaminants by the use of various treatment agents.	Not applicable to PCB contaminated soils.	Eliminated

TABLE 3-4 (Continued)

PRELIMINARY SCREENING OF SOIL TECHNOLOGIES AND PROCESS OPTIONS
 FEASIBILITY STUDY CTO-0133
 MCB CAMP LEJEUNE, NORTH CAROLINA

General Response Action	Remedial Action Technology	Process Option	Description	Site-Specific Applicability	Screening Results
Excavation/Treatment Actions (Cont.)	In Situ Treatment (Cont.)	Vitrification	Emerging technology; contaminated soil is converted into a durable glass and crystalline form by melting the soil by electrical heat.	Potentially applicable	Retained
		Heating	Emerging technology; destroys or removes organic contaminants in soil through thermal decomposition, vaporization, and distillation.	May not be applicable to PCB contaminated soils.	Eliminated
		Artificial Ground Freezing	Emerging technology; involves installing freezing loops in the ground with a self-contained refrigeration system that pumps coolant around the loops. Soils around the wastes are frozen. Temporary treatment.	May not be applicable to PCB contaminated soils. Not a permanent solution.	Eliminated
	Off-Site Treatment/Disposal	RCRA Facility	Excavated soils are transported to a licensed RCRA facility for treatment and/or disposal.	Potentially applicable	Retained
		Landfill	Excavated soils are transported to a permitted landfill for disposal either hazardous or nonhazardous.	Potentially applicable	Retained

The soil technologies/options that were eliminated include:

- Low Temperature Thermal Stripper
- Plasma Arc Torch
- Wet Air Oxidation
- In Situ Chemical Immobilization
- In Situ Chemical Detoxification
- In Situ Heating
- Artificial Ground Freezing

The technologies and process options that passed this preliminary screening are listed on Table 3-5.

3.4 Process Option Evaluation

The objective of the process option evaluation is to select only one process option for each applicable remedial technology type to simplify the subsequent development and evaluation of alternatives without limiting flexibility during remedial design. More than one process option may be selected for a technology type if the processes are sufficiently different in their performance that one would not adequately represent the other. The representative process provides a basis for developing performance specifications during preliminary design; however the specific process option used to implement the remedial action may not be selected until the remedial design phase.

The process options listed on Table 3-5 were evaluated based on effectiveness, implementability, and relative cost. The effectiveness evaluation focussed on: the potential effectiveness of process options in meeting the remedial action objectives; the potential impacts to human health and the environment during the construction and implementation phase; and how reliable the process is with respect to the contaminants of concern. The implementability evaluation focussed on the administrative feasibility of implementing a technology (e.g., obtaining permits), since the technical implementability was previously considered in the preliminary screening. The cost evaluation played a limited role in this screening. Only relative capital and operating and maintenance (O&M) costs were used instead of detailed estimates. Per the USEPA FS guidance, the cost analysis was made on the basis of engineering judgment.

TABLE 3-5

**SET OF POTENTIAL TECHNOLOGIES/PROCESS OPTIONS
 THAT PASSED THE PRELIMINARY SCREENING
 FEASIBILITY STUDY CTO-0133
 MCB CAMP LEJEUNE, NORTH CAROLINA**

Media	General Response Action	Remedial Action Technology	Process Option
Groundwater	No Action	No Action	Not Applicable
	Institutional Controls	Monitoring	Groundwater Monitoring
		Ordinances	Aquifer-Use Restrictions
		Access Restrictions	Deed Restrictions Fencing
	Containment Actions	Extraction	Extraction Wells
		Subsurface Drains	Interceptor Trenches
		Discharge	Reinjection ● Injection wells
	Collection/Treatment Actions	Extraction	Extraction Wells
		Subsurface Drains	Interceptor Trenches
		Biological Treatment	Aerobic
			Anaerobic
		Physical/Chemical Treatment	Air Stripping
			Steam Stripping
			Carbon Adsorption
			Ion Exchange
			Chemical Reduction
			Chemical Oxidation
			Neutralization
			Precipitation
			Filtration
			Flocculation
		Sedimentation	
		Thermal Treatment	Incineration
	Molten Salt		
	Off-Site Treatment	POTW	
		RCRA Facility	
		Sewage Treatment Plant	
In Situ Treatment	Air Sparging		
On-Site Discharge	Surface Water		
	Reinjection ● Injection wells		
Off-Site Discharge	POTW		
	Pipeline to River		
	Sewage Treatment Plant		
	Drinking Water Plant		

TABLE 3-5 (Continued)

SET OF POTENTIAL TECHNOLOGIES/PROCESS OPTIONS
 THAT PASSED THE PRELIMINARY SCREENING
 FEASIBILITY STUDY CTO-0133
 MCB CAMP LEJEUNE, NORTH CAROLINA

Media	General Response Action	Remedial Action Technology	Process Option
Soils	No Action	No Action	Not Applicable
	Institutional Controls	Monitoring	Monitoring
		Access Restrictions	Deed Restrictions Fencing
	Containment Actions	Capping	Clay/Soil Cap
			Asphalt/Concrete Cap
			Soil Cover
			Multilayered Cap
	Excavation/Treatment Actions	Surface Controls	Grading Revegetation
		Excavation	Soils Excavation
			Biological Treatment
		Physical/Chemical Treatment	Solidification/Stabilization
			Soil Washing
			Chemical Dechlorination (KPEG)
		Thermal Treatment	Incineration
			Molten Salt
			Infrared Incineration
			Pyrolysis
		In Situ Treatment	Biodegradation
			Volatilization
	Soil Flushing		
Vitrification			
Off-Site Treatment/Disposal	RCRA Facility		
	Landfill		
		<ul style="list-style-type: none"> ● Hazardous ● Nonhazardous 	

A summary of the process option evaluation is presented on Tables 3-6 and 3-7 for groundwater and soil, respectively. It is important to note that the elimination of a process option does not mean that the process option/technology can never be reconsidered for the site. As previously stated, the purpose of this part of the FS process is to simplify the development and evaluation of potential alternatives.

Table 3-8 identifies the screened set of technologies/process options that will be used to develop potential remedial alternatives in Section 4.0.

TABLE 3-6

SUMMARY OF GROUNDWATER PROCESS OPTION EVALUATION
 FEASIBILITY STUDY CTO-0133
 MCB CAMP LEJEUNE, NORTH CAROLINA

General Response Action	Remedial Action Technology	Process Option	Evaluation			Evaluation Results
			Effectiveness	Implementability	Cost	
No Action	No Action	Not Applicable	Evaluation not necessary since only one process option	Evaluation not necessary since only one process option	Evaluation not necessary since only one process option	Retained
Institutional Controls	Monitoring	Groundwater Monitoring	Evaluation not necessary since only one process option	Evaluation not necessary since only one process option	Evaluation not necessary since only one process option	Retained
	Ordinances	Aquifer-Use Restrictions	Evaluation not necessary since only one process option	Evaluation not necessary since only one process option	Evaluation not necessary since only one process option	Retained
	Access Restrictions	Deed Restrictions	<ul style="list-style-type: none"> Does not meet remediation goals alone No exposures during implementation Effectiveness dependent on continued future implementation 	<ul style="list-style-type: none"> Easily implemented Legal requirements 	Negligible cost	Retained
		Fencing	<ul style="list-style-type: none"> Does not meet remediation goals alone Minimal to low exposures during implementation 	<ul style="list-style-type: none"> Easily implemented Existing fence around Lots 201 and 203 No legal requirements 	Low capital, low O&M	Eliminated
Containment Actions	Extraction	Extraction Wells	<ul style="list-style-type: none"> Effective for collecting and/or containing a contaminated groundwater plume Potential exposures during implementation 	<ul style="list-style-type: none"> Easily installed Equipment readily available No permits required 	Moderate capital, low O&M	Retained
	Subsurface Drains	Interceptor Trenches	<ul style="list-style-type: none"> Effective for collecting and/or containing a contaminated groundwater plume Potential exposures during implementation Applicable for shallow groundwater plumes Slower recovery than extraction wells More effective for low permeability soils than extraction wells 	<ul style="list-style-type: none"> Equipment readily available Requires extensive excavation/trenching Requires more area than extraction wells 	Low to moderate capital, low O&M	Eliminated
	Discharge	Reinjection - Injection Wells	<ul style="list-style-type: none"> Effective for containing a contaminated groundwater plume if used in conjunction with extraction wells Potential exposures during implementation Injection wells effectiveness is dependent on site geology Wells tend to clog in time 	<ul style="list-style-type: none"> Easily installed Equipment readily available No permits required Require pilot test Significant maintenance 	Moderate capital, moderate O&M	Retained

TABLE 3-6 (Continued)

SUMMARY OF GROUNDWATER PROCESS OPTION EVALUATION
 FEASIBILITY STUDY CTO-0133
 MCB CAMP LEJEUNE, NORTH CAROLINA

General Response Action	Remedial Action Technology	Process Option	Evaluation			Evaluation Results
			Effectiveness	Implementability	Cost	
Collection/ Treatment Actions	Extraction	Extraction Wells	<ul style="list-style-type: none"> • Effective for collecting and/or containing a contaminated groundwater plume • Potential exposures during implementation 	<ul style="list-style-type: none"> • Easily implemented • Equipment readily available • No permits required 	Moderate capital, low O&M	Retained
	Subsurface Drains	Interceptor Trenches	<ul style="list-style-type: none"> • Effective for collecting and/or containing a contaminated groundwater plume • Potential exposures during implementation • Applicable for shallow groundwater plumes • Slower recovery than extraction wells • More effective for low permeability soils than extraction wells 	<ul style="list-style-type: none"> • Equipment readily available • Requires extensive excavation/trenching • Requires more area than extraction wells 	Low to moderate capital, low O&M	Eliminated
	Biological Treatment	Aerobic	<ul style="list-style-type: none"> • May be able to meet remediation goals • Potential exposures during implementation • Effectiveness dependent on biodegradability of contaminants 	<ul style="list-style-type: none"> • Equipment should be easily obtainable • Mobile units available • May require bench-scale testing 	Moderate capital, moderate O&M	Retained
		Anaerobic	<ul style="list-style-type: none"> • May be able to meet remediation goals • Potential exposures during implementation • Effectiveness dependent on anaerobic biodegradability of contaminants • Very slow process 	<ul style="list-style-type: none"> • Equipment should be easily obtainable • Mobile units available • May require bench-scale testing 	Moderate capital, moderate O&M	Retained

TABLE 3-6 (Continued)

SUMMARY OF GROUNDWATER PROCESS OPTION EVALUATION
 FEASIBILITY STUDY CTO-0133
 MCB CAMP LEJEUNE, NORTH CAROLINA

General Response Action	Remedial Action Technology	Process Option	Evaluation			Evaluation Results
			Effectiveness	Implementability	Cost	
Collection/ Treatment Actions (Cont)	Physical/ Chemical Treatment	Air Stripping	<ul style="list-style-type: none"> • Can potentially meet remediation goals for organics • Feasible for large volumes of moderate to low soluble VOC-contaminated water • Lower efficiency in cold weather • Proven and widely used technology • Potential exposures during implementation • May require pretreatment for metals 	<ul style="list-style-type: none"> • Equipment readily available • Many mobile units available • May require bench-scale testing • Off-gas and/or tower scale treatment may be required • May require air emissions permit 	Moderate capital, low to moderate O&M	Retained
		Steam Stripping	<ul style="list-style-type: none"> • Can potentially meet remediation goals • Feasible for large volumes of VOC-contaminated water • Lower efficiency in cold weather • May require pretreatment for metals and oils and grease • Typically used for less volatile or highly soluble compounds 	<ul style="list-style-type: none"> • Readily available, not as common as air stripping • May require air emissions permits • Off-gas and/or tower scale treatment may be required 	Moderate capital, moderate to high O&M	Eliminated
		Carbon Adsorption	<ul style="list-style-type: none"> • Can potentially meet remediation goals • Applicable to a wide variety of organics and inorganics • Can be used as a polishing step following air stripping • Proven and widely used technology 	<ul style="list-style-type: none"> • Equipment readily available • Many prefabricated mobile units available • May require bench-scale testing • Spent carbon must be properly handled 	Moderate capital (dependent on loading requirements), moderate to high O&M	Retained

TABLE 3-6 (Continued)

SUMMARY OF GROUNDWATER PROCESS OPTION EVALUATION
 FEASIBILITY STUDY CTO-0133
 MCB CAMP LEJEUNE, NORTH CAROLINA

General Response Action	Remedial Action Technology	Process Option	Evaluation			Evaluation Results
			Effectiveness	Implementability	Cost	
Collection/ Treatment Actions (Cont)	Physical/ Chemical Treatment (Cont)	Ion Exchange	<ul style="list-style-type: none"> • May not meet all remediation goals • Effective and reliable; proper pretreatment required • Typically used as a polishing step for removal of selected dissolved metals • Insensitive to variations in flow rates • Pretreatment for oil and grease required 	<ul style="list-style-type: none"> • Full-scale industrial use for recovery of valuable metals • Equipment is widely available • Regeneration solutions are generally readily available • Bench-testing required • Residuals include waste solutions and spent resins 	Moderate to high capital, moderate to high O&M	Eliminated
		Chemical Reduction	<ul style="list-style-type: none"> • May not meet all remediation goals • Well studied and understood reaction • It is not a selective process • Limited to a few selected metals (chromium, mercury, lead) • Typically followed by precipitation • If complex wastewater - oxidized chemicals may be reduced to more toxic forms 	<ul style="list-style-type: none"> • Simple and readily available equipment • The continuous process configuration is easily automated • Easily implemented 	Low to moderate capital, moderate to high O&M	Eliminated
		Chemical Oxidation	<ul style="list-style-type: none"> • May not meet all remediation goals • Reliable and proven on industrial wastewaters for metals (manganese, iron) treatment. Can be used alone or in conjunction with precipitation 	<ul style="list-style-type: none"> • Well-demonstrated at hazardous waste sites in pilot- and full-scale • Readily available, conventional equipment required • Bench scale testing normally required 	Low to moderate capital, moderate to high O&M	Eliminated
		Neutralization	<ul style="list-style-type: none"> • Will not meet all remediation goals • Can be used in a treatment train for pH adjustment 	<ul style="list-style-type: none"> • Widely used and well demonstrated • Simple and readily available equipment/materials • Bench-scale studies may be required 	Low capital, low to moderate O&M	Retained
		Precipitation	<ul style="list-style-type: none"> • May meet inorganic remediation goals • Effective, reliable, permanent, and conventional technology • Typically used for removal of heavy metals • Followed by solids-separation method • Generates sludge which can be voluminous, difficult to dewater, and may require treatment 	<ul style="list-style-type: none"> • Widely used and well demonstrated • Equipment is basic and easily designed • Compact, single units that are deliverable to the site • Requires bench- or pilot-scale tests 	Low capital, moderate O&M	Retained

TABLE 3-6 (Continued)

SUMMARY OF GROUNDWATER PROCESS OPTION EVALUATION
 FEASIBILITY STUDY CTO-0133
 MCB CAMP LEJEUNE, NORTH CAROLINA

General Response Action	Remedial Action Technology	Process Option	Evaluation			Evaluation Results
			Effectiveness	Implementability	Cost	
Collection/ Treatment Actions (Cont)	Physical/ Chemical Treatment (Cont)	Filtration	<ul style="list-style-type: none"> • Will not meet inorganic remediation goals alone • Conventional, proven method of removing suspended solids from wastewater • Does not remove other contaminants • Pretreatment for oil and grease required • Generates a sludge which requires proper handling 	<ul style="list-style-type: none"> • Equipment is relatively simple to install and no chemicals are required • Pilot study is required • Package units available 	Low capital, low O&M	Retained
		Flocculation	<ul style="list-style-type: none"> • May not meet inorganic remediation goals • Well established technology • Applicable to any aqueous waste stream where particles must be agglomerated into larger more settleable particles prior to other types of treatment • Performance depends on the variability of the composition of the waste being treated 	<ul style="list-style-type: none"> • Equipment is readily available and easy to operate • Can be easily integrated into more complex treatment systems 	Low capital, moderate O&M	Retained
		Sedimentation	<ul style="list-style-type: none"> • Will not meet inorganic remediation goals alone • Effective for removing suspended solids and precipitated materials from wastewater • Performance depends on density and particle size of the solids; effective charge on the suspended particles; types of chemicals used in pretreatment; surface loading; upflow rate; and rejection time • Feasible for large volumes of water to be treated 	<ul style="list-style-type: none"> • Sedimentation tanks demonstrated and proven successful at hazardous waste sites • Effluent streams include the effluent water, scum, and settled solids 	Moderate capital, moderate O&M	Eliminated

SUMMARY OF GROUNDWATER PROCESS OPTION EVALUATION
 FEASIBILITY STUDY CTO-0133
 MCB CAMP LEJEUNE, NORTH CAROLINA

General Response Action	Remedial Action Technology	Process Option	Evaluation			Evaluation Results
			Effectiveness	Implementability	Cost	
Collection/ Treatment Actions (Cont)	Thermal Treatment	Incineration	<ul style="list-style-type: none"> • May meet remediation goals • Capable of burning waste in any physical form • Susceptible to thermal shock • Low thermal efficiency • Potential exposures during operation 	<ul style="list-style-type: none"> • Commercially available and widely used • Requires air emission controls and extensive maintenance • Skilled workers required • Generates exhaust gases and ash residue 	High capital, moderate to high O&M	Retained
		Molten Salt	<ul style="list-style-type: none"> • May meet remediation goals • Applicable for the destruction of liquids and solids • Appears to be sensitive to materials containing high ash content or high chlorine content • Molten salt produced may be corrosive • Potential exposures during operation 	<ul style="list-style-type: none"> • Emerging technology • Developmental, pilot-scale units available • Requires frequent bed replacement 	High capital, moderate to high O&M	Eliminated
	Off-Site Treatment	POTW	<ul style="list-style-type: none"> • Effectiveness and reliability require pilot test to determine 	<ul style="list-style-type: none"> • Existing POTW may need upgraded • Readily implementable if POTW will grant permission; otherwise may not be feasible • Permit required 	Lot capital, moderate O&M	Eliminated
		RCRA Facility	<ul style="list-style-type: none"> • Effective and reliable treatment • Transportation required 	<ul style="list-style-type: none"> • Dependent on availability of and distance to nearest RCRA facility 	Moderate capital, moderate O&M	Retained
		Sewage Treatment Plant	<ul style="list-style-type: none"> • Effectiveness and reliability require pilot test to determine 	<ul style="list-style-type: none"> • Readily implementable if STP will accept waste; otherwise may not be feasible • Modifications to permits may be required 	Low capital, low O&M	Eliminated
	In Situ Treatment	Air Sparging	<ul style="list-style-type: none"> • Not a proven technology since the concept is new (emerging technology) • Highly dependent on geology • Monitoring via wells may not be effective • Generally considered a shallow aquifer technology only 	<ul style="list-style-type: none"> • Emerging technology • Equipment and materials should be readily available • Treatability studies required • May reduce the remediation time as compared to bioremediation alone 	Not documented - but should be moderate capital, low to moderate O&M	Eliminated

TABLE 3-6 (Continued)

SUMMARY OF GROUNDWATER PROCESS OPTION EVALUATION
FEASIBILITY STUDY CTO-0133
MCB CAMP LEJEUNE, NORTH CAROLINA

General Response Action	Remedial Action Technology	Process Option	Evaluation			Evaluation Results
			Effectiveness	Implementability	Cost	
Collection/Treatment Actions (Cont)	On-Site Discharge	Surface Water	<ul style="list-style-type: none"> Effective and reliable discharge method 	<ul style="list-style-type: none"> May require impact studies to assess affects to environment NPDES permit required 	Low to moderate capital, low O&M	Retained
		Reinjection - Injection Wells	<ul style="list-style-type: none"> Injection wells effectiveness is highly dependent on site geology Wells tend to clog in time Potential exposures during implementation 	<ul style="list-style-type: none"> Easily installed Equipment readily available No permits required Require pilot test Significant maintenance 	Moderate capital, moderate O&M	Eliminated
	Off-Site Discharge	POTW	<ul style="list-style-type: none"> Effective and reliable discharge method 	<ul style="list-style-type: none"> Discharge permits required Acceptance by a local POTW may be difficult to obtain 	Low capital, moderate O&M	Eliminated
		Pipeline to River	<ul style="list-style-type: none"> Effective and reliable discharge method 	<ul style="list-style-type: none"> Discharge permits required Distance to New River from operable unit may make this option difficult to implement 	Moderate to high capital, low O&M	Retained
		Sewage Treatment Plant	<ul style="list-style-type: none"> Effective and reliable discharge method 	<ul style="list-style-type: none"> Discharge permit may need modified Capacity of the Hadnot Point STP may not be able to accept the flow 	Low capital, low O&M	Eliminated
		Drinking Water Treatment Plant	<ul style="list-style-type: none"> Effective discharge option Innovative approach Reuse of water 	<ul style="list-style-type: none"> Drinking water plant's discharge. Permit may need modified May require groundwater treatment system to be modified May be difficult to gain acceptance 	Low capital, low O&M	Retained
		Deep Well Injection	<ul style="list-style-type: none"> Injection wells effectiveness is highly dependent on site geology Wells may clog in time 	<ul style="list-style-type: none"> Discharge permit required Injection wells must be installed 	Moderate Capital, moderate O&M	Retained

TABLE 3-7

**SUMMARY OF SOIL PROCESS OPTION EVALUATIONS
FEASIBILITY STUDY CTO-0133
MCB CAMP LEJEUNE, NORTH CAROLINA**

General Response Action	Remedial Action Technology	Process Option	Evaluation			Evaluation Results
			Effectiveness	Implementability	Cost	
No Action	No Action	Not Applicable	Evaluation not necessary since only one process option.	Evaluation not necessary since only one process option.	Evaluation not necessary since only one process option.	Retained
Institutional Controls	Monitoring	Monitoring	Evaluation not necessary since only one process option.	Evaluation not necessary since only one process option.	Evaluation not necessary since only one process option.	Retained
	Access Restrictions	Deed Restrictions	<ul style="list-style-type: none"> Does not meet remediation goals alone No exposures during implementation Effectiveness dependent on continued future implementation 	<ul style="list-style-type: none"> Easily implemented Legal requirements 	Negligible Cost	Retained
		Fencing	<ul style="list-style-type: none"> Does not meet remediation goals alone Minimal to low exposures during implementation 	<ul style="list-style-type: none"> Easily implemented Existing fence around Lots 201 and 203 No legal requirements 	Low Capital, Low O&M	Retained
Containment Action	Capping	Clay/Soil Cap	<ul style="list-style-type: none"> Does not eliminate contamination but effectively seals off surface Reliable capping technology 	<ul style="list-style-type: none"> Easily implemented Materials, workers, equipment easily obtainable Restrictions on future land use required 	Low Capital, Moderate O&M	Eliminated
		Asphalt/Concrete Cap	<ul style="list-style-type: none"> Does not eliminate contamination, but is an effective sealant Reliable capping technology, but it is susceptible to weathering and cracking 	<ul style="list-style-type: none"> Easily implemented Materials, equipment, workers easily obtainable Restrictions on future land use required 	Low Capital; Moderate O&M	Eliminated
		Soil Cover	<ul style="list-style-type: none"> Does not eliminate contamination, but is an effective direct contact barrier Reliable technology for a contact barrier, but it is susceptible to cracking 	<ul style="list-style-type: none"> Easily implemented Materials, equipment, workers easily obtainable Restrictions on future land use required 	Low Capital; Moderate O&M	Retained
		Multilayered Cap	<ul style="list-style-type: none"> Does not eliminate contamination, but is an effective sealant Reliable capping technology 	<ul style="list-style-type: none"> Easily implemented Materials, equipment, workers easily obtainable Restrictions on future land use required 	Moderate Capital; Moderate O&M	Retained

TABLE 3-7 (Continued)

SUMMARY OF SOIL PROCESS OPTION EVALUATIONS
 FEASIBILITY STUDY CTO-0133
 MCB CAMP LEJEUNE, NORTH CAROLINA

General Response Action	Remedial Action Technology	Process Option	Evaluation			Evaluation Results
			Effectiveness	Implementability	Cost	
Containment Action (Cont.)	Surface Controls	Grading	<ul style="list-style-type: none"> Does not meet remediation goals, but is a proven method for controlling infiltration and erosion 	<ul style="list-style-type: none"> Easily implemented Equipment and workers easily obtainable 	Low Capital; Low O&M	Retained
		Revegetation	<ul style="list-style-type: none"> Does not meet remediation goals, but is an effective method for stabilizing the surface of a waste site Minimal impacts during construction 	<ul style="list-style-type: none"> Easily implemented Materials, equipment, workers easily obtainable 	Low Capital; Low O&M	Retained
Excavation/ Treatment Actions	Excavation	Soil Excavation	<ul style="list-style-type: none"> Can remove soils with contamination above the remediation goals High potential impacts during implementation Effective technology 	<ul style="list-style-type: none"> Easily implemented Equipment and workers easily obtainable 	Low Capital, No O&M	Retained
	Biological Treatment	Land Treatment	<ul style="list-style-type: none"> May be able to meet remediation goals Potential exposures during excavation, installation, and operation Effective for biodegradable and volatile compounds 	<ul style="list-style-type: none"> Requires a lot of space (Lot 203) Requires treatability study 	Moderate Capital, Moderate O&M	Retained for VOC/SVOC-contaminated soils
		Composting	<ul style="list-style-type: none"> May be able to meet remediation goals Potential exposures during excavation, installation, and operation Effective for biodegradable and volatile compounds 	<ul style="list-style-type: none"> Requires less space than land treatment Takes longer than land treatment Requires treatability study 	Moderate Capital, Moderate O&M	Eliminated
	Physical/ Chemical Treatment	Solidification/Stabilization	<ul style="list-style-type: none"> Reduces migration potential of contaminants (primarily inorganics) Contaminants still present in waste Long term reliability is uncertain 	<ul style="list-style-type: none"> Skilled workers required May require bench scale testing Complex design and evaluation required 	High Capital; Moderate O&M	Eliminated

TABLE 3-7 (Continued)

SUMMARY OF SOIL PROCESS OPTION EVALUATIONS
 FEASIBILITY STUDY CTO-0133
 MCB CAMP LEJEUNE, NORTH CAROLINA

General Response Action	Remedial Action Technology	Process Option	Evaluation			Evaluation Results
			Effectiveness	Implementability	Cost	
Excavation/ Treatment Actions	Physical/ Chemical Treatment (Cont.)	Soil Washing	<ul style="list-style-type: none"> • May be able to meet remediation goals • Potential exposures during excavation, installation, and operation • Effectiveness is highly dependent upon site-specific conditions • Less effective with complex mixtures of waste types • Limited to granular soils 	<ul style="list-style-type: none"> • Residuals are generated that require treatment • Skilled workers required • Equipment should be easily obtainable 	Moderate Capital; Moderate O&M	Eliminated
		Chemical Dechlorination (KPEG)	<ul style="list-style-type: none"> • Achieves performance levels that are considered equivalent to incineration • Treatment efficiency varies with Aroclor type • Products of treatment reaction are non-toxic, non-mutagenic, and non-bioaccumulative • Treated waste may still require chemical waste landfill disposal 	<ul style="list-style-type: none"> • Treatability study may be required • Skilled workers required • May require transportation • Cost varies with reagent recyclability 	High Capital; Low O&M	Retained for PCB-contaminated soils
	Thermal Treatment	Incineration	<ul style="list-style-type: none"> • Should be capable of meeting remediation goals • Capable of burning waste in any physical form • Potential exposures during operation and monitoring 	<ul style="list-style-type: none"> • Mobile units commercially available and widely used • Requires air emission controls and extensive maintenance • Skilled workers required • Generates residuals: exhaust gas and ash 	High Capital; Low O&M	Retained
		Molten Salt	<ul style="list-style-type: none"> • May be able to meet remediation goals • Sensitive to materials containing high ash content or high chlorine content • Molten salt produced may be corrosive 	<ul style="list-style-type: none"> • Innovative technology • Departmental stage; pilot-scale units available • Requires frequent bed replacement 	High Capital; High O&M	Eliminated

TABLE 3-7 (Continued)

SUMMARY OF SOIL PROCESS OPTION EVALUATIONS
 FEASIBILITY STUDY CTO-0133
 MCB CAMP LEJEUNE, NORTH CAROLINA

General Response Action	Remedial Action Technology	Process Option	Evaluation			Evaluation Results
			Effectiveness	Implementability	Cost	
Excavation/ Treatment Actions (Cont.)	Thermal Treatment (Cont.)	Infrared Incineration	<ul style="list-style-type: none"> • May be able to meet remediation goals • Effectively treated halogenated and nonhalogenated organics • Soils and sludges must be greater than 22 percent solids or must be dewatered • Nonuniform feed size requires pretreatment prior to entering unit • Heavy metals are not fixed in ash 	<ul style="list-style-type: none"> • Generated residuals include flue gases, ash, scrubber effluents • Mobile units are available 	High Capital; High O&M	Eliminated
		Pyrolysis	<ul style="list-style-type: none"> • May be able to meet remediation goals • Not effective for wastes with nitrogen, sulfur, or sodium contents • Requires homogeneous waste input 	<ul style="list-style-type: none"> • Mobile units are commercially available 	High Capital; High O&M	Eliminated
	In Situ Treatment	Biodegradation	<ul style="list-style-type: none"> • More suited to non-PCB organic contaminants and may not meet PCB remediation goals • Treatment can be inconsistent due to variations in biological activity 	<ul style="list-style-type: none"> • PCBs may be toxic to microorganisms • Requires treatability studies • Dependent upon site hydrogeology 	Moderate to High Capital; Moderate to High O&M	Eliminated
		Volatilization	<ul style="list-style-type: none"> • Highly dependent on site geology • Applicable to VOCs and selected SVOCs only • Not effective for PCBs 	<ul style="list-style-type: none"> • Equipment readily available • Easy to install (vapor extraction wells) • Dependent upon site geology • Pilot studies may be required 	Moderate Capital; Low to Moderate O&M	Retained for VOC-contaminated soils
		Soil Flushing	<ul style="list-style-type: none"> • More suited to non-PCB organic contaminants and may not meet PCB remediation goals • Difficult to achieve uniform cleaning due to soil inconsistency • Treatment of washing solvent required 	<ul style="list-style-type: none"> • Requires treatability studies • Dependent upon site hydrogeology • System must be integrated with a soluble plume containment system 	Moderate to High Capital; Moderate to High O&M	Eliminated

TABLE 3-7 (Continued)

SUMMARY OF SOIL PROCESS OPTION EVALUATIONS
 FEASIBILITY STUDY CTO-0133
 MCB CAMP LEJEUNE, NORTH CAROLINA

General Response Action	Remedial Action Technology	Process Option	Evaluation			Evaluation Results
			Effectiveness	Implementability	Cost	
Excavation/ Treatment Actions (cont)	In Situ Treatment (Cont.)	Vitrification	<ul style="list-style-type: none"> Retention of volatile metals in melt is reduced as surface is approached Groundwater should not be present in soils to be treated Feasibility tests must be performed to determine soil's conductance 	<ul style="list-style-type: none"> Buried metals may result in shorting of electrodes Loosely packed rubbish may result in underground fires 	High Capital; Minimal O&M	Eliminated
	Off-Site Treatment/ Disposal	RCRA Facility	<ul style="list-style-type: none"> Will meet remediation goals Potential exposure during excavation and transportation activities 	<ul style="list-style-type: none"> Dependent upon facility availability Requires transportation Adequate testing required 	High Capital; Minimal O&M	Retained
		Landfill	<ul style="list-style-type: none"> Will meet remediation goals at the site but does not destroy the contaminants "Cradle to Grave" problem Potential exposures during excavation and transportation activities 	<ul style="list-style-type: none"> Dependent upon landfill capacity Requires transportation Adequate testing required 	Moderate to High Capital; Minimal O&M for hazardous waste landfill Low to Moderate Capital; Minimal O&M for nonhazardous waste landfill	Retained

TABLE 3-8

FINAL SET OF POTENTIAL REMEDIAL ACTION TECHNOLOGIES
AND PROCESS OPTIONS
FEASIBILITY STUDY CTO-0133
MCB CAMP LEJEUNE, NORTH CAROLINA

Media	General Response Action	Remedial Action Technology	Process Option
Groundwater	No Action	No Action	Not Applicable
	Institutional Controls	Monitoring	Groundwater Monitoring
		Ordinances	Aquifer-Use Restrictions
		Access Restrictions	Deed Restrictions
	Containment Actions	Extraction	Extraction Wells
		Discharge	Reinjection - Injection Wells
	Collection/Treatment Actions	Extraction	Extraction Wells
		Biological Treatment	Aerobic
			Anaerobic
		Physical/Chemical Treatment	Air Stripping
			Carbon Adsorption
			Neutralization
			Precipitation
			Filtration
		Flocculation	
		Thermal Treatment	Incineration
	Off-Site Treatment	RCRA Facility	
On-Site Discharge	Surface Water (Wallace Creek)		
Off-Site Discharge	Pipeline to New River		
	Drinking Water Plant		
Deep Well Injection			
Soil	No Action	No Action	Not Applicable
	Institutional Controls	Monitoring	Monitoring
		Access Restrictions	Deed Restrictions
			Fencing
	Containment Actions	Capping	Soil Cover
		Surface Controls	Multilayered Cap
			Grading
			Revegetation
	Excavation/Treatment Actions	Soil Excavation	
		Excavation	Land Treatment
		Biological Treatment	Chemical Dechlorination (KPEG)
		Physical/Chemical Treatment	Incineration
		Thermal Treatment	Volatilization
		In Situ Treatment	RCRA Facility
Off-Site Treatment/Disposal	Landfill		

4.0 DEVELOPMENT AND SCREENING OF ALTERNATIVES

In this section, general response actions and the process options chosen to represent the various technology types applicable for OU No. 2 will be combined to form remedial action alternatives (RAAs) for the operable unit. Following development, each alternative may be evaluated against the short-term and long-term aspects of three criteria: effectiveness, implementability, and cost (i.e., the preliminary screening). The RAAs with the most favorable composite evaluation of all criteria will be retained for further consideration during the detailed evaluation presented in Section 5.0. Note that the preliminary screening at this step of the FS is optional. It will only be conducted if too many alternatives are initially developed.

4.1 Development of Alternatives

The general response actions and process options chosen to represent the various applicable technologies identified on Table 3-8 have been combined into separate RAAs potentially applicable for either the contaminated groundwater, or the soil AOCs within the operable unit. The categorization of the RAAs into separate media-specific RAAs will allow for the independent evaluation of various alternatives for each affected medium. A completely developed RAA for OU No. 2 will consist of an RAA from both media of concern.

Table 4-1 presents the set of RAAs developed for remediating the contaminated groundwater within the operable unit. The components of each RAA (i.e., technology type and process option) and the area or volume included under each RAA is presented in the table. Five RAAs have been identified for groundwater ranging from no action to groundwater extraction and treatment. Table 4-2 presents the set of RAAs developed for remediating the soil AOCs within the operable unit. Seven RAAs have been identified for the contaminated soil ranging from no action to complete removal and off-site treatment/disposal.

A description of all the RAAs with respect to each media of concern is presented below.

TABLE 4-1

POTENTIAL SET OF GROUNDWATER REMEDIAL ACTION ALTERNATIVES
 FEASIBILITY STUDY CTO-0133
 MCB CAMP LEJEUNE, NORTH CAROLINA

Technology Type	Process Option	Area or Volume	1	2	3	4	5
			No Action	Limited Action	Containment	Intensive Groundwater Extraction and Treatment	Groundwater Extraction and Treatment
Monitoring	Groundwater Monitoring	21 Existing monitoring wells		X	X	X	X
		6 Extraction wells placed for containment or treatment			X		X
		2 Extraction wells placed for treatment				X	X
Ordinances	Aquifer-Use Restrictions and Deed Restrictions	Supply Wells 633, 635, 636, 637 and 651		X	X	X	X
Extraction	Extraction Wells	6 Extraction wells placed for containment or treatment			X		X
		2 Extraction wells placed for treatment				X	X
Treatment	Treatment Train Consisting of Air Stripping, Carbon Adsorption, and Metals Removal	Extracted groundwater			X	X	X
Discharge	Surface Water (Wallace Creek)	Treated groundwater			X	X	X

TABLE 4-2

POTENTIAL SET OF SOIL REMEDIAL ACTION ALTERNATIVES
 FEASIBILITY STUDY CTO-0133
 MCB CAMP LEJEUNE, NORTH CAROLINA

Technology Type	Process Option	Area or Volume	1	2	3	4	5	6	7
			No Action	Capping	On-Site Treatment	Capping and On-Site Treatment (All AOCs)(1)	Off-Site Treatment/ Disposal	Capping and On-Site Treatment (Limited AOCs)	On-Site Treatment and Off-Site Disposal
Monitoring	Monitoring	Existing monitoring wells		X		X			X
Access Restrictions	Deed Restrictions	Site 6 and Site 82		X		X		X	
	Fencing	Capped area or treatment area		X	X	X		X	X
Capping	Multilayered Cap	Soil from all soil AOCs		X					
		Soil AOCs 3, 4, and 6				X			
		Soil AOCs 4 and 5 only						X	
Surface Controls	Grading	All disturbed areas		X	X	X	X	X	X
	Revegetation	All disturbed areas		X	X	X	X	X	X
Excavation	Soil Excavation	All soil AOCs		X	X		X		
		Soil AOCs 1, 2, and 5				X			
		Soil AOCs 4 and 5 only						X	
		Soil AOCs 2 through 6							X
On-Site Treatment	A. Land Treatment B. In situ Volatilization C. Chemical Dechlorination D. Incineration (Mobile)	Soil from all soil AOCs			X				
		Soil AOCs 1 and 5				X			
		Soil AOC1 only						X	X
Off-Site Treatment/ Disposal	Permitted Facility	All Soil AOCs					X		
		Soil AOCs 2 through 6							X

(1) AOC = Area of Concern

4-3

4.1.1 Groundwater RAAs

4.1.1.1 Groundwater RAA No. 1: No Action

Under the No Action Alternative, no remedial actions will be performed to reduce the toxicity, mobility, or volume of the contaminants in the groundwater at OU No. 2. Under this alternative, the contaminants identified in the shallow and deep portions of the aquifer will remain, which will result in the potential for further migration of the contaminated plume. Aquifer restoration may result through natural processes such as biological degradation, attenuation, and dispersion.

The no action alternative is required by the NCP to provide a baseline for comparison with other RAAs. Since contaminants will remain at the site under this alternative, the USEPA is required by the NCP [40 CFR 300.515(e)(ii)] to review the effects of this alternative no less often than every five years.

4.1.1.2 Groundwater RAA No. 2: Limited Action

Under Groundwater RAA No. 2, no remedial actions will be performed to reduce the toxicity, mobility, or volume of contaminants in the groundwater at OU No. 2. The only actions included under this RAA are institutional controls (i.e., monitoring, ordinances, and deed restrictions). Aquifer restoration may occur through natural processes such as biological degradation, attenuation, and dispersion.

RAA No. 2 will include the following three institutional controls: long-term groundwater monitoring, aquifer-use restrictions, and deed restrictions. The RAA will include semiannually sampling and analysis of 21 existing wells and 3 supply wells at the operable unit. As shown on Figure 4-1, the wells to be sampled are located near each of the contaminated plume areas. As listed below, the wells to be monitored include nine deep monitoring wells, twelve shallow monitoring wells, and three operational supply wells.

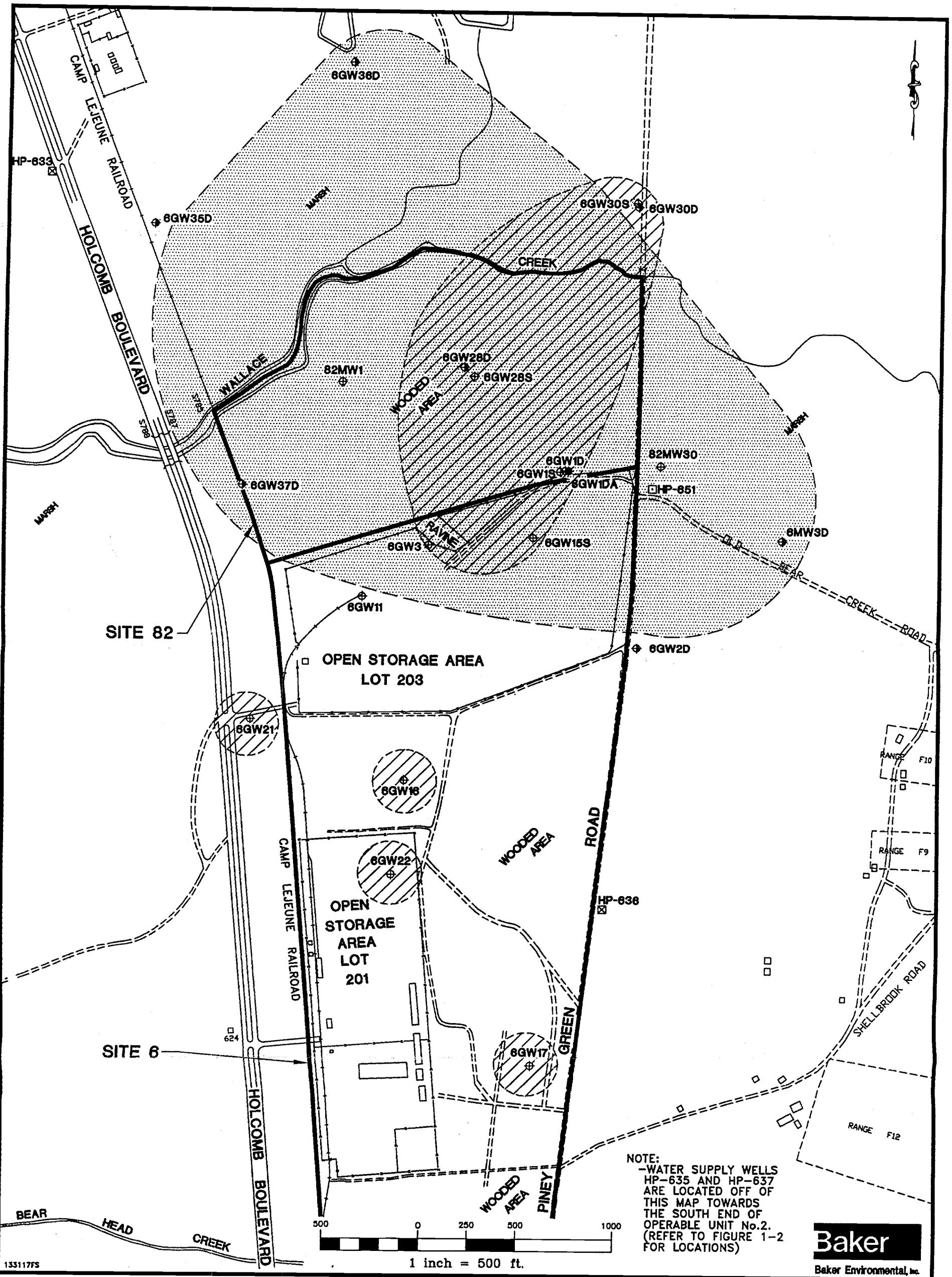

4-5

LEGEND	
8GW18 ⊕	SHALLOW MONITORING WELL INCLUDED IN MONITORING PROGRAM
8GW1D ⊕	DEEP MONITORING WELL INCLUDED IN MONITORING PROGRAM
HP-636 ⊠	WATER SUPPLY WELL (TO BE MONITORED)
HP-651 ⊠	WATER SUPPLY WELL (CLOSED)
⊕	APPROXIMATE AREA OF GROUNDWATER (DEEPER PORTION) CONTAMINATION EXCEEDING REMEDIATION GOALS
⊕	APPROXIMATE AREA OF GROUNDWATER (SHALLOW PORTION) CONTAMINATION EXCEEDING REMEDIATION GOALS

FIGURE 4-1
 GROUNDWATER RAA No.2: LIMITED ACTION
 FEASIBILITY STUDY CTO-0133
 MARINE CORPS BASE, CAMP LEJEUNE
 NORTH CAROLINA

SOURCE: LANTDIV, FEBRUARY 1992



01483CC04Z

<u>Deep Wells</u>	<u>Shallow Wells</u>	<u>Supply Wells</u>
6GW1D	6GW1S	HP-633
GGW1DA	6GW3	HP-635
6GW2D	6GW11	HP-636
6MW3D	6GW15S	
6GW28D	6GW16	
6GW30D	6GW17	
6GW35D	6GW21	
6GW36D	6GW22	
6GW37D	6GW28S	
	6GW30S	
	82MW1	
	82MW30	

Additional wells may be added to the monitoring program, if necessary. Samples will be collected on a semiannual basis for 30 years and analyzed for TCL volatiles. Please note that the 30-year duration is based on EPA guidance for evaluation in an FS.

Aquifer-use restrictions will be placed on the local supply wells. Supply Wells 637 and 651 are currently inactive. Under Alternative 2, these two wells will remain inactive. In addition, Supply Wells 633, 635, and 636 will be monitored semiannually. The locations of the Supply Wells 633, 636 and 651 are shown on Figure 4-1. The other two supply wells (635 and 637) are not on Figure 4-1 because they are located further south than the area shown. Refer to Figures 1-2 or 2-2 for the location of these two wells.

Deed restrictions will be placed restricting the installation of any new wells within the vicinity of OU No. 2.

In the event that the monitoring program indicates that the groundwater conditions are deteriorating, other actions will be taken. In addition, since contaminants will remain at the site under this alternative, the USEPA is required by the NCP [40 CFR 300.515(e)(ii)] to review the effects of this alternative no less often than every five years.

4.1.1.3 Groundwater RAA No. 3: Containment

In general, RAA No. 3: Containment includes the containment of the contaminated plumes (both shallow and deep portions) via extraction and treatment. In addition, this RAA includes the same institutional controls as Groundwater RAA No. 2 (Limited Action). The objective of this RAA is to reduce or eliminate the potential for further migration of the existing

groundwater contaminant plumes at the operable unit. The major components of Groundwater RAA No. 3 are displayed on Figure 4-2 and described below.

Containment

Under this RAA, the contaminated groundwater plume originating from Site 82 will be contained to eliminate further contaminant migration via a network of extraction wells placed along the downgradient (and upgradient) boundaries of the shallow and deep plumes. Extracted groundwater will be treated on site via one of a combination of applicable treatment options (treatment train), and then discharged to Wallace Creek. Details of the extraction system and treatment system are discussed below.

Groundwater Extraction System - Under this RAA, groundwater in both the shallow and deep portions of the aquifer near the edges of the existing contaminated plumes will be withdrawn through a network of extraction wells. A typical extraction well is shown on Figure 4-3. Preliminary aquifer characteristics used to estimate the number of extraction wells needed and the estimated groundwater extraction flow rate have been based on EPA's Wellhead Protection Area computer program, version 2.0 (Geophex, 1991). The model was based on an assumed pumping rate of 300 gallons per minute (gpm), a transmissivity of 15,000 square feet per day, and an effective porosity of 0.25. Based on these assumptions, the model estimated a 10-year radius of influence to have the dimensions of 2,100 feet long by 1,700 feet wide for an approximate area of 65 acres.

For this FS and based on the above-mentioned factors, RAA No. 3 will include the installation of six 6-inch extraction wells pumping at a rate of 150 gpm and installed at a depth of approximately 110 feet. This RAA also includes the installation of six extraction wells pumping at a rate of 5 gpm and installed at a depth of 35 feet. The proposed locations of the extraction wells are shown on Figure 4-2. The locations for the wells were based on several factors including estimated radius of influence dimensions; spacings of overlapping cones of depressions; accessibility; and location with respect to Wallace Creek. The existing marsh area around Wallace Creek was a primary factor in determining the placement of these initial extraction wells. A radius of influence of 150 feet was used for placing the shallow extraction wells. This radius of influence and the estimated pumping rate were based on information obtained from pumping tests conducted at nearby sites within MCB Camp Lejeune. Note that no extraction wells are located near the small shallow groundwater plumes west and south of Storage Lot 203. Additional extraction

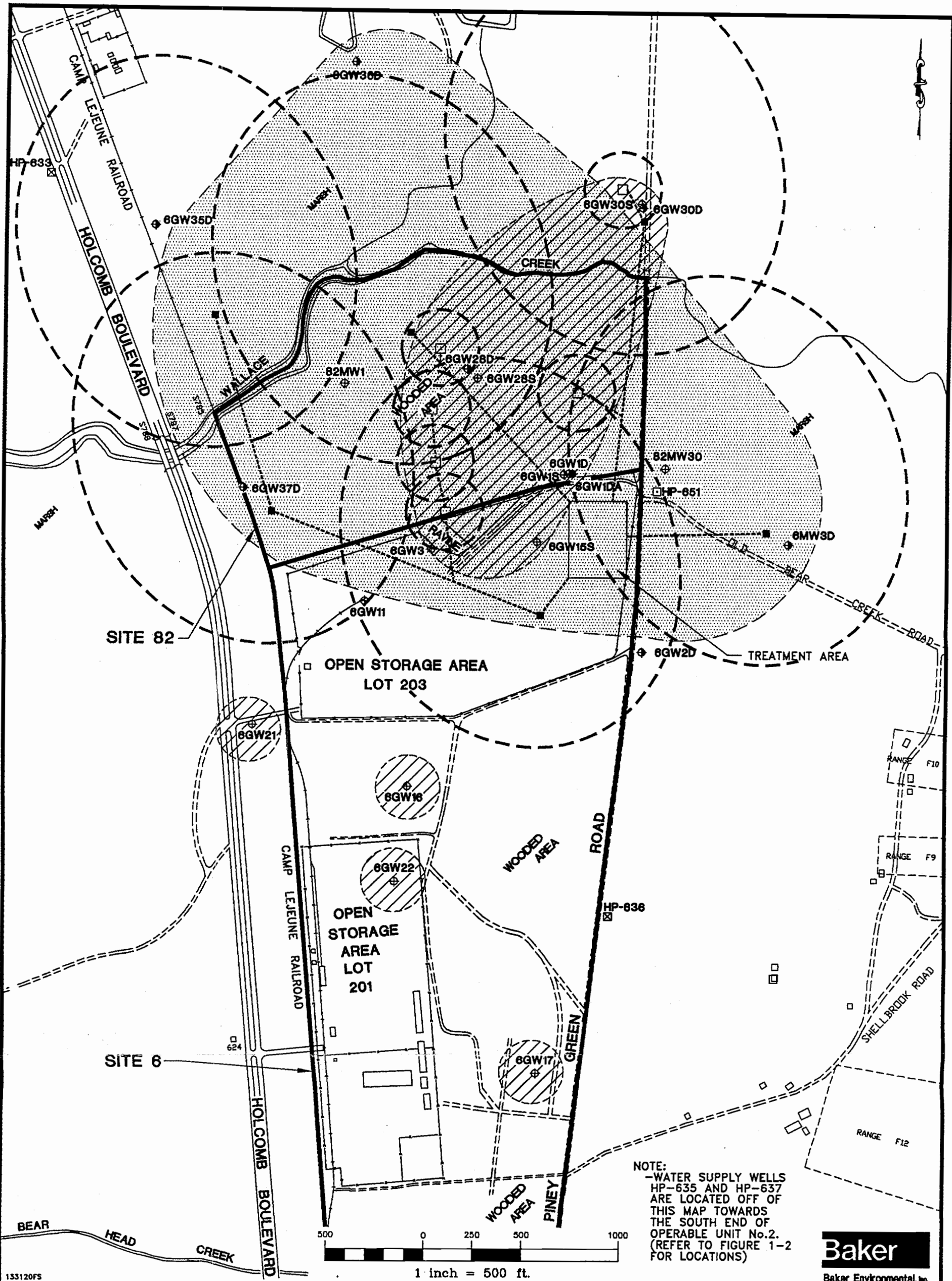

4-8

133120FS

LEGEND	
— PIPING PROPOSED DEEP EXTRACTION WELLS	● APPROXIMATE AREA OF GROUNDWATER (DEEPER PORTION) CONTAMINATION EXCEEDING REMEDIATION GOALS
— PIPING PROPOSED SHALLOW EXTRACTION WELLS	○ APPROXIMATE AREA OF GROUNDWATER (SHALLOW PORTION) CONTAMINATION EXCEEDING REMEDIATION GOALS
⊕ 6GW18 SHALLOW MONITORING WELL INCLUDED IN MONITORING PROGRAM	⊖ ESTIMATED ZONE OF CAPTURE
⊕ 6GW1D DEEP MONITORING WELL INCLUDED IN MONITORING PROGRAM	
⊕ HP-636 WATER SUPPLY WELL (TO BE MONITORED)	
⊕ HP-651 WATER SUPPLY WELL (CLOSED)	
□ SOURCE: LANTDIV, FEBRUARY 1992	

FIGURE 4-2
 GROUNDWATER RAA No.3:CONTAINMENT
 FEASIBILITY STUDY CTO-0133
 MARINE CORPS BASE, CAMP LEJEUNE
 NORTH CAROLINA

01483 CC05Z

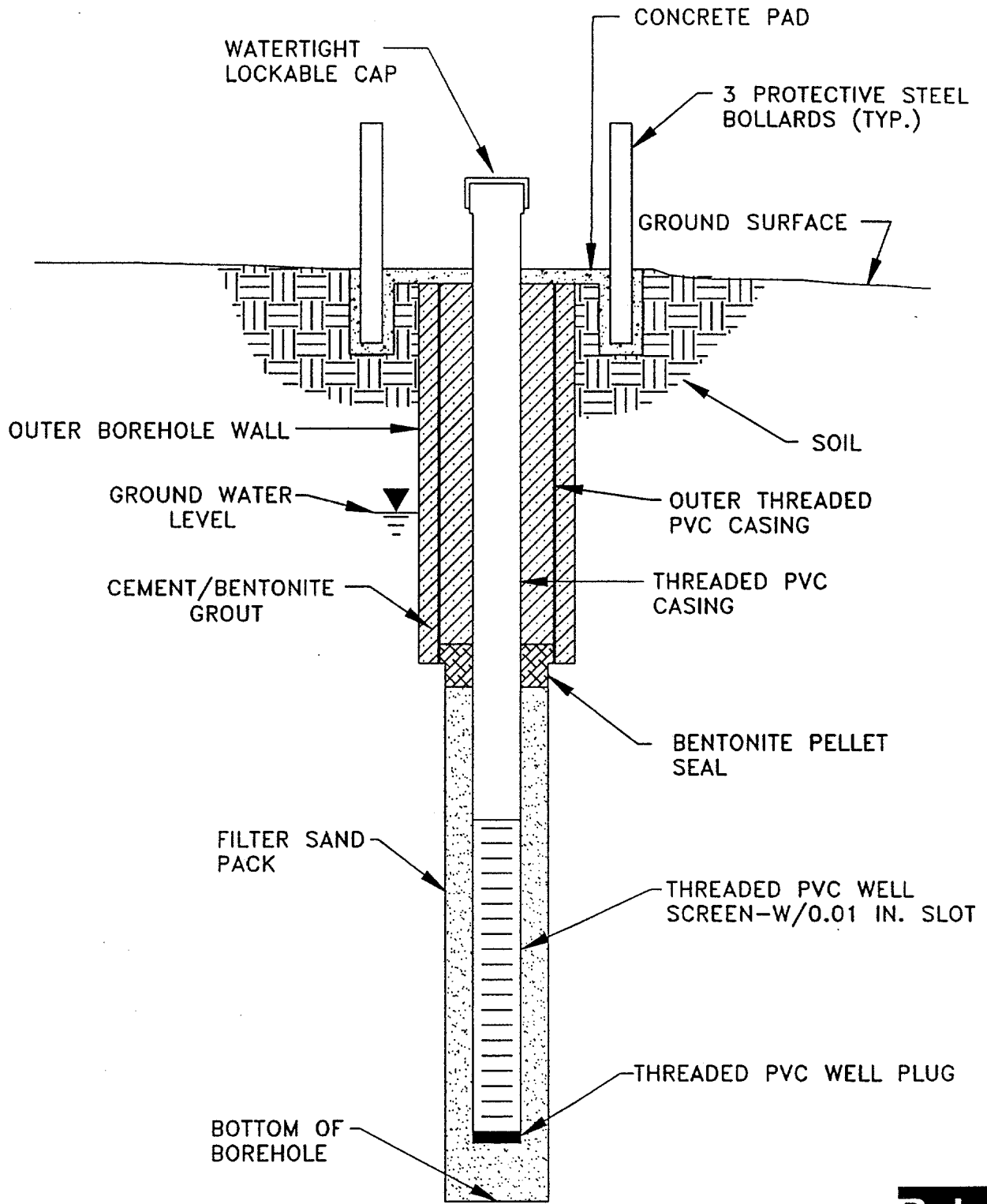

N.T.S.



FIGURE 4-3
TYPICAL DEEP GROUNDWATER
EXTRACTION WELL CONSTRUCTION DIAGRAM
FEASIBILITY STUDY CTO-0133

MARINE CORPS BASE, CAMP LEJEUNE
NORTH CAROLINA

wells will be added to the system if groundwater monitoring indicates that the groundwater is significantly deteriorating in other areas of the site.

Treatment System - The groundwater treatment system will consist of a treatment train of several technologies. A typical process schematic of the type of treatment system included under this RAA is presented on Figure 4-4. Once extracted, the contaminated groundwater will be pumped to an on-site pretreatment system for the removal of inorganic COCs (such as arsenic, barium, beryllium, chromium, lead, manganese, mercury, and vanadium). The inorganic removal system may include a combination of filtration, neutralization and precipitation. Please note that the other process options applicable to inorganic removal that passed the screening in Section 2.5 are still potential technologies, and are represented by the above-mentioned technologies included in this RAA. Bench-scale treatability studies and/or literature searches will be required to design the pretreatment system. Residuals generated from the pretreatment system such as sludges will need to be tested and disposed of properly. Based on the metals concentrations of the residuals, disposal may be at an off-site landfill.

The pretreated effluent from the inorganic removal system will be pumped to an on-site treatment system which may consist of a combination of biological and physical/chemical treatment, or of physical/chemical treatment. The treatment train will be designed for the removal of organic COCs including tetrachloroethene (PCE), trichloroethene (TCE), vinyl chloride, 1,2-dichloroethane (1,2-DCA), Trans-1,2-dichloroethene (T-1,2-DCE), and ethylbenzene.

If a biological system is used in the treatment train, the biological system will consist of anaerobic and aerobic bioreactors. The use of the biological system will be based on economics alone. The combination of biological treatment followed by physical/chemical treatment may save costs associated with the operation and maintenance of the physical/chemical system. An economic analysis based on the results of bench-scale treatability studies will be necessary to determine whether the overall cost of the biological system is feasible.

The physical/chemical treatment system will consist of an air stripping unit and an activated carbon adsorption unit. The air stripping unit will be designed for the removal of the volatile organic COCs, and for a maximum flow of approximately 930 gpm (based on six deep wells pumping at a rate of 150 gpm and six shallow wells pumping at 5 gpm).

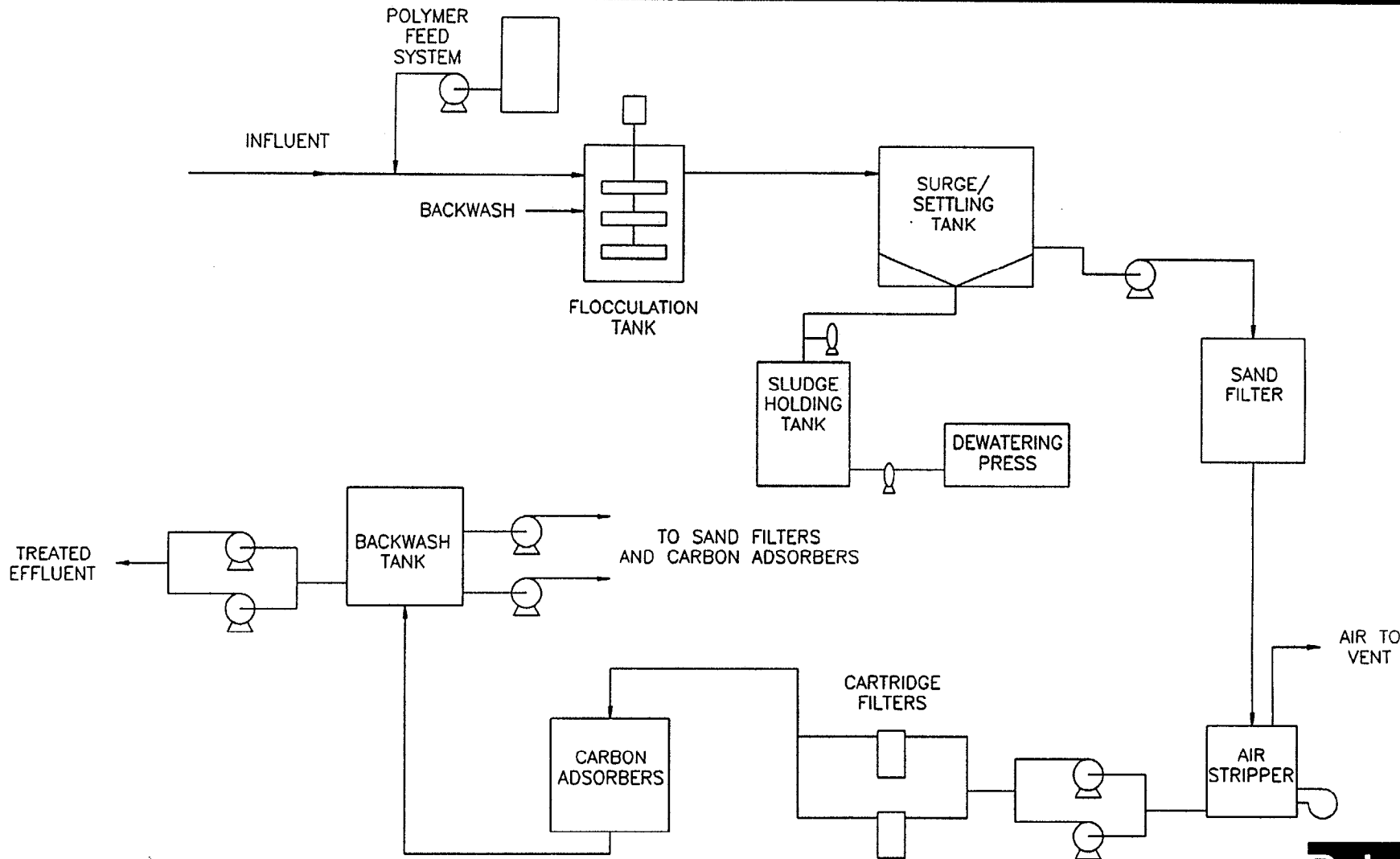

Baker
Baker Environmental, Inc.

FIGURE 4-4
GROUNDWATER TREATMENT
TRAIN SCHEMATIC
FEASIBILITY STUDY CTO-0133
MARINE CORPS BASE, CAMP LEJEUNE
NORTH CAROLINA

Residuals generated from the air stripper will include air emissions contaminated with organics. Based on the VOC levels in the groundwater, it is assumed that vapor recovery equipment, such as vapor-phase activated carbon or catalytic oxidizers, will be required to prevent the release of organics into the atmosphere. The vapor recovery equipment will generate additional waste contaminated with organics which will require proper off-site disposal or regeneration.

The aqueous effluent from the stripper will be pumped to the activated carbon adsorption unit for final removal (polishing) of the organic compounds. The carbon adsorption system will include granular activated carbon (GAC). The final design of the carbon system will be based on the contact time determined from bench-scale test results. Spent carbon generated from this process will either be properly disposed off site, shipped to a carbon regeneration facility, or regenerated on site. If the carbon is regenerated on site, a source of steam and cooling water will be required and an additional waste stream will be generated. The selection of one of the three spent carbon options will be based on economics. Typically, off-site disposal or off-site regeneration of spent carbon is more economical than on-site regeneration for small volumes of water. It should be noted that not all organic chemicals are carbon adsorbable and that additional measures may be necessary at final treatment to achieve the required discharge limits. Note that air emissions will be monitored during groundwater treatment activities.

Discharge of the Treated Water - Treated water will be discharged to Wallace Creek.

Institutional Controls

Groundwater RAA No. 3 will include the same three institutional controls included with Groundwater RAA No. 2: long-term groundwater monitoring, aquifer-use restrictions, and deed restrictions. Therefore, the discussion of institutional controls presented in Section 4.1.1.2 for Groundwater RAA No. 2 applies to this RAA.

In the event that the long-term groundwater monitoring program indicates that the groundwater conditions are deteriorating, other actions will be taken. These actions could include a modification of pumping rates at each well or the installation of additional wells as needed. In addition, since contaminants will remain at the site under this alternative, the USEPA is required by the NCP [40 CFR 300.515(e)(ii)] to review the effects of this alternative no less often than every five years.

4.1.1.4 Groundwater RAA No. 4: Intensive Groundwater Extraction and Treatment

In general, RAA No. 4: Intensive Groundwater Extraction and Treatment focuses on remediating the plumes of groundwater with the highest level of contamination. The rationale for this approach is that the majority of the groundwater contamination can be isolated and handled more feasibly than the entire area of impacted groundwater. Groundwater extraction and treatment will continue until the remediation goals are met. In addition, this RAA includes the same institutional controls as Groundwater RAA Nos. 2, and 3. The objective of this RAA is to focus on the worst area of groundwater contamination. The placement of wells within this area should result in a cone of influence that will capture contaminants at the downgradient edge of the plume over time. The major components of Groundwater RAA No. 4 are displayed on Figure 4-5 and described below.

Groundwater Treatment

Under this RAA, the area of the contaminated groundwater plume (both shallow and deep) originating from Site 82 with the highest level of contamination will be extracted and treated via a network of extraction wells placed within the plume area. Extracted groundwater will be treated on site via one of a combination of applicable treatment options (treatment train), and then discharged to Wallace Creek. Details of the extraction system and treatment system are discussed below.

Groundwater Extraction System - Under this RAA, groundwater in both the shallow and deep portions of the aquifer in the area of highest levels of contamination will be withdrawn through a series of extraction wells. Preliminary aquifer characteristics used to estimate the number of extraction wells needed and the estimated groundwater extraction flow rate have been based on the EPA's Wellhead Protection Area computer program, version 2.0 (Geophex, 1991). As stated for RAA No. 3, this model was based on a transmissivity of 15,000 square feet per day, and an effective porosity of 0.25.

For this FS and based on the above-mentioned factors, RAA No. 4 will include the installation of two 6-inch extraction wells installed at a depth of 110 feet, pumping at a rate of 150 gpm. This RAA also includes the installation of three shallow extraction wells pumping at a rate of 5 gpm and installed at a depth of 35 feet. The proposed locations of the extraction wells are shown on Figure 4-5. The proposed extraction wells will be

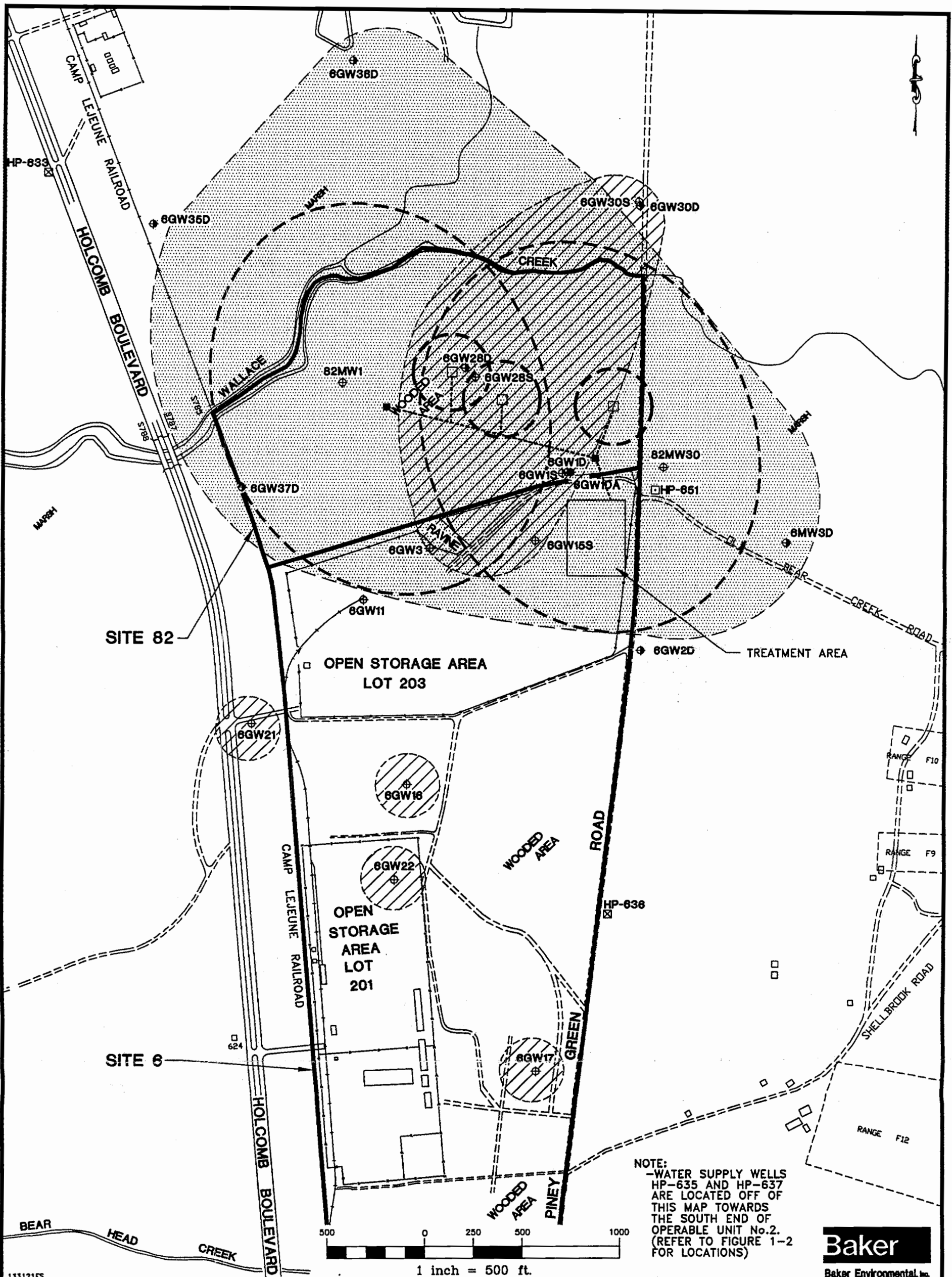

NOTE:
 -WATER SUPPLY WELLS
 HP-635 AND HP-637
 ARE LOCATED OFF OF
 THIS MAP TOWARDS
 THE SOUTH END OF
 OPERABLE UNIT No.2.
 (REFER TO FIGURE 1-2
 FOR LOCATIONS)

Baker
 Baker Environmental, Inc.

LEGEND	
— PIPING	PROPOSED DEEP EXTRACTION WELLS
□ PIPING	PROPOSED SHALLOW EXTRACTION WELLS
⊕ 6GW18	SHALLOW MONITORING WELL INCLUDED IN MONITORING PROGRAM
⊕ 6GW10	DEEP MONITORING WELL INCLUDED IN MONITORING PROGRAM
⊕ HP-636	WATER SUPPLY WELL (TO BE MONITORED)
⊕ HP-661	WATER SUPPLY WELL (CLOSED)
⊕	APPROXIMATE AREA OF GROUNDWATER (DEEPER PORTION) CONTAMINATION EXCEEDING REMEDIATION GOALS
⊕	APPROXIMATE AREA OF GROUNDWATER (SHALLOW PORTION) CONTAMINATION EXCEEDING REMEDIATION GOALS
⊕	ESTIMATED ZONE OF CAPTURE

SOURCE: LANTDIV, FEBRUARY 1992

FIGURE 4-5
 GROUNDWATER RAA No.4:
 INTENSIVE GROUNDWATER EXTRACTION
 AND TREATMENT
 FEASIBILITY STUDY CTO-0133
 MARINE CORPS BASE, CAMP LEJEUNE
 NORTH CAROLINA

01483 CC06Z

4-14

centered on the area of the highest contamination (near monitoring well 6GW1D for the deep wells and near monitoring wells 6GW34 and 6GW28S for the shallow wells) and immediately downgradient of this area. A radius of influence of 150 feet and a pumping rate of 5 gpm was assumed for the shallow extraction wells. Note that no extraction wells are located near the smaller shallow groundwater plumes west and south of Storage Lot 203 since the objective of this RAA is to extract and treat the worst area of groundwater contamination. Additional extraction wells will be added to the system if groundwater monitoring indicates that the groundwater is significantly deteriorating in other areas of the site.

Treatment System - Groundwater RAA No. 4 will include the same type of treatment system as Groundwater RAA No. 3. Therefore, the discussion of the pretreatment and treatment systems presented in Section 4.1.1.3 applies to this RAA. The only major difference in the groundwater treatment systems will be the size, capacity, and the concentrations of the contaminants being treated.

Under RAA No. 4, the groundwater will be extracted from 5 extraction wells instead of 12 (as with RAA No. 3), therefore, the required capacity of the treatment system for RAA No. 4 will be significantly less (i.e., approximately 315 gpm).

Discharge of the Treated Water - The treated groundwater will be discharged in the same manner as discussed under RAA No. 3.

Institutional Controls

Groundwater RAA No. 4 will include the same three institutional controls included with Groundwater RAAs Nos. 2 and 3: long-term groundwater monitoring, aquifer-use restrictions, and deed restrictions. Therefore, the discussion of institutional controls presented in Section 4.1.1.2 for Groundwater RAA No. 2 applies to this RAA.

In the event that the long-term groundwater monitoring program indicates that the groundwater conditions are deteriorating, other actions will be taken. In addition, since contaminants will remain at the site under this alternative, the USEPA is required by the NCP [40 CFR 300.515(e)(ii)] to review the effects of this alternative no less often than every five years.

4.1.1.5 Groundwater RAA No. 5: Groundwater Extraction and Treatment

In general, RAA No. 5: Groundwater Extraction and Treatment includes the removal of the suspected sources of groundwater contamination and treatment of the entire plume of groundwater contamination (both shallow and deep). In addition, this RAA includes the same institutional controls as Groundwater RAA Nos. 2, 3 and 4. The objective of this RAA is to eliminate the contaminants in the groundwater and to mitigate the further migration of the existing groundwater plumes. The major components of Groundwater RAA No. 5 are displayed on Figure 4-6 and described below.

Groundwater Treatment

Under this RAA, the entire area of the contaminated groundwater plume originating from Site 82 will be extracted and treated via a network of extraction wells placed within the plume area. Extracted groundwater will be treated on site via one of a combination of applicable treatment options (treatment train), and then discharged to Wallace Creek. Details of the extraction system and treatment system are discussed below.

Groundwater Extraction System - Under this RAA, groundwater in both the shallow and deep portions of the aquifer will be withdrawn through approximately eight extraction wells. Preliminary aquifer characteristics used to estimate the number of extraction wells needed and the estimated groundwater extraction flow rate have been based on the EPA's Wellhead Protection Area computer program, version 2.0 (Geophex, 1991). As stated for RAA No. 4, this model was based on a transmissivity of 15,000 square feet per day, and an effective porosity of 0.25.

For this FS and based on the above-mentioned factors, RAA No. 5 will include the installation of eight deep extraction wells installed at a depth of 110 feet, pumping at a rate of 150 gpm. This RAA also includes the installation of 12 shallow extraction wells pumping at a rate of 5 gpm and installed at a depth of 35 feet. The proposed locations of these extraction wells are shown on Figure 4-6. The locations for the deep wells were based on several factors including estimated radius of influence dimensions; spacings of overlapping cones of depressions; accessibility; and location with respect to Wallace Creek. A radius of influence of 150 feet and a pumping rate of 5 gpm were assumed for the shallow extraction wells. Note that no extraction wells are located near the smaller shallow groundwater plumes west and south of Storage Lot 203. Additional extraction wells will

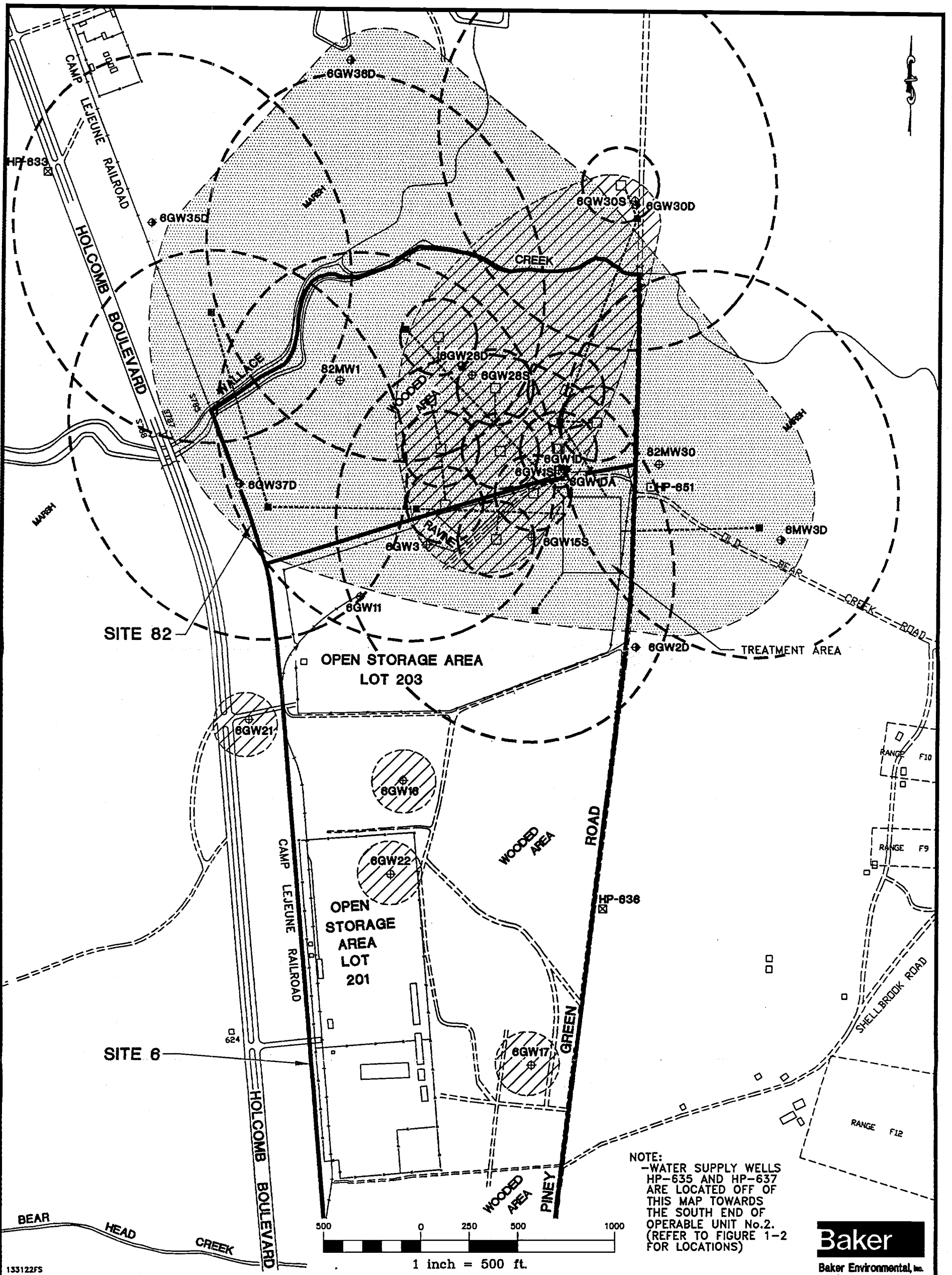

4-17

LEGEND	
<ul style="list-style-type: none"> ■ PIPING PROPOSED DEEP EXTRACTION WELLS □ PIPING PROPOSED SHALLOW EXTRACTION WELLS ⊕ 6GW18 SHALLOW MONITORING WELL INCLUDED IN MONITORING PROGRAM ⊕ 6GW19 DEEP MONITORING WELL INCLUDED IN MONITORING PROGRAM ⊕ HP-636 WATER SUPPLY WELL (TO BE MONITORED) ⊕ HP-651 WATER SUPPLY WELL (CLOSED) 	<ul style="list-style-type: none"> ● APPROXIMATE AREA OF GROUNDWATER (DEEPER PORTION) CONTAMINATION EXCEEDING REMEDIATION GOALS ▨ APPROXIMATE AREA OF GROUNDWATER (SHALLOW PORTION) CONTAMINATION EXCEEDING REMEDIATION GOALS ○ ESTIMATED ZONE OF CAPTURE

SOURCE: LANTDIV, FEBRUARY 1992

FIGURE 4-6
GROUNDWATER RAA No.5:
GROUNDWATER EXTRACTION AND TREATMENT
FEASIBILITY STUDY CTO-0133
 MARINE CORPS BASE, CAMP LEJEUNE
 NORTH CAROLINA



0148300072

be added to the system if groundwater monitoring indicates that the groundwater is significantly deteriorating in other areas of the site.

Treatment System - Groundwater RAA No. 5 will include the same type of treatment system as Groundwater RAA Nos. 3 and 4. Therefore, the discussion of the groundwater pretreatment and treatment systems presented in Section 4.1.1.3 applies to this RAA. The only major difference in the groundwater treatment systems will be the size, capacity, and the concentrations of the contaminants to be treated.

Since under RAA No. 5, the groundwater will be extracted from 20 extraction wells instead of 12 (as with RAA No. 3), the capacity of the treatment system for RAA No. 5 will need to be approximately 1,260 gpm.

Discharge of the Treated Water - The treated groundwater will be discharged via injection wells or to the New River because the higher flow rate may cause flooding along Wallace Creek.

Institutional Controls

Groundwater RAA No. 5 will include the same three institutional controls included with Groundwater RAAs Nos. 2, 3, and 4: long-term groundwater monitoring, aquifer-use restrictions, and deed restrictions. Therefore, the discussion of institutional controls presented in Section 4.1.1.2 for Groundwater RAA No. 2 applies to this RAA.

In the event that the long-term groundwater monitoring program indicates that the groundwater conditions are deteriorating, other actions will be taken. In addition, since contaminants will remain at the site under this alternative, the USEPA is required by the NCP [40 CFR 300.515(e)(ii)] to review the effects of this alternative no less often than every five years.

4.1.2 Soil RAAs

As shown in Table 4-2, seven Soil RAAs have been developed for OU No. 2. Each of these RAAs are described below.

4.1.2.1 Soil RAA No. 1 No Action

Under Soil RAA No. 1, no remedial actions will be performed to reduce the toxicity, mobility, or volume of contaminants in the soil at OU No. 2. The No Action RAA is required by the NCP to provide a baseline for comparison with other soil alternatives that provide a greater level of response. Soil RAA No. 1 involves leaving the contaminated soils from Site 82 and Site 6 in place. Under this RAA, the VOC and pesticide concentrations in the soil may slowly decrease as a result of natural biodegradation. The natural degradation of the PCB-contaminated soils is unknown.

The no action alternative is required by the NCP to provide a baseline for comparison with other RAAs. Since contaminants will remain at the site under this alternative, the USEPA is required by the NCP [40 CFR 300.515(e)(ii)] to review the effects of this alternative no less often than every five years.

4.1.2.2 Soil RAA No. 2: Capping

In general, Soil RAA No. 2 includes the excavation and consolidation of the soils from all of the Soil AOCs and placement under a multilayered cap located within Open Storage Lot 203. As shown in Table 4-2, the technologies/process options included with this RAA include monitoring, deed restrictions, fencing, capping, grading, revegetation, and soil excavation. Figure 4-7 depicts the approximate areas of the site from which soil will be excavated, and also shows the proposed location of the on-site cap.

The principal objectives of this RAA are to consolidate the contaminated soils into one area, to prevent the potential for direct physical contact with the contaminated soils, and to prevent the potential for the migration of contaminants by surface water infiltration. This RAA will reduce the mobility of the COCs in the soil, but will not reduce the toxicity or the volume of the contaminants. The main components of this alternative are described below.

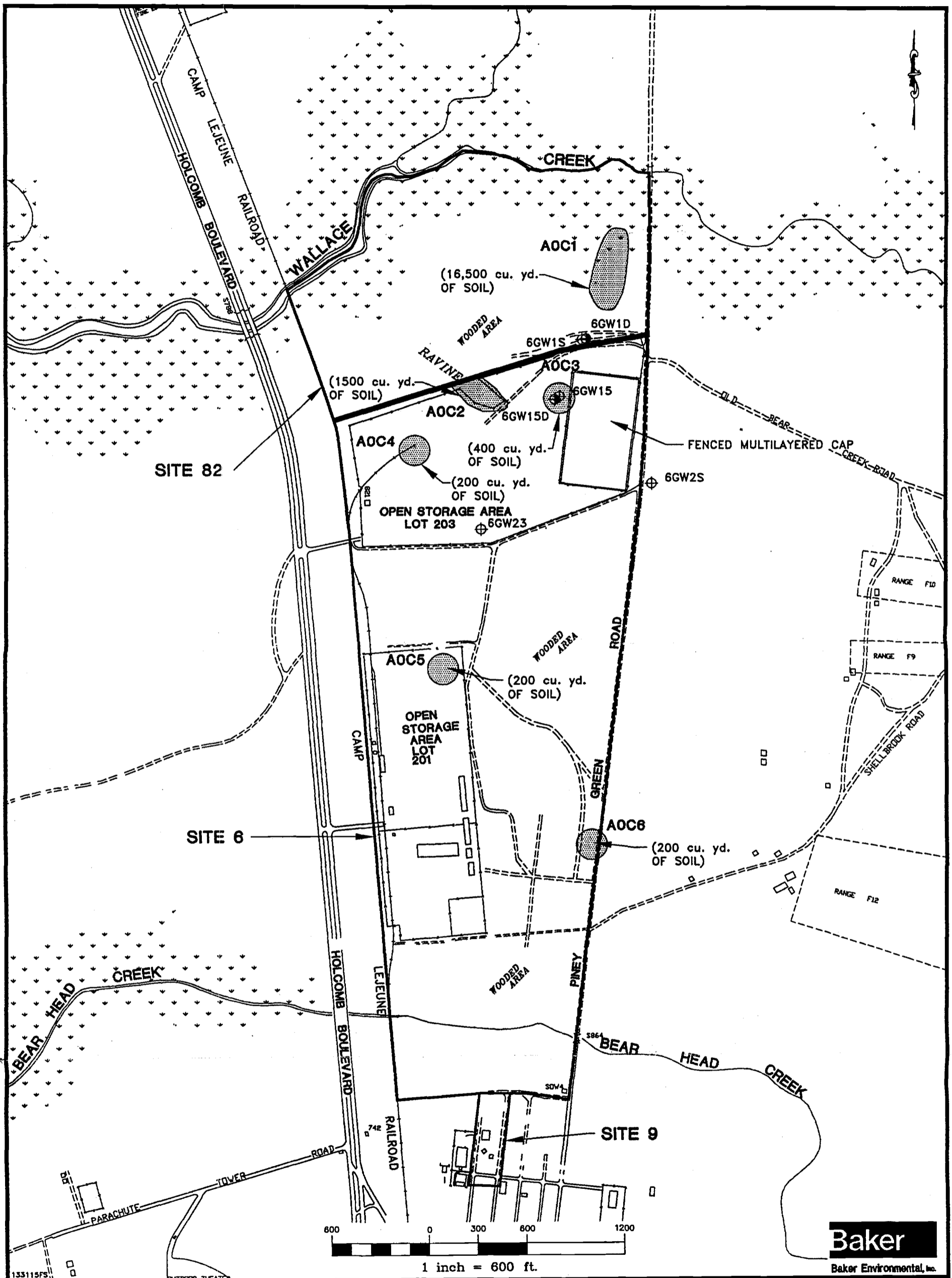

4-20

Baker
Baker Environmental, Inc.

LEGEND	
6GW23	SHALLOW MONITORING WELL INCLUDED IN MONITORING PROGRAM
6GW1D	DEEP MONITORING WELL INCLUDED IN MONITORING PROGRAM
AOC1	AREA OF CONCERN; EXCAVATION TO TAKE PLACE WITHIN THIS AREA

FIGURE 4-7
SOIL RAA NO. 2: CAPPING
FEASIBILITY STUDY CTO-0133

MARINE CORPS BASE, CAMP LEJEUNE
NORTH CAROLINA

SOURCE: LANTDIV, FEBRUARY 1992

01483CC082

Excavation - Excavation of soil at OU No. 2 could be accomplished by utilizing several different types of equipment and typical construction activities. Typical excavation machinery include backhoes, dozers, scrapers, and loaders. A backhoe can excavate soils to a maximum depth of approximately 30 feet. Dozers and loaders are typically used for grading and earth-moving operations. Scrapers are generally used to excavate surface soils and respreading and compacting cover soils. For OU No. 2, it appears that any of these machinery would be applicable for the shallow soil excavation activities required under this RAA.

The contaminated soils within each Soil AOC will be excavated, placed into dump trucks, transported to Lot 203, and piled into the designated cap area. Prior to excavation activities, where applicable, land clearing, tree removal, and debris removal activities will be conducted. The limits of the excavations will be defined by constituent concentrations in excess of the specified remediation goals. For FS estimating purposes, approximately 19,000 cubic yards of soil will be excavated. This estimation was based on Soil AOC1 (based on a 4-foot excavation over approximately 2.5 acres); 1,500 cubic yards of soil from AOC2 (based on a 2-foot excavation over an area approximately 20,000 square feet; 400 cubic yards of soil from AOC3 (based on a four-foot excavation over a 2,700 square foot area); and 200 cubic yards each from AOCs 4, 5, and 6 (based on a two-foot excavation over a 2,700 square foot area). Confirmation soil sampling will be conducted during the excavation activities to determine the lateral and vertical extent of each soil excavation. The samples will be analyzed for the specific COCs within each Soil AOC.

Note that prior to any excavation activities, site operating areas for equipment and personnel decontamination will be constructed. The equipment decontamination area will be equipped with a steam cleaning pad with proper containment for rinse water.

Capping - Following excavation activities, a multilayered cap will be installed over the contaminated soils. The approximate areal extent of the cap is depicted in Figure 4-8. For purposes of this FS, the cap will be approximately 400 feet wide by 700 feet long. The contaminated soil will be spread approximately one to two feet thick in the capped area. A typical multilayered cap is presented on Figure 4-8.

The cap will consist of a vegetated top cover, a middle drainage layer, and a low permeability bottom layer. The low permeability layer will be placed on the compacted and graded contaminated soils. This layer will consist of approximately two feet of clay overlain by six inches of sand, and a high-density polyethylene (HDPE) liner. Approximately six inches of

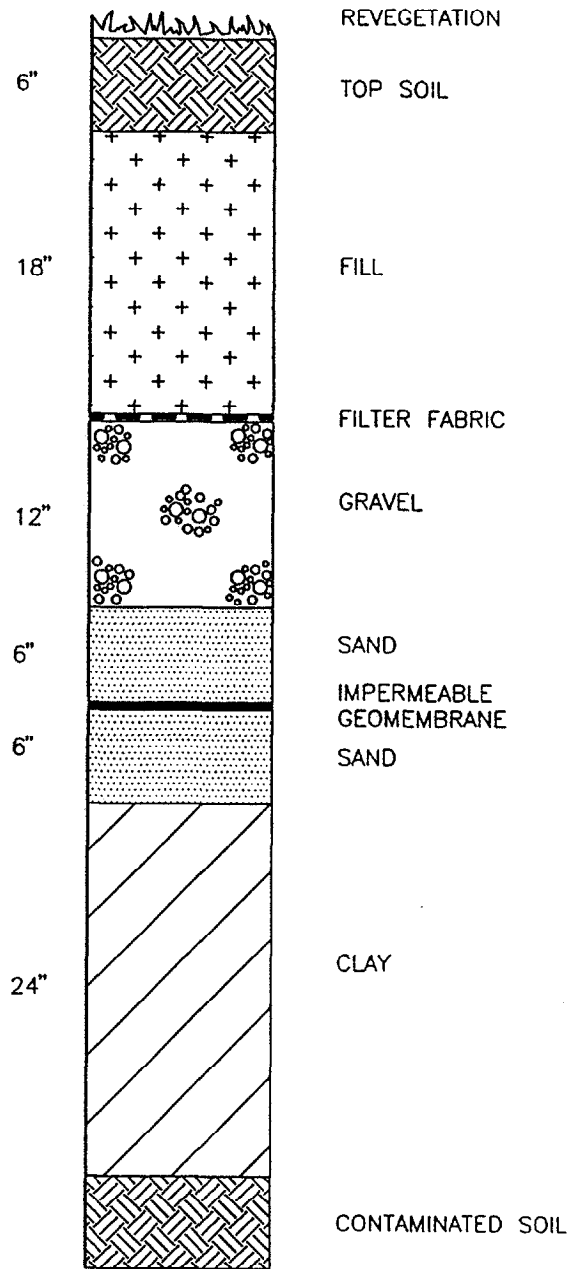

FIGURE 4-8
TYPICAL MULTILAYERED CAP
FEASIBILITY STUDY CTO-0133

MARINE CORPS BASE, CAMP LEJEUNE
NORTH CAROLINA

sand will also be placed on top of the liner. Next, a one-foot thick middle gravel drainage layer will be placed over the upper sand layer. This layer will be designed to have an hydraulic conductivity greater than or equal to 1×10^{-3} centimeters per second. Filter fabric will be placed on top of the gravel drainage layer. This fabric prevents fine grained soil particles from clogging the gravel layer. The final cap layer will consist of approximately 18 inches of soil fill topped with six inches of topsoil. The cap surface will be graded and then vegetated. Erosion due to potential surface water runoff will be controlled by a drainage system that will redirect the runoff.

To ensure the integrity of the capping system, periodic maintenance will be required. In addition, the cap surface will be regularly mowed. Note that air emissions will be monitored during all soil remediation activities.

Surface Controls - The excavated areas will be graded to conform to the surrounding terrain. Clean fill may be added to the excavated areas as necessary to bring the areas up to grade. The excavated areas will be revegetated.

Monitoring - In order to monitor the effectiveness of the cap (i.e., the migration of the COCs), groundwater sampling will be conducted semiannually. Groundwater samples will be collected from six monitoring wells: 6GW15, 6GW15D, 6GW1S, 6GW1D, 6GW2S, and 6GW23.

Access Restrictions - The capped area will be fenced to restrict access to the capped area and reduce damage to the cap. The new fencing will connect to the existing fence at Lot 203, along the eastern side of the lot. This RAA will require approximately 1,500 linear feet of new chain-link fence to be installed. The fence will be of sufficient height and construction so as to limit access to the cap. In addition, No Trespassing signs will be posted along the fence to further deter access. Routine maintenance and repairs of the fence, as necessary, are also included under this RAA. In addition to the fence, deed restrictions restricting the use of the area in and around Lot 203 will be implemented. Any soil excavated during potential future construction activities will require appropriate disposal in accordance with applicable Federal and State regulations.

In the event that the long-term groundwater monitoring program indicates that the groundwater conditions are deteriorating, other actions will be taken. In addition, since contaminants will remain at the site under this alternative, the USEPA is required by the

NCP [40 CFR 300.515(e)(ii)] to review the effects of this alternative no less often than every five years.

4.1.2.3 Soil RAA No. 3: On-Site Treatment

In general, Alternative 3 includes the excavation and treatment of the soils from all of the Soil AOCs via on-site treatment. As shown in Table 4-2, the technologies/process options included with this RAA include soil excavation, grading, revegetation, fencing, and on-site treatment. Figure 4-9 depicts the approximate areas of the site from which soil will be excavated, and also shows the proposed location of the on-site treatment area. The main components of this alternative are described below.

Excavation - Excavation of soil at OU No. 2 could be accomplished by utilizing several different types of equipment and typical construction activities. Typical excavation machinery include backhoes, dozers, scrapers, and loaders. A backhoe can excavate soils to a maximum depth of approximately 30 feet. Dozers and loaders are typically used for grading and earth-moving operations. Scrapers are generally used to excavate surface soils and respreading and compacting cover soils. For OU No. 2, it appears that any of these machinery would be applicable for the shallow soil excavation activities required under this RAA.

The contaminated soils within each Soil AOC will be excavated, placed into dump trucks, transported to the on-site treatment area (or soil staging area). The limits of the excavations will be defined by constituent concentrations in excess of the specified remediation goals. For FS estimating purposes, approximately 19,000 cubic yards of soil will be excavated. This estimation was based on Soil AOC1 having 16,500 cubic yards of soil, AOC2 having 1,500 cubic yards of soil, AOC3 having 400 cubic yards of soil, and the other three Soil AOCs each having 200 cubic yards of soil. Confirmation soil sampling will be conducted during the excavation activities to determine the lateral and vertical extent of each soil excavation. The samples will be analyzed for the specific COCs within each AOC. Please note that excavation will not be necessary for AOC1 if in situ volatilization is selected as an on-site treatment technology.

Prior to any excavation activities, site operating areas for soil staging and for decontamination will be constructed. The staging area will be used for the interim storage of excavated soils prior to treatment, if applicable. During storage periods, the soil will be covered to prevent the potential leaching of contaminants, dust generation, and potential for

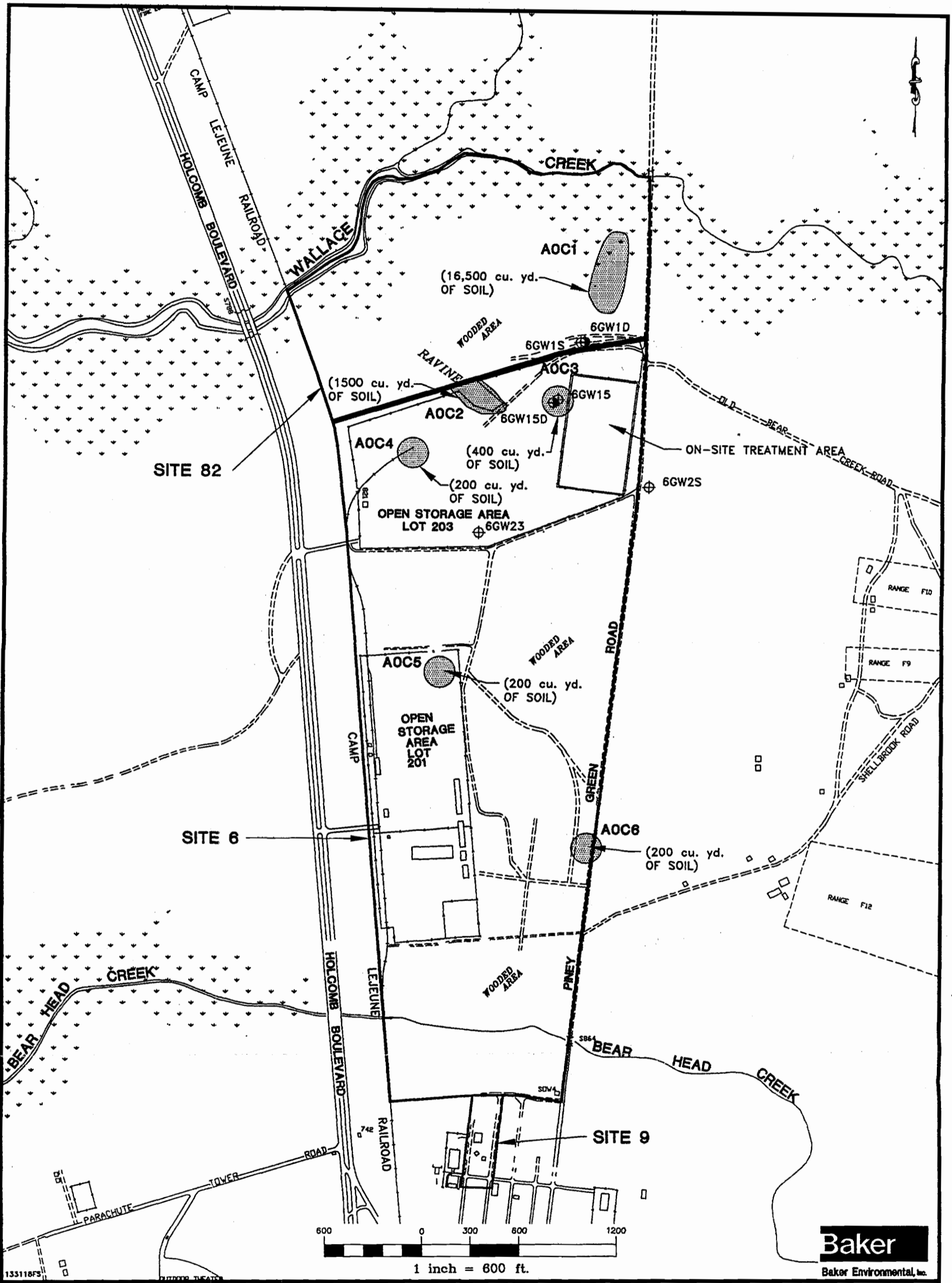

Baker
Baker Environmental, Inc.

LEGEND	
⊕	6GW23 SHALLOW MONITORING WELL INCLUDED IN MONITORING PROGRAM
⊕	6GW1D DEEP MONITORING WELL INCLUDED IN MONITORING PROGRAM
●	AOC1 AREA OF CONCERN; EXCAVATION TO TAKE PLACE WITHIN THIS AREA

FIGURE 4-9
SOIL RAA NO. 3:
ON-SITE TREATMENT
FEASIBILITY STUDY CTO-0133
MARINE CORPS BASE, CAMP LEJEUNE
NORTH CAROLINA

SOURCE: LANTDIV, FEBRUARY 1992

01483CC09Z

surface water runoff contamination. The equipment decontamination area will be equipped with a steam cleaning pad with proper containment for rinse water.

Treatment - Following excavation activities, the soils will be transported to the on-site treatment area. Depending on the type of contaminants, different treatment techniques may be required at the site. For the purpose of this FS, four treatment technologies/process options have been retained as applicable for the COCs in the soils at the operable unit. They include land treatment, in situ volatilization, chemical dechlorination, and incineration.

Land treatment would be applicable for soils contaminated with biodegradable organics such as VOCs and nonchlorinated pesticides. In situ volatilization (also commonly referred to as vapor extraction) would be applicable for the VOC-contaminated soils and, to a lesser degree, SVOC-contaminated soils. Chemical dechlorination would be applicable for the PCB-contaminated soils. Whereas, a mobile incinerator would be applicable to all of the soil COCs. Table 4-3 presents a listing of which of these technologies are applicable to which Soil AOCs. The decision as to what technology or technologies will be used under this RAA will be based on economics and implementability (refer to the detailed evaluation presented in Section 5.0). A brief discussion of each of these technologies is presented below.

Land Treatment - Land treatment or landfarming is the process by which affected soils are excavated and spread over an area to enhance naturally occurring process such as volatilization, aeration, biodegradation, and photolysis (Weston, 1988). Soils highly contaminated with VOCs and SVOCs may be treated via land treatment or landfarming. This procedure involves spreading the soil in a thin layer (up to 18 inches), applying moisture and nutrients, if necessary, and mechanically aerating the soil to enhance biodegradation and promote volatilization for removal of contaminants. When less volatile products are involved, biological treatment becomes the primary means of remediation and may require additional enhancement via the addition of natural microbial cultures. Continued tilling and moisture addition are necessary for optimum performance. After testing demonstrates that the contaminants are significantly reduced, the soil may be recompacted in the original excavation (Testa, 1991). Bench-scale or pilot-scale testing will be necessary for this technology.

A typical schematic of the land treatment process is presented on Figure 4-10. As shown on the figure, the treatment zone includes a zone of incorporation near the surface where most degradation occurs, and a deeper zone where leachable components become

TABLE 4-3

**APPLICABLE TECHNOLOGIES FOR THE SOIL AOCs
FEASIBILITY STUDY CTO-0133
MCB CAMP LEJEUNE, NORTH CAROLINA**

Treatment Technology	Areas of Concern					
	1	2	3	4	5	6
Land Treatment	X	X			X	
In situ Volatilization	X					
Chemical Dechlorination			X	X		X
Incineration	X	X	X	X	X	X

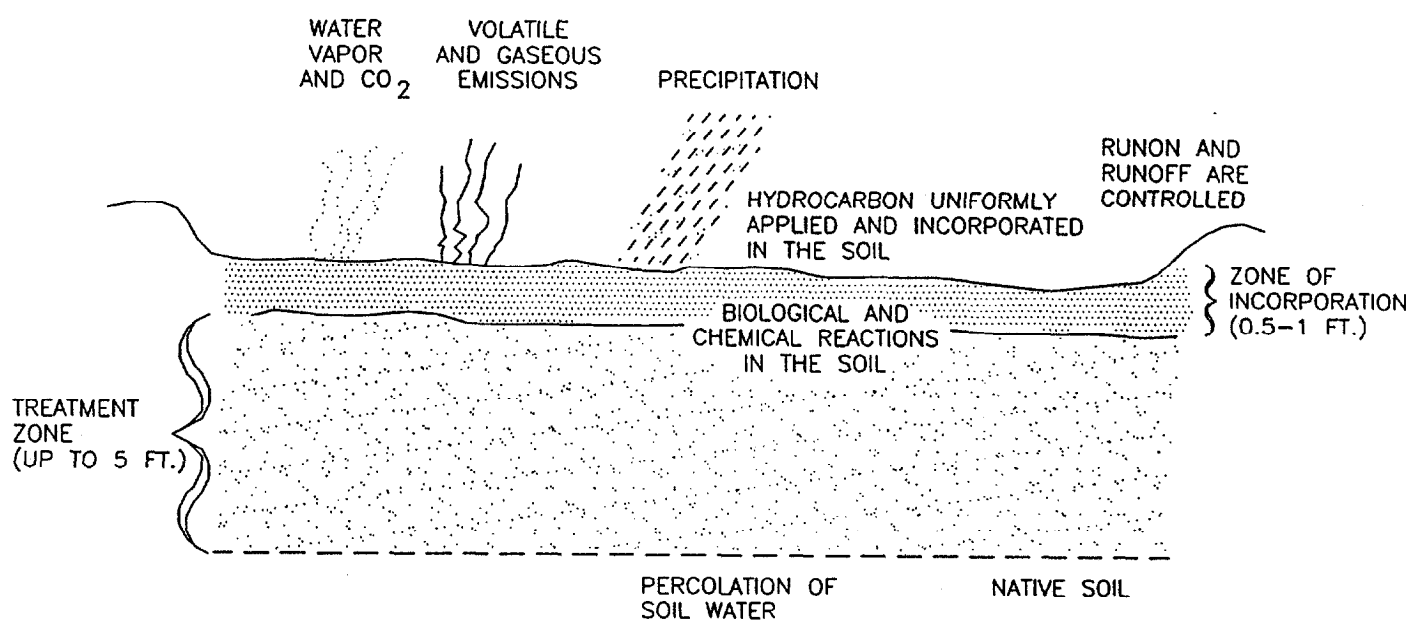

FIGURE 4-10
LAND TREATMENT SCHEMATIC
FEASIBILITY STUDY CTO-0133

MARINE CORPS BASE, CAMP LEJEUNE
NORTH CAROLINA

SOURCE: WESTON, 1988.

immobilized and degrade more slowly (Weston, 1988). Soil AOCs 1, 2, and possibly 5 may be applicable for this type of treatment.

In Situ Volatilization - In situ volatilization or soil vapor extraction is a technique for the removal of VOCs and some SVOCs from the vadose zone. The vadose zone is the subsurface soil zone located between the land surface and the top of the water table (USEPA, 1991c). In situ volatilization involves drawing air through the vadose zone via vapor recovery wells (see Figure 4-11). These recovery wells can be placed vertically or horizontally across a site (Sims, 1990). VOCs occurring as residual saturation transfers to the air and is withdrawn through the recovery wells. Vapor monitoring wells are constructed in a similar manner to an ordinary monitoring well, except that they are completed in the vadose zone. Generally, vacuum pumps, blower fans, or both are used to draw air through the formation and out of the extraction points (Testa, 1991). A typical schematic of the in situ volatilization process is shown on Figure 4-12. Some type of impermeable surface covering (e.g., plastic, clay, pavement) may be used to minimize the vertical draw of air flow from the atmosphere. Once collected, the vapors may require treatment. This treatment system usually is a combination of a vapor incinerator and catalytic oxidizer. If the vapors do not require treatment, they will be directly vented to the atmosphere through an appropriate diffuser stack. Pilot-scale testing will be necessary for this technology. Soil AOC1 appears to be applicable for this type of treatment.

Chemical Dechlorination - Potassium polyethylene glycolate (KPEG) dechlorination is a chemical treatment technology used to dehalogenate certain classes of chlorinated organics such as PCBs. The end products of this chemical reaction should be lower toxic, water soluble material. The KPEG solution reacts with the chlorinated organic and displaces a chlorine molecule. The KPEG process involves mixing equal portions of contaminated soil and KPEG reactants in a heated reactor. The slurry is then heated and mixed while the reaction occurs. The reaction time can range from 0.5 to 5 hours, depending on the type and concentration of the contaminants and the amount of dechlorination desired. The excess reagent is then decanted and the soil is washed two to three times with water to remove excess reagent and the products of the reaction. The decontaminated soil is then removed from the reactor. The decanted reagent and washes can be recycled to treat additional soil (USEPA, 1988c). A typical schematic of the dechlorination process is shown on Figure 4-13.

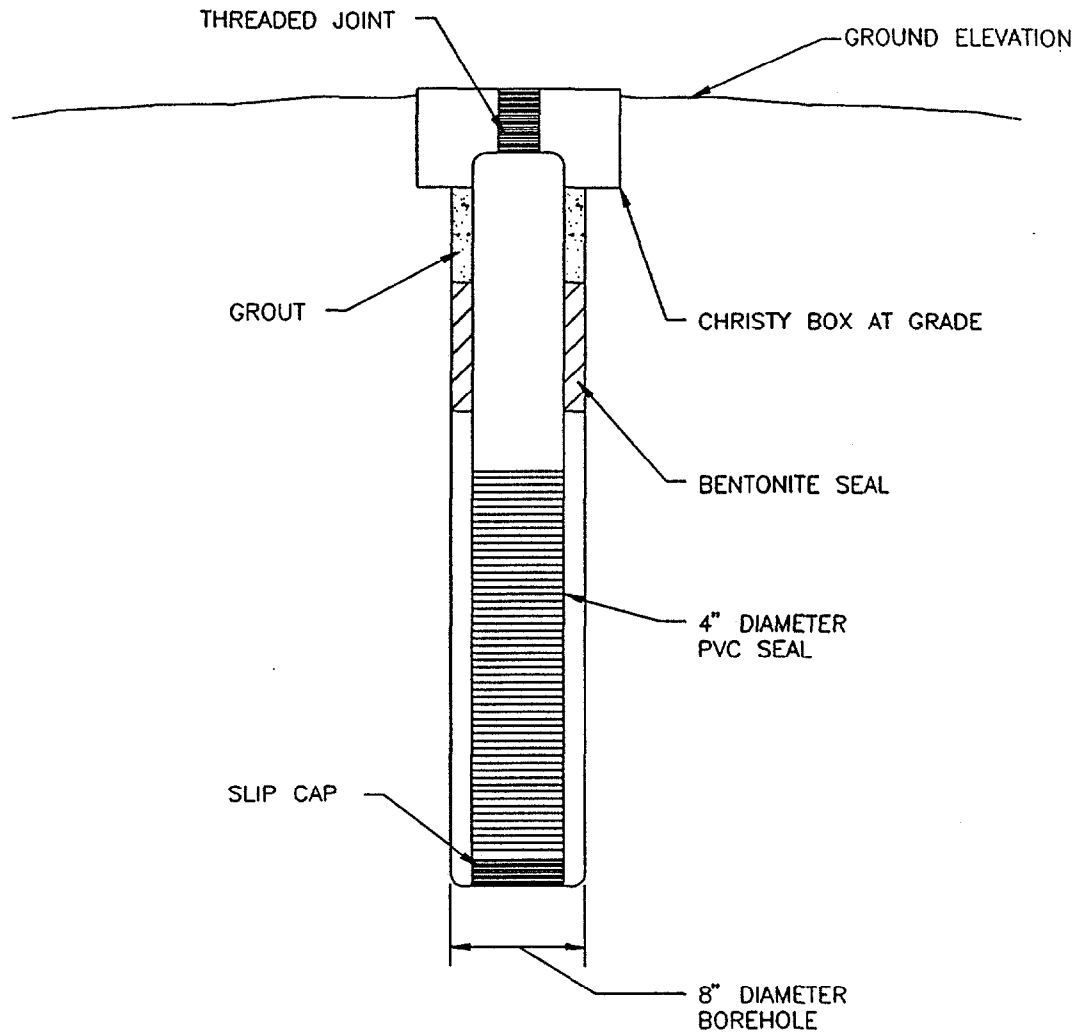

N.T.S.



FIGURE 4-11
VAPOR EXTRACTION WELL SCHEMATIC
FEASIBILITY STUDY CTO-0133

MARINE CORPS BASE, CAMP LEJEUNE
NORTH CAROLINA

SOURCE: WESTON, 1988.

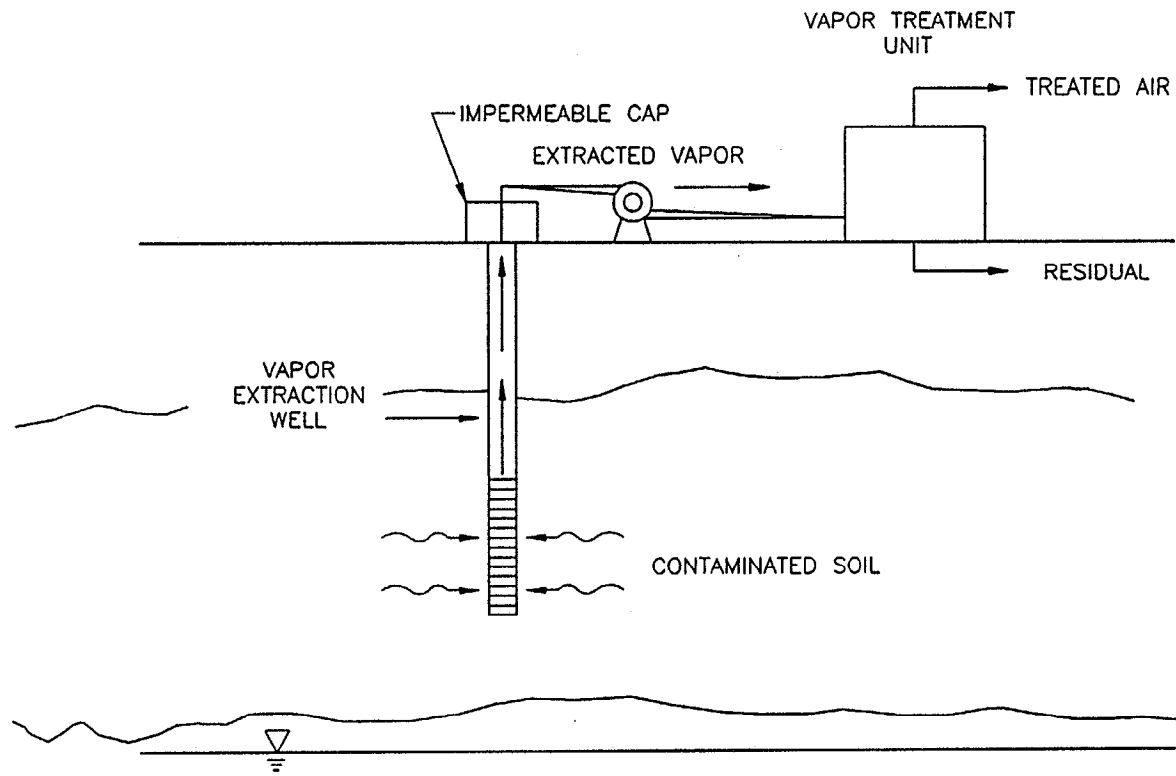
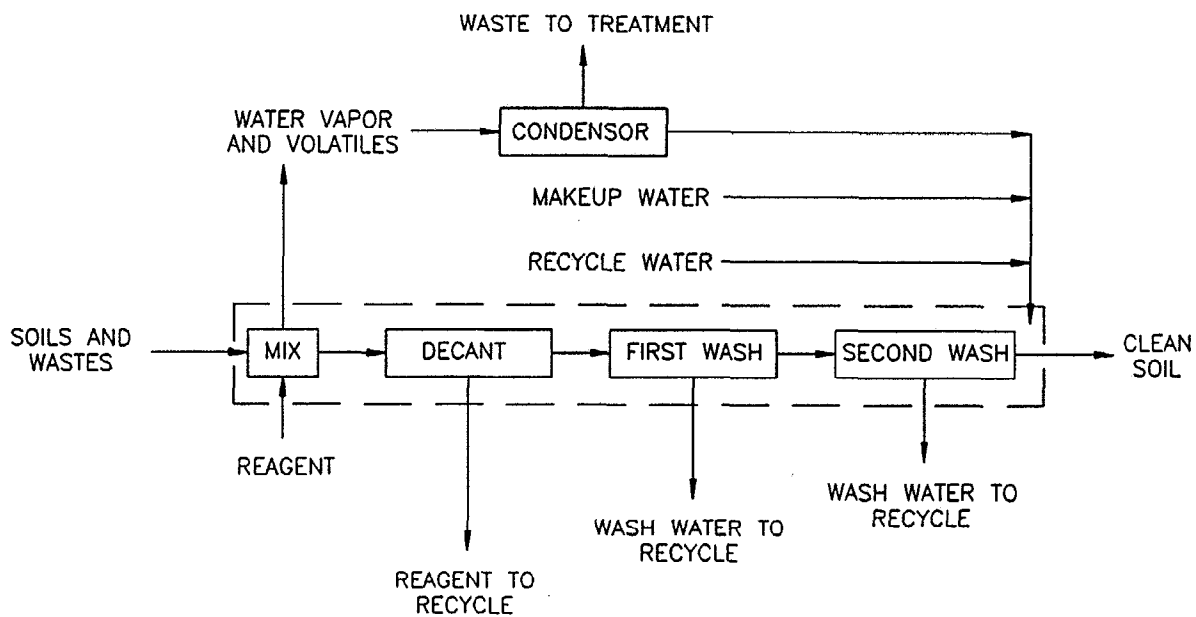

FIGURE 4-12
IN SITU VOLATILIZATION
SCHEMATIC
FEASIBILITY STUDY CTO-0133
MARINE CORPS CORPS, CAMP LEJEUNE
NORTH CAROLINA

4-31



Baker
Baker Environmental, Inc.

FIGURE 4-13
CHEMICAL DECHLORINATION
SCHEMATIC
FEASIBILITY STUDY CTO-0133

MARINE CORPS CORPS, CAMP LEJEUNE
NORTH CAROLINA

4-32

KPEG reduces the toxicity of the waste, but it also increases the volume of waste that must be further treated as wastewater (USEPA, 1988c). Treatability studies will have to be performed to determine the effectiveness of this technology on the type of PCB-contaminated soils that are at OU No. 2. The reaction is highly dependent on sufficient reaction time. The Soil AOCs 3, 4, and 6 appear to be applicable for this type of treatment.

Incineration - Incineration is a complete destruction technology that can be used to treat soils contaminated with a wide range of hazardous organic wastes. There are several types of combustion chambers that can be used in the incineration process such as rotary kiln, fluidized bed, multiple hearth, and liquid injection. The most conventional unit used for the treatment of soils on site is the rotary kiln incinerator. Rotary kiln incinerators consist of a mobile rotating kiln slightly tilted. Waste is typically introduced at the top of the kiln and burns as it slowly falls to the bottom of the unit, where it is removed as ash (typically has the appearance of fine beach sand). During operation, the kiln rotation exposes fresh soil surfaces to oxidation. Unburned gaseous and suspended particulate organics are burned in a secondary combustion chamber or afterburner. The off-gases require quenching and scrubbing prior to discharge into the environment. A mobile incinerator may be able to handle approximately 150 pounds of dry solids per minute. The operation of an incineration system results in the generation of residuals consisting of ash, scrubber water, and flue gases. The ash must be tested in accordance with TCLP and RCRA characteristic analyses to determine its potential for delisting. If the ash cannot be delisted, it will require handling as a hazardous waste. A general schematic of an incinerator process is presented on Figure 4-14. For purposes of this FS, it is assumed that the ash can be used as fill material within Lot 203 during restoration activities. Scrubber water will be treated in conjunction with a groundwater RAA. The flue gases emitted during the incineration process will be required to meet the standards set forth in RCRA regulations. Incineration appears to be applicable to all of the Soil AOCs.

Following treatment, any residual soils will be removed from the treatment unit, analyzed, and if permitted, used as backfill at the site. If not permitted, the treated soils will be properly disposed off site. Note that air emissions will be monitored during all soil remediation activities.

Surface Controls - The excavated areas will be graded to conform to the surrounding terrain. Clean fill may be added to the excavated areas as necessary to bring the areas up to grade. The excavated areas will be revegetated.

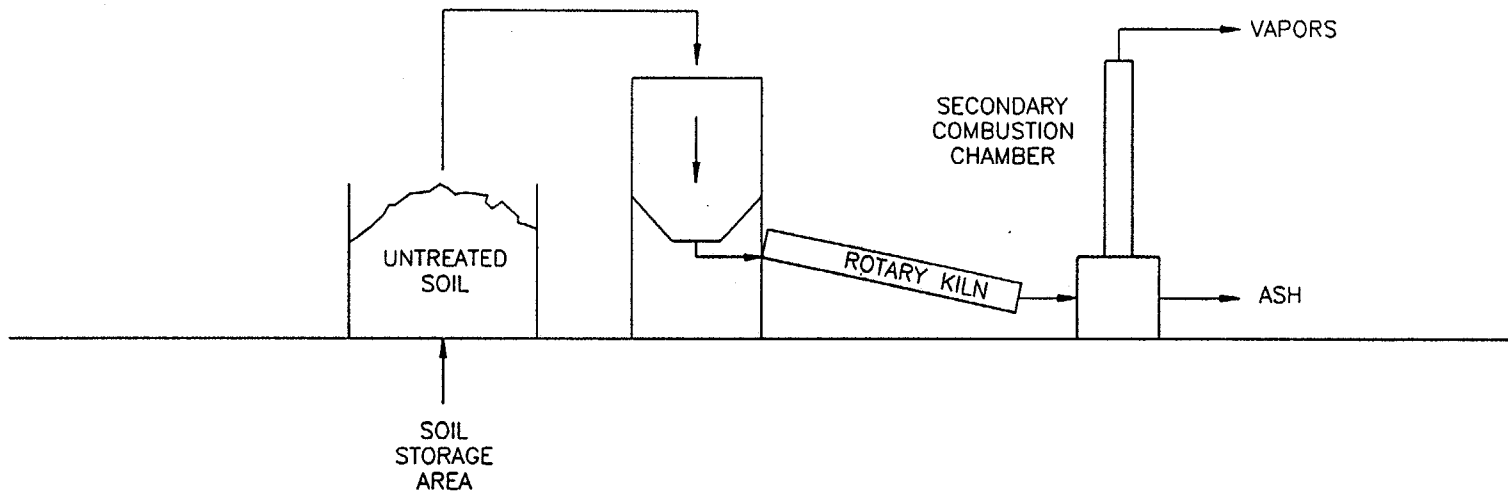

4-34

Baker
Baker Environmental, Inc.

FIGURE 4-14
INCINERATION SCHEMATIC
FEASIBILITY STUDY CTO-0133

MARINE CORPS CORPS, CAMP LEJEUNE
NORTH CAROLINA

Access Restrictions - The treatment area will be fenced to restrict access. The fencing will connect to the existing fence at Lot 203, along the eastern side of the lot. This RAA will require approximately 2,300 linear feet of new chain-link fence to be installed. The fence will be of sufficient height and construction so as to limit access to the cap. In addition, No Trespassing signs will be posted along the fence to further deter access. Routine maintenance and repairs of the fence, as necessary, are also included under this RAA.

4.1.2.4 Soil RAA No. 4: Capping and On-Site Treatment
(All Areas of Concern)

In general, Soil RAA No. 4 is a combination of Soil RAA Nos. 2 and 3. This RAA includes the excavation and consolidation of the PCB-contaminated soils and placement under a soil cover placed within Open Storage Lot 203 (i.e., capping); and the treatment of the soil from the remaining Soil AOCs (i.e., on-site treatment). As shown in Table 4-2, the technologies/process options included with this RAA include monitoring, deed restrictions, fencing, capping, grading, revegetation, soil excavation, and on-site treatment. Figure 4-15 depicts the approximate areas of soil that will be excavated, and also shows the proposed locations of the on-site soil cover and treatment areas.

The principal objectives of this RAA are to consolidate the PCB-contaminated soils into one area and to treat the other contaminated soils on site. The main components of this alternative are described below. The rationale behind this option is based primarily on the economics of treating PCB-contaminated soils, which in general, are significantly more costly than treatment options for soils contaminated with other constituents.

Excavation - The same excavation measures discussed under Soil RAA No. 2 will be implemented with this RAA. The only difference will be where the soils are taken. The PCB-contaminated soils (Soil AOCs 3, 4, and 6) will be excavated, placed into dump trucks, transported to Lot 203, and piled into the designated cap area. The limits of the excavations will be defined by constituent concentrations in excess of the specified remediation goals. For FS estimating purposes, approximately 400 cubic yards of PCB-contaminated soil will be excavated to a depth of 2 feet. This total includes 200 cubic yards from each of Soil AOCs 4 and 6. The soil cover will be placed directly over AOC3, therefore excavation will not be necessary. Confirmation soil sampling will be conducted during the excavation activities to determine the lateral and vertical extent of each soil excavation. The samples will be analyzed for PCBs.

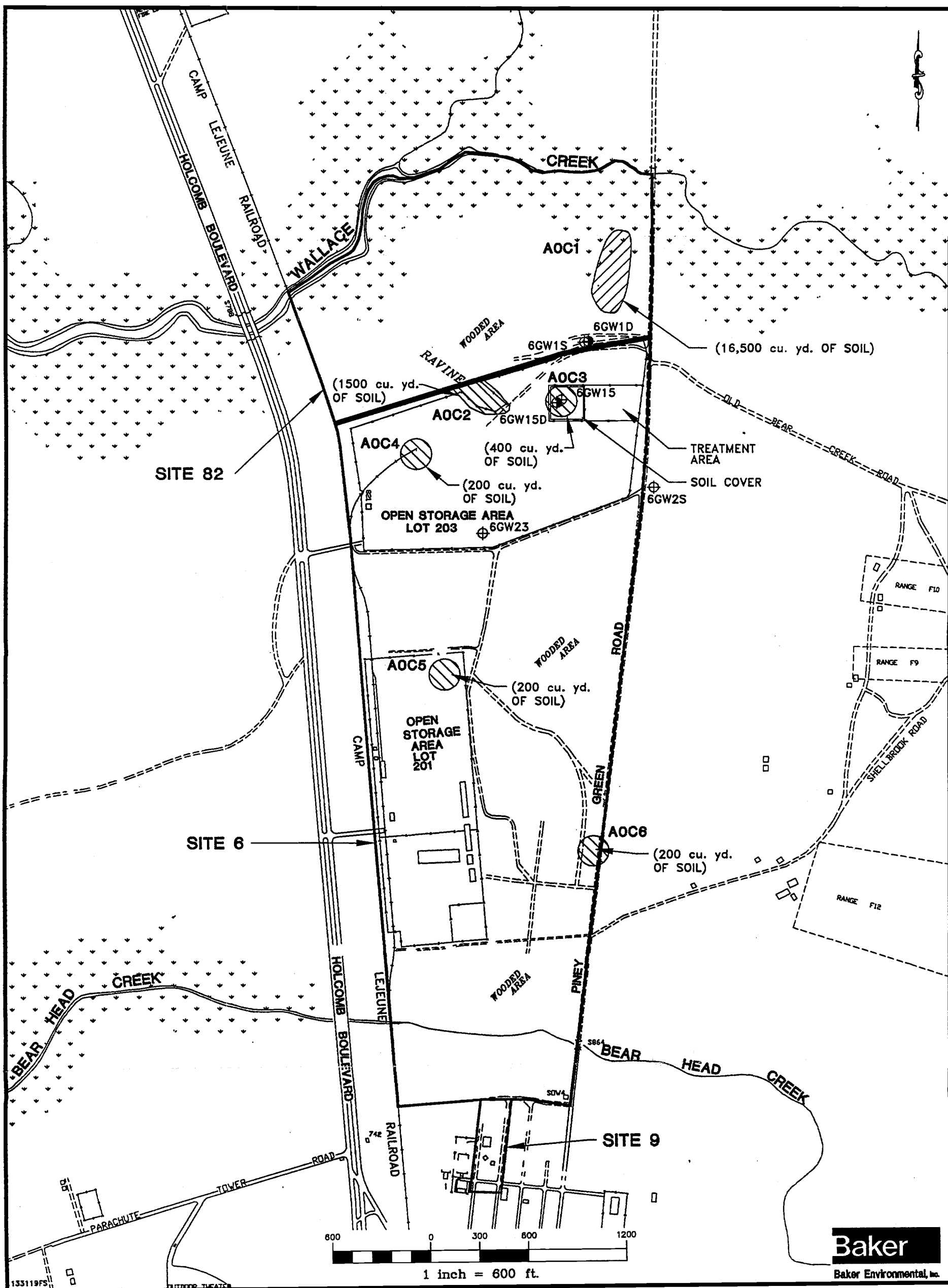

LEGEND	
⊕	6GW23 SHALLOW MONITORING WELL INCLUDED IN MONITORING PROGRAM
⊕	6GW1D DEEP MONITORING WELL INCLUDED IN MONITORING PROGRAM
	AOC1 AREA OF CONCERN WITH SOILS TO BE TREATED
	AOC5 AREA OF CONCERN WITH SOILS TO BE CAPPED

FIGURE 4-15
 SOIL RAA NO. 4:
 CAPPING AND ON-SITE TREATMENT
 FEASIBILITY STUDY CTO-0133
 MARINE CORPS BASE, CAMP LEJEUNE
 NORTH CAROLINA

SOURCE: LANTDIV, FEBRUARY 1992



01483 CC10Z

The contaminated soils within Soil AOCs 1, 2, and 5 will be excavated, placed into dump trucks, transported to the on-site treatment area (or soil staging area). The limits of the excavations will be defined by constituent concentrations in excess of the specified remediation goals. For FS estimating purposes, approximately 18,200 cubic yards of soil will be excavated. Confirmation soil sampling will be conducted during the excavation activities to determine the lateral and vertical extent of each soil excavation. The samples will be analyzed for the specific COCs within each AOC. It should be noted that significantly less excavation will be necessary if in situ volatilization is selected for the VOC-contaminated Soil AOC1.

Prior to any excavation activities, site operating areas for soil staging and for decontamination will be constructed. The staging area will be used for the interim storage of excavated soils prior to treatment, if applicable. During storage periods, the soil will be covered to prevent the potential leaching of contaminants, dust generation, and potential for surface water runoff contamination. The equipment decontamination area will be equipped with a steam cleaning pad with proper containment for rinse water.

Capping - Following excavation activities, a soil cover will be installed over the contaminated soils that are piled within Lot 203. The approximate areal extent of the cap or cover is depicted in Figure 4-15. For the purpose of this FS, the cap will be approximately 200 feet wide by 200 feet long. The contaminated soil will be spread approximately one to two feet thick in the capped area. The cover will consist of 6 inches of topsoil, 18 inches of soil fill, 12 inches of sand, and a geomembrane layer. To ensure the integrity of the capping system, periodic maintenance will be required. In addition, the cap surface will be regularly mowed.

Treatment - Following excavation activities, the contaminated soil from the other Soil AOCs will be transported to the on-site treatment area. Depending on the type of contaminants, different treatment systems may be required at the site. For the purpose of this FS, three treatment technologies/process options have been retained as applicable for the COCs in these soils. They include land treatment, in situ volatilization, and incineration. Refer to Soil RAA No. 3 for a detailed description of each of these treatment technologies. Following treatment, any residual soils will be removed from the treatment unit, analyzed, and if permitted, used as backfill at the site. If not permitted, the treated soils will be properly disposed off site. Note that air emissions will be monitored during all soil remediation activities.

Surface Controls - The excavated areas will be graded to conform to the surrounding terrain. Clean fill may be added to the excavated areas as necessary to bring the areas up to grade. The excavated areas will be revegetated.

Monitoring - In order to monitor the effectiveness of the cap (i.e., the migration of the COCs), groundwater sampling will be conducted semiannually. Groundwater samples will be collected from six monitoring wells: 6GW15, 6GW15D, 6GW1S, 6GW1D, 6GW2S, and 6GW23.

Access Restrictions - The capped area and the treatment area will be fenced to restrict access to these areas and reduce damage to the cover and/or treatment system. The fencing will connect to the existing fence at Lot 203, along the eastern side of the lot. This RAA will require approximately 2,000 linear feet of new chain-link fence to be installed. The fence will be of sufficient height and construction so as to limit access to the cap. In addition, No Trespassing signs will be posted along the fence to further deter access. Routine maintenance and repairs of the fence, as necessary, are also included under this RAA. In addition to the fence, deed restrictions restricting the use of the area in and around Lot 203 will be implemented. Any soil excavated during potential future construction activities will require appropriate disposal in accordance with applicable Federal and State regulations.

In the event that the long-term groundwater monitoring program indicates that the groundwater conditions are deteriorating, other actions will be taken. In addition, since contaminants will remain at the site under this alternative, the USEPA is required by the NCP [40 CFR 300.515(e)(ii)] to review the effects of this alternative no less often than every five years.

4.1.2.5 Soil RAA No. 5: Off-Site Treatment/Disposal

In general, Soil RAA No. 5 includes the excavation and off-site treatment/disposal of the contaminated soils from all of the Soil AOCs. The approximate area of soils to be excavated is the same as for Soil RAA No. 3 (refer to Figure 4-9). As shown on Table 4-2, the technologies/process options included under this RAA include soil excavation, grading, revegetation, and off-site treatment at a permitted facility. The main components of this alternative are described below.

Excavation - The same excavation measures discussed under Soil RAA No. 2 will be implemented with this RAA. The contaminated soils within each Soil AOC will be excavated, placed into dump trucks, transported to an approved off-site treatment facility. The limits of the excavations will be defined by constituent concentrations in excess of the specified remediation goals. For FS estimating purposes, approximately 19,000 cubic yards of soil will be excavated. Confirmation soil sampling will be conducted during the excavation activities to determine the lateral and vertical extent of each soil excavation. The samples will be analyzed for the specific COCs and any other analyses required by the off-site facility (e.g., BTU value, moisture content, metals).

Note that prior to any excavation activities, site operating areas for decontamination will be constructed. The equipment decontamination area will be equipped with a steam cleaning pad with proper containment for rinse water. Air emissions will be monitored during soil remediation activities.

Treatment - Following excavation activities, the soils will be transported to the off-site treatment/disposal facility. Under this alternative, there are no residuals generated that will require additional treatment or management. The off-site facility will have to be capable of treating or disposing PCBs, VOCs, SVOCs, and pesticides. The most limiting contaminant for finding an applicable treatment facility is PCBs. Based on the available data, the levels of PCBs detected at the operable unit are below the limit regulated under TSCA, therefore it may be possible to landfill the soils as nonhazardous. A landfill located in Pinewood, South Carolina may be capable of handling these soils.

If necessary, there are several commercially permitted PCB disposal/treatment companies throughout the United States. Based on the USEPA guidance document, Guidance on Remedial Actions for Superfund Sites with PCB Contamination, the closest commercially-permitted chemical waste landfill is the Chemical Waste Management Emelle, Alabama facility. The closest incinerator companies include: ENSCO in Little Rock, Arkansas; Rollins in Deer Park, Texas; and U.S. Department of Energy/Martin Marietta Energy Systems in Oak Ridge, Tennessee.

Surface Controls - The excavated areas will be graded to conform to the surrounding terrain. Clean fill may be added to the excavated areas as necessary to bring the areas up to grade. The excavated areas will be revegetated.

4.1.2.6 Soil RAA No. 6: Capping and On-Site Treatment
(Limited Areas of Concern)

In general, Soil RAA No. 6 is similar to Soil RAA No 4 with the exception that three of the Soil AOCs will not be included in the scope of this RAA. This RAA includes the excavation and consolidation of the contaminated soils from Soil AOCs 4 and 5 and placement under a soil cover placed within Open Storage Lot 203; and the in situ treatment of the soil from Soil AOC1. As shown in Table 4-2, the technologies/process options included with this RAA include monitoring, deed restrictions, fencing, capping, grading, revegetation, soil excavation, and on-site treatment. Figure 4-16 depicts the approximate areas of soil that will be treated in situ, and also shows the proposed location of the on-site cap.

The rationale for this RAA is based on the existing land use of the operable unit (i.e., military storage areas) and not on a hypothetical future land use scenario (i.e., residential area). Based on the action levels presented in Section 2.0 of this FS, the only AOCs exceeding the action levels for base personnel include AOCs 1, 4, and 5. Therefore, this RAA presents the most realistic approach to remediating these areas. Soil AOC1 will be treated in situ via volatilization. Soil AOCs 4 and 5 will be excavated and placed under a soil cover installed within Lot 203. The main components of this alternative are described below.

Excavation - The same excavation measures discussed under Soil RAA No. 2 will be implemented with this RAA. The only difference will be where the soils are taken. The contaminated soils from Soil AOCs 4 and 5 will be excavated, placed into dump trucks, transported to Lot 203, and piled into the designated cap area. The limits of the excavations will be defined by constituent concentrations in excess of the specified remediation goals. For FS estimating purposes, approximately 200 cubic yards of PCB-contaminated soil (AOC4) and 200 cubic yards of pesticide-contaminated soil (AOC5) will be excavated. Confirmation soil sampling will be conducted during the excavation activities to determine the lateral and vertical extent of each soil excavation. The samples will be analyzed for the specific COCs.

The contaminated soils within Soil AOC1 (approximately 16,500 cubic yards) will be treated in situ via volatilization.

Prior to any excavation activities, site operating areas for soil staging and for decontamination will be constructed. The staging area will be used for the interim storage of excavated soils prior to treatment, if applicable. During storage periods, the soil will be

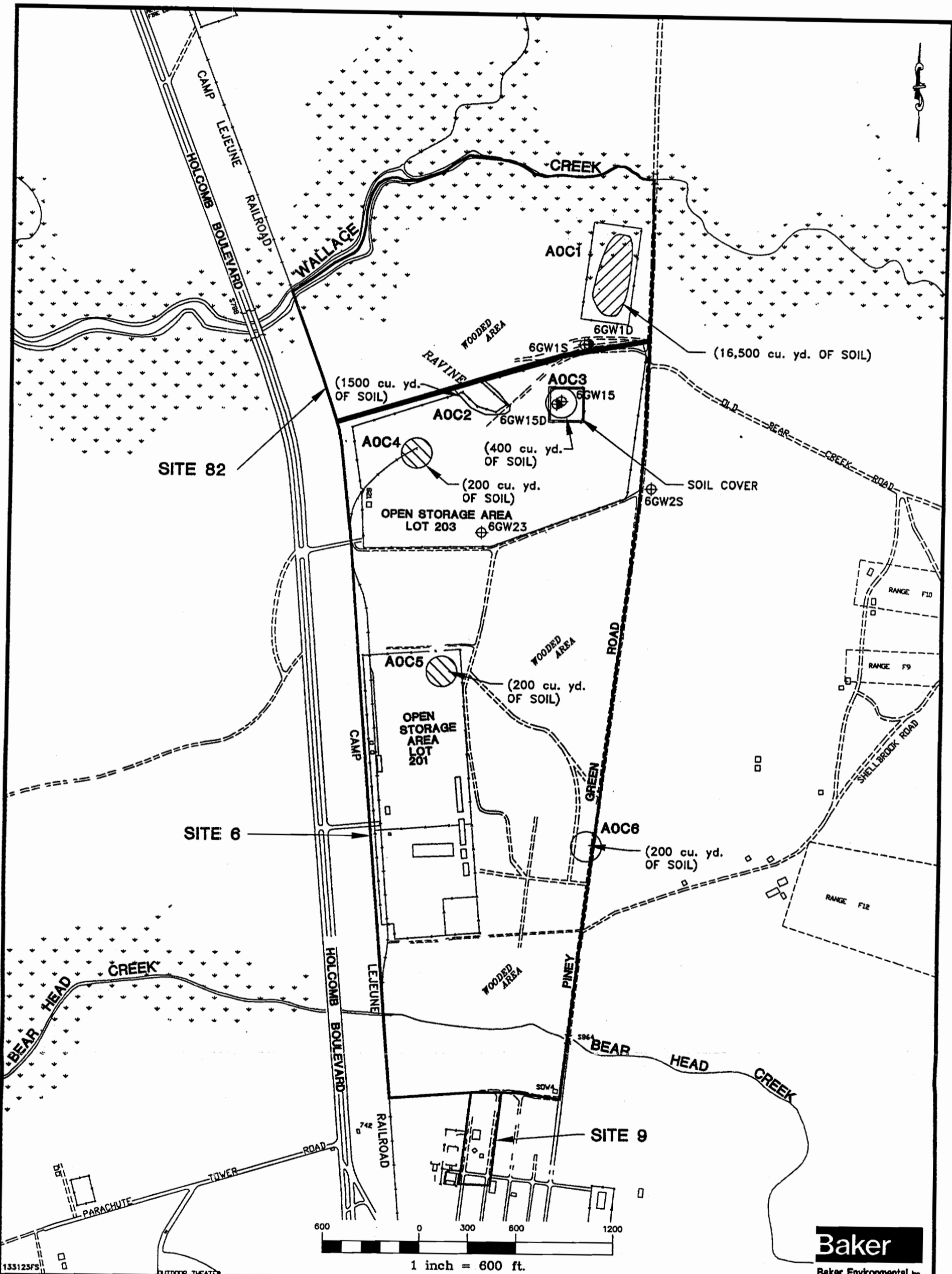

Baker
Baker Environmental, Inc.

LEGEND

- | | |
|--|--|
| <p>6GW23 SHALLOW MONITORING WELL INCLUDED IN MONITORING PROGRAM</p> <p>6GW1D DEEP MONITORING WELL INCLUDED IN MONITORING PROGRAM</p> | <p>AOC1 AREA OF CONCERN WITH SOILS TO BE TREATED</p> <p>AOC5 AREA OF CONCERN WITH SOILS TO BE CAPPED</p> <p>AOC6 AREA OF CONCERN-NO ACTION</p> |
|--|--|

FIGURE 4-16
SOIL RAA NO. 6: CAPPING AND ON-SITE TREATMENT (LIMITED AREAS OF CONCERN)
FEASIBILITY STUDY CTO-0133

MARINE CORPS BASE, CAMP LEJEUNE
NORTH CAROLINA

SOURCE: LANTDIV, FEBRUARY 1992

0148300112

covered to prevent the potential leaching of contaminants, dust generation, and potential for surface water runoff contamination. The equipment decontamination area will be equipped with a steam cleaning pad with proper containment for rinse water.

Capping - Following excavation activities, a soil cover will be installed over the contaminated soils that are piled within Lot 203. The approximate areal extent of the cap or cover is depicted in Figure 4-16. For the purpose of this FS, the cap will be approximately 200 feet wide by 200 feet long. The contaminated soil will be spread approximately one to two feet thick in the capped area. The cover will consist of 6 inches of topsoil, 18 inches of soil fill, 12 inches of sand, and a geomembrane layer. To ensure the integrity of the capping system, periodic maintenance will be required. In addition, the cap surface will be regularly mowed.

Treatment - The contaminated soil from Soil AOC1 will be treated via in situ volatilization since the primary COCs within this AOC are VOCs. Refer to Soil RAA No. 3 for a detailed description of this technology. Air emissions will be monitored during soil remediation activities.

Surface Controls - Clean fill may be added to any disturbed areas as necessary to bring the areas up to grade. The disturbed areas will be revegetated.

Monitoring - In order to monitor the effectiveness of the cover (i.e., the migration of the COCs), groundwater sampling will be conducted semiannually. Groundwater samples will be collected from six monitoring wells: 6GW15, 6GW15D, 6GW1S, 6GW1D, 6GW2S, and 6GW23.

Access Restrictions - The capped area and the treatment area will be fenced to restrict access to these areas and reduce damage to the cap and/or treatment system. The fencing will connect to the existing fence at Lot 203, along the eastern side of the lot. This RAA will require approximately 1,000 linear feet of new chain-link fence to be installed. The fence will be of sufficient height and construction so as to limit access to the cap. In addition, No Trespassing signs will be posted along the fence to further deter access. Routine maintenance and repairs of the fence, as necessary, are also included under this RAA. In addition to the fence, deed restrictions restricting the use of the area in and around Lot 203 will be implemented. Any soil excavated during potential future construction activities will require appropriate disposal in accordance with applicable Federal and State regulations.

In the event that the long-term groundwater monitoring program indicates that the groundwater conditions are deteriorating, other actions will be taken. In addition, since contaminants will remain at the site under this alternative, the USEPA is required by the NCP [40 CFR 300.515(e)(ii)] to review the effects of this alternative no less often than every five years.

4.1.2.7 Soil RAA No. 7: On-Site Treatment and Off-Site Disposal

Soil RAA No. 7 includes the on-site treatment of VOC-contaminated soil (AOC1) via in situ volatilization and the off-site disposal of the soils from the remaining soil AOCs. As shown in Table 4-2, the technologies/process options included under this RAA are monitoring, deed restrictions, fencing, grading, revegetation, soil excavation, on-site treatment, and off-site treatment/disposal. Figure 4-17 depicts the approximate areas of soil to be excavated and the proposed location of the on-site treatment area. A description of each of the main components of the RAA follow.



Excavation - The soils from AOCs 2 through 6 will be excavated and placed into dump trucks designed for off-site transporting. The limits of the excavations will be defined by constituent concentrations in excess of the remediation goals. For FS estimating purposes, approximately 2,500 cubic yards of soil will be excavated under this RAA. This total is based on 1,500 cubic yards from AOC2, 400 cubic yards from AOC3, and 200 cubic yards each from AOCs 4, 5, and 6. The soils from AOC1 will not be excavated under this RAA. Confirmation soil sampling will be conducted during the excavation activities to determine the lateral and vertical extent of each soil excavation. The samples will be analyzed for the specific COCs and any other analyses required by the off-site disposal facility.

Prior to any excavation activities, site operating areas for decontamination will be constructed. The equipment decontamination area will be equipped with a steam cleaning pad with proper containment for rinse water.

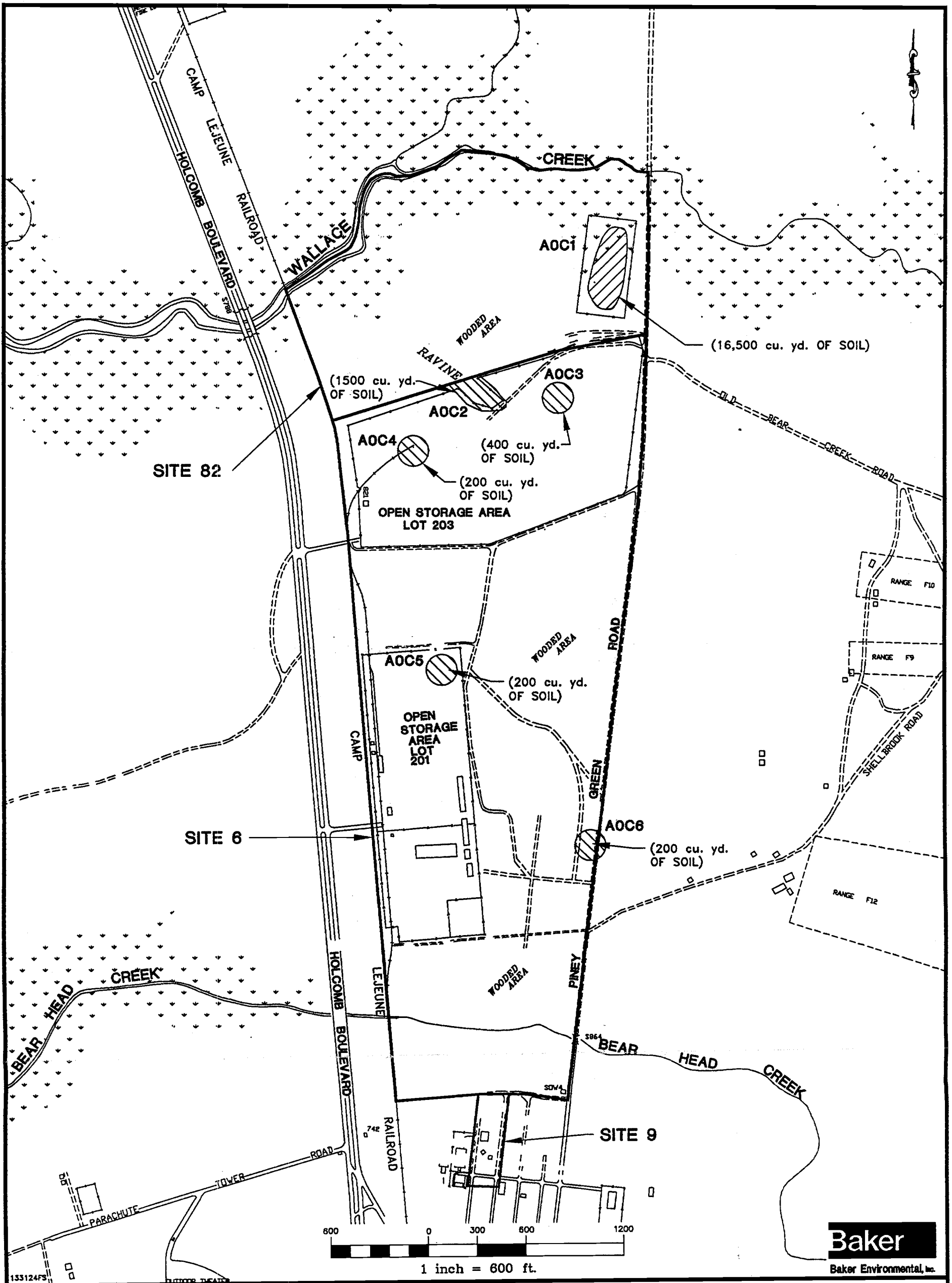
Off-Site Disposal - Following excavation activities, the soils will be transported to the off-site disposal facility. There will be no residuals generated from AOCs 2 through 6 that will require additional treatment or management. Based on the low levels of the PCBs (less than 50 mg/kg) detected in the soils from the AOCs, the excavated soils should be able to be considered as nonhazardous waste. A landfill located in Pinewood, South Carolina, should be



4-44

- LEGEND**
-  AOC1 SOILS TO BE TREATED VIA IN SITU VOLATILIZATION
 -  AOC5 SOILS TO BE EXCAVATED AND REMOVED

SOURCE: LANTDIV, FEBRUARY 1992

FIGURE 4-17
SOIL RAA NO. 7: ON-SITE TREATMENT AND OFF-SITE DISPOSAL FEASIBILITY STUDY CTO-0133

MARINE CORPS BASE, CAMP LEJEUNE
 NORTH CAROLINA



01483CC122

capable of disposing of these soils. This facility is located approximately 200 miles from the Operable Unit.

On-Site Treatment - The soils within Soil AOC1 will be treated via in situ volatilization. Refer to Soil RAA No. 3 for a description of this treatment technology. Confirmation soil sampling will be conducted to identify the edge of the area to be treated. Vapor extraction wells will be installed above the water table. The number and location of the extraction wells will be determined during the predesign stage (pilot study results). The extracted vapors will be treated on site. The residuals generated from the vapor treatment system will be properly disposed off site. Air emissions will be monitored during soil remediation activities.

Surface Controls - The excavated areas will be graded to conform to the surrounding terrain. Clean fill may be added to the excavated areas as necessary to bring the areas up to grade. The excavated areas and any disturbed areas will be revegetated.

Monitoring - In order to determine the effectiveness of the in situ treatment system, soil sampling will be conducted semiannually. Approximately ten samples will be collected during each sampling event and analyzed for VOCs. The treatment will be considered complete once the soil remediation goals are reached and maintained.

Access Restrictions - The treatment area will be fenced to restrict access and reduce damage to the in situ system. This RAA will require approximately 1,600 linear feet of new chain-link fence to be installed. The fence will be of sufficient height and construction so as to limit access to the cap. In addition, No Trespassing signs will be posted along the fence to further deter access. Routine maintenance and repairs of the fence, as necessary, are also included under this RAA. In addition to the fence, deed restrictions restricting the use of the area in and around Site 82 will be implemented. Any soil excavated during potential future construction activities will require appropriate disposal in accordance with applicable Federal and State regulations.

In the event that the long-term soil monitoring program indicates that the soil conditions are deteriorating, other actions will be taken. In addition, since contaminants will remain at the site under this alternative, the USEPA is required by the NCP [40 CFR 300.515(e)(ii)] to review the effects of this alternative no less often than every five years.

4.2 Screening of Alternatives

Typically, this Section of the FS presents the initial screening of the potential RAAs. The objective of this screening is to make comparisons between similar alternatives, so that only the most promising ones are carried forward for further evaluation (USEPA, 1988a). This screening is an optional step in the FS process, and is usually conducted if there are too many RAAs to conduct the detailed evaluation on. For OU No. 2, the decision was made not to conduct this preliminary RAA screening step, and to include all of the developed RAAs in the detailed evaluation presented in Section 5.0.

5.0 DETAILED ANALYSIS OF ALTERNATIVES

This section of the FS contains the detailed analysis of the set of RAAs developed in Section 4.0. This analysis has been conducted to provide sufficient information to adequately compare the alternatives, select an appropriate remedy for the site, and demonstrate satisfaction of the CERCLA remedy selection requirements in the Record of Decision (ROD) (USEPA, 1988a).

The extent to which alternatives are assessed during this detailed analysis is influenced by the available data, the number and types of alternatives being analyzed, and the degree to which alternatives were previously analyzed during their development (USEPA, 1988a).

The following nine evaluation criteria serve as the basis for conducting the detailed analysis:

1. Overall protection of human health and the environment;
2. Compliance with ARARs;
3. Long-term effectiveness and permanence;
4. Reduction of toxicity, mobility, or volume;
5. Short-term effectiveness;
6. Implementability;
7. Cost;
8. USEPA/State acceptance; and
9. Community acceptance.

The first two criteria (Threshold Criteria) relate directly to statutory findings; the next five criteria (Primary Balancing Criteria) are the primary criteria upon which the analysis is based; and the final two criteria (Modifying Criteria) are typically evaluated following comment on the RI/FS report and the Proposed Remedial Action Plan (PRAP).

5.1 Individual Analysis of Alternatives

The individual analysis of the RAAs is presented in the following subsections. This analysis includes an assessment and a summary profile of each of the RAAs against the evaluation criteria, and a comparative analysis among the alternatives to assess the relative performance of each with respect to each of the evaluation criterion.

The cost estimates that have been developed for each of the alternatives include both capital and operational expenditures. The cost evaluation presents the net present worth (NPW) values for each of the alternatives such that the options can be easily compared. The accuracy of each cost estimate depends upon the assumptions made and the availability of costing information. The present worth costs were calculated assuming a 30-year operational period (based on USEPA guidance) for all of the alternatives, a five percent discount factor, and a zero percent inflation rate. All costs presented in the following sections have been updated to 1993 dollar values. The individual cost estimates are included in Appendix C.

5.1.1 Groundwater RAAs

5.1.1.1 Groundwater RAA No. 1: No Action

Description

Under the Groundwater RAA No. 1, the groundwater in the aquifer at the operable unit will remain as is. Under this alternative, the contaminants identified in the shallow and deep portions of the aquifer will remain, which will result in the potential for further migration of the contaminated plumes. Aquifer restoration may result through natural processes such as biological degradation, attenuation, and dispersion.

Assessment

Overall Protection of Human Health and the Environment

Under this alternative, the existing contamination in the groundwater aquifer (both shallow and deep portions) will have the potential for further migration both horizontally and vertically. Therefore, this alternative does not provide for any protection to human health or the environment.

Compliance With ARARs

Under the No Action RAA, the groundwater quality in the aquifer will continue to exceed the Federal and/or North Carolina contaminant-specific ARARs established for the COCs. No action-specific or location-specific ARARs apply to this RAA.

Long-Term Effectiveness and Permanence

In terms of the magnitude of residual risks remaining at the operable unit, this alternative will not reduce any potential risks present at the sites with respect to the contaminants in the groundwater. In time, natural bacteriological attenuation may lessen the potential for risks.

In terms of the adequacy and reliability of controls used to manage treatment residuals or untreated wastes that will remain at the operable unit, the No Action RAA does not include any type of controls for the remaining contamination. Therefore, this RAA is not considered reliable.

The No Action RAA would require EPA's 5-year review to ensure that adequate protection of human health and the environment is maintained.

Overall, the Groundwater RAA No. 1 can not be considered as an effective or permanent RAA.

Reduction of Toxicity, Mobility, or Volume

No form of treatment is included under the No Action RAA (with the exception of natural biodegradation). Therefore, a very limited amount of the contaminants in the groundwater aquifer will be destroyed or treated. This RAA does not satisfy the statutory preference for treatment.

Short-Term Effectiveness

Since there are no remedial action activities associated with RAA No. 1, the risks to the community are not increased by the implementation of this RAA. In addition, there are no significant risks to workers with respect to implementation. The current impacts to the environment from the existing conditions will continue. The time required to meet the remedial response objectives can not be estimated.

Implementability

With respect to technical implementability, RAA No. 1 is the easiest alternative to implement since there are no construction or operation activities. In addition, this RAA does not include any actions to monitor its effectiveness. In terms of administrative feasibility, this alternative

should not require coordination with other agencies (i.e., no permits are necessary). The availability of services, materials, and/or technologies is not applicable to this alternative.

Cost

There are no capital costs or O&M costs associated with this alternative. Therefore, the NPW is \$0.

USEPA/State Acceptance

To be addressed following USEPA/NC DEHNR review of the ROD

Community Acceptance

To be addressed following the public comment period

5.1.1.2 Groundwater RAA No. 2: Limited Action

Description

Under Groundwater RAA No. 2, only limited actions including long-term groundwater monitoring, aquifer-use restrictions, and deed restrictions will be included. Aquifer restoration may occur through natural processes such as biological degradation, attenuation, and dispersion. The RAA will include semiannually sampling and analysis of groundwater from nine deep monitoring wells, twelve shallow monitoring wells, and three local supply wells. The wells will be analyzed for TCL volatile organics (Level III data quality). Aquifer-use restrictions will be placed on the two currently closed local supply wells. In addition, deed restrictions will be placed restricting the installation of any new wells within the vicinity of OU No. 2.

Assessment

Overall Protection of Human Health and the Environment

Under this RAA, the existing contamination in the groundwater aquifer will have the potential for further migration both horizontally and vertically. Currently, two supply wells

in the area of contamination are not operating. Supply wells located outside the area of contamination are monitored periodically by the base and are not contaminated.

If the aquifer-use restrictions and deed restrictions are strictly enforced, and monitoring of the plume and operational supply wells is implemented, this RAA will provide protection to human health with a reduction in the potential for groundwater ingestion. This RAA allows continued contamination of the groundwater, therefore, it provides little, if any, protection to the environment.

Compliance With ARARs

Under RAA No. 2, the groundwater quality in the aquifer will exceed the Federal and/or North Carolina contaminant-specific ARARs established for the COCs. No action-specific or location-specific ARARs apply to this RAA.

Long-Term Effectiveness and Permanence

In terms of the magnitude of residual risks remaining at the operable unit, this RAA will reduce the risks to human health since the use of the groundwater as a potable water source near the sites will be restricted. Risks would remain under this RAA if the groundwater at the site was used as a drinking water source without treatment.

The adequacy and reliability of the controls included under this RAA (i.e., aquifer-use and deed restrictions) is effective. If strictly enforced, these controls will reduce the risks associated with the ingestion of the contaminated groundwater. If not strictly enforced, these controls would not be adequate.

RAA No. 2 would require EPA's 5-year review to ensure that adequate protection of human health and the environment is maintained.

Reduction of Toxicity, Mobility, or Volume

No form of treatment is included under RAA No. 2 (with the exception of natural biodegradation). Therefore, a very limited amount of the contaminants in the groundwater aquifer will be destroyed or treated. This RAA does not satisfy the statutory preference for treatment.

Short-Term Effectiveness

Since there are only administrative activities associated with RAA No. 2, the risks to the community (base personnel) are not increased by the implementation of this RAA. In addition, there are no significant risks to workers. The current impacts to the environment from the existing conditions will continue. Under this RAA, the potential risks associated with contaminated groundwater will be reduced due to institutional controls within 3 to 6 months.

Implementability

With respect to technical implementability, RAA No. 2 is easy to implement since the only activities are administrative or involve groundwater monitoring. The monitoring wells already have been installed at the sites. The proposed monitoring will indicate if the groundwater quality is significantly deteriorating. In terms of administrative feasibility, this alternative should not require coordination with other agencies following the ROD (i.e., no approvals of permits or other actions are necessary). The required sampling equipment and materials are readily available.

Cost

There are minimal capital costs associated with RAA No. 2. Annual O&M cost of approximately \$39,000 are projected for the groundwater monitoring program. Assuming a monitoring period of 30 years and an annual percentage rate of five percent, the NPW of this RAA is approximately \$600,000.

USEPA/State Acceptance

Since this alternative does not remove or destroy the COCs, and may ultimately endanger other drinking water supply wells, the USEPA and State are not expected to favor this alternative.

Community Acceptance

It is unlikely that the community will support any form of a No Action Alternative.

5.1.1.3 Groundwater RAA No. 3: Containment

Description

In general, RAA No. 3 includes the containment of the contaminated plumes via extraction and treatment. In addition, this RAA includes the same institutional controls as Groundwater RAA No.2 (Limited Action). The objective of this RAA is to reduce or eliminate the potential for further migration of the existing groundwater contaminant plumes at the operable unit. A series of deep and shallow extraction wells will be installed along the boundaries of the shallow and deep plumes. The extracted groundwater will be treated on site via a combination of several treatment technologies including metals removal, air stripping, and carbon adsorption. Treated water will be discharged to Wallace Creek.

The RAA will include semiannually sampling and analysis (TCL volatile organics) of groundwater from nine deep monitoring wells, twelve shallow monitoring wells, and three local supply wells. Aquifer-use restrictions will be placed on the two currently closed local supply wells. In addition, deed restrictions will be placed restricting the installation of any new wells within the vicinity of OU No. 2.

Assessment

Overall Protection of Human Health and the Environment

Under this RAA, the migration of the contaminated plume will be mitigated, further reducing the potential risks associated with groundwater exposure (via operating supply wells). If the aquifer-use restrictions, deed restrictions, and monitoring program are strictly enforced, this RAA will provide additional reduction in the potential for groundwater ingestion. This RAA reduces the continued migration of the contaminant plume, therefore, it provides protection to the environment.

Compliance With ARARs

Under RAA No. 3, the groundwater quality in the aquifer will be improved at the initiation of the groundwater pump and treat system. The Federal and/or North Carolina contaminant-specific ARARs established for the COCs will not likely be met for the contaminated

groundwater under this RAA due to both hydrogeologic factors (e.g., subsurface heterogeneity, low permeability, and discontinued layers) and contaminant factors (e.g., partitioning of contaminants between groundwater and aquifer solids). Location-specific ARARs are not applicable to this alternative. Action-specific ARARs such as NPDES and air emission permits may apply to this RAA.

Long-Term Effectiveness and Permanence

In terms of the magnitude of residual risks remaining at the operable unit, this RAA will reduce the risks to human health for the following reasons: (1) the migration of the contaminant plume is mitigated, and (2) the use of the groundwater as a potable water source near the sites is restricted. Following the completion of this RAA, there should be low residual risks remaining at the operable unit with respect to the contaminated groundwater.

The source removal activities under this RAA are reliable and adequate. Groundwater pump and treat methods are both adequate and reliable to some extent. All of the technologies/process options are proven and commercially used. As with most equipment, there is a potential for replacement and/or repairs. The adequacy and reliability of the institutional controls are effective.

Since this RAA is not designed to be a complete contaminant removal option, it will require EPA's 5-year review to ensure that adequate protection of human health and the environment is maintained.

Reduction of Toxicity, Mobility, or Volume

Under this RAA, the groundwater within the outer boundaries of the contaminant plume will be treated via a treatment system consisting of, but not limited to, air stripping, carbon adsorption, and metals removal. This RAA is designed to reduce the mobility of the contaminants in the groundwater. This RAA satisfies the statutory preference for treatment.

Short-Term Effectiveness

The risks to the community/base personnel will be slightly increased due to a temporary increase in dust production and volatilization during the installation of underground piping for the groundwater treatment system. It should be noted that the closest military operation

near this action is at Lot 201, which is approximately one-half mile south of this area. Workers will require additional protection during the installation and operation of the groundwater treatment system. Environmental impacts will include aquifer draw down during groundwater extraction. With respect to time to complete the remedial action, the groundwater pump and treat system will be operated for many years, and the contaminant plumes may not ever be completely remediated due to the thickness and horizontal characteristics of the aquifer. For FS purposes, 30 years has been estimated.

Implementability

With respect to technical implementability, the groundwater pump and treat system will require operation. If necessary, the extraction system would be relatively easy to expand with the addition of extraction wells and piping. The monitoring wells have already been installed at the sites. The proposed monitoring will indicate if the groundwater quality is significantly deteriorating or improving as a result of this action. In terms of administrative feasibility, this alternative may require an NPDES permit or permission for discharge into Wallace Creek. This RAA requires treatment plant operators.

Cost

The capital costs associated with RAA No. 3 are estimated to be \$2.6 million. O&M cost are approximately \$285,000 annually are projected for the operation of the extraction/treatment system and the groundwater monitoring program. Assuming a monitoring period of 30 years and an annual percentage rate of five percent, the NPW of this RAA is approximately \$7.0 million. Refer to Appendix C for the cost estimate for this RAA.

USEPA/State Acceptance

Since this RAA does not remove or destroy the COCs, the USEPA and State are not expected to favor this alternative.

Community Acceptance

It is unlikely that the community will support any form of a limited action alternative.

5.1.1.4 Groundwater RAA No. 4: Intensive Groundwater Extraction and Treatment

Description

In general, RAA No. 4 includes the treatment of the contaminant plumes at the area with the highest level of contamination. This area is primarily located at Site 82, east of the ravine and west of Piney Green Road. This RAA will include a series of deep and shallow extraction wells located in the most contaminated areas of the sites. The extracted groundwater will be treated on site and then discharged to Wallace Creek. In addition, this RAA includes the same institutional controls as Groundwater RAA Nos. 2 and 3. The objective of this RAA is to eliminate the "most contaminated" areas of the groundwater contamination. This area acts as a source of surface water contamination at Wallace Creek, in addition to being the source of off-site groundwater contamination. Over time, the entire plume will be remediated to meet the remediation goals.

The RAA will include semiannual sampling and analysis of groundwater from nine deep monitoring wells, twelve shallow monitoring wells, and three local supply wells (TCL volatile organics). Aquifer-use restrictions will be placed on the two currently closed local supply wells. In addition, deed restrictions will be placed restricting the installation of any new wells within the vicinity of OU No. 2.

Assessment

Overall Protection of Human Health and the Environment

Under this RAA, the most contaminated groundwater (i.e., source areas) will be collected (via extraction wells) and treated, further reducing the potential risks associated with further groundwater degradation. Over time, the downgradient edge of the plume is expected to be captured by the cone of influence produced by the extraction wells. If the aquifer-use restrictions, deed restrictions, and monitoring program are strictly enforced, this RAA will provide additional reduction in the potential for groundwater ingestion. This RAA reduces the continued contamination of the groundwater via source removal, therefore, it provides protection to the environment. Over time, the groundwater may be restored for future beneficial use.

Compliance With ARARs

Under RAA No. 4, the groundwater quality in the aquifer will be improved at the initiation of the groundwater pump and treat system. The Federal and/or North Carolina contaminant-specific ARARs established for the COCs in groundwater may be met under this RAA over time. The timeframe to reach the remediation goals cannot be determined due to the magnitude of the problem and the complexity of the hydrogeologic characteristics. ARARs associated with effluent levels from the treatment system are expected to be met. Location-specific ARARs are not applicable to this alternative. Action-specific ARARs such as NPDES and air emission permits will apply to this RAA.

Long-Term Effectiveness and Permanence

In terms of the magnitude of residual risks remaining at the operable unit, this RAA will reduce the risks to human health for the following reasons: (1) the most contaminated groundwater will be treated, (2) the use of the groundwater as a potable water source near the sites will be restricted, and (3) the operating supply wells in the area will be monitored. Following the completion of this RAA, there will likely be low residual risks remaining at the operable unit with respect to using the aquifer at OU No. 2 as a potable supply.

The source removal activities under this RAA are reliable and adequate. Groundwater pump and treat methods are both adequate and reliable to some extent. All of the technologies/process options are proven for treating the groundwater. Technologies for completely extracting the contaminants from the groundwater are not proven (considering that contaminants may continue to leach from solids to groundwater below the vadose zone). At best, the technologies for extracting contaminated groundwater are reliable from the standpoint of collecting the water, but are not reliable for mitigating groundwater degradation due to the partitioning of contaminants in the water column (below the vadose zone). As with most equipment, there is a potential for replacement and/or repairs. The adequacy and reliability of the institutional controls are effective.

Since this RAA is expected to take many years to reach the remediation goals, it would require EPA's 5-year review to ensure that adequate protection of human health and the environment is maintained.

Reduction of Toxicity, Mobility, or Volume

Under this RAA, groundwater will be treated via a treatment system consisting of, but not limited to, air stripping, carbon adsorption, and metals removal. This RAA is designed to reduce the toxicity, mobility, and volume of the contaminants in the groundwater. This RAA satisfies the statutory preference for treatment.

Short-Term Effectiveness

The risks to the community will be slightly increased due to a temporary increase in dust production and volatilization during the installation of underground piping for the groundwater treatment system. Workers will require additional protection during the installation and operation of the groundwater treatment system. Environmental impacts will include aquifer draw down during groundwater extraction. No significant impacts to Wallace Creek are anticipated due to the aquifer drawdown or discharging the effluent into Wallace Creek. With respect to time to complete the remedial action, the groundwater pump and treat system will be operated for many years, prior to achieving complete groundwater restoration. For costing purposes, 30 years of operation has been estimated.

Implementability

With respect to technical implementability, the groundwater pump and treat system will require operation. If necessary, the extraction system would be easy to expand. The monitoring wells have already been installed at the sites. The proposed monitoring program will indicate if the groundwater quality is significantly deteriorating. In terms of administrative feasibility, this alternative may require an NPDES permit or permission for other discharge. This RAA requires treatment plant operators.

Cost

The capital costs associated with RAA No. 4 are estimated to be \$1.4 million. O&M cost are approximately \$230,000 annually are projected for the operation of the extraction/treatment system and the groundwater monitoring program. Assuming a monitoring period of 30 years and an annual percentage rate of five percent, the NPW of this RAA is approximately \$4.9 million. Refer to Appendix C for the cost estimate for this RAA.

USEPA/State Acceptance

Since this alternative removes and treats the COCs, it is expected that both USEPA and the State will be in favor of this alternative.

Community Acceptance

It is expected that the community will be in favor of this type of alternative since the COCs are to be removed and treated.

5.1.1.5 Groundwater RAA No. 5: Groundwater Extraction and Treatment

Description

In general, RAA No. 5 includes the treatment of the entire plume of groundwater contamination. In addition, this RAA includes the same institutional controls as Groundwater RAA Nos. 2, 3, and 4. The objective of this RAA is to reduce the the contaminants in the groundwater to drinking water standards for a Class I aquifer, and to mitigate the further migration of the existing groundwater plumes.

The RAA will include semiannual sampling and analysis (TCL volatile organics) of groundwater from nine deep monitoring wells, twelve shallow monitoring wells, and three local supply wells. Aquifer-use restrictions will be placed on the two currently closed local supply wells. In addition, deed restrictions will be placed restricting the installation of any new wells within the vicinity of OU No. 2.

Assessment

Overall Protection of Human Health and the Environment

Under this RAA, the contaminated groundwater will be removed and treated, reducing the potential risks associated with groundwater degradation in supply wells. If the aquifer-use restrictions, deed restrictions, and monitor program are strictly enforced, this RAA will provide additional reduction in the potential for groundwater degradation. This RAA reduces the continued contamination of the groundwater via contaminant removal, therefore, it provides protection to the environment.

Compliance With ARARs

Under RAA No. 5, the groundwater quality in the aquifer will be improved at the initiation of the groundwater pump and treat system. The Federal and/or North Carolina contaminant-specific ARARs established for the effluent discharge will potentially be met under this RAA in time. ARARs associated with Class I groundwater quality will be met over time. The timeframe to achieve the remediation goals is difficult to estimate. due to the magnitude of the groundwater contamination, and the hydrogeologic complexity of the site. Location-specific ARARs are not applicable to this alternative. Action-specific ARARs such as NPDES and air emission permits may apply to this RAA.

Long-Term Effectiveness and Permanence

In terms of the magnitude of residual risks remaining at the operable unit, this RAA will reduce the risks to human health for the following reasons: (1) the contaminated groundwater will be treated, (2) the use of the groundwater as a potable water source near the sites is restricted, and (3) existing supply wells will be monitored.

The source removal activities under this RAA are reliable and adequate. Groundwater pump and treat methods are both adequate and reliable for extracting and treating the groundwater, but not for recovering all groundwater contaminants that would be present via partitioning between groundwater and aquifer solids. All of the technologies/process options for treating the effluent are proven and commercially used. As with most equipment, there is a potential for replacement and/or repairs. The adequacy and reliability of the institutional controls are uncertain.

Since this RAA will take several years to meet the remediation goals, it will require EPA's 5-year review to ensure that adequate protection of human health and the environment is maintained.

Reduction of Toxicity, Mobility, or Volume

Under this RAA, the groundwater within the contaminant plume will be treated via a treatment system consisting of, but not limited to, air stripping, carbon adsorption, and metals

removal. This RAA is designed to reduce the toxicity, mobility, and volume of the contaminants in the groundwater. This RAA satisfies the statutory preference for treatment.

Short-Term Effectiveness

The risks to the community will be slightly increased due to a temporary increase in dust production and volatilization during the installation of underground piping for the groundwater treatment system. Workers will require additional protection during the installation and operation of the groundwater treatment system. Environmental impacts will include aquifer draw down during groundwater extraction. No significant impacts to Wallace Creek are anticipated with the drawdown of the aquifer. With respect to time to complete the remedial action, the groundwater pump and treat system will be operated for many years. For costing purposes, 30 years has been estimated.

Implementability

With respect to technical implementability, the groundwater pump and treat system will require operation. If necessary, the extraction system would be easy to expand. The monitoring wells associated with long-term monitoring already have been installed at the sites. The proposed monitoring will indicate if the groundwater quality is significantly deteriorating, or improving.

Once in operation, the treatment systems will require maintenance. Items of concern would be the extraction pumps, the pretreatment system, the air stripper, the carbon units, and spent carbon. Time would be required in this alternative for the removal and replacement of spent carbon.

In terms of administrative feasibility, this alternative would require coordination with other agencies for possible NPDES and air permits. No problems are anticipated with the availability of any of the required equipment, laboratory services, or associated materials.

Cost

The capital costs associated with RAA No. 5 are estimated to be \$3.5 million. O&M cost are approximately \$350,000 annually are projected for the operation of the extraction/treatment system and the groundwater monitoring program. Assuming a monitoring period of 30 years

and an annual percentage rate of five percent, the NPW of this RAA is approximately \$8.9 million. Refer to Appendix C for the cost estimate for this RAA.

USEPA/State Acceptance

Since this alternative removes and treats the COCs, it is expected that USEPA and the State will be in favor of this RAA.

Community Acceptance

It is expected that the community will be in favor of this RAA since the groundwater COCs will be removed and treated.

5.1.2 Soil RAAs

The detailed evaluation of the seven soil RAAs is presented below. Soil RAAs 1 through 5, and 7 address future use of the site for residential and Soil RAA 6 considers the future use of the site as an open storage area. It should be noted that soils from Site 9 did not exceed the remediation goals.

5.1.2.1 RAA No. 1: No Action

Description

Under Soil RAA No. 1 no remedial actions will be performed to reduce the toxicity, mobility, or volume of contaminants in the soil at OU No. 2. The No Action RAA is required by the NCP to provide a baseline for comparison with other soil alternatives that provide a greater level of response. Soil RAA No. 1 involves leaving the contaminated soils which exceed the remediation goals in place.

Assessment

Overall Protection of Human Health and the Environment

Under this alternative, the existing contamination in the soil that exceeds the remediation goals will have the potential for further migration both horizontally and vertically. Therefore, this alternative does not provide for any protection to human health or the environment.

Compliance With ARARs

Under the No Action Alternative, the soils will potentially exceed the TSCA ARAR established for PCBs in soils (for residential areas) in addition to exceeding the risk-based remediation goals established for this OU. No action-specific or location-specific ARARs apply to this alternative.

Long-Term Effectiveness and Permanence

In terms of the magnitude of residual risks remaining at the operable unit, this alternative will not reduce any potential risks present at the sites with respect to the contaminants in the soils.

In terms of the adequacy and reliability of controls used to manage treatment residuals or untreated wastes that will remain at the operable unit, Soil RAA No. 1 does not include any type of controls.

Soil RAA No. 1 will require EPA's 5-year review to ensure that adequate protection of human health and the environment is maintained.

Reduction of Toxicity, Mobility, or Volume

No form of treatment is included under the No Action Alternative. Therefore, no soils are expected to be destroyed or reduced under this RAA. This RAA does not satisfy the statutory preference for treatment.

Short-Term Effectiveness

Since there are no remedial action activities associated with RAA No. 1, the risks to the community are not increased by the implementation of this RAA. In addition, there are no significant risks to workers. The current impacts from the existing conditions to the environment will continue. The time required to meet the remedial response objectives can not be estimated.

Implementability

With respect to technical implementability, RAA No. 1 is the easiest alternative to implement since there are no construction or operation activities. This RAA does not include actions to monitor its effectiveness. In terms of administrative feasibility, this alternative should not require coordination with other agencies following the ROD (i.e., no approvals are necessary). The availability of services, materials, and/or technologies is not applicable to this alternative.

Cost

There are no capital costs or O&M costs associated with this alternative. Therefore, the NPW is \$0.

USEPA/State Acceptance

Since this RAA does not remove or destroy the soil COCs, the USEPA and the State are not expected to favor this alternative.

Community Acceptance

It is unlikely that the community will support any form of a No Action RAA.

5.1.2.2 Soil RAA No. 2: Capping

Description

In general, Soil RAA No. 2 includes the excavation and consolidation of the soils from all of the Soil AOCs and placement under a multilayered cap placed within Open Storage Lot 203. The

cap will consist of layers of top soil, soil fill, geomembrane, sand, gravel, and clay. The technologies/process options included with this RAA include monitoring, deed restrictions, fencing, capping, grading, revegetation, and soil excavation. The principal objectives of this RAA are to consolidate the contaminated soils into one area, to prevent the potential for direct physical contact with the contaminated soils, and to prevent the potential for the migration of contaminants by infiltration and overland transport.

Assessment

Overall Protection of Human Health and the Environment

Soil RAA No. 2 provides protection to human health and to the environment in the form of reducing the potential for direct contact with the contaminated soil and reducing (to a limited extent) the mobility of the contaminated soil. Excavation of contaminated soil will result in eliminating continued degradation of groundwater quality.

Compliance With ARARs

Under this alternative, contaminated soil exceeding the remediation goals will remain at the operable unit, but they will not be treated. Therefore, the contaminant-specific ARARs will not be met. The capped area will be located above the 100-year flood plain, therefore, the location-specific ARAR will be met.

Long-Term Effectiveness and Permanence

As long as the cap is maintained, potential risks due to exposure and migration to the contaminated soils is reduced. Because the contaminated soil is only contained, the inherent hazards related to the contamination still exist to some degree under this RAA. However, the cap can be both adequate and reliable if it is maintained.

Since the contaminated soils will remain on site, Soil RAA No. 2 will require EPA's 5-year review to ensure that adequate protection of human health and the environment is maintained.

Reduction of Toxicity, Mobility, or Volume

No treatment is included under this RAA, therefore, no reduction in the toxicity or volume of the contaminated soil will occur. This alternative will reduce the mobility of soil contaminants by design of the cap. This RAA does not satisfy the statutory preference for treatment, but does meet the criteria for consideration of at least one containment alternative.

Short-Term Effectiveness

There will be a temporary increase in the risks to the community/base personnel during the excavation of the soils and the installation of the cap. Workers protection against dermal contact and inhalation of volatiles and particulates will be required during the excavation and cap installation activities. Once the cap is in place, minimal additional risks are anticipated to the community or to workers.

No additional environmental impacts are expected with respect to implementing this alternative.

The time to complete this remedial action is estimated to be 6 to 12 months for the excavation activities and the construction of the cap.

Implementability

With respect to technical feasibility, this alternative should be easily implemented since common earth-construction activities are required. This RAA will require extensive soil and material handling activities, especially at AOC No. 1 due to the location and dense-like physical characteristics of this area. The groundwater monitoring included under this RAA will provide notice of failure before significant migration and exposure occurs.

In terms of administrative feasibility, this alternative should require minimal coordination with other agencies following the ROD. No problems with the availability of required materials and/or equipment are anticipated.

Cost

The estimated capital cost associated with this RAA is approximately \$2.8 million. O&M costs of approximately \$39,000 annually are projected for the maintenance and inspections of the cap and for the sampling included in the long-term groundwater monitoring plan. Assuming an operating period of 30 years and an annual percentage rate of 5 percent, the NPW of this alternative is \$3.4 million.

USEPA/State Acceptance

Since the soil COCs are not removed or treated, it is expected that the EPA and State will not be in favor of this RAA.

Community Acceptance

It is unlikely that the community will be in favor of a "capping" alternative.

5.1.2.3 Soil RAA No. 3: On-Site Treatment

Description

In general, Soil RAA No. 3 includes the excavation and treatment of soil from all of the Soil AOCs via on-site treatment. The technologies/process options included with this RAA include soil excavation, grading, revegetation, fencing, and on-site treatment. The on-site treatment options may include one or more combinations of the following technologies: land treatment, in situ volatilization, chemical dechlorination, and incineration. The cost evaluation presented in this section will evaluate a few of the possible treatment combinations.

Assessment

Overall Protection of Human Health and the Environment

This alternative will provide overall protection to human health and to the environment since the contaminated soils from the various areas of concern will be excavated, treated, and disposed of properly. Therefore, the potential risks associated with exposure to the contaminated soils is eliminated.

Compliance With ARARs

All chemical-specific, action-specific, and location-specific ARARs will be met by this alternative.

Long-Term Effectiveness and Permanence

Following the completion of the RAA, there should be no significant risks (with respect to soil contamination) remaining at the operable unit since the contaminated soils will be removed from the AOCs and treated.

The possible combination of treatment technologies to be used under this RAA (i.e., land treatment, in situ volatilization, chemical dechlorination, and incineration) results in this RAA being adequate for treating the soil COCs. The reliability of any of the four treatment options is high, but bench or pilot scale treatability studies are required to determine final treatment levels. This alternative may be an effective and permanent option. A 5-year review will not be necessary with this RAA unless the treatment process takes longer than 5 years.

Reduction of Toxicity, Mobility, or Volume

Significant reduction in the toxicity, mobility, and volume of toxic compounds will occur with the implementation of this RAA. All of the four treatment options are irreversible methods. The goal of this RAA is that no residuals with concentrations exceeding the remediation goal will remain within the soil at the completion of the remedial action. Pilot and/or bench-scale testing will be required to ensure that the remediation goals are feasible. This RAA satisfies the statutory preference for treatment.

Short-Term Effectiveness

There will be a temporary increase in the risks to the community during the excavation of the soils and the operation of the treatment systems. Workers protection against dermal contact and inhalation will be required during the excavation and treatment operation activities.

With respect to environmental impacts, the treatment options such as land treatment, in situ volatilization, and incineration may impact air quality and odors, although they will be designed to meet emission standards.

Once implemented, this alternative will immediately reduce the levels of the COCs in the soils. The time to obtain the remedial objectives is estimated to be several months to five years (i.e., as soon as all of the excavated soils are excavated and treated on site). In situ volatilization and land treatment will require a longer time period than for incineration.

Implementability

All four of the treatment options will require operation. Long-term monitoring should not be required longer than five years for this RAA.

If incineration is selected, the technical intent of an incineration permit must be demonstrated. In addition, this RAA will require coordination with other agencies for meeting the intent of an air permit. The availability of a mobile incinerator may present a problem.

Land treatment, in situ volatilization, and dechlorination equipment and material should be readily available. All of the treatment options will require trained operators.

Cost

Cost estimates for a few combinations of the four treatment options applicable under this RAA have been calculated. These combinations include:

- Option A - On-site incineration of soils from all of the AOCs
- Option B - Land treatment of Soil AOCs 1, 2, and 5; incineration of Soil AOCs 3, 4, and 6
- Option C - In situ volatilization of Soil AOC1; incineration of Soil AOCs 2, 3, 4, 5, and 6
- Option D - In situ volatilization of Soil AOC1; land treatment of Soil AOCs 2 and 5; chemical dechlorination of Soil AOCs 3, 4, and 6

It is important to note that there are many more possible combinations for treatment. This cost evaluation was completed for Options A through D for purposes of comparing realistic remediation approaches. As a result, the estimated capital costs, operation and maintenance costs, and NPW values for these options are listed below. The details of the cost evaluation are presented in Appendix C.

	Treatment Options			
	A	B	C	D
Capital Costs	6.6 million	\$2.2 million	\$1.5 million	\$1.7 million
O&M Costs	\$0	\$330,000	\$50,000	\$50,000-\$80,000
NPW	\$6.6 million	\$3.1 million	\$1.7 million	\$2.0 million

USEPA/State Acceptance

Since this RAA includes the complete treatment of all the soil COCs, the USEPA and the State are expected to be in favor of this RAA.

Community Acceptance

It is expected that the community would be in favor of this RAA, with exception of the on-site incineration option.

5.1.2.4 Soil RAA No. 4: Capping and Partial On-Site Treatment
(All Areas of Concern)

Description

In general, Soil RAA No. 4 is a combination of Soil RAA Nos. 2 and 3. This RAA includes the excavation and consolidation of the PCB-contaminated soils and placement under a soil cover placed within Open Storage Lot 203 (i.e., partial capping); and the excavation and treatment of the soil from the remaining Soil AOCs (i.e., partial on-site treatment). The technologies/process options included with this RAA include monitoring, deed restrictions, fencing, capping, grading, revegetation, soil excavation, and on-site treatment. The principal

objectives of this RAA are to consolidate the PCB-contaminated soils into one area and to treat the other contaminated soils on site.

Assessment

Overall Protection of Human Health and the Environment

Soil RAA No. 4 provides protection to human health and to the environment in the form of reducing the potential for direct contact with the PCB-contaminated soil and since the other contaminated soils will be excavated and treated.

Compliance With ARARs

Under this alternative, contaminated soil exceeding the PCB remediation goal will remain at the operable unit, but will be contained to mitigate exposure and migration through the environment. Therefore, the contaminant-specific ARAR for PCBs will not be met. The other contaminant-specific ARARs will be met since the other contaminated soils will be excavated and treated.

The covered area will be located above the 100-year flood plain, therefore, the location-specific ARAR will be met.

Long-Term Effectiveness and Permanence

As long as the soil cover is maintained, potential risks due to exposure to the PCB-contaminated soils is reduced. But because the source of the PCB contamination is only contained, the inherent hazards related to this contamination still exist under this RAA. Following the completion of the RAA, there should be no potential risks (with respect to the non-PCB soil contamination) remaining at the operable unit since these other soils will be removed and treated.

With respect to adequacy and reliability, the cover can be both adequate and reliable if properly maintained. The possible combination of treatment technologies to be used under this RAA (i.e., land treatment, in situ volatilization, chemical dechlorination, and incineration) results in this RAA being adequate for treating the soil COCs other than PCBs.

The reliability of any of the four treatment options is high. This portion of the RAA is effective and permanent.

Since the PCB-contaminated soils will remain on site, Soil RAA No. 4 will require EPA's 5-year review to ensure adequate protection of human health and the environment is maintained.

Reduction of Toxicity, Mobility, or Volume

No treatment of the PCB-contaminated soils is included under this RAA, therefore, no reduction in the toxicity, mobility, or volume of the PCB contamination will occur. This portion of the RAA does not satisfy the statutory preference for treatment.

Significant reduction in the toxicity, mobility, and volume of toxic compounds within Soil AOCs 1, 2, and 5 will occur with the implementation of this RAA. All of the four treatment options are irreversible methods. No residuals with concentrations exceeding the remediation goal will remain within the Soil AOCs 1, 2, and 5. This portion of the RAA satisfies the statutory preference for treatment.

Short-Term Effectiveness

There will be a temporary increase in the risks to the community/base personnel during the excavation of the soils, the installation of the cover, and the operation of the treatment options. Workers protection against dermal contact and inhalation will be required during the excavation, cover installation, and activities.

With respect to environmental impacts, the treatment options such as land treatment, in situ volatilization, and incineration may impact air quality. Emission controls will likely be required in order to meet air quality standards.

Once implemented, this alternative will immediately reduce the levels of the COCs in the AOC soils. The time to obtain the remedial objectives is estimated to be several months to a year following the completion of the design and initial construction activities (i.e., as soon as all of the excavated soils are excavated, the cover is constructed and the remaining soils are treated on site).

Implementability

This RAA will require extensive soil and material handling activities. If the volume of contaminated soil exceeds the FS estimate, the treatment systems or the cover can be easily expanded. The groundwater monitoring included under this RAA will provide notice of failure of the cap before significant exposure occurs.

If incineration is selected, the technical intent of an incineration permit must be demonstrated. In addition, this RAA will require coordination with other agencies for meeting the intent of an air permit.

The availability of a mobile incinerator, if incineration is the technology selected, may present a problem. Land treatment, in situ volatilization, and dechlorination equipment and material should be readily available. All of the treatment options will require trained operators.

Cost

The estimated capital cost associated with this RAA is approximately \$926,000. O&M costs of approximately \$31,000 to \$81,000 annually are projected for the maintenance and inspections of the cap and for the sampling included in the long-term groundwater monitoring plan. No O&M costs have been included with this RAA relating to the on-site treatment activities since the duration of this portion of the remedial activity is anticipated to be less than one year. Assuming an operating period of 30 years and an annual percentage rate of 5 percent, the NPW of this alternative is \$1.6 million.

USEPA/State Acceptance

Since this RAA includes treatment of the majority of contaminated soils at the sites, it is expected that USEPA and the State to be in favor of this alternative.

Community Acceptance

It is expected that the community might be in favor of this alternative as long as on-site incineration is not used.

5.1.2.5 Soil RAA No. 5: Off-Site Treatment/Disposal

Description

In general, Soil RAA No. 5 includes the excavation and off-site treatment/disposal of the contaminated soils from all of the Soil AOCs. The approximate area of soils to be excavated and treated is the same as for Soil RAA No. 3. The technologies/process options included under this RAA include soil excavation, grading, revegetation, and off-site treatment and/or disposal at a permitted facility.

Assessment

Overall Protection of Human Health and the Environment

This alternative will provide overall protection to human health and to the environment since the contaminated AOC soils will be excavated and removed from the sites. Therefore, the potential risks associated with the contaminated soils is eliminated.

Compliance With ARARs

All chemical-specific, action-specific, and location-specific ARARs will be met by this alternative.

Long-Term Effectiveness and Permanence

Following the completion of the RAA, there should be a reduction in overall human health and environmental risks (with respect to soil contamination) remaining at the operable unit since the contaminated soils at the various AOCs will be removed.

Off-site treatment/disposal is both adequate and reliable. This alternative is an effective and permanent option. No 5-year review is necessary with this RAA.

Reduction of Toxicity, Mobility, or Volume

Significant reduction in the toxicity, mobility, and volume of toxic compounds will occur with the implementation of this RAA. Excavation is an irreversible option. No residuals with

concentrations exceeding the remediation goal will remain within the soil at the completion of the remedial action. This RAA satisfies the statutory preference for treatment.

Short-Term Effectiveness

There will be a temporary increase in the risks to the community during the excavation of the soils. Workers protection against dermal contact and inhalation will be required during the excavation activities. Minimal impacts to the environment are expected under this RAA.

Once implemented, this alternative will immediately reduce the levels of the COCs in the soils. The time to obtain the remedial objectives is estimated to be several months to a year following the design of this action (i.e., as soon as all of the excavated soils are excavated and removed from the sites).

Implementability

Long-term monitoring is not required for this RAA.

In terms of administrative feasibility, this alternative will require coordination with other agencies such as the Department of Transportation for the off-site transport of the soils. USEPA and State approval of the off-site facility would be required.

No problems with the availability of the excavation equipment are anticipated. The availability and capacity of a permitted facility capable of treating PCB-contaminated and solvent-contaminated soils may present a problem in implementing this alternative in a timely manner.

Cost

The estimated capital cost associated with this RAA is approximately \$5.5 million for nonhazardous disposal and \$20.4 million for treatment. No O&M costs have been included with this alternative since the duration of the remedial activity is anticipated to be less than one year. No long-term monitoring will be required since the COCs will be removed from the sites. Since there are no O&M costs for this alternative, the NPW is the same as the capital costs: \$5.5 million to \$20.4 million.

USEPA/State Acceptance

It is expected that the USEPA and the State will be in favor of this alternative since the soils are removed from the sites.

Community Acceptance

It is expected that the community will be in favor of this alternative since the contaminated soils are to be removed from the sites.

5.1.2.6 Soil RAA No. 6: Capping and On-Site Treatment (Limited Areas of Concern)

Description

In general, Soil RAA No. 6 is similar to Soil RAA No. 4. This RAA includes the excavation and consolidation of the contaminated soils from Soil AOCs 4 and 5 and placement under a soil cover placed within Open Storage Lot 203 (i.e., partial capping); and the in situ treatment of the soil from Soil AOC1 (i.e., partial on-site treatment). The technologies/process options included with this RAA include monitoring, deed restrictions, fencing, capping, grading, revegetation, soil excavation, and on-site treatment.

Assessment

Overall Protection of Human Health and the Environment

Soil RAA No. 6 provides protection to human health and to the environment in the form of reducing the potential for direct contact with the contaminated soils from AOCs 4 and 5 (PCBs and pesticides, respectively) and since the contaminated soils from AOC1 (VOCs) will be excavated and treated in situ.

Compliance With ARARs

Under this alternative, contaminated soil exceeding the PCB and pesticide remediation goals will remain at the operable unit, but will be contained to mitigate exposure and migration through the environment. Therefore, the contaminant-specific ARAR for PCBs and pesticides

will not be met. The other contaminant-specific ARARs will be met since the other contaminated soils will be treated.

The capped area will be located above the 100-year flood plain, therefore, the location-specific ARAR will be met.

Long-Term Effectiveness and Permanence

As long as the cover is maintained, potential risks due to exposure to the PCB-contaminated and pesticide-contaminated soils is reduced. But because the source of the contamination from AOCs 4 and 5 is only contained, the inherent hazards related to this contamination still exist under this RAA. Following the completion of the RAA, there should be no potential risks (with respect to the VOC contamination) remaining at the operable unit since these other soils will be removed and treated.

With respect to adequacy and reliability, the cap can be both adequate and reliable if properly maintained. In situ volatilization is adequate for treating the soil at AOC1. The reliability of this treatment option is high. This portion of the RAA is effective and permanent.

Since the PCB-contaminated and pesticide-contaminated soils will remain on site, Soil RAA No. 6 will require EPA's 5-year review to ensure that adequate protection of human health and the environment is maintained.

Reduction of Toxicity, Mobility, or Volume

No treatment of the contaminated soils from AOCs 2 through 6 is included under this RAA, therefore, no reduction in the toxicity, mobility, or volume of the PCB or pesticide contamination will occur. This portion of the RAA does not satisfy the statutory preference for treatment.

Significant reduction in the toxicity, mobility, and volume of toxic compounds within Soil AOC1 (which accounts for over 85 percent of the contaminated soil) will occur with the implementation of this RAA. No residuals with concentrations exceeding the remediation goal will remain within the Soil AOC1. This portion of the RAA satisfies the statutory preference for treatment.

Short-Term Effectiveness

There will be a temporary increase in the risks to the community/base personnel during the excavation of the soils, the installation of the cover, and the operation of the treatment option. Workers protection against dermal contact and inhalation will be required during the excavation, cap installation, and activities.

With respect to environmental impacts, in situ volatilization, may impact air quality. Emission controls will likely be required in order to meet air quality standard.

Once implemented, this alternative will immediately reduce the levels of the COCs in the soils from AOC1. The time to obtain the remedial objectives is estimated to be several months to 5 years following the completion of the design and initial construction activities (i.e., as soon as all of the excavated soils are excavated, the cover is constructed and the remaining soils are treated in situ.

Implementability

This RAA will require soil and material handling activities. If the volume of contaminated soil exceeds the FS estimate, the treatment system or the cover can be easily expanded. The groundwater monitoring included under this RAA will provide notice of failure of the cover before significant exposure occurs.

In situ volatilization equipment and material should be readily available. This treatment option will require trained operators.

Cost

The estimated capital cost associated with this RAA is approximately \$710,000. O&M costs of approximately \$31,000 to \$81,000 annually are projected for the maintenance and inspections of the cover and for the sampling included in the long-term groundwater monitoring plan and for on-site treatment activities. Assuming an operating period of 30 years and an annual percentage rate of 5 percent, the NPW of this alternative is \$1.4 million.

USEPA/State Acceptance

Since not all of the AOCs are remediated under this RAA, it is expected that the USEPA and the State will not be in favor of this alternative.

Community Acceptance

It is expected that the community will not be in favor of this alternative.

5.1.2.7 Soil RAA No. 7: On-Site Treatment and Off-Site Disposal

Description

In general, Soil RAA No. 7 includes the on-site treatment via in situ volatilization of the soils from AOC1 and the excavation and off-site disposal of the soils from the remaining five AOCs. The technologies/process options included under this RAA includes soil excavation, on-site treatment, off-site disposal, monitoring, deed restrictions, fencing, grading, and revegetation.

Assessment

Overall Protection of Human Health and the Environment

This alternative will provide overall protection to human health and to the environment since the contaminated AOC soils will be excavated and removed from the sites or treated on site. Therefore, the potential risks associated with the contaminated soils are eliminated.

Compliance With ARARs

All chemical-specific, action-specific, and location-specific ARARs will be met by this alternative.

Long-Term Effectiveness and Permanence

Following the completion of the RAA, there should be a reduction in overall human health and environmental risks (with respect to soil contamination) remaining at the operable unit since the contaminated soils at the various AOCs will be removed or treated.

Both in situ volatilization and off-site disposal are adequate options for soil remediation. Bench or pilot scale testing will be required to evaluate the effectiveness of the in situ treatment system. A 5-year review will not be necessary with this RAA unless the treatment process takes longer than 5 years.

Reduction of Toxicity, Mobility, or Volume

Significant reduction in toxicity, mobility, and volume of toxic compounds will occur with the implementation of this RAA. In situ volatilization is an irreversible option. No residuals with concentrations exceeding the remediation goal will remain within the soil at the completion of the remedial action. This RAA satisfies the statutory preference for treatment for the majority of the soils (over 85 percent).

Short-Term Effectiveness

There will be a temporary increase in the risks to the community during the excavation of the soils and during the treatment operations. Workers protection against dermal contact and inhalation will be required during these activities. With respect to environmental impacts, in situ volatilization may impact air quality, although the system will be designed to meet emission standards.

Once implemented, this alternative will immediately reduce the levels of the COCs in the soils. The time to obtain the remedial objectives is estimated to be several months to five years following the design of this action (i.e., as soon as all of the excavated soils are excavated or treated on site).

Implementability

The treatment option will require a trained operator. Long-term monitoring should not be required longer than five years.

In terms of administrative feasibility, this alternative will require coordination with other agencies such as the Department of Transportation for the off-site transport of the soils. USEPA and State approval of the off-site facility would be required.

No problems with the availability of the excavation or treatment equipment are anticipated. The availability and capacity of a permitted facility capable of disposing nonhazardous PCB-contaminated and pesticide-contaminated soils could present a problem in implementing this alternative in a timely manner.

Cost

The estimated capital cost associated with this RAA is approximately \$1.3 million. O&M costs of \$50,000 annually have been estimated for five years. Monitoring (soil sampling) costs have been included in the O&M costs. The estimated NPW for this RAA is \$1.5 million.

USEPA/State Acceptance

It is expected that the USEPA and the State will be in favor of this alternative since the soils are either removed from the sites or treated.

Community Acceptance

It is expected that the community will be in favor of this alternative since the contaminated soils are to be removed from the sites or treated.

5.2 Comparative Analysis

This FS has identified and evaluated a range of RAAs potentially applicable to the media of concern at OU No. 2. Tables 5-1 and 5-2 present a summary of this evaluation for groundwater and soil, respectively. A comparative analysis in which the alternatives are evaluated in relation to one another with respect to the nine evaluation criteria is presented below. The comparison is presented per media. The purpose of this analysis is to identify the relative advantages and disadvantages of each RAA.

TABLE 5-1

SUMMARY OF DETAILED ANALYSIS - GROUNDWATER RAAs
 FEASIBILITY STUDY CTO-0133
 MCB CAMP LEJEUNE, NORTH CAROLINA

Evaluation Criteria	RAA No. 1 No Action	RAA No. 2 Limited Action	RAA No. 3 Containment	RAA No. 4 Intensive Groundwater Extraction and Treatment	RAA No. 5 Groundwater Extraction and Treatment
OVERALL PROTECTIVENESS					
<ul style="list-style-type: none"> Human Health Protection 	No reduction in risk.	Institutional controls provide protection against risk from groundwater ingestion.	Migration of plume mitigated. Pump and treat provide protection against risk from groundwater ingestion.	Groundwater plumes treated. Pump and treat provide protection against risk from groundwater ingestion.	Groundwater plumes treated. Pump and treat provide protection against risk from groundwater ingestion.
<ul style="list-style-type: none"> Environmental Protection 	Allows continued contamination of the groundwater.	Allows continued contamination of the groundwater.	Migration of contaminated groundwater is reduced by pump and treat.	Migration of contaminated groundwater is reduced by pump and treat.	Migration of contaminated groundwater is reduced by pump and treat.
COMPLIANCE WITH ARARS					
<ul style="list-style-type: none"> Chemical-Specific ARARs 	Will exceed Federal and/or NC groundwater quality ARARs.	Will exceed Federal and/or NC groundwater quality ARARs.	May not meet Federal and NC groundwater quality ARARs.	Should meet Federal and NC groundwater quality ARARs in time.	Should meet Federal and NC groundwater quality ARARs in time.
<ul style="list-style-type: none"> Location-Specific ARARs 	Not applicable.	Not applicable.	Will meet location-specific ARARs.	Will meet location-specific ARARs.	Will meet location-specific ARARs.
<ul style="list-style-type: none"> Action-Specific ARARs 	Not applicable.	Not applicable.	Will meet action-specific ARARs.	Will meet action-specific ARARs.	Will meet action-specific ARARs.
LONG-TERM EFFECTIVENESS AND PERMANENCE					
<ul style="list-style-type: none"> Magnitude of Residual Risk 	As area of contamination increases, potential risks may increase.	Risk reduced to human health since the use of the groundwater aquifer is restricted.	Risk reduced by extracting contaminated groundwater.	Risk reduced by extracting contaminated groundwater.	Risk reduced by extracting contaminated groundwater.
<ul style="list-style-type: none"> Adequacy and Reliability of Controls 	Not applicable - no controls.	Reliability of institutional controls is uncertain.	Groundwater pump and treat is reliable.	Groundwater pump and treat is reliable.	Groundwater pump and treat is reliable.
<ul style="list-style-type: none"> Need for 5-year Review 	Review would be required to ensure adequate protection of human health and the environment is maintained.	Review would be required to ensure adequate protection of human health and the environment is maintained.	Review not needed once remediation goals are met.	Review not needed once remediation goals are met.	Review not needed once remediation goals are met.

TABLE 5-1 (Continued)

**SUMMARY OF DETAILED ANALYSIS - GROUNDWATER RAA's
FEASIBILITY STUDY CTO-0133
MCB CAMP LEJEUNE, NORTH CAROLINA**

Evaluation Criteria	RAA No. 1 No Action	RAA No. 2 Limited Action	RAA No. 3 Containment	RAA No. 4 Intensive Groundwater Extraction and Treatment	RAA No. 5 Groundwater Extraction and Treatment
REDUCTION OF TOXICITY, MOBILITY, OR VOLUME THROUGH TREATMENT					
• Treatment Process Used	None.	None.	Treatment train for metals removal, air stripping, and activated carbon.	Treatment train for metals removal, air stripping, and activated carbon.	Treatment train for metals removal, air stripping, and activated carbon.
• Amount Destroyed or Treated	None.	None.	Majority of contaminants in groundwater out edges of plumes.	Majority of contaminants in groundwater.	Majority of contaminant in groundwater plumes.
• Reduction of Toxicity, Mobility or Volume	None.	None.	Reduced volume and toxicity of contaminated groundwater.	Reduced volume and toxicity of contaminated groundwater.	Reduced volume and toxicity of contaminated groundwater.
• Residuals Remaining After Treatment	Not applicable - no treatment.	Not applicable - no treatment.	Minimal residuals after goals are met.	Minimal residuals after goals are met.	Minimal residuals after goals are met.
• Statutory Preference for Treatment	Not satisfied.	Not satisfied.	Satisfied.	Satisfied.	Satisfied.
SHORT-TERM EFFECTIVENESS					
• Community Protection	Risks to community not increased by remedy implementation.	Risks to community not increased by remedy implementation.	Potential risks during extraction and treatment.	Potential risks during extraction and treatment.	Potential risks during extraction and treatment.
• Worker Protection	No significant risk to workers.	No significant risk to workers.	Protection required during treatment.	Protection required during treatment.	Protection required during treatment.
• Environmental Impacts	Continued impacts from existing conditions.	Still would be continued migration of contamination.	Aquifer drawdown during extraction.	Aquifer drawdown during extraction.	Aquifer drawdown during extraction.
• Time Until Action is Complete	Not applicable.	Risks from potential groundwater ingestion reduced within 3 to 6 months due to institutional controls.	Estimated 30 years.	Estimated 30 years.	Estimated 30 years.
IMPLEMENTABILITY					
• Ability to Construct and Operate	No construction or operation activities.	No construction or operation activities.	Groundwater extraction and treatment systems requires installation.	Groundwater extraction and treatment systems requires installation.	Groundwater extraction and treatment systems requires installation.
• Ability to Monitor Effectiveness	No monitoring. Failure to detect contamination will result in potential ingestion of contaminated groundwater.	Proposed monitoring will give notice of failure before significant exposure occurs.	Adequate system monitoring.	Adequate system monitoring.	Adequate system monitoring.
• Availability of Services and Capacities; Equipment	None required.	None required.	Needs groundwater treatment equipment.	Needs groundwater treatment equipment.	Needs groundwater treatment equipment.
COSTS NPW	\$0	\$600,000	\$7.0 million	\$4.9 million	\$8.9 million

TABLE 5-2

**SUMMARY OF DETAILED ANALYSIS - SOIL RAAs
FEASIBILITY STUDY CTO-0133
MCB CAMP LEJEUNE, NORTH CAROLINA**

Evaluation Criteria	RAA No. 1 No Action	RAA No. 2 Capping	RAA No. 3 On-Site Treatment	RAA No. 4 Capping and On-Site Treatment (All Areas of Concern)	RAA No. 5 Off-Site Treatment	RAA No. 6 Capping and On-Site Treatment (Limited Areas of Concern)	RAA No. 7 On-Site Treatment and Off-Site Disposal
OVERALL PROTECTIVENESS							
• Human Health Protection	No reduction in risk.	Would reduce potential for direct contact with contaminated soil.	Excavation removes source of contamination.	Reduces potential for direct contact with PCB-contaminated soil and removes other contaminated soils.	Excavation removes source of contamination.	Reduces potential for direct contact with PCB-contaminated soil and removes other contaminated soils - based on existing land use scenario.	Excavation and/or treatment removes source of contamination.
• Environmental Protection	Allows contaminated soils to remain on site.	Allows contaminated soils to remain on site.	No additional environmental impacts.	No additional environmental impacts.	Contaminated soils exceeding remediation goal removed and treated.	No additional environmental impacts.	No additional environmental impacts.
COMPLIANCE WITH ARARs							
• Chemical-Specific ARARs	Will exceed ARARs.	Will exceed ARARs.	Will meet contaminant-specific ARARs.	PCB ARAR not met; other contaminant-specific ARARs met.	Will meet ARARs.	PCB ARAR not met; other contaminant-specific ARARs met (with respect to existing land use scenario).	Will meet ARARs.
• Location-Specific ARARs	Not applicable.	Will meet location-specific ARARs.	Will meet location-specific ARARs.	Will meet location-specific ARARs.	Will meet location-specific ARARs.	Will meet location-specific ARARs.	Will meet location-specific ARARs.
• Action-Specific ARARs	Not applicable.	Will meet action-specific ARARs.	Will meet action-specific ARARs.	Will meet action-specific ARARs.	Will meet action-specific ARARs.	Will meet action-specific ARARs.	Will meet action-specific ARARs.
LONG-TERM EFFECTIVENESS AND PERMANENCE							
• Magnitude of Residual Risk	Source has not been removed. Potential risks not reduced.	Contaminated soils are not removed from the site, but potential risk due to exposure to COCs are reduced as long as the cap is maintained.	Potential risk due to exposure to soil COCs removed.	Potential risks reduced as long as the cover is maintained.	Potential risk due to exposure to soil COCs removed.	Potential risks with respect to existing land use scenario reduced as long as the cap is maintained.	Potential risk due to exposure to soil COCs removed.
• Adequacy and Reliability of Controls	Not applicable - no controls.	Multilayered cap controls contaminated soil - can be a reliable option if maintained properly.	All treatment options are reliable.	Soil cover can be reliable and adequate. Treatment option reliable and adequate.	Off-site treatment is very reliable because contaminated soils are removed.	Soil cover can be reliable and adequate. Treatment option reliable and adequate.	Treatment option and off-site disposal are reliable.
• Need for 5-year Review	Review would be required to ensure adequate protection of human health and the environment is maintained.	Review would be required to ensure adequate protection of human health and the environment is maintained.	Review may not be needed since contaminated soil treated (unless treatment process lasts longer than 5 years).	Review would be required to ensure adequate protection of human health and the environment is maintained.	Review not needed since contaminated soil removed.	Review would be required to ensure adequate protection of human health and the environment is maintained.	Review may not be needed since contaminated soil treated (unless treatment process lasts longer than 5 years).

TABLE 5-2 (Continued)

SUMMARY OF DETAILED ANALYSIS - SOIL RAAs
 FEASIBILITY STUDY CTO-0133
 MCB CAMP LEJEUNE, NORTH CAROLINA

Evaluation Criteria	RAA No. 1 No Action	RAA No. 2 Capping	RAA No. 3 On-Site Treatment	RAA No. 4 Capping and On-Site Treatment (All Areas of Concern)	RAA No. 5 Off-Site Treatment	RAA No. 6 Capping and On-Site Treatment (Limited Areas of Concern)	RAA No. 7 On-Site Treatment and Off-Site Disposal
REDUCTION OF TOXICITY, MOBILITY, OR VOLUME THROUGH TREATMENT							
• Treatment Process Used	None.	None.	Combination of land treatment, in situ volatilization, chemical dechlorination, and/or incineration.	In situ volatilization, land treatment, or incineration.	Off-site treatment.	In situ volatilization, land treatment, or incineration.	In situ volatilization, off-site disposal.
• Amount Destroyed or Treated	None.	None.	Majority of soil COCs.	Majority of soil COCs with the exception of PCBs.	Majority of soil COCs.	Majority of soil COCs with the exception of PCBs.	Majority of soil COCs.
• Reduction of Toxicity, Mobility or Volume	None.	None (not through treatment).	Reduction in toxicity, mobility and volume of contaminated soil.	Reduction in toxicity, mobility and volume of non-PCB contaminated soils.	Reduction in toxicity, mobility and volume of contaminated soil.	Reduction in toxicity, mobility and volume of non-PCB contaminated soils.	Reduction in toxicity, mobility and volume of contaminated soil.
• Residuals Remaining After Treatment	Not applicable - no treatment.	Residuals are capped.	No residuals.	Only PCB-contaminated soils remain at sites.	No residuals.	PCB-contaminated soils and some other soil COCs.	No residuals.
• Statutory Preference for Treatment	Not satisfied.	Not satisfied.	Satisfied.	Satisfied for non-PCB contaminated soils, not for PCB-contaminated soils.	Satisfied.	Satisfied for non-PCB contaminated soils, not for PCB-contaminated soils (with respect to existing land use scenario).	Satisfied.
SHORT-TERM EFFECTIVENESS							
• Community Protection	Risks to community not increased by remedy implementation.	Temporary potential risks during soil excavation and cap installation activities.	Limited potential risks during soil excavation and treatment activities.	Temporary potential risks during soil excavation and cap installation activities and treatment activities.	Limited potential risks during soil excavation activities.	Temporary potential risks during soil excavation and cap installation activities and treatment activities.	Limited potential risks during soil excavation and treatment activities.
• Worker Protection	No significant risks to workers.	Temporary potential risks during soil excavation and cap installation activities.	Potential risks during soil excavation and treatment activities.	Temporary potential risks during soil excavation and cap installation activities and treatment activities.	Potential risks during excavation and transportation activities.	Temporary potential risks during soil excavation and cap installation activities and treatment activities.	Potential risks during soil excavation and treatment activities.
• Environmental Impacts	Continued impacts from existing conditions.	No additional environmental impacts.	Air quality and odors - but treatment system will be designed to meet standards.	Air quality and odors - but treatment system will be designed to meet standards and treatment activities.	No additional environmental impacts.	Air quality and odors - but treatment system will be designed to meet standards.	Air quality and odors - but treatment system will be designed to meet standards.
• Time Until Action is Complete	Not applicable.	Six to twelve months.	Up to five years.	Up to five years.	Six to twelve months.	Up to five years.	Up to five years.

TABLE 5-2 (Continued)

SUMMARY OF DETAILED ANALYSIS - SOIL RAAs
 FEASIBILITY STUDY CTO-0133
 MCB CAMP LEJEUNE, NORTH CAROLINA

Evaluation Criteria	RAA No. 1 No Action	RAA No. 2 Capping	RAA No. 3 On-Site Treatment	RAA No. 4 Capping and On-Site Treatment (All Areas of Concern)	RAA No. 5 Off-Site Treatment	RAA No. 6 Capping and On-Site Treatment (Limited Areas of Concern)	RAA No. 7 On-Site Treatment and Off-Site Disposal
IMPLEMENTABILITY							
<ul style="list-style-type: none"> Ability to Construct and Operate 	No construction or operation activities.	Simple to construct and maintain. Requires materials handling procedures.	Requires soil excavation activities. Requires assembly of treatment systems.	Simple to construct and maintain. Requires materials handling procedures. Requires soil excavation activities. Requires assembly of treatment systems.	Requires soil excavation activities. No other on-site operations.	Simple to construct and maintain. Requires materials handling procedures. Requires soil excavation activities. Requires assembly of treatment systems.	Requires soil excavation activities. Requires assembly of treatment systems.
<ul style="list-style-type: none"> Ability to Monitor Effectiveness 	No monitoring included.	Cap maintenance and groundwater monitoring will adequately monitor effectiveness.	Adequate system monitoring.	Adequate system monitoring.	No monitoring other than confirmation soil sampling.	Adequate system monitoring.	Adequate system monitoring.
<ul style="list-style-type: none"> Availability of Services and Capacities; Equipment 	None required.	No special services or equipment required. Cap materials should be readily available.	May need on-site mobile incinerator.	Equipment and material should be readily available.	Needs off-site treatment services.	Equipment and material should be readily available.	Equipment and material should be readily available. Needs off-site disposal services.
COSTS NPW	\$0	\$3.4 million	\$1.7 million to \$6.6 million	\$1.6 million	\$5.5 million to \$1.4 million	\$1.4 million	\$1.5 million

5.2.1 Groundwater RAA Comparison

5.2.1.1 Overall Protection of Human Health and the Environment

RAA No. 1 (No Action) does not provide protection to human health or the environment. Under the Limited Action RAA (No. 2), institutional controls will provide protection to human health, although the potential for further migration of the contaminated groundwater still exists. All of the remaining Groundwater RAAs provide some protection of human health and the environment. RAA No. 3 provides protection through preventing further migration of the contaminated groundwater plume. RAA No. 4 provides protection through removing and treating the most contaminated areas of groundwater contamination. RAA No. 5 provides the quickest method of protection since both migration is prevented and also the most contaminated areas are treated. It should be noted that RAAs Nos. 4 and 5 may result in complete restoration of the plume over time; however, remediation will continue for many years due to the magnitude and complexity of the groundwater problem. Therefore, it is doubtful that groundwater under Site 82 can be used in the near future as a potable supply without treatment (at the tap or a treatment facility).

5.2.1.2 Compliance with ARARs

RAA Nos. 1 and 2 will potentially exceed Federal and State ARARs. RAA Nos. 3, 4, and 5 will potentially meet all of their respective ARARs for the treated effluent. RAA No. 3 will not meet ARARs associated with a Class I aquifer. In time, RAA Nos. 4 and 5 will meet the remediation goals for a Class I aquifer.

5.2.1.3 Long-Term Effectiveness and Permanence

RAA No. 1 will not reduce potential risks due to exposure to contaminated groundwater. Risks will be reduced under RAA Nos. 2 through 5 through the implementation of the institutional controls and/or treatment. The reliability of enforcing aquifer-use restrictions is effective. RAAs 3 through 5 will provide additional long-term effectiveness and permanence because they use a form of treatment to reduce the potential hazards posed by the COCs present in the groundwater aquifer.

All of the RAAs will require a 5-year review.

5.2.1.4 Reduction of Toxicity, Mobility, or Volume Through Treatment

No form of treatment is included under RAA Nos. 1 and 2. RAA Nos. 1 and 2 do not satisfy the statutory preference for treatment, whereas the other RAAs do satisfy the preference. All of the "treatment" RAAs will provide reduction of toxicity, mobility and/or volume of contaminants in the groundwater aquifers.

5.2.1.5 Short-Term Effectiveness

Risks to community and workers are not increased with the implementation of RAA Nos. 1 and 2. Current impacts from existing conditions will continue under these two RAAs. Under RAA Nos. 3, 4, and 5, risks to the community and workers will be slightly increased due to a temporary increase in dust production and volatilization during the installation of the piping for the groundwater treatment system (during treatment operations for the workers). In addition, aquifer draw down will occur under RAA Nos. 3, 4, and 5. Discharge of the treated effluent to Wallace Creek under RAA No. 4 is not expected to increase risks to the aquatic habitat.

5.2.1.6 Implementability

No construction, operation, or administrative activities associated with RAA No. 1. There are no construction or operation activities associated with RAA No. 2 other than groundwater sampling which is easily performed. The remaining RAAs will require operation of a groundwater pump and treatment system which can be labor intensive. In addition, these RAAs would be required to meet the substantive requirements of an NPDES permit for discharging the treated effluent. Under RAA No. 4, the treated effluent can be discharged to Wallace Creek without significant impacts to flow or ecological risks. However, due to the volume of flow anticipated under RAA Nos. 3 and 5, the treated effluent would need to be discharged to the New River or via deep injection wells.

5.2.1.7 Cost

No costs are associated with RAA No. 1. The estimated NPW of the other Groundwater RAAs, in increasing order are: \$600,000 million for RAA No. 2, \$4.9 million for RAA No. 4, \$7.0 million for RAA No. 3, and \$8.9 million for RAA No. 5.

5.2.1.8 USEPA/State Acceptance

It is expected that the USEPA and the State will be in favor of the three treatment options but not the no action or limited action RAAs.

5.2.1.9 Community Acceptance

It is expected that the community will be in favor of the three treatment RAAs.

5.2.2 **Soil RAA Comparison**

5.2.2.1 Overall Protection of Human Health and the Environment

All of the Soil RAAs, with the exception of the No Action RAA (No.1), provide some type of protection to human health and the environment. RAA No. 2 (Capping) provides protection in the form of reducing the potential for direct contact with the contaminated soil and reducing the mobility of the contaminated soil. RAA Nos. 4 and 6 provide this protection (for the less mobile contaminants) in addition to treating the volatile/mobile COCs. RAA Nos. 3, 5, and 7 provide protection through removing and/or treating the contaminated soils.

5.2.2.2 Compliance with ARARs

RAA Nos. 1, 2, 4, and 6 will not meet all of the chemical-specific ARARs for the soil COCs remaining at the sites. RAA Nos. 3, 5, and 7 will meet all of the chemical-specific ARARs. Action-specific and location-specific ARARs should be met by all of the RAAs evaluated.

5.2.2.3 Long-Term Effectiveness and Permanence

RAA No. 1 is not an effective or permanent alternative. RAA Nos. 2, 4, and 6 will provide long-term effectiveness as long as the cap or cover is maintained. RAA Nos. 3, 5, and 7 provide the highest degree of long-term effectiveness and permanence since the contaminated soils are removed and/or treated.

RAA Nos. 1, 2, 4, and 6 will require a 5-year review. RAA Nos. 3 and 7 may require a 5-year review based on the duration of the treatment process.

5.2.2.4 Reduction of Toxicity, Mobility, or Volume Through Treatment

No form of treatment is included under RAA Nos. 1, and 2. Even though RAA 2 does not implement any form of treatment, the contaminated soils will be capped. Treatment including one or more of the following is included under the other RAAs: land treatment, in situ volatilization, chemical dechlorination, or incineration. Therefore, these "treatment" RAAs will reduce the toxicity, mobility, and/or volume of the COCs through treatment.

RAA Nos. 1 and 2 do not satisfy the statutory preference for treatment, whereas the other RAAs do satisfy the preference.

5.2.2.5 Short-Term Effectiveness

Risks to community and workers not increased with the implementation of RAA No. 1, and current impacts from existing conditions will continue to exist. Under RAA Nos. 2, 3, 4, 5, 6, and 7 risks to the community and workers will be temporarily increased during soil excavation activities. Risks will also be increased temporarily during the installation of the cap/cover (RAA Nos. 2, 4, and 6). With respect to RAA Nos. 3, 4, 5, 6, and 7, risks will be increased during the operation of the treatment options.

5.2.2.6 Implementability

With respect to implementability, RAA No. 1 would be the easiest alternative to implement since there are no activities associated with it. RAA No. 2 should be the next easiest to implement since the primary construction activities only require common earth construction equipment. RAA Nos. 5 and 7 may be more difficult to implement due to the unknown availability/capacity of an appropriate treatment and/or disposal facility. The implementability of RAA Nos. 3, 4, and 6 should be similar since they all include some form of on-site treatment.

5.2.2.7 Cost

No costs are associated with RAA No. 1. The estimated NPW of the other Soil RAAs, in increasing order are: \$1.4 million for RAA No. 6, \$1.5 million for RAA No. 7, \$1.6 million for RAA No. 4, \$3.4 million for RAA No. 2, \$5.5 million for RAA No. 5 (disposal), and \$20.4

million for RAA No. 5 (treatment). The NPW for the four treatment combination options costed for RAA No. 3 (on-site treatment) ranged from \$1.7 million to \$6.6 million.

5.2.2.8 USEPA/State Acceptance

It is anticipated that the USEPA and the State will be in favor of the RAAs that included treatment and/or removal of the Soil COCs.

5.2.2.9 Community Acceptance

It is anticipated that the community will be in favor of treatment and/or removal options.

6.0 REFERENCES

40 Code of Federal Regulations (CFR) 141. 1992. The Safe Drinking Water Act Maximum Contaminant Levels.

40 CFR 300.430. 1992. National Contingency Plan.

40 CFR 761. 1992. The PCB Spill Cleanup Policy.

Alexander, Robert E. 1989. Site Survey Report DRMO Lot 203, MCB Camp Lejeune, North Carolina. February 1, 1989.

Baker Environmental, Incorporated (Baker). 1993. Remedial Investigation Report for Operable Unit No. 2 (Sites 6 and 9), Marine Corps Base Camp Lejeune, North Carolina. Final. Prepared for the Department of the Navy Atlantic Division Naval Facilities Engineering Command, Norfolk, Virginia.

Baker. 1992. Final Remedial Investigation/Feasibility Study Work Plan for Sites 6, 9, 48, and 69. Camp Lejeune Marine Corps Base, Jacksonville, North Carolina. Prepared for Naval Facilities Engineering Command, Atlantic Division, Norfolk, Virginia. May 1992.

Environmental Science and Engineering, Inc. (ESE). 1992. Final Site Assessment Report for Sites 6, 48, and 69. Characterization Study to Determine Existence and Possible Migration of Specific Chemicals In Situ. Marine Corps Base Camp Lejeune, North Carolina. Prepared for the Naval Facilities Engineering Command, Atlantic Division. March 1992.

Federal Emergency Management Agency (FEMA). 1987. Flood Insurance Rate Map, Onslow County, North Carolina. Community-Panel Numbers 370340-0330C and 370340-0340C. July 2, 1987.

Fussell, John. 1991. Progress Reports for Bachmans Sparrow Survey. Submitted to the Department of Defense, United States Marine Corps Base Camp Lejeune, Environmental Management Department.

Geophex, Ltd. 1991. Wellhead Management Program Engineering Study 91-36. Submitted to Marine Corps Base Camp Lejeune, North Carolina. January 22, 1991.

Halliburton NUS Environmental Corporation (NUS). 1992. Draft Site Inspection Report, Site 82: Piney Green Road, Marine Corps Base, Camp Lejeune, Jacksonville, North Carolina. Prepared for Department of the Navy Atlantic Division Naval Facilities Engineering Command, Norfolk, Virginia.

LeBlond, Richard. 1991. Critical Species List - Camp Lejeune Endangered Species and Special-Interest Communities Survey. Principal Investigator.

Means Site Work & Landscape Cost Data, 1993. 12th Annual Edition. R.S. Means Company, Inc. Construction Consultants & Publishers, Kingston, MA.

Memorandum. January 17, 1989. Past Disposal Practices at DRMO Lot 203. Memorandum from Director, Natural Resources and Environmental Affairs Division to Assistant Chief of Staff, Facilities.

Memorandum. January 12, 1989. Unearthed 55-Gallon Drum of DDT and (4 each) 55-Gallon Drums of Unknown Substance at Camp Lejeune DRMO Lot 203. Memorandum from Director, Natural Resources and Environmental Affairs Division to Assistant Chief of Staff, Facilities

Memorandum. January 18, 1989. Unearthed 55-Gallon Drum of DDT and Unknown at DRMO Lot 203. Memorandum from Assistant Chief of Staff, Facilities to Director, Natural Resources and Environmental Affairs Division

Naval Facilities Engineering Command Unit Price Book. 1991. Cost Estimating System (CES). Norfolk, Virginia. Data base date 09/02/91.

North Carolina Administrative Code, Title 15A, Subchapter 2B, Section .0200. 1991. Classifications and Water Quality Standards Applicable to Surface Waters of North Carolina. North Carolina Department of Environment, Health, and Natural Resources.

North Carolina Administrative Code, Title 15A, Subchapter 2L, Section .0200. 1989. Classifications and Water Quality Standards Applicable to the Groundwaters of North Carolina. North Carolina Department of Environment, Health, and Natural Resources.

Rich, Gerald and Kenneth Cherry. 1987. Hazardous Waste Treatment Technologies. Third Printing. Pudvan Publishing Co., Northbrook, Illinois.

Sims, Ronald C. 1990. "Soil Remediation Techniques at Uncontrolled Hazardous Waste Sites," J. Air Waste Management. Volume 40, No.5, May 1990.

Testa, Stephen M. and Duane L. Winegardner. 1991. Restoration of Petroleum-Contaminated Aquifers. Lewis Publishers, Chelsea, Michigan.

USEPA. 1992(a). Dermal Exposure Assessment: Principles and Applications. Office of Research and Development. Washington, D.C. January 1992. EPA/600/8-91/011B.

USEPA. 1992(b). Environmental Protection Agency. Region IV Waste Management Screening Values for Hazardous Waste Sites.

USEPA. 1991(a). Role of Baseline Risk Assessment in Superfund Remedy Selection Decisions. U.S. Department of Commerce. OSWER Directive 9355.0-30.

USEPA. 1991(b). Human Health Evaluation Manual, Supplemental Guidance "Standard Default Exposure Factors". Office of Solid Waste and Emergency Response, Washington, D.C. March 25, 1991. OSWER Directive 9285.6-03.

USEPA. 1991(c). Guide for Conducting Treatability Studies Under CERCLA: Soil Vapor Extraction. Interim Guidance. Office of Emergency and Remedial Response, Washington, D.C. EPA/540/2-91/091A. September 1991.

USEPA. 1990(a). Guidance on Remedial Actions for Superfund Sites with PCB Contamination. Office of Emergency and Remedial Response, Washington, D.C. EPA/540/G-90/007. August 1990.

USEPA. 1990(b). Handbook of In Situ Treatment of Hazardous Waste Contaminated Soils. Risk Reduction Engineering Laboratory, Cincinnati, Ohio. USEPA/440/2-90/001.

USEPA. 1990(c). Technologies of Delivery or Recovery for the Remediation of Hazardous Waste Sites. University of Cincinnati, Cincinnati, Ohio. USEPA/600/2-89/066.

USEPA. 1990(d). Assessing UST Corrective Action Technologies: Early Screening of Cleanup Technologies for the Saturated Zone. Risk Reduction Engineering Laboratory, Cincinnati, Ohio. EPA.600/2-90/027. June 1990.

USEPA. 1989(a). Risk Assessment Guidance for Superfund Volume I. Human Health Evaluation Manual (Part A) Interim Final. Office of Solid Waste and Emergency Response. Washington, D.C. December 1989. EPA/540/1-89-002.

USEPA. 1989(b). Guide to Treatment Technologies for Hazardous Wastes at Superfund Sites. Office of Environmental Engineering and Technology Demonstration, Washington, D.C. USEPA/540/2-89/052.

USEPA. 1988(a). Guidance for Conducting Remedial Investigations and Feasibility Studies Under CERCLA. Interim Final. Office of Emergency and Remedial Response, Washington, D.C. USEPA/540/G-89004.

USEPA. 1988(b). CERCLA Compliance With Other Laws Manual: Draft Guidance. Office of Emergency and Remedial Response, Washington, D.C. USEPA/540/6-89-006.

USEPA. 1988(c). Technology Screening Guide for Treatment of CERCLA Soils and Sludges. Office of Solid Waste and Emergency Response, Washington, D.C. USEPA/540/2-88/004.

USEPA. 1988(d). Guidance on Remedial Actions for Contaminated Ground Water at Superfund Sites. Office of Emergency and Remedial Response, Washington, D.C. EPA/540/G-88/003. December, 1988.

USEPA. 1987(a). Underground Storage Tank Corrective Action Technologies. Hazardous Waste Engineering Research Laboratory. Cincinnati, Ohio. USEPA/625/6-87-015.

USEPA. 1987(b). Compendium of Costs of Remedial Technologies at Hazardous Waste Sites. USEPA/600/2-87/087.

USEPA. 1985. Hazardous Waste: Identification and Listing Leachate. Office of Solid Waste. Federal Register. July 29, 1986.

USEPA. 1984. Rapid Assessment of Exposure to Particulate Emissions from Surface Contamination Sites. Office of Health and Environmental Assessment. Washington D.C. September 1984.

USEPA. 1982. Handbook: Remedial Action at Waste Disposal Sites. Final Report. USEPA-625/6-82-006.

Vesilind, P. Aarne; J. Jeffrey Peirce. 1982. Environmental Engineering. Butterworth Publishers. Boston, MA.

Wagner, Kathleen; et al. 1986. Remedial Action Technology for Waste Disposal Sites. Second Edition. Noyes Data Corporation. Park Ridge, New Jersey.

Walters, J.R., and J.M. Goodson. 1991. Status of the Red-cockaded Woodpecker at Camp Lejeune, 1991. North Carolina State University. Submitted to the Department of Defense, United States Marine Corps Base Camp Lejeune, Environmental Management Department.

Roy F. Weston, Inc. (Weston). 1988. Remedial Technologies for Leaking Underground Storage Tanks. Prepared for Electric Power Research Institute. Lewis Publishers, Inc. Chelsea, Michigan.

Water and Air Research, Inc. 1983. Initial Assessment Study of Marine Corps Base Camp Lejeune, North Carolina. Prepared for Naval Energy and Environmental Support Activity.

Wentz, Charles. Hazardous Waste Management. McGraw-Hill Book Company. New York, New York. 1989.

APPENDIX A
ANALYTICAL DATA SUMMARY TABLES

**SEDIMENT DATA SUMMARY
 SITE 6 - BEAR HEAD CREEK
 FREQUENCY AND RANGE OF POSITIVE DETECTIONS
 COMPARED TO USEPA REGION IV SEDIMENT SCREENING VALUES
 REMEDIAL INVESTIGATION CTO-0133
 MCB CAMP LEJEUNE, NORTH CAROLINA**

Contaminant	Sediment Screening Value		Contaminant Frequency/Range		Comparison to Screening Values	
	ER-L ⁽¹⁾	ER-M ⁽²⁾	No. of Positive Detects/No. of Samples	Range of Positive Detections	No. of Positive Detects above ER-L	No. of Positive Detects above ER-M
4,4'-DDD	2.0	20	10/20	8.4 - 220	10	7
4,4'-DDE	2.0	15	11/20	5.7 - 68	11	10
4,4'-DDT	1.0	7.0	8/20	6.6 - 38	8	6
Arsenic	33	85	8/20	0.54 - 6.1	0	0
Benzo(a)pyrene	400	2,500	6/20	93 - 640	0	0
Cadmium	5.0	9.0	11/20	0.54 - 4.7	0	0
Chromium	80	145	18/20	2.3 - 16.4	0	0
Copper	70	390	13/20	1.2 - 28.1	0	0
Lead	35	110	20/20	2.5 - 70.4	5	0
PCB-1260 ⁽³⁾	50	400	10/20	51 - 370	10	0
Pyrene	350	2,200	2/20	60 - 76	0	0
Zinc	120	270	15/20	6.4 - 82.4	0	0

(1) ER-L - Effects Range Low

(2) ER-M - Effects Range Median

(3) Sediment Screening Value established for Total PCBs

(4) Organic concentrations reported in µg/kg, Inorganic concentrations reported in mg/kg

(5) Only contaminants with Screening Values are presented on Table

SEDIMENT DATA SUMMARY
SITE 6 - RAVINE
FREQUENCY AND RANGE OF POSITIVE DETECTIONS
COMPARED TO USEPA REGION IV SEDIMENT SCREENING VALUES
REMEDIAL INVESTIGATION CTO-0133
MCB CAMP LEJEUNE, NORTH CAROLINA

Contaminant	Sediment Screening Value		Contaminant Frequency/Range		Comparison to Screening Values	
	ER-L ⁽¹⁾	ER-M ⁽²⁾	No. of Positive Detects/No. of Samples	Range of Positive Detects	No. of Positive Detects above ER-L	No. of Positive Detects above ER-M
4,4'-DDD	2.0	20	6/11	4.1 - 45	6	4
4,4'-DDE	2.0	15	6/11	23 - 120	6	6
4,4'-DDT	1.0	7.0	8/11	14 - 210	8	8
Arsenic	33	85	4/11	0.61 - 4.3	0	0
Benzo(a)anthracene	230	1,600	3/11	43 - 1,100	2	0
Benzo(a)pyrene	400	2,500	3/11	70 - 1,000	2	0
Cadmium	5.0	9.0	9/11	0.53 - 5.9	0	0
Chromium	80	145	6/11	2.0 - 17.7	0	0
Chrysene	400	2,800	3/11	59 - 1,100	2	0
Copper	70	390	11/11	2.6 - 67.5	0	0
Dieldren	0.02	8.0	2/11	8.1 - 43	2	2
Fluoranthene	600	3,600	3/11	84 - 1,500	2	0
Lead	35	110	11/11	2.1 - 105	0	0
Mercury	0.15	1.3	9/11	0.03 - 0.75	4	0
PCB-1260 ⁽³⁾	50	400	6/11	29 - 360	5	0
Phenanthrene	225	1,380	3/11	50 - 1,600	2	2
Pyrene	350	2,200	4/11	96 - 2,100	2	0
Zinc	120	270	11/11	20.3 - 408	4	1

(1) ER-L - Effects Range Low

(2) ER-M - Effects Range Median

(3) Sediment Screening Value established for Total PCBs

(4) Organic concentrations reported in µg/kg, Inorganic concentrations reported in mg/kg

(5) Only contaminants with Screening Values are presented on Table

SOIL DATA SUMMARY - SITE 9
FREQUENCY AND RANGE OF ORGANIC POSITIVE DETECTIONS
REMEDIAL INVESTIGATION CTO-0133
MCB CAMP LEJEUNE, NORTH CAROLINA

Contaminant	Surface Soil (0-2 feet)		Subsurface Soil (Below one foot)	
	Range of Positive Detections	No. of Positive Detects/No. of Samples	Range of Positive Detections	No. of Positive Detects/No. of Samples
4,4'-DDD	ND	0/7	4.6-50	6/25
4,4'-DDE	13-650	4/7	17-39	5/25
4,4'-DDT	3.3-570	5/7	4.0-62	7/25
Alpha Chlordane	ND	0/7	2.9	1/25
1,1,1-Trichloroethane	1.0	1/7	ND	0/25
Tetrachloroethene	21	1/7	2-3	2/25
Benzo(b)fluoranthene	46	1/7	640	1/25
Acenaphthene	ND	0/7	280	1/25
Pyrene	59	1/7	1800	1/25
Chrysene	ND	0/7	400	1/25
Benzo(a)anthracene	ND	0/7	540	1/25
Fluoranthene	ND	0/7	1700	1/25
Anthracene	ND	0/7	140	1/25
Phenanthrene	ND	0/7	41-1200	2/25
Fluorene	ND	0/7	1700	1/25
Benzo(k)fluoranthene	ND	0/7	340	1/25
Dibenzofuran	ND	0/7	73	1/25
Benzo(a)pyrene	ND	0/7	370	1/25
Ideno(1,2,3-cd)pyrene	ND	0/7	190	1/25
Benzo(g,h,i)perylene	ND	0/7	200	1/25

- Notes: 1) Concentrations expressed in microgram per kilogram ($\mu\text{g}/\text{kg}$).
2) Organic contaminants were not detected in base-specific background samples.
3) ND - Not detected

SOIL DATA SUMMARY - SITE 9
FREQUENCY AND RANGE OF INORGANIC POSITIVE DETECTIONS
COMPARED TO BASE-SPECIFIC BACKGROUND CONCENTRATIONS
REMEDIAL INVESTIGATION CTO-0133
MCB CAMP LEJEUNE, NORTH CAROLINA

Contaminant	Surface Soil (0-2 feet)			Subsurface Soil (Below one foot)		
	Base-Specific Background Concentration	Range of Positive Detections	No. of Positive Detects/No. of Samples	Base-Specific Background Concentration	Range of Positive Detections	No. of Positive Detects/No. of Samples
Aluminum	<90.5 - 1,120	1,510 - 4,510	7/7	672 - 3,600	773 - 8,630	25/25
Antimony	<2.6 - 9.6	ND	0/7	2.5 - <9.7	ND	0/25
Arsenic	<0.56 - 0.91	ND	0/7	<0.61 - <0.65	0.62 - 2.3	5/25
Barium	3.5 - 16.5	4.9 - 8.9	6/7	<4.0 - 7.6	1.9 - 39.2	23/25
Beryllium	<0.06 - <0.2	ND	0/7	<0.05 - <0.02	0.06 - 0.06	2/25
Cadmium	<0.35 - <0.59	ND	0/7	<0.34 - <0.59	0.34 - 0.71	5/25
Calcium	108 - 10,700	179 - 47,100	6/7	<10.7 - 4.410	217 - 8,230	15/25
Chromium	<0.06 - <3.2	1.7 - 5.1	7/7	<3.2 - 6.0	1.8 - 8.8	24/25
Cobalt	<0.37 - <1.8	0.5 - 0.85	3/7	<0.35 - <1.8	0.41 - 0.66	4/25
Copper	<1.1 - 3.1	0.93 - 2.8	3/7	0.65 - 1.2	0.44 - 3.6	18/25
Iron	160 - 684	813 - 1,260	7/7	126 - 833	222 - 3,500	25/25
Lead	2.0 - 3.0	4.1 - 25.7	7/7	1.2 - 1.6	1.3 - 44.9	25/25
Magnesium	<20.2 - 200	64 - 811	4/7	<25.4 - 133	27.8 - 206	15/25
Manganese	<2.0 - 3.0	4.1 - 14.7	7/7	1.2 - 1.6	2.7 - 9.5	15/25
Mercury	<0.02 - <0.12	0.02 - 0.03	4/7	<0.02 - <0.08	0.02 - 0.04	14/25
Nickel	<1.5 - <3.3	ND	0/7	<1.4 - <3.4	1.6 - 2.6	5/25
Potassium	54.5 - 75	20.6 - 152	7/7	<81.6 - 187	18.6 - 246	29/25
Selenium	<0.93 - <1.0	ND	0/7	<1.0	ND	0/25
Silver	<0.37 - 62.0	ND	0/7	<0.35 - <2.0	ND	0/25
Sodium	<9.4 - <39.13	106	1/7	<14.5 - <26.5	ND	0/25
Thallium	<0.37 - <0.41	ND	0/7	<0.40 - <0.44	ND	0/25
Vanadium	<2.1 - 2.8	2.7 - 4.8	7/7	<1.5 - 4.7	1.4 - 9.6	23/26
Zinc	<1.1 - 23.1	6.8 - 18.1	4/7	<0.19 - 11.6	1.9 - 18.4	9/25

Notes: 1) Concentrations expressed in milligram per kilogram (mg/kg).
2) ND - Not detected

**SOIL DATA SUMMARY SITE 6 - LOT 201
 FREQUENCY AND RANGE OF ORGANIC POSITIVE DETECTIONS
 REMEDIAL INVESTIGATION CTO-0133
 MCB CAMP LEJEUNE, NORTH CAROLINA**

Contaminant	Surface Soil (0-2 feet)		Subsurface Soil (Below one foot)	
	Range of Positive Detections	No. of Positive Detects/No. of Samples	Range of Positive Detections	No. of Positive Detects/No. of Samples
1,1,1-Trichloroethane	2 - 42	3/19	4	1/19
1,4-Dichlorobenzene	37 - 38	4/17	36 - 51	3/18
4,4'-DDD	0.98 - 180,000	28/96	0.58 - 250,000	20/103
4,4'-DDE	4 - 17,000	43/96	1.4 - 5,200	10/103
4,4'-DDT	3 - 1,200,000	62/96	3.4 - 460,000	35/103
Alpha Chlordane	8.9	1/96	ND	0/103
Benzo(a)anthracene	47	1/17	ND	0/18
Benzo(a)pyrene	78	1/17	ND	0/18
Benzo(b)fluoranthene	61 - 160	3/17	ND	0/18
Benzo(k)fluoranthene	46	1/17	ND	0/18
Chrysene	39 - 88	3/17	ND	0/18
Dieldren	5.6 - 46	5/96	ND	0/103
Fluoranthene	43 - 94	3/17	ND	0/18
Gamma Chlordane	8.0	1/96	ND	0/103
PCB-1248	1,800	1/87	ND	0/89
PCB-1260	31 - 36	2/87	ND	0/89
Phenanthrene	36	1/17	ND	0/18
Pyrene	38 - 99	3/17	ND	0/18

- Notes: 1) Concentrations expressed in microgram per kilogram ($\mu\text{g}/\text{kg}$).
 2) Organic contaminants were not detected in base-specific background samples.
 3) ND - Not detected

**SOIL DATA SUMMARY SITE 6 - LOT 201
 FREQUENCY AND RANGE OF INORGANIC POSITIVE DETECTIONS
 COMPARED TO BASE-SPECIFIC BACKGROUND CONCENTRATIONS
 REMEDIAL INVESTIGATION CTO-0133
 MCB CAMP LEJEUNE, NORTH CAROLINA**

Contaminant	Surface Soil (0-2 feet)			Subsurface Soil (Below one foot)		
	Base-Specific Background Concentration	Range of Positive Detections	No. of Positive Detects/No. of Samples	Base-Specific Background Concentration	Range of Positive Detections	No. of Positive Detects/No. of Samples
Aluminum	<90.5 - 1,120	245-5,520	17/17	672 - 3,600	365-4,540	18/18
Antimony	<2.6 - 9.6	ND	0/17	2.5 - <9.7	ND	0/18
Arsenic	<0.56 - 0.91	0.91 - 9.7	11/17	<0.61 - <0.65	0.65 - 1.8	6/18
Barium	3.5 - 16.5	3.5 - 16.5	16/17	<4.0 - 7.6	1.3 - 8.2	10/18
Beryllium	<0.06 - <0.2	0.22	1/17	<0.05 - <0.02	ND	0/18
Cadmium	<0.35 - <0.59	0.51 - 1.5	9/17	<0.34 - <0.59	0.57 - 0.63	2/18
Calcium	108 - 10,700	402 - 286,000	17/17	<10.7 - 4.410	68 - 17,100	16/18
Chromium	<0.06 - <3.2	3.5 - 21.6	15/17	<3.2 - 6.0	0.84 - 6.7	13/18
Cobalt	<0.37 - <1.8	1.3 - 1.3	2/17	<0.35 - <1.8	ND	0/18
Copper	<1.1 - 3.1	0.75 - 27.8	17/17	0.65 - 1.2	0.44 - 1.7	7/18
Iron	160 - 684	238 - 4,260	17/17	126 - 833	137 - 3,610	18/18
Lead	2.0 - 3.0	1.0 - 78	17/17	1.2 - 1.6	0.87 - 4.2	18/18
Magnesium	<20.2 - 200	26 - 3,980	17/17	<25.4 - 133	13.7 - 259	18/18
Manganese	<2.0 - 3.0	4.2 - 204	17/17	1.2 - 1.6	0.53 - 12.6	18/18
Mercury	<0.02 - <0.12	ND	0/17	<0.02 - <0.08	ND	0/18
Nickel	<1.5 - <3.3	3.7 - 6.4	2/17	<1.4 - <3.4	ND	0/18
Potassium	54.5 - 75	30.6 - 567	16/17	<81.6 - 187	37 - 187	6/18
Selenium	<0.93 - <1.0	2.2	1/17	<1.0	ND	0/18
Silver	<0.37 - 62.0	ND	0/17	<0.35 - <2.0	ND	0/18
Sodium	<9.4 - <39.13	41.6 - 312	14/17	<14.5 - <26.5	10.6 - 31.7	6/18
Thallium	<0.37 - <0.41	ND	0/17	<0.40 - <0.44	ND	0/18
Vanadium	<2.1 - 2.8	1.6 - 18.3	17/17	<1.5 - 4.7	0.83 - 18.1	14/18
Zinc	<1.1 - 23.1	4.6 - 135	14/17	<0.19 - 11.6	1.8 - 11.6	5/18

Notes: 1) Concentrations expressed in milligram per kilogram (mg/kg).
 2) ND - Not Detected

**SOIL DATA SUMMARY SITE 6 - LOT 203
 FREQUENCY AND RANGE OF ORGANIC POSITIVE DETECTIONS
 REMEDIAL INVESTIGATION CTO-0133
 MCB CAMP LEJEUNE, NORTH CAROLINA**

Contaminant	Surface Soil (0-2 feet)		Subsurface Soil (Below one foot)	
	Range of Positive Detections	No. of Positive Detects/No. of Samples	Range of Positive Detections	No. of Positive Detects/No. of Samples
1,1,1-Trichloroethane	2 - 15	2/28	ND	0/35
1,2-Dichlorobenzene	160	1/28	200	1/35
1,4-Dichlorobenzene	34 - 160	3/28	34	1/35
2-Methylnaphthalene	3,100	1/28	70 - 2,400	4/35
4,4'-DDD	4.5 - 180	8/58	21 - 430	4/66
4,4'-DDE	3.8 - 2,100	27/58	4.9 - 470	5/66
4,4'-DDT	3.4 - 1,500	29/58	3.6 - 300	6/66
Acenaphthene	250 - 9,500	2/28	ND	0/35
Alpha Chlordane	2.3 - 72	3/58	ND	0/66
Anthracene	55 - 440	2/28	5,700	1/35
Benzo(a)anthracene	47 - 1,600	8/28	1,000	1/35
Benzo(a)pyrene	49 - 1,800	6/28	210	1/35
Benzo(b)fluoranthene	88 - 2,700	7/28	500	1/35
Benzo(g,h,i)perylene	41 - 1,000	3/28	ND	0/35
Benzo(k)fluoranthene	30 - 1,100	5/28	170	1/35
Carbazole	390 - 910	2/28	690 - 4,300	2/35
Chrysene	50 - 1,300	8/28	1,000	1/35
Dibenzofuran	140 - 890	2/28	63 - 3,500	3/35
Dieldren	3.6 - 270	4/58	4.4 - 220	4/66
Endosulfan II	4.4	1/58	ND	0/66
Endrin	21 - 130	3/58	ND	0/66
Fluoranthene	39 - 2,300	11/28	5,000	1/35
Fluorene	220 - 940	2/28	810 - 5,100	2/35
Gamma Chlordane	160	1/58	140	1/66
Indeno(1,2,3-cd)pyrene	42 - 1,000	5/28	ND	0/35
Naphthalene	1,400	1/28	78 - 1,500	3/35
PCB-1248	580	1/40	ND	0/49
PCB-1254	170 - 2,100	2/40	ND	0/49
PCB-1260	17 - 42,000	12/40	20 - 29,000	3/49
Pentachlorophenol	520	1/28	ND	0/35
Phenanthrene	60 - 2,000	6/28	120 - 8,700	2/35
Pyrene	42 - 2,800	11/28	3,600	1/35

- Notes: 1) Concentrations expressed in microgram per kilogram ($\mu\text{g}/\text{kg}$).
 2) Organic contaminants were not detected in base-specific background samples.
 3) ND - Not detected

SOIL DATA SUMMARY - SITE 6 - LOT 203
FREQUENCY AND RANGE OF INORGANIC POSITIVE DETECTIONS
COMPARED TO BASE-SPECIFIC BACKGROUND CONCENTRATIONS
REMEDIAL INVESTIGATION CTO-0133
MCB CAMP LEJEUNE, NORTH CAROLINA

Contaminant	Surface Soil (0-2 feet)			Subsurface Soil (Below one foot)		
	Base-Specific Background Concentration	Range of Positive Detections	No. of Positive Detects/No. of Samples	Base-Specific Background Concentration	Range of Positive Detections	No. of Positive Detects/No. of Samples
Aluminum	<90.5 - 1,120	495 - 4,170	27/27	672 - 3,600	292 - 5,360	35/35
Antimony	<2.6 - 9.6	13.5 - 51.2	4/27	2.5 - <9.7	2.8	1/35
Arsenic	<0.56 - 0.91	0.39 - 4.9	17/27	<0.61 - <0.65	0.78 - 23.9	16/35
Barium	3.5 - 16.5	2.7 - 47.8	23/27	<4.0 - 7.6	3.9 - 103	20/35
Beryllium	<0.06 - <0.2	0.21	1/27	<0.05 - <0.02	0.06 - 2.7	4/35
Cadmium	<0.35 - <0.59	0.48 - 9.3	10/27	<0.34 - <0.59	0.62 - 5.4	4/35
Calcium	108 - 10,700	44.4 - 92,100	26/27	<10.7 - 4.410	63.3 - 2,560	27/35
Chromium	<0.06 - <3.2	1.1 - 25.2	24/27	<3.2 - 6.0	1.2 - 42.9	31/35
Cobalt	<0.37 - <1.8	0.39 - 2.2	2/27	<0.35 - <1.8	0.53	1/35
Copper	<1.1 - 3.1	1.0 - 7.5	22/27	0.65 - 1.2	0.45 - 339	7/35
Iron	160 - 684	241 - 12,900	27/27	126 - 833	289 - 26,000	33/35
Lead	2.0 - 3.0	4.1 - 4,010	27/27	1.2 - 1.6	1.2 - 111	34/35
Magnesium	<20.2 - 200	12 - 1,680	27/27	<25.4 - 133	9.1 - 317	31/35
Manganese	<2.0 - 3.0	1.9 - 182	27/27	1.2 - 1.6	0.67 - 113	24/35
Mercury	<0.02 - <0.12	0.03 - 1.1	3/27	<0.02 - <0.08	0.13 - 3	3/35
Nickel	<1.5 - <3.3	1.8 - 13.2	4/27	<1.4 - <3.4	1.5 - 20.5	4/35
Potassium	54.5 - 75	27.7 - 195	11/27	<81.6 - 187	17 - 708	23/35
Selenium	<0.93 - <1.0	ND	0/27	<1.0	5.7	1/35
Silver	<0.37 - 62.0	ND	0/27	<0.35 - <2.0	ND	0/35
Sodium	<9.4 - <39.13	9.2 - 460	14/27	<14.5 - <26.5	13.5 - 883	5/35
Thallium	<0.37 - <0.41	ND	0/27	<0.40 - <0.44	0.54	1/35
Vanadium	<2.1 - 2.8	1.1 - 8.2	23/27	<1.5 - 4.7	0.41 - 15.3	32/35
Zinc	<1.1 - 23.1	1.1 - 604	24/27	<0.19 - 11.6	0.78 - 367	20/35

Notes: 1) Concentrations expressed in milligram per kilogram (mg/kg).
2) ND - Not Detected

**SOIL DATA SUMMARY SITE 6 (WOODED AREAS AND RAVINE) AND SITE 82
 FREQUENCY AND RANGE OF ORGANIC POSITIVE DETECTIONS
 REMEDIAL INVESTIGATION CTO-0133
 MCB CAMP LEJEUNE, NORTH CAROLINA**

Contaminant	Surface Soil (0-2 feet)		Subsurface Soil (Below one foot)	
	Range of Positive Detections	No. of Positive Detects/No. of Samples	Range of Positive Detections	No. of Positive Detects/No. of Samples
1,1,1-Trichloroethane	1 - 2	3/83	1.0	1/126
1,1,2,2-Tetrachloroethane	55,000	1/83	ND	0/126
1,2-Dichloroethene	1,500	1/83	5.0	1/126
1,4-Dichlorobenzene	39 - 74	11/83	49 - 300	3/126
2-Methylnaphthalene	42	1/83	37 - 11,000	2/126
4,4'-DDD	10 - 12,000	6/83	16	1/126
4,4'-DDE	2.2 - 4,200	34/83	3.5 - 67	9/126
4,4'-DDT	3.4 - 6,400	40/83	4 - 77	9/126
4-Methylphenol	120	1/83	ND	0/126
Acenaphthylene	84	1/83	ND	0/126
Acenaphthene	36 - 370	3/83	ND	0/126
Alpha Chlordane	3.6	1/83	ND	0/126
Anthracene	41 - 260	4/83	ND	0/126
Benzene	850	1/83	1.0	1/126
Benzo(a)anthracene	39 - 2,200	11/83	45 - 96	2/126
Benzo(a)pyrene	40 - 1,500	11/83	55 - 58	2/126
Benzo(b)fluoranthene	54 - 2,200	14/83	110	2/126
Benzo(g,h,i)perylene	40 - 1,300	7/83	ND	0/126
Benzo(k)fluoranthene	25 - 490	9/83	ND	0/126
Bromomethane	670 - 3,700	2/83	4 - 1,300	3/126
Chloromethane	620 - 9,800	2/83	490	1/126
Chrysene	44 - 1,600	12/83	68	1/126
Dibenz(a,h)anthracene	43 - 380	3/83	ND	0/126
Dibenzofuran	82 - 120	2/83	ND	0/126
Dieldren	4.6 - 87	15/83	3.4 - 280	3/126

- Notes: 1) Concentrations expressed in microgram per kilogram ($\mu\text{g}/\text{kg}$).
 2) Organic contaminants were not detected in site-specific background samples.
 3) ND - Not Detected

**SOIL DATA SUMMARY SITE 6 (WOODED AREAS AND RAVINE) AND SITE 82
 FREQUENCY AND RANGE OF ORGANIC POSITIVE DETECTIONS
 REMEDIAL INVESTIGATION CTO-0133
 MCB CAMP LEJEUNE, NORTH CAROLINA**

Contaminant	Surface Soil (0-2 feet)		Subsurface Soil (Below one foot)	
	Range of Positive Detections	No. of Positive Detects/No. of Samples	Range of Positive Detections	No. of Positive Detects/No. of Samples
Endrin	5.6 - 240	2/83	ND	0/126
Fluoranthene	40 - 2,000	15/83	61 - 85	3/126
Fluorene	130 - 200	2/83	ND	0/126
Ideno(1,2,3-cd)pyrene	45 - 1,300	5/83	ND	0/126
Naphthalene	71 - 140	2/83	9,600	1/126
PCB-1260	28 - 26,000	7/83	46 - 100	4/126
Phenanthrene	46 - 1,500	2/83	31 - 70	2/126
Phenol	37 - 160	4/83	ND	0/126
Pyrene	72 - 2,700	13/83	63 - 110	3/126
Tetrachloroethene	2,600 - 7,000	2/83	9 - 11,000	2/126
Toluene	120	1/83	1-34	4/126
Trichloroethene	4,600	1/83	1.0	1/126

- Notes: 1) Concentrations expressed in microgram per kilogram ($\mu\text{g}/\text{kg}$).
 2) Organic contaminants were not detected in site-specific background samples.
 3) ND - Not Detected

**SOIL DATA SUMMARY SITE 6 (WOODED AREAS AND RAVINE) AND SITE 82
 FREQUENCY AND RANGE OF INORGANIC POSITIVE DETECTIONS
 COMPARED TO BASE-SPECIFIC BACKGROUND CONCENTRATIONS
 REMEDIAL INVESTIGATION CTO-0133
 MCB CAMP LEJEUNE, NORTH CAROLINA**

Contaminant	Surface Soil (0-2 feet)			Subsurface Soil (Below one foot)		
	Base-Specific Background Concentration	Range of Positive Detections	No. of Positive Detects/No. of Samples	Base-Specific Background Concentration	Range of Positive Detections	No. of Positive Detects/No. of Samples
Aluminum	<90.5 - 1,120	177 - 19,200	81/82	672 - 3,600	135 - 15,500	126/126
Antimony	<2.6 - 9.6	3.5 - 13.2	2/82	2.5 - <9.7	2.4 - 4.4	4/126
Arsenic	<0.56 - 0.91	0.49 - 26.3	36/82	<0.61 - <0.65	0.56 - 25.4	37/126
Barium	3.5 - 16.5	1.1 - 1,410	27/82	<4.0 - 7.6	0.91 - 1,100	84/126
Beryllium	<0.06 - <0.2	0.06 - 2.2	13/82	<0.05 - <0.02	0.06 - 3.1	17/126
Cadmium	<0.35 - <0.59	0.4 - 51.9	30/82	<0.34 - <0.59	0.33 - 2.5	25/126
Calcium	108 - 10,700	59.6 - 174,000	70/82	<10.7 - 4.410	10.4 - 5,640	53/126
Chromium	<0.06 - <3.2	0.72 - 54.6	55/82	<3.2 - 6.0	0.73 - 31.6	107/126
Cobalt	<0.37 - <1.8	0.34 - 13.7	14/82	<0.35 - <1.8	0.41 - 6.8	11/126
Copper	<1.1 - 3.1	0.39 - 348	38/82	0.65 - 1.2	0.33 - 733	45/126
Iron	160 - 684	113 - 149,000	78/82	126 - 833	57.4 - 19,200	107/126
Lead	2.0 - 3.0	2 - 1,710	71/82	1.2 - 1.6	0.89 - 1,610	89/126
Magnesium	<20.2 - 200	12.3 - 2,580	72/82	<25.4 - 133	8.2 - 637	97/126
Manganese	<2.0 - 3.0	1.1 - 700	70/82	1.2 - 1.6	0.2 - 2,990	72/126
Mercury	<0.02 - <0.12	0.02 - 3.9	35/82	<0.02 - <0.08	0.02 - 2	26/126
Nickel	<1.5 - <3.3	1.7 - 79.4	15/82	<1.4 - <3.4	1.6 - 11.7	12/126
Potassium	54.5 - 75	15 - 2,560	71/82	<81.6 - 187	14.2 - 1,270	94/126
Selenium	<0.93 - <1.0	0.9 - 5.8	8/82	<1.0	1.4 - 10.5	2/126
Silver	<0.37 - 62.0	0.47 - 0.49	2/82	<0.35 - <2.0	0.39	1/126
Sodium	<9.4 - <39.13	9.6 - 809	18/82	<14.5 - <26.5	10.1 - 50.6	10/126
Thallium	<0.37 - <0.41	0.35 - 0.57	2/82	<0.40 - <0.44	0.41 - 0.76	2/126
Vanadium	<2.1 - 2.8	0.36 - 35.7	72/82	<1.5 - 4.7	0.41 - 35.6	108/126
Zinc	<1.1 - 23.1	1.6 - 16,600	39/82	<0.19 - 11.6	0.73 - 2,450	18/126

Notes: 1) Concentrations expressed in milligram per kilogram (mg/kg).

GROUNDWATER DATA SUMMARY
OPERABLE UNIT NO. 2
FREQUENCY AND RANGE OF POSITIVE DETECTIONS
COMPARED TO NORTH CAROLINA AND FEDERAL GROUNDWATER CRITERIA
REMEDIAL INVESTIGATION CTO-0133
MCB CAMP LEJEUNE, NORTH CAROLINA

Contaminant	Groundwater Criteria				Contaminant Frequency/Range		Comparison to Criteria			
	North Carolina NCWQS ⁽¹⁾	Federal MCLs ⁽²⁾	Federal Health Advisories ⁽³⁾		No. of Positive Detects/ No. of Samples	Range of Positive Detects	No. of Positive Detects above NCWQS	No. of Positive Detects above MCLs	No. of Positive Detects above Health Advisories	
			10 kg Child	70 kg Adult					10 kg Child	70 kg Adult
1,1,1-Trichloroethane	200	200	10,000	10,000	1/49	0.5	0	0	0	0
1,1,2,2-Tetrachloroethene	--	--	--	--	2/49	1.0 - 6.9	NA	NA	NA	NA
1,1,2-Trichloroethane	--	5.0	600	1,000	1/49	0.5	NA	0	0	0
1,1-Dichloroethene	7.0	7.0	2,000	4,000	1/49	0.6	0	0	0	0
1,2-Dichloroethane	0.38	5.0	700	2,600	1/49	0.6	1	0	0	0
Antimony	--	6.0	15	15	2/49	15.3 - 15.6	NA	2	2	2
Arsenic	50	50	--	--	20/49	3.0 - 67.8	1	1	NA	NA
Barium	1,000	2,000	--	--	42/49	20.4 - 1,060	2	0	NA	NA
Beryllium	--	4.0	30,000	20,000	9/49	0.55 - 7.5	NA	2	0	0
Bromodichloromethane	--	100	7,000	13,000	1/49	0.6	NA	0	0	0
Cadmium	5.0	5.0	40	20	0/49	ND	NA	NA	NA	NA
Chlorobenzene	300	--	--	--	1/49	110 - 110	0	NA	NA	NA
Chromium	50	100	1,000	800	33/49	5.2 - 214	12	11	0	0
Cobalt	--	--	--	--	10/49	2.3 - 10.9	NA	NA	NA	NA
Copper	1,000	1,300	--	--	13/49	14 - 175	0	0	NA	NA
Cyanide	154	200	200	800	0/49	ND	NA	NA	NA	NA
Ethylbenzene	29	700	30,000	3,000	1/49	48	1	0	0	0
Lead	50	15	--	--	29/49	1.0 - 200	8	15	NA	NA
Manganese	50	50 ⁽⁴⁾	--	--	44/49	21 - 362	13	13	NA	NA
Mercury	1.1	2.0	--	2.0	14/49	0.07 - 1.4	1	0	NA	0
Nickel	150	100	1,000	1,700	15/49	11.1 - 41.9	0	0	0	0
Phenol	--	--	6,000	20,000	8/49	1.0 - 22	NA	NA	0	0
T-1,2-Dichloroethene	70	100	20,000	6,000	4/49	16 - 5,800	3	3	0	0
Tetrachloroethene	0.7	5.0	2,000	5,000	6/49	0.9 - 630	6	2	0	0
Total Xylenes	400	10,000	40,000	100,000	2/49	0.9 - 1.4	0	0	0	0
Trichloroethene	2.8	5.0	--	--	10/49	0.5 - 58,000	4	4	NA	NA
Vanadium	--	--	--	--	33/49	2.6 - 330	NA	NA	NA	NA
Vinyl Chloride	0.015	2.0	3,000	50	1/49	1.6	1	0	0	0
Zinc	5,000	5,000 ⁽⁴⁾	6,000	12,000	20/49	13.9 - 1,620	0	0	0	0

- Notes: (1) NCWQS - North Carolina Water Quality Standards for Groundwater
(2) MCL - Maximum Contaminant Level
(3) Longer Term Health Advisories for 10 kg Child and 70 kg Adult
(4) SMCL - Secondary Maximum Contaminant Level
(5) All concentrations expressed in µg/L
(6) -- No ARAR published
(7) NA - Not applicable
(8) ND - Not detected

**SURFACE WATER DATA SUMMARY
 SITE 6 - WALLACE CREEK
 FREQUENCY AND RANGE OF DETECTIONS
 COMPARED TO NORTH CAROLINA AND FEDERAL SURFACE WATER CRITERIA
 REMEDIAL INVESTIGATION CTO-0133
 MCB CAMP LEJEUNE, NORTH CAROLINA**

Contaminant	Surface Water Criteria			Contaminant Frequency/Range		Comparison to Criteria		
	North Carolina NCWQS ⁽¹⁾	Federal AWQCs ⁽²⁾		No. of Positive Detects/No. of Samples	Range of Positive Detects	No. of Positive Detects Above NCWQS	No. of Positive Detects above AWQCs	
		Acute	Chronic				Acute	Chronic
Arsenic	50	--	--	1/28	3.7	0	NA	NA
Barium	--	--	--	6/28	16 - 22.6	NA	NA	NA
Cadmium	2.0	3.9	1.1	2/28	3.2 - 17.4	2	1	2
Chromium	50	16	11	1/28	4.9	0	0	0
Copper	7	18	12	6/28	3 - 209	4	4	4
Lead	25	83	3.2	9/28	1.2 - 10.4	0	0	0
Manganese	--	--	--	26/28	8.2 - 25	NA	NA	NA
Mercury	0.012	2.4	0.012	3/28	0.24 - 0.52	3	0	3
Nickel	88	1,400	160	4/28	102 - 1,380	4	0	3
T-1,2-Dichloroethene	--	--	--	13/28	2 - 85	NA	NA	NA
Tetrachloroethene	--	5,280	840	3/28	1 - 4	NA	0	0
Toluene	11	17,500	--	4/28	1 - 3	0	0	NA
Trichloroethene	--	45,000	21,900	12/28	3 - 98	NA	0	0
Vanadium	--	--	--	9/28	1.9 - 3.3	NA	NA	NA
Vinyl Chloride	--	--	--	1/28	6	NA	NA	NA
Zinc	50	120	110	10/28	7.3 - 111	2	0	1

- (1) NCWQS - North Carolina Water Quality Standards for the Protection of Aquatic Life
- (2) AWQC - Ambient Water Quality Standards for the Protection of Fresh Water
- (3) -- No ARAR published
- (4) All concentrations expressed in microgram per liter (µg/L)
- (5) NA - Not Applicable

**SURFACE WATER DATA SUMMARY
 SITE 6 - BEAR HEAD CREEK
 FREQUENCY AND RANGE OF DETECTIONS
 COMPARED TO NORTH CAROLINA AND FEDERAL SURFACE WATER CRITERIA
 REMEDIAL INVESTIGATION CTO-0133
 MCB CAMP LEJEUNE, NORTH CAROLINA**

Contaminant	Surface Water Criteria			Contaminant Frequency/Range		Comparison to Criteria		
	North Carolina NCWQS ⁽¹⁾	Federal AWQCs ⁽²⁾		No. of Positive Detects/No. of Samples	Range of Positive Detections	No. of Positive Detects Above NCWQS	No. of Positive Detects above AWQCs	
		Acute	Chronic				Acute	Chronic
Arsenic	50	--	--	0/14	ND	NA	NA	NA
Barium	--	--	--	14/14	13.4 - 36	NA	NA	NA
Cadmium	2.0	3.9	1.1	0/14	ND	NA	NA	NA
Chromium	50	16	11	3/14	4.4 - 8	0	0	0
Copper	7	18	12	3/14	4.0 - 55.8	1	1	1
Lead	25	83	3.2	10/14	1.5 - 8.2	0	0	2
Manganese	--	--	--	14/14	6.2 - 65	NA	NA	NA
Mercury	0.012	2.4	0.012	2/14	0.05 - 0.34	2	0	0
Nickel	88	1,400	160	2/14	8.0 - 244	1	0	1
Vanadium	--	--	--	3/14	2.0 - 3.0	NA	NA	NA
Zinc	50	120	110	3/14	6.2 - 30.7	0	0	0

- (1) NCWQS - North Carolina Water Quality Standards for the Protection of Aquatic Life
- (2) AWQC - Ambient Water Quality Standards for the Protection of Fresh Water
- (3) -- No ARAR published
- (4) All concentrations expressed in microgram per liter (µg/L)
- (5) NA - Not applicable
- (6) ND - Not detected

**SURFACE WATER DATA SUMMARY
SITE 6 - RAVINE
FREQUENCY AND RANGE OF DETECTIONS
COMPARED TO NORTH CAROLINA AND FEDERAL SURFACE WATER CRITERIA
REMEDIAL INVESTIGATION CTO-0133
MCB CAMP LEJEUNE, NORTH CAROLINA**

Contaminant	Surface Water Criteria			Contaminant Frequency/Range		Comparison to Criteria		
	North Carolina NCWQS ⁽¹⁾	Federal AWQCs ⁽²⁾		No. of Positive Detects/No. of Samples	Range of Positive Detections	No. of Positive Detects Above NCWQS	No. of Positive Detects above AWQCs	
		Acute	Chronic				Acute	Chronic
Arsenic	50	--	--	3/6	2.2 - 10.5	0	NA	NA
Barium	--	--	--	6/6	37.1 - 91	NA	NA	NA
Cadmium	2.0	3.9	1.1	2/6	3.7 - 4.3	2	1	2
Chromium	50	16	11	2/6	4.2 - 6.5	0	0	0
Copper	7	18	12	6/6	4.7 - 9.0	4	0	0
Lead	25	83	3.2	6/6	1.9 - 12.2	0	0	4
Manganese	--	--	--	6/6	38.6 - 597	NA	NA	NA
Mercury	0.012	2.4	0.012	0/6	ND	NA	NA	NA
Nickel	88	1,400	160	0/6	ND	NA	NA	NA
Vanadium	--	--	--	1/6	6.2	NA	NA	NA
Zinc	50	120	110	6/6	72.7 - 495	6	4	5

- (1) NCWQS - North Carolina Water Quality Standards for the Protection of Aquatic Life
- (2) AWQC - Ambient Water Quality Standards for the Protection of Fresh Water
- (3) -- No ARAR published
- (4) All concentrations expressed in microgram per liter (µg/L)
- (5) NA - Not applicable
- (6) ND - Not detected

**SEDIMENT DATA SUMMARY
 SITE 6 - WALLACE CREEK
 FREQUENCY AND RANGE OF POSITIVE DETECTIONS
 COMPARED TO USEPA REGION IV SEDIMENT SCREENING VALUES
 REMEDIAL INVESTIGATION CTO-0133
 MCB CAMP LEJEUNE, NORTH CAROLINA**

Contaminant	Sediment Screening Value		Contaminant Frequency/Range		Comparison to Screening Values	
	ER-L(1)	ER-M (2)	No. of Positive Detects/No. of Samples	Range of Positive Detections	No. of Positive Detects above ER-L	No. of Positive Detects above ER-M
4,4'-DDD	2.0	20	15/33	7.4 - 200	15	12
4,4'-DDT	1.0	7.0	3/33	200 - 2,000	3	3
4,4'-DDE	2.0	15	14/33	5.9 - 83	14	11
Arsenic	33	85	15/33	1.0 - 10.2	0	0
Benzo(a)anthracene	230	1,600	4/33	67 - 210	0	0
Benzo(a)pyrene	400	2,500	6/33	63 - 1,600	3	0
Chromium	80	145	27/33	1.2 - 28.5	0	0
Chrysene	400	2,800	3/33	74 - 230	0	0
Copper	70	390	25/33	0.43 - 53,200	2	1
Dieldren	0.02	8.0	1/33	4.8	1	0
Fluoranthene	600	3,600	11/33	94 - 760	1	0
Lead	35	110	33/33	1.5 - 314	6	2
Nickel	30	50	5/33	2.7 - 10.7	0	0
PCB-1260 (3)	50	400	14/33	31 - 2,100	12	6
Pyrene	350	2,200	12/33	95 - 810	2	0
Zinc	120	270	19/33	6.2 - 926	4	2

- (1) ER-L - Effects Range Low
- (2) ER-M - Effects Range Median
- (3) Sediment Screening Value established for Total PCBs
- (4) Organic concentrations reported in µg/kg, Inorganic concentrations reported in mg/kg
- (5) Only contaminants with Screening Values are presented on Table

APPENDIX B
ACTION LEVEL CALCULATIONS

The Organic Leachate Model (OLM) is a model used for predicting the concentration of organic compounds in leachate. This model can be used in conjunction with the Vertical and Horizontal Spread Model (VHS). The OLM is an empirical equation which was developed through application of modeling techniques.

$$C1 = 0.00211 * Cw^{0.678} * S^{0.373}$$

Soil Cleanup Goal

$$Cs = ((C1)/(0.00211)*(S^{0.373}))^{1.4749}$$

Where:

C1 = Constituent concentration in leachate (ppm)

Cw = Constituent concentration in waste (soil) (ppm)

S = Constituent Solubility (ppm)

Constituent	Constant	Constituent Solubility (ppm)	Maximum Concentration in Soil (ppm)	Soil Cleanup Goal (ppm)	Constituent Concentration in Leachate (ppm)	State or Federal Criteria (ppm)
Chloromethane	0.00211	6450	0.49	--	0.0343	NE
Bromomethane	0.00211	900	1.3	--	0.0319	NE
Benzene	0.00211	1780	0.85	0.0054	0.0308	0.001
1,2-Dichloroethene	0.00211	600	1.5	5.1842	0.0302	0.07
Trichloroethene	0.00211	1100	4.6	0.0322	0.0809	0.0028
1,1,2,2-Tetrachloroethane	0.00211	2900	55	--	0.6248	NE
1,1,1-Trichloroethene	0.00211	720	0.042	22.0586	0.0029	0.2
Tetrachloroethane	0.00211	200	3.7	0.0107	0.0370	0.0007
4,4'-DDD	0.00211	0.09	12	--	0.0046	NE
4,4'-DDE	0.00211	0.04	4.2	--	0.0017	NE
4,4'-DDT	0.00211	0.0055	6.4	--	0.0011	NE
Dieldren	0.00211	0.195	0.28	--	0.0005	NE
Gamma Chlordane	0.00211	0.056	0.16	4.5121	0.0002	0.002
Aroclor 1260	0.00211	0.0027	42	3.0962	0.0029	0.0005

-- Cannot be estimated

NE - No criteria established

References:

1. Federal Register Vol 51, July 29, 1989
2. USEPA AQUATIC FATE PROCESS DATA FOR ORGANIC PRIORITY POLLUTANTS

PARTICULATE INHALATION ACTION LEVEL
ADULT

$$C = TR \text{ or } THI * BW * ATc \text{ or } ATnc * DY / CSF \text{ or } 1/RfD * EF * ED * IR * 1/PEF$$

Where:	INPUTS
C = contaminant concentration in soil (ug/kg)	Calculated
TR = total lifetime risk for carcinogen (unitless)	1.0E-04
THI = total Hazard Index for noncarcinogen (unitless)	1
CSF = carcinogenic slope factor	Specific
RfD = reference dose for noncarcinogen	Specific
IR = inhalation rate (m3/hr)	0.83
EF = exposure frequency (days/yr)	350
ET = exposure time (hour/day)	16
ED = exposure duration (years)	30
BW = body weight (kg)	70
ATc = averaging time for carcinogen (yr)	70
ATnc = averaging time for noncarcinogen (yr)	30
DY = day per year (day/yr)	365
PEF = particulate emission factor (m3/kg)	Cowherd

Note: Inputs are scenario and site specific

Contaminant	Concentration Carcinogen (ug/kg)	Particulate Emission Factor (m3/kg)	Exposure Frequency (days/yr)	Inhalation Rate (m3/hr)	Exposure Duration (yrs)	Exposure Time (hr/day)	Body Weight (kg)	Average Carc Time (years)	Days per year (day/year)	Inhal Slope Factor (mg/kg-day)-1	Total Lifetime Risk
4,4-DDT	1.9E+09	5.0E+08	350	0.83	30	16	70	70	365	3.40E-01	1.0E-04
Dieldren	4.0E+07	5.0E+08	350	0.83	30	16	70	70	365	1.60E+01	1.0E-04
1,2-Dichloroethene	7.0E+09	5.0E+08	350	0.83	30	16	70	70	365	9.10E-02	1.0E-04
Benzene	2.2E+10	5.0E+08	350	0.83	30	16	70	70	365	2.90E-02	1.0E-04
1,1,2,2-Tetrachloroethane	3.2E+09	5.0E+08	350	0.83	30	16	70	70	365	2.00E-01	1.0E-04
Tetrachloroethane	3.2E+11	5.0E+08	350	0.83	30	16	70	70	365	2.03E-03	1.0E-04
Arsenic	1.3E+07	5.0E+08	350	0.83	30	16	70	70	365	5.00E+01	1.0E-04
Beryllium	7.6E+07	5.0E+08	350	0.83	30	16	70	70	365	8.40E+00	1.0E-04
Cadmium	1.0E+08	5.0E+08	350	0.83	30	16	70	70	365	6.30E+00	1.0E-04
Chromium	1.5E+07	5.0E+08	350	0.83	30	16	70	70	365	4.20E+01	1.0E-04

Contaminant	Concentration Noncarcinogen (ug/kg)	Particulate Emission Factor (m3/kg)	Exposure Frequency (events/yr)	Inhalation Rate (m3/hr)	Exposure Duration (yrs)	Exposure Time (hr/day)	Body Weight (kg)	Average Noncarc Time (years)	Days per year (day/year)	Reference Dose (mg/kg-day)	Hazard Index
Lead	1.4E+10	5.0E+08	350	0.83	30	16	70	30	365	5.00E-03	1
1,4-Dichlorobenzene	2.2E+12	5.0E+08	350	0.83	30	16	70	30	365	8.00E-01	1
Manganese	1.1E+09	5.0E+08	350	0.83	30	16	70	30	365	4.00E-04	1

File Name: PIAL.WQ1

PARTICULATE INHALATION ACTION LEVEL
CHILD RESIDENT

$$C = TR \text{ or } THI * BW * ATc \text{ or } ATnc * DY / CSF \text{ or } 1/RfD * EF * ED * IR * 1/PEF$$

Where:	INPUTS
C = contaminant concentration in soil (ug/kg)	Calculated
TR = total lifetime risk for carcinogen (unitless)	1.0E-04
THI = total Hazard Index for noncarcinogen (unitless)	1
CSF = carcinogenic slope factor	Specific
RfD = reference dose for noncarcinogen	Specific
IR = inhalation rate (m3/hr)	0.43
EF = exposure frequency (days/yr)	350
ET = exposure time (hour/day)	24
ED = exposure duration (years)	6
BW = body weight (kg)	15
ATc = averaging time for carcinogen (yr)	70
ATnc = averaging time for noncarcinogen (yr)	6
DY = day per year (day/yr)	365
PEF = particulate emission factor (m3/kg)	Cowherd

Note: Inputs are scenario and site specific

Contaminant	Concentration Carcinogen (ug/kg)	Particulate Emission Factor (m3/kg)	Exposure Frequency (days/yr)	Inhalation Rate (m3/hr)	Exposure Duration (yrs)	Exposure Time (hr/day)	Body Weight (kg)	Average Carc Time (years)	Days per year (day/year)	Inhal Slope Factor (mg/kg-day) ⁻¹	Total Lifetime Risk
4,4-DDT	2.6E+09	5.0E+08	350	0.43	6	24	15	70	365	3.40E-01	1.0E-04
Dieldren	5.5E+07	5.0E+08	350	0.43	6	24	15	70	365	1.60E+01	1.0E-04
1,2-Dichloroethene	9.7E+09	5.0E+08	350	0.43	6	24	15	70	365	9.10E-02	1.0E-04
Benzene	3.0E+10	5.0E+08	350	0.43	6	24	15	70	365	2.90E-02	1.0E-04
1,1,2,2-Tetrachloroethane	2.1E+10	5.0E+08	350	0.43	6	24	70	70	365	2.00E-01	1.0E-04
Tetrachloroethane	2.0E+12	5.0E+08	350	0.43	6	24	70	70	365	2.03E-03	1.0E-04
Arsenic	1.8E+07	5.0E+08	350	0.43	6	24	15	70	365	5.00E+01	1.0E-04
Beryllium	1.1E+08	5.0E+08	350	0.43	6	24	15	70	365	8.40E+00	1.0E-04
Cadmium	1.4E+08	5.0E+08	350	0.43	6	24	15	70	365	6.30E+00	1.0E-04
Chromium	2.1E+07	5.0E+08	350	0.43	6	24	15	70	365	4.20E+01	1.0E-04

Contaminant	Concentration Noncarcinogen (ug/kg)	Particulate Emission Factor (m3/kg)	Exposure Frequency (events/yr)	Inhalation Rate (m3/hr)	Exposure Duration (yrs)	Exposure Time (hr/day)	Body Weight (kg)	Average Noncarc Time (years)	Days per year (day/year)	Reference Dose (mg/kg-day)	Hazard Index
Lead	3.0E+09	5.0E+08	350	0.43	6	24	15	6	365	5.00E-08	1
1,4-Dichlorobenzene	6.1E+11	5.0E+08	350	0.43	6	24	15	6	365	8.00E-01	1
Manganese	3.0E+08	5.0E+08	350	0.43	6	24	15	6	365	4.00E-04	1

FILE NAME: PIAL.WQ2

PARTICULATE INHALATION ACTION LEVEL
WORKER

$$C = TR \text{ or } THI * BW * ATc \text{ or } ATnc * DY / CSF \text{ or } 1/RfD * EF * ED * IR * 1/PEF$$

Where:	INPUTS
C = contaminant concentration in soil (ug/kg)	Calculated
TR = total lifetime risk for carcinogen (unitless)	1.0E-04
THI = total Hazard Index for noncarcinogen (unitless)	1
CSF = carcinogenic slope factor	Specific
RfD = reference dose for noncarcinogen	Specific
IR = inhalation rate (m3/hr)	1.25
EF = exposure frequency (days/yr)	250
ET = exposure time (hour/day)	8
ED = exposure duration (years)	25
BW = body weight (kg)	70
ATc = averaging time for carcinogen (yr)	70
ATnc = averaging time for noncarcinogen (yr)	25
DY = day per year (day/yr)	365
PEF = particulate emission factor (m3/kg)	Cowherd

Note: Inputs are scenario and site specific

Contaminant	Concentration Carcinogen (ug/kg)	Particulate Emission Factor (m3/kg)	Exposure Frequency (days/yr)	Inhalation Rate (m3/hr)	Exposure Duration (yrs)	Exposure Time (hr/day)	Body Weight (kg)	Average Carc Time (years)	Days per year (day/year)	Inhal Slope Factor (mg/kg-day) ⁻¹	Total Lifetime Risk
4,4-DDT	4.2E+09	5.0E+08	250	1.25	25	8	70	70	365	3.40E-01	1.0E-04
Dieldren	8.9E+07	5.0E+08	250	1.25	25	8	70	70	365	1.60E+01	1.0E-04
1,2-Dichloroethene	1.6E+10	5.0E+08	250	1.25	25	8	70	70	365	9.10E-02	1.0E-04
Benzene	4.9E+10	5.0E+08	250	1.25	25	8	70	70	365	2.90E-02	1.0E-04
1,1,2,2-Tetrachloroethane	7.2E+09	5.0E+08	250	1.25	25	8	70	70	365	2.00E-01	1.0E-04
Tetrachloroethane	7.0E+11	5.0E+08	250	1.25	25	8	70	70	365	2.03E-03	1.0E-04
Arsenic	2.9E+07	5.0E+08	250	1.25	25	8	70	70	365	5.00E+01	1.0E-04
Beryllium	1.7E+08	5.0E+08	250	1.25	25	8	70	70	365	8.40E+00	1.0E-04
Cadmium	2.3E+08	5.0E+08	250	1.25	25	8	70	70	365	6.30E+00	1.0E-04
Chromium	3.4E+07	5.0E+08	250	1.25	25	8	70	70	365	4.20E+01	1.0E-04

Contaminant	Concentration Noncarcinogen (ug/kg)	Particulate Emission Factor (m3/kg)	Exposure Frequency (events/yr)	Inhalation Rate (m3/hr)	Exposure Duration (yrs)	Exposure Time (hr/day)	Body Weight (kg)	Average Noncarc Time (years)	Days per year (day/year)	Reference Dose (mg/kg-day)	Hazard Index
Lead	2.6E+10	5.0E+08	250	1.25	25	8	70	25	365	5.00E-03	1
1,4-Dichlorobenzene	4.1E+12	5.0E+08	250	1.25	25	8	70	25	365	8.00E-01	1
Manganese	2.0E+09	5.0E+08	250	1.25	25	8	70	25	365	4.00E-04	1

FILE NAME: PIAL.WQ3

SOIL INGESTION ACTION LEVEL
ADULT RESIDENT

$$C = TR \text{ or } THI * BW * ATc \text{ or } ATnc * DY / EF * ED * IR * CF * Fi * CSF \text{ or } 1/RfD$$

Where:	INPUTS
C = contaminant concentration in soil (ug/kg)	Calculated
TR = total lifetime carcinogenic risk (unitless)	1E-04
THI = total hazard index (unitless)	1
CF = conversion for kg to mg	1E-06
EF = exposure frequency (days/yr)	350
ED = exposure duration (yr)	30
IR = soil ingestion rate (mg/day)	100
CSF = carcinogenic slope factor	specific
RfD = reference dose	specific
Fi = fraction ingested from source	100
BW = body weight (kg)	70
ATc = averaging time for carcinogen (yr)	70
ATnc = averaging time for noncarcinogen (yr)	30
DY = days per year (days/year)	365

Note: Inputs are scenario and site specific

Contaminant	Concentration Carcinogen (ug/kg)	Exposure Frequency (days/yr)	Exposure Duration (yr)	Ingestion Rate (mg/day)	Body Weight (kg)	Average Carc Time (years)	Conversion Factor (kg/mg)	Days per year (days/yr)	Lifetime Cancer Risk	Slope Factor (mg/kg/day) ⁻¹	Fraction Ingested From Source
4,4'-DDD	709722	350	30	100	70	70	1E-06	365	1E-04	2.40E-01	1
4,4'-DDE	500980	350	30	100	70	70	1E-06	365	1E-04	3.40E-01	1
4,4'-DDT	500980	350	30	100	70	70	1E-06	365	1E-04	3.40E-01	1
Aroclor 1260	22121	350	30	100	70	70	1E-06	365	1E-04	7.70E+00	1
1,4-Dichlorobenzene	7097222	350	30	100	70	70	1E-06	365	1E-04	2.40E-02	1
Benzene	5873563	350	30	100	70	70	1E-06	365	1E-04	2.90E-02	1
1,1,2,2-Tetrachloroethane	851667	350	30	100	70	70	1E-06	365	1E-04	2.00E-01	1
Tetrachloroethane	3275641	350	30	100	70	70	1E-06	365	1E-04	5.20E-02	1
Benzo(a)anthracene	23333	350	30	100	70	70	1E-06	365	1E-04	7.30E+00	1
Benzo(b)fluoranthene	23333	350	30	100	70	70	1E-06	365	1E-04	7.30E+00	1
Bezo(k)fluoranthene	23333	350	30	100	70	70	1E-06	365	1E-04	7.30E+00	1
Benzo(a)pyrene	23333	350	30	100	70	70	1E-06	365	1E-04	7.30E+00	1
Chrysene	23333	350	30	100	70	70	1E-06	365	1E-04	7.30E+00	1
Indeno(123-cd)pyrene	23333	350	30	100	70	70	1E-06	365	1E-04	7.30E+00	1
Arsenic	87333	350	30	100	70	70	1E-06	365	1E-04	1.75E+00	1
Beryllium	39812	350	30	100	70	70	1E-06	365	1E-04	4.30E+00	1

Contaminant	Concentration Noncarcinogen (ug/kg)	Exposure Frequency (days/yr)	Exposure Duration (yr)	Ingestion Rate (mg/day)	Body Weight (kg)	Average Noncarc Time (years)	Conversion Factor (kg/mg)	Days per year (days/yr)	Hazard Index	Reference Dose (mg/kg/day)	Fraction Ingested From Source
4,4'-DDT	365000	350	30	100	70	30	1E-06	365	1	5.00E-04	1
1,1,1-Trichloroethene	85700000	350	30	100	70	30	1E-06	365	1	9.00E-02	1
1,2-Dichloroethene	7300000	350	30	100	70	30	1E-06	365	1	1.00E-02	1
Tetrachloroethane	7300000	350	30	100	70	30	1E-06	365	1	1.00E-02	1
Anthracene	219000000	350	30	100	70	30	1E-06	365	1	3.00E-01	1
Fluoranthene	29200000	350	30	100	70	30	1E-06	365	1	4.00E-02	1
Pyrene	21900000	350	30	100	70	30	1E-06	365	1	3.00E-02	1
Acenaphthene	43800000	350	30	100	70	30	1E-06	365	1	6.00E-02	1
Arsenic	219000	350	30	100	70	30	1E-06	365	1	3.00E-04	1
Barium	51100000	350	30	100	70	30	1E-06	365	1	7.00E-02	1
Beryllium	3650000	350	30	100	70	30	1E-06	365	1	5.00E-03	1
Cadmium	365000	350	30	100	70	30	1E-06	365	1	5.00E-04	1
Chromium	3650000	350	30	100	70	30	1E-06	365	1	5.00E-03	1
Manganese	3650000	350	30	100	70	30	1E-06	365	1	5.00E-03	1
Nickel	14600000	350	30	100	70	30	1E-06	365	1	2.00E-02	1
Zinc	219000000	350	30	100	70	30	1E-06	365	1	3.00E-01	1

SOIL INGESTION ACTION LEVEL
CHILD RESIDENT

$$C = TR \text{ or } THI * BW * ATc \text{ or } ATnc * DY / EF * ED * IR * CF * FI * CSF \text{ or } 1/RfD$$

Where:	INPUTS
C = contaminant concentration in soil (ug/kg)	Calculated
TR = total lifetime carcinogenic risk (unitless)	1E-04
THI = total hazard index (unitless)	1
CF = conversion for kg to mg	1E-06
EF = exposure frequency (days/yr)	350
ED = exposure duration (yr)	6
IR = soil ingestion rate (mg/day)	200
CSF = carcinogenic slope factor	specific
RfD = reference dose	specific
FI = fraction ingested from source	100
BW = body weight (kg)	15
ATc = averaging time for carcinogen (yr)	70
ATnc = averaging time for noncarcinogen (yr)	6
DY = days per year (days/year)	365

Note: Inputs are scenario and site specific

Contaminant	Concentration Carcinogen (ug/kg)	Exposure Frequency (days/yr)	Exposure Duration (yr)	Ingestion Rate (mg/day)	Body Weight (kg)	Average Carc Time (years)	Conversion Factor (kg/mg)	Days per year (days/yr)	Lifetime Cancer Risk	Slope Factor (mg/kg/day)-1	Fraction Ingested From Source
4,4'-DDD	380208	350	6	200	15	70	1E-06	365	1E-04	2.40E-01	1
4,4'-DDE	268382	350	6	200	15	70	1E-06	365	1E-04	3.40E-01	1
4,4'-DDT	268382	350	6	200	15	70	1E-06	365	1E-04	3.40E-01	1
Aroclor 1260	11851	350	6	200	15	70	1E-06	365	1E-04	7.70E+00	1
1,4-Dichlorobenzene	3802083	350	6	200	15	70	1E-06	365	1E-04	2.40E-02	1
Benzene	3146552	350	6	200	15	70	1E-06	365	1E-04	2.90E-02	1
1,1,1,2-Tetrachloroethane	456250	350	6	200	15	70	1E-06	365	1E-04	2.00E-01	1
Tetrachloroethane	1754808	350	6	200	15	70	1E-06	365	1E-04	5.20E-02	1
Benzo(a)anthracene	12500	350	6	200	15	70	1E-06	365	1E-04	7.30E+00	1
Benzo(b)fluoranthene	12500	350	6	200	15	70	1E-06	365	1E-04	7.30E+00	1
Benzo(k)fluoranthene	12500	350	6	200	15	70	1E-06	365	1E-04	7.30E+00	1
Benzo(a)pyrene	12500	350	6	200	15	70	1E-06	365	1E-04	7.30E+00	1
Chrysene	12500	350	6	200	15	70	1E-06	365	1E-04	7.30E+00	1
Indeno(123-cd)pyrene	12500	350	6	200	15	70	1E-06	365	1E-04	7.30E+00	1
Arsenic	52143	350	6	200	15	70	1E-06	365	1E-04	1.75E+00	1
Beryllium	21221	350	6	200	15	70	1E-06	365	1E-04	4.30E+00	1

Contaminant	Concentration Noncarcinogen (ug/kg)	Exposure Frequency (days/yr)	Exposure Duration (yr)	Ingestion Rate (mg/day)	Body Weight (kg)	Average Noncarc Time (years)	Conversion Factor (kg/mg)	Days per year (days/yr)	Hazard Index	Reference Dose (mg/kg/day)	Fraction Ingested From Source
4,4'-DDT	39107	350	6	200	15	6	1E-06	365	1	5.00E-04	1
1,1,1-Trichloroethene	7039286	350	6	200	15	6	1E-06	365	1	9.00E-02	1
1,2-Dichloroethene	782143	350	6	200	15	6	1E-06	365	1	1.00E-02	1
Tetrachloroethane	782143	350	6	200	15	6	1E-06	365	1	1.00E-02	1
Anthracene	23464286	350	6	200	15	6	1E-06	365	1	3.00E-01	1
Fluoranthene	3128571	350	6	200	15	6	1E-06	365	1	4.00E-02	1
Pyrene	2346428	350	6	200	15	6	1E-06	365	1	3.00E-02	1
Acenaphthene	4692857	350	6	200	15	6	1E-06	365	1	6.00E-02	1
Arsenic	23464	350	6	200	15	6	1E-06	365	1	3.00E-04	1
Barium	5475000	350	6	200	15	6	1E-06	365	1	7.00E-02	1
Beryllium	391071	350	6	200	15	6	1E-06	365	1	5.00E-03	1
Cadmium	39107	350	6	200	15	6	1E-06	365	1	5.00E-04	1
Chromium	391071	350	6	200	15	6	1E-06	365	1	5.00E-03	1
Manganese	391071	350	6	200	15	6	1E-06	365	1	5.00E-03	1
Nickel	1564286	350	6	200	15	6	1E-06	365	1	2.00E-02	1
Zinc	23464286	350	6	200	15	6	1E-06	365	1	3.00E-01	1

SOIL INGESTION ACTIVITY LEVEL
WORKER

$$C = TR \text{ or } THI * BW * ATc \text{ or } ATnc * DY / EF * ED * IR * CF * FI * CSF \text{ or } 1/RfD$$

Where:	INPUTS
C = contaminant concentration in soil (ug/kg)	Calculated
TR = total lifetime carcinogenic risk (unitless)	1E-04
THI = total hazard index (unitless)	1
CF = conversion for kg to mg	1E-06
EF = exposure frequency (days/yr)	250
ED = exposure duration (yr)	25
IR = soil ingestion rate (mg/day)	100
CSF = carcinogenic slope factor	specific
RfD = reference dose	specific
FI = fraction ingested from source	100
BW = body weight (kg)	70
ATc = averaging time for carcinogen (yr)	70
ATnc = averaging time for noncarcinogen (yr)	25
DY = days per year (days/year)	365

Note: Inputs are scenario and site specific

Contaminant	Concentration Carcinogen (ug/kg)	Exposure Frequency (days/yr)	Exposure Duration (yr)	Ingestion Rate (mg/day)	Body Weight (kg)	Average Carc Time (years)	Conversion Factor (kg/mg)	Days per year (days/yr)	Lifetime Cancer Risk	Slope Factor (mg/kg/day) ⁻¹	Fraction Ingested From Source
4,4'-DDD	1192333	250	25	100	70	70	1E-06	365	1E-04	2.40E-01	1
4,4'-DDE	841647	250	25	100	70	70	1E-06	365	1E-04	3.40E-01	1
4,4'-DDT	841647	250	25	100	70	70	1E-06	365	1E-04	3.40E-01	1
Aroclor 1260	37164	250	25	100	70	70	1E-06	365	1E-04	7.70E+00	1
1,4-Dichlorobenzene	11923333	250	25	100	70	70	1E-06	365	1E-04	2.40E-02	1
Benzene	9867586	250	25	100	70	70	1E-06	365	1E-04	2.80E-02	1
1,1,2,2-Tetrachloroethane	1430800	250	25	100	70	70	1E-06	365	1E-04	2.00E-01	1
Tetrachloroethane	5503077	250	25	100	70	70	1E-06	365	1E-04	5.20E-02	1
Benzo(a)anthracene	39200	250	25	100	70	70	1E-06	365	1E-04	7.30E+00	1
Benzo(b)fluoranthene	39200	250	25	100	70	70	1E-06	365	1E-04	7.30E+00	1
Benzo(k)fluoranthene	39200	250	25	100	70	70	1E-06	365	1E-04	7.30E+00	1
Benzo(a)pyrene	39200	250	25	100	70	70	1E-06	365	1E-04	7.30E+00	1
Chrysene	39200	250	25	100	70	70	1E-06	365	1E-04	7.30E+00	1
Indeno(123-cd)pyrene	39200	250	25	100	70	70	1E-06	365	1E-04	7.30E+00	1
Arsenic	168329	250	25	100	70	70	1E-06	365	1E-04	1.70E+00	1
Beryllium	66549	250	25	100	70	70	1E-06	365	1E-04	4.30E+00	1

Contaminant	Concentration Noncarcinogen (ug/kg)	Exposure Frequency (days/yr)	Exposure Duration (yr)	Ingestion Rate (mg/day)	Body Weight (kg)	Average Noncarc Time (years)	Conversion Factor (kg/mg)	Days per year (days/yr)	Hazard Index	Reference Dose (mg/kg/day)	Fraction Ingested From Source
4,4'-DDT	511000	250	25	100	70	25	1E-06	365	1	5.00E-04	1
1,1,1-Trichloroethene	91980000	250	25	100	70	25	1E-06	365	1	9.00E-02	1
1,2-Dichloroethene	10220000	250	25	100	70	25	1E-06	365	1	1.00E-02	1
Tetrachloroethane	10220000	250	25	100	70	25	1E-06	365	1	1.00E-02	1
Anthracene	306800000	250	25	100	70	25	1E-06	365	1	3.00E-01	1
Fluoranthene	40880000	250	25	100	70	25	1E-06	365	1	4.00E-02	1
Pyrene	30680000	250	25	100	70	25	1E-06	365	1	3.00E-02	1
Acenaphthene	61320000	250	25	100	70	25	1E-06	365	1	6.00E-02	1
Arsenic	306800	250	25	100	70	25	1E-06	365	1	3.00E-04	1
Barium	71540000	250	25	100	70	25	1E-06	365	1	7.00E-02	1
Beryllium	5110000	250	25	100	70	25	1E-06	365	1	5.00E-03	1
Cadmium	511000	250	25	100	70	25	1E-06	365	1	5.00E-04	1
Chromium	5110000	250	25	100	70	25	1E-06	365	1	5.00E-03	1
Manganese	5110000	250	25	100	70	25	1E-06	365	1	5.00E-03	1
Nickel	20440000	250	25	100	70	25	1E-06	365	1	2.00E-02	1
Zinc	306800000	250	25	100	70	25	1E-06	365	1	3.00E-01	1

File Name: SIALW.WQ1

DERMAL CONTACT WITH SOIL ACTION LEVEL
ADULT RESIDENT

$$C = TR \text{ or } THI * BW * ATc \text{ or } ATnc * DY / CSF \text{ or } RfD * 10E-6 * SA * AF * Abs * ED * EF$$

Where:	INPUTS
C = contaminant concentration in soil (ug/kg)	Calculated
10E-6 = conversion factor (kg/mg)	1E-06
SA = exposed skin surface area (cm2)	5300
AF = soil to skin adherence factor (mg/cm2)	1
Abs = fraction absorbed (unitless) (contaminant specific)	Specific
TR = total lifetime risk for carcinogen (unitless)	1.0E-04
THI = total Hazard Index for noncarcinogen (unitless)	1
CSF = carcinogenic slope factor	Specific
RfD = reference dose for noncarcinogen	Specific
EF = exposure frequency (events/yr)	350
ED = exposure duration (years)	30
BW = body weight (kg)	70
ATc = averaging time for carcinogen (yr)	70
ATnc = averaging time for noncarcinogen (yr)	30
DY = day per year (day/yr)	365

Note: Inputs are scenario and site specific

Contaminant	Concentration Carcinogen (ug/kg)	Conversion Factor (kg/mg)	Surface Area (cm2)	Adherence Factor (mg/cm2)	Fraction Absorbed (%)	Exposure Frequency (events/yr)	Exposure Duration (yrs)	Body Weight (kg)	Average Carc Time (years)	Days per year (day/year)	Slope Factor (mg/kg-day) ⁻¹	Total Lifetime Risk
4,4'-DDD	267819.71	1E-06	5300	1	0.05	350	30	70	70	365	2.40E-01	1.0E-04
4,4'-DDE	189049.20	1E-06	5300	1	0.05	350	30	70	70	365	3.40E-01	1.0E-04
4,4'-DDT	189049.20	1E-06	5300	1	0.05	350	30	70	70	365	3.40E-01	1.0E-04
Aroclor 1260	13912.71	1E-06	5300	1	0.03	350	30	70	70	365	7.70E+00	1.0E-04
1,4-Dichlorobenzene	1339098.53	1E-06	5300	1	0.1	350	30	70	70	365	2.40E-02	1.0E-04
Benzene	1108219.48	1E-06	5300	1	0.1	350	30	70	70	365	2.90E-02	1.0E-04
1,1,2,2-Tetrachloroethane	160691.82	1E-06	5300	1	0.1	350	30	70	70	365	2.00E-01	1.0E-04
Tetrachloroethane	618045.48	1E-06	5300	1	0.1	350	30	70	70	365	5.20E-02	1.0E-04
Benzo(a)anthracene	14675.05	1E-06	5300	1	0.03	350	30	70	70	365	7.30E+00	1.0E-04
Benzo(b)fluoranthene	14675.05	1E-06	5300	1	0.03	350	30	70	70	365	7.30E+00	1.0E-04
Benzo(k)fluoranthene	14675.05	1E-06	5300	1	0.03	350	30	70	70	365	7.30E+00	1.0E-04
Benzo(a)pyrene	14675.05	1E-06	5300	1	0.03	350	30	70	70	365	7.30E+00	1.0E-04
Chrysene	14675.05	1E-06	5300	1	0.03	350	30	70	70	365	7.30E+00	1.0E-04
Indeno(123-cd)pyrene	14675.05	1E-06	5300	1	0.03	350	30	70	70	365	7.30E+00	1.0E-04
Arsenic	163647.80	1E-06	5300	1	0.01	350	30	70	70	365	1.75E+00	1.0E-04
Beryllium	74740.38	1E-06	5300	1	0.01	350	30	70	70	365	4.30E+00	1.0E-04

Contaminant	Concentration Noncarcinogen (ug/kg)	Conversion Factor (kg/mg)	Surface Area (cm2)	Adherence Factor (mg/cm2)	Fraction Absorbed (%)	Exposure Frequency (events/yr)	Exposure Duration (yrs)	Body Weight (kg)	Average Noncarc Time (years)	Days per year (day/year)	Reference Dose (mg/kg-day)	Hazard Index
4,4'-DDT	137735.85	1E-06	5300	1	0.05	350	30	70	30	365	5.00E-04	1
1,1,1-Trichloroethane	12396226.42	1E-06	5300	1	0.1	350	30	70	30	365	9.00E-02	1
1,2-Dichloroethane	1377358.49	1E-06	5300	1	0.1	350	30	70	30	365	1.00E-02	1
Tetrachloroethane	1377358.49	1E-06	5300	1	0.1	350	30	70	30	365	1.00E-02	1
Anthracene	137735848.08	1E-06	5300	1	0.03	350	30	70	30	365	3.00E-01	1
Fluoranthene	18364779.87	1E-06	5300	1	0.03	350	30	70	30	365	4.00E-02	1
Pyrene	13773584.91	1E-06	5300	1	0.03	350	30	70	30	365	3.00E-02	1
Acenaphthene	27547169.81	1E-06	5300	1	0.03	350	30	70	30	365	6.00E-02	1
Arsenic	413207.55	1E-06	5300	1	0.01	350	30	70	30	365	3.00E-04	1
Barium	96415094.34	1E-06	5300	1	0.01	350	30	70	30	365	7.00E-02	1
Beryllium	6886792.45	1E-06	5300	1	0.01	350	30	70	30	365	5.00E-03	1
Cadmium	688679.25	1E-06	5300	1	0.01	350	30	70	30	365	5.00E-04	1
Chromium	6886792.45	1E-06	5300	1	0.01	350	30	70	30	365	5.00E-03	1
Manganese	6886792.45	1E-06	5300	1	0.01	350	30	70	30	365	5.00E-03	1
Nickel	27547169.81	1E-06	5300	1	0.01	350	30	70	30	365	2.00E-02	1
Zinc	413207547.17	1E-06	5300	1	0.01	350	30	70	30	365	3.00E-01	1

DERMAL CONTACT WITH SOIL ACTION LEVEL
CHILD RESIDENT

$$C = TR \text{ or } THI * BW * ATc \text{ or } ATnc * DY / CSF \text{ or } RfD * 10E-6 * SA * AF * Abs * ED * EF$$

Where:	INPUTS
C = contaminant concentration in soil (ug/kg)	Calculated
10E-6 = conversion factor (kg/mg)	1E-06
SA = exposed skin surface area (cm2)	1800
AF = soil to skin adherence factor (mg/cm2)	1
Abs = fraction absorbed (unitless) (contaminant specific)	Specific
TR = total lifetime risk for carcinogen (unitless)	1.0E-04
THI = total Hazard Index for noncarcinogen (unitless)	1
CSF = carcinogenic slope factor	Specific
RfD = reference dose for noncarcinogen	Specific
EF = exposure frequency (events/yr)	350
ED = exposure duration (years)	6
BW = body weight (kg)	15
ATc = averaging time for carcinogen (yr)	70
ATnc = averaging time for noncarcinogen (yr)	6
DY = day per year (day/yr)	365

Note: Inputs are scenario and site specific

Contaminant	Concentration Carcinogen (ug/kg)	Conversion Factor (kg/mg)	Surface Area (cm2)	Adherence Factor (mg/cm2)	Fraction Absorbed (%)	Exposure Frequency (events/yr)	Exposure Duration (yrs)	Body Weight (kg)	Average Carc Time (years)	Days per year (day/year)	Slope Factor (mg/kg-day) ⁻¹	Total Lifetime Risk
4,4'-DDD	844907.41	1E-06	1800	1	0.05	350	6	15	70	365	2.40E-01	1.0E-04
4,4'-DDE	596405.23	1E-06	1800	1	0.05	350	6	15	70	365	3.40E-01	1.0E-04
4,4'-DDT	596405.23	1E-06	1800	1	0.05	350	6	15	70	365	3.40E-01	1.0E-04
Aroclor 1260	43891.29	1E-06	1800	1	0.03	350	6	15	70	365	7.70E+00	1.0E-04
1,4-Dichlorobenzene	4224537.04	1E-06	1800	1	0.1	350	6	15	70	365	2.40E-02	1.0E-04
Benzene	3496168.58	1E-06	1800	1	0.1	350	6	15	70	365	2.90E-02	1.0E-04
1,1,2,2-Tetrachloroethane	506944.44	1E-06	1800	1	0.1	350	6	15	70	365	2.00E-01	1.0E-04
Tetrachloroethane	1949786.32	1E-06	1800	1	0.1	350	6	15	70	365	5.20E-02	1.0E-04
Benzo(a)anthracene	46296.30	1E-06	1800	1	0.03	350	6	15	70	365	7.30E+00	1.0E-04
Benzo(b)fluoranthene	46296.30	1E-06	1800	1	0.03	350	6	15	70	365	7.30E+00	1.0E-04
Benzo(k)fluoranthene	46296.30	1E-06	1800	1	0.03	350	6	15	70	365	7.30E+00	1.0E-04
Benzo(a)pyrene	46296.30	1E-06	1800	1	0.03	350	6	15	70	365	7.30E+00	1.0E-04
Chrysene	46296.30	1E-06	1800	1	0.03	350	6	15	70	365	7.30E+00	1.0E-04
Indeno(123-cd)pyrene	46296.30	1E-06	1800	1	0.03	350	6	15	70	365	7.30E+00	1.0E-04
Arsenic	579365.08	1E-06	1800	1	0.01	350	6	15	70	365	1.75E+00	1.0E-04
Beryllium	235788.11	1E-06	1800	1	0.01	350	6	15	70	365	4.30E+00	1.0E-04

Contaminant	Concentration Noncarcinogen (ug/kg)	Conversion Factor (kg/mg)	Surface Area (cm2)	Adherence Factor (mg/cm2)	Fraction Absorbed (%)	Exposure Frequency (events/yr)	Exposure Duration (yrs)	Body Weight (kg)	Average Noncarc Time (years)	Days per year (day/year)	Reference Dose (mg/kg-day)	Hazard Index
4,4'-DDT	86904.76	1E-06	1800	1	0.05	350	6	15	6	365	5.00E-04	1
1,1,1-Trichloroethane	7821428.57	1E-06	1800	1	0.1	350	6	15	6	365	9.00E-02	1
1,2-Dichloroethane	869047.62	1E-06	1800	1	0.1	350	6	15	6	365	1.00E-02	1
Tetrachloroethane	869047.62	1E-06	1800	1	0.1	350	6	15	6	365	1.00E-02	1
Anthracene	86904761.90	1E-06	1800	1	0.03	350	6	15	6	365	3.00E-01	1
Fluoranthene	11587301.59	1E-06	1800	1	0.03	350	6	15	6	365	4.00E-02	1
Pyrene	8690476.19	1E-06	1800	1	0.03	350	6	15	6	365	3.00E-02	1
Acenaphthene	17380952.38	1E-06	1800	1	0.03	350	6	15	6	365	6.00E-02	1
Arsenic	260714.29	1E-06	1800	1	0.01	350	6	15	6	365	3.00E-04	1
Barium	60833333.33	1E-06	1800	1	0.01	350	6	15	6	365	7.00E-02	1
Beryllium	4345238.10	1E-06	1800	1	0.01	350	6	15	6	365	5.00E-03	1
Cadmium	434523.81	1E-06	1800	1	0.01	350	6	15	6	365	5.00E-04	1
Chromium	4345238.10	1E-06	1800	1	0.01	350	6	15	6	365	5.00E-03	1
Manganese	4345238.10	1E-06	1800	1	0.01	350	6	15	6	365	5.00E-03	1
Nickel	17380952.38	1E-06	1800	1	0.01	350	6	15	6	365	2.00E-02	1
Zinc	260714285.71	1E-06	1800	1	0.01	350	6	15	6	365	3.00E-01	1

DERMAL CONTACT WITH ACTION LEVEL
WORKER

$$C = TR \text{ or } THI * BW * ATc \text{ or } ATnc * DY / CSF \text{ or } RfD * 10E-6 * SA * AF * Abs * ED * EF$$

Where:	INPUTS
C = contaminant concentration in soil (ug/kg)	Calculated
10E-6 = conversion factor (kg/mg)	1E-06
SA = exposed skin surface area (cm ²)	4300
AF = soil to skin adherence factor (mg/cm ²)	1
Abs = fraction absorbed (unitless) (contaminant specific)	Specific
TR = total lifetime risk for carcinogen (unitless)	1.0E-04
THI = total Hazard Index for noncarcinogen (unitless)	1
CSF = carcinogenic slope factor	Specific
RfD = reference dose for noncarcinogen	Specific
EF = exposure frequency (events/yr)	250
ED = exposure duration (years)	25
BW = body weight (kg)	70
ATc = averaging time for carcinogen (yr)	70
ATnc = averaging time for noncarcinogen (yr)	25
DY = day per year (day/yr)	365

Note: Inputs are scenario and site specific

Contaminant	Concentration Carcinogen (ug/kg)	Conversion Factor (kg/mg)	Surface Area (cm ²)	Adherence Factor (mg/cm ²)	Fraction Absorbed (%)	Exposure Frequency (events/yr)	Exposure Duration (yrs)	Body Weight (kg)	Average Carc Time (years)	Days per year (day/year)	Slope Factor (mg/kg-day) ⁻¹	Total Lifetime Risk
4,4'-DDD	554573.64	1E-06	4300	1	0.05	250	25	70	70	365	2.40E-01	1.0E-04
4,4'-DDE	391463.75	1E-06	4300	1	0.05	250	25	70	70	365	3.40E-01	1.0E-04
4,4'-DDT	391463.75	1E-06	4300	1	0.05	250	25	70	70	365	3.40E-01	1.0E-04
Aroclor 1260	28809.02	1E-06	4300	1	0.03	250	25	70	70	365	7.70E+00	1.0E-04
1,4-Dichlorobenzene	2772868.22	1E-06	4300	1	0.1	250	25	70	70	365	2.40E-02	1.0E-04
Benzene	2294787.49	1E-06	4300	1	0.1	250	25	70	70	365	2.90E-02	1.0E-04
1,1,2,2-Tetrachloroethane	332744.19	1E-06	4300	1	0.1	250	25	70	70	365	2.00E-01	1.0E-04
Tetrachloroethane	1279785.33	1E-06	4300	1	0.1	250	25	70	70	365	5.20E-02	1.0E-04
Benzo(a)anthracene	30387.60	1E-06	4300	1	0.03	250	25	70	70	365	7.30E+00	1.0E-04
Benzo(b)fluoranthene	30387.60	1E-06	4300	1	0.03	250	25	70	70	365	7.30E+00	1.0E-04
Benzo(k)fluoranthene	30387.60	1E-06	4300	1	0.03	250	25	70	70	365	7.30E+00	1.0E-04
Benzo(a)pyrene	30387.60	1E-06	4300	1	0.03	250	25	70	70	365	7.30E+00	1.0E-04
Chrysene	30387.60	1E-06	4300	1	0.03	250	25	70	70	365	7.30E+00	1.0E-04
Indeno(123-cd)pyrene	30387.60	1E-06	4300	1	0.03	250	25	70	70	365	7.30E+00	1.0E-04
Arsenic	38027.91	1E-06	4300	1	0.1	250	25	70	70	365	1.75E+00	1.0E-04
Beryllium	154764.74	1E-06	4300	1	0.01	250	25	70	70	365	4.30E+00	1.0E-04

Contaminant	Concentration Noncarcinogen (ug/kg)	Conversion Factor (kg/mg)	Surface Area (cm ²)	Adherence Factor (mg/cm ²)	Fraction Absorbed (%)	Exposure Frequency (events/yr)	Exposure Duration (yrs)	Body Weight (kg)	Average Noncarc Time (years)	Days per year (day/year)	Reference Dose (mg/kg-day)	Hazard Index
4,4'-DDT	237674.42	1E-06	4300	1	0.05	250	25	70	25	365	5.00E-04	1
1,1,1-Trichloroethane	21390697.67	1E-06	4300	1	0.1	250	25	70	25	365	9.00E-02	1
1,2-Dichloroethane	2376744.19	1E-06	4300	1	0.1	250	25	70	25	365	1.00E-02	1
Tetrachloroethane	2376744.19	1E-06	4300	1	0.1	250	25	70	25	365	1.00E-02	1
Anthracene	237674418.60	1E-06	4300	1	0.03	250	25	70	25	365	3.00E-01	1
Fluoranthene	31689922.48	1E-06	4300	1	0.03	250	25	70	25	365	4.00E-02	1
Pyrene	23767441.86	1E-06	4300	1	0.03	250	25	70	25	365	3.00E-02	1
Acenaphthene	47534863.72	1E-06	4300	1	0.03	250	25	70	25	365	6.00E-02	1
Arsenic	713023.26	1E-06	4300	1	0.01	250	25	70	25	365	3.00E-04	1
Barium	166372083.02	1E-06	4300	1	0.01	250	25	70	25	365	7.00E-02	1
Beryllium	11883720.93	1E-06	4300	1	0.01	250	25	70	25	365	5.00E-03	1
Cadmium	11883720.93	1E-06	4300	1	0.01	250	25	70	25	365	5.00E-04	1
Chromium	11883720.93	1E-06	4300	1	0.01	250	25	70	25	365	5.00E-03	1
Manganese	11883720.93	1E-06	4300	1	0.01	250	25	70	25	365	5.00E-03	1
Nickel	47534863.72	1E-06	4300	1	0.01	250	25	70	25	365	2.00E-02	1
Zinc	713023255.81	1E-06	4300	1	0.01	250	25	70	25	365	3.00E-01	1

INGESTION OF GROUNDWATER ACTION LEVEL
ADULT RESIDENT

$$C = TR \text{ or } THI * BW * ATc \text{ or } ATnc * DY / IRw * EF * ED * CSF \text{ or } 1/RfD$$

Where:	INPUTS
C = contaminant concentration in water ((ug/L)	
TR = total lifetime risk	1E-04
THI = total hazard index	1
CSF = carcinogenic slope factor	specific
RfD = reference dose	specific
IRw = daily water ingestion rate (L/Day)	2
EF = exposure frequency (days/yr)	350
ED = exposure duration (yr)	30
BW = body weight (kg)	70
ATc = averaging time for carcinogen (yr)	70
ATnc = averaging time for noncarcinogen (yr)	30
DY = days per year (day/year)	365

Note: Inputs are scenario and site specific

Contaminant	Concentration Carcinogen (ug/l)	Ingestion Rate (L/day)	Exposure Frequency (day/year)	Exposure Duration (year)	Body Weight (kg)	Average Carc Time (years)	Days per year (day/yr)	Slope Factor (mg/kg-day) ⁻¹	Target Excess Risk
Bromodichloromethane	137	2	350	30	70	70	365	6.20E-02	1.0E-04
1,2-Dichloroethane	94	2	350	30	70	70	365	9.10E-02	1.0E-04
1,1-Dichloroethene	14	2	350	30	70	70	365	6.00E-01	1.0E-04
1,1,2,2-Tetrachloroethane	43	2	350	30	70	70	365	2.00E-01	1.0E-04
1,1,2-Trichloroethane	149	2	350	30	70	70	365	5.70E-02	1.0E-04
Trichloroethene	774	2	350	30	70	70	365	1.10E-02	1.0E-04
Tetrachloroethane	164	2	350	30	70	70	365	5.20E-02	1.0E-04
Vinyl Chloride	4	2	350	30	70	70	365	1.90E+00	1.0E-04
Arsenic	5	2	350	30	70	70	365	1.75E+00	1.0E-04
Beryllium	2	2	350	30	70	70	365	4.30E+00	1.0E-04

Contaminant	Concentration Noncarcinogen (ug/L)	Ingestion Rate (L/day)	Exposure Frequency (day/year)	Exposure Duration (year)	Body Weight (kg)	Average Noncarc Time (years)	Days per year (day/yr)	Reference Dose (mg/kg-day)	Target Hazard Index
Bromodichloromethane	730	2	350	30	70	30	365	2.00E-02	1
Chlorobenzene	730	2	350	30	70	30	365	2.00E-02	1
1,1-Dichloroethene	328	2	350	30	70	30	365	9.00E-03	1
Tetrachloroethene	365	2	350	30	70	30	365	1.00E-02	1
1,1,2-Trichloroethane	146	2	350	30	70	30	365	4.00E-03	1
Ethylbenzene	3650	2	350	30	70	30	365	1.00E-01	1
Total Xylene	73000	2	350	30	70	30	365	2.00E+00	1
Arsenic	11	2	350	30	70	30	365	3.00E-04	1
Barium	2555	2	350	30	70	30	365	7.00E-02	1
Beryllium	183	2	350	30	70	30	365	5.00E-03	1
Chromium	183	2	350	30	70	30	365	5.00E-03	1
Manganese	183	2	350	30	70	30	365	5.00E-03	1
Nickel	730	2	350	30	70	30	365	2.00E-02	1
Zinc	10950	2	350	30	70	30	365	3.00E-01	1

INGESTION OF GROUNDWATER ACTION LEVEL
CHILD RESIDENT

$$C = TR \text{ or } THI * BW * ATc \text{ or } ATnc * DY / IRw * EF * ED * CSF \text{ or } 1/RfD$$

Where:	INPUTS
C = contaminant concentration in water (ug/L)	
TR = total lifetime risk	1E-04
THI = total hazard index	1
CSF = carcinogenic slope factor	specific
RfD = reference dose	specific
IRw = daily water ingestion rate (L/Day)	1
EF = exposure frequency (days/yr)	350
ED = exposure duration (yr)	6
BW = body weight (kg)	15
ATc = averaging time for carcinogen (yr)	70
ATnc = averaging time for noncarcinogen (yr)	6
DY = days per year (day/year)	365

Note: Inputs are scenario and site specific

Contaminant	Concentration Carcinogen (ug/l)	Ingestion Rate (L/day)	Exposure Frequency (day/year)	Exposure Duration (year)	Body Weight (kg)	Average Carc Time (years)	Days per year (day/yr)	Slope Factor (mg/kg-day) ⁻¹	Target Excess Risk
Bromodichloromethane	294	1	350	6	15	70	365	6.20E-02	1.0E-04
1,2-Dichloroethane	201	1	350	6	15	70	365	9.10E-02	1.0E-04
1,1-Dichloroethene	30	1	350	6	15	70	365	6.00E-01	1.0E-04
1,1,2,2-Tetrachloroethane	91	1	350	6	15	70	365	2.00E-01	1.0E-04
1,1,2-Trichloroethane	320	1	350	6	15	70	365	5.70E-02	1.0E-04
Trichloroethene	1659	1	350	6	15	70	365	1.10E-02	1.0E-04
Tetrachloroethane	351	1	350	6	15	70	365	5.20E-02	1.0E-04
Vinyl Chloride	10	1	350	6	15	70	365	1.90E+00	1.0E-04
Arsenic	10	1	350	6	15	70	365	1.75E+00	1.0E-04
Beryllium	4	1	350	6	15	70	365	4.30E+00	1.0E-04

Contaminant	Concentration Noncarcinogen (ug/L)	Ingestion Rate (L/day)	Exposure Frequency (day/year)	Exposure Duration (year)	Body Weight (kg)	Average Noncarc Time (years)	Days per year (day/yr)	Reference Dose (mg/kg-day)	Target Hazard Index
Bromodichloromethane	313	1	350	6	15	6	365	2.00E-02	1
Chlorobenzene	313	1	350	6	15	6	365	2.00E-02	1
1,1-Dichloroethene	141	1	350	6	15	6	365	9.00E-03	1
Tetrachloroethene	156	1	350	6	15	6	365	1.00E-02	1
1,1,2-Trichloroethane	63	1	350	6	15	6	365	4.00E-03	1
Ethylbenzene	1584	1	350	6	15	6	365	1.00E-01	1
Total Xylene	31286	1	350	6	15	6	365	2.00E+00	1
Arsenic	5	1	350	6	15	6	365	3.00E-04	1
Barium	1095	1	350	6	15	6	365	7.00E-02	1
Beryllium	78	1	350	6	15	6	365	5.00E-03	1
Chromium	78	1	350	6	15	6	365	5.00E-03	1
Manganese	78	1	350	6	15	6	365	5.00E-03	1
Nickel	313	1	350	6	15	6	365	2.00E-02	1
Zinc	4693	1	350	6	15	6	365	3.00E-01	1

INGESTION OF GROUNDWATER ACTION LEVEL
WORKER

$$C = TR \text{ or } THI * BW * ATc \text{ or } ATnc * DY / IRw * EF * ED * CSF \text{ or } 1/RfD$$

Where:

INPUTS

C = contaminant concentration in water (ug/L)	
TR = total lifetime risk	1E-04
THI = total hazard index	1
CSF = carcinogenic slope factor	specific
RfD = reference dose	specific
IRw = daily water ingestion rate (L/Day)	2
EF = exposure frequency (days/yr)	250
ED = exposure duration (yr)	25
BW = body weight (kg)	70
ATc = averaging time for carcinogen (yr)	70
ATnc = averaging time for noncarcinogen (yr)	25
DY = days per year (day/year)	365

Note: Inputs are scenario and site specific

Contaminant	Concentration Carcinogen (ug/l)	Ingestion Rate (L/day)	Exposure Frequency (day/year)	Exposure Duration (year)	Body Weight (kg)	Average Carc Time (years)	Days per year (day/yr)	Slope Factor (mg/kg-day) ⁻¹	Target Excess Risk
Bromodichloromethane	231	2	250	25	70	70	365	6.20E-02	1.0E-04
1,2-Dichloroethane	157	2	250	25	70	70	365	9.10E-02	1.0E-04
1,1-Dichloroethene	24	2	250	25	70	70	365	6.00E-01	1.0E-04
1,1,2,2-Tetrachloroethane	72	2	250	25	70	70	365	2.00E-01	1.0E-04
1,1,2-Trichloroethane	251	2	250	25	70	70	365	5.70E-02	1.0E-04
Trichloroethene	1301	2	250	25	70	70	365	1.10E-02	1.0E-04
Tetrachloroethene	275	2	250	25	70	70	365	5.20E-02	1.0E-04
Vinyl Chloride	8	2	250	25	70	70	365	1.90E+00	1.0E-04
Arsenic	8	2	250	25	70	70	365	1.75E+00	1.0E-04
Beryllium	3	2	250	25	70	70	365	4.30E+00	1.0E-04

Contaminant	Concentration Noncarcinogen (ug/L)	Ingestion Rate (L/day)	Exposure Frequency (day/year)	Exposure Duration (year)	Body Weight (kg)	Average Noncarc Time (years)	Days per year (day/yr)	Reference Dose (mg/kg-day)	Target Hazard Index
Bromodichloromethane	1022	2	250	25	70	25	365	2.00E-02	1
Chlorobenzene	1022	2	250	25	70	25	365	2.00E-02	1
1,1-Dichloroethene	460	2	250	25	70	25	365	9.00E-03	1
Tetrachloroethene	511	2	250	25	70	25	365	1.00E-02	1
1,1,2-Trichloroethane	204	2	250	25	70	25	365	4.00E-03	1
Ethlbenzene	5110	2	250	25	70	25	365	1.00E-01	1
Total Xylene	102200	2	250	25	70	25	365	2.00E+00	1
Arsenic	15	2	250	25	70	25	365	3.00E-04	1
Barium	3577	2	250	25	70	25	365	7.00E-02	1
Beryllium	256	2	250	25	70	25	365	5.00E-03	1
Chromium	256	2	250	25	70	25	365	5.00E-03	1
Manganese	256	2	250	25	70	25	365	5.00E-03	1
Nickel	1022	2	250	25	70	25	365	2.00E-02	1
Zinc	15330	2	250	25	70	25	365	3.00E-01	1

**APPENDIX C
REMEDIAL ACTION ALTERNATIVE
COST ESTIMATES**

TABLE C-1

DETAIL COSTING EVALUATION

GROUNDWATER REMEDIAL ACTION ALTERNATIVE NO. 2

LIMITED ACTION

O & M COST ESTIMATE

20-Aug-93

COST COMPONENT	UNIT	QUANTITY	UNIT COST	SUBTOTAL COST	TOTAL COST	BASIS OR COMMENTS	SOURCE
Groundwater Monitoring							
Labor	Hours	288	\$35	\$10,080		24 wells sampled semiannually. 2 samplers; 3 hrs/well average	Engineering estimate
Laboratory Analysis - TCL VOA	Sample	48	\$375	\$18,000		24 samples; semiannually	Basic Ordering Agreement
Misc. Expenses	Sample Event	2	\$2,500	\$5,000		Incl. travel, lodging, supplies, - 2 people	Engineering estimate
Reporting	Sample Event	2	\$3,000	\$6,000		1 report per sampling event	Engineering estimate
					\$39,080		
Total Annual O&M Costs					\$39,080	For 30 years	
Approximate Present Worth Value					\$600,000		

TABLE C-2

DETAIL COSTING EVALUATION

GROUNDWATER REMEDIAL ACTION ALTERNATIVE NO. 3
CONTAINMENT

CAPITAL COST ESTIMATE

20-Aug-93

COST COMPONENT	UNIT	QUANTITY	UNIT COST	SUBTOTAL COST	TOTAL COST	BASIS OR COMMENTS	SOURCE
Mobilization							
Equipment	Lump Sum	1	\$15,000	\$15,000			Previous Estimate
Miscellaneous	Lump Sum	1	\$10,000	\$10,000		Utilities hook-up, site preparation	Previous Estimate
					\$25,000		
Groundwater Extraction System							
Driller Mobilization	Lump Sum	1	\$3,000	\$3,000			Basic Ordering Agreement
Extraction Well - Deep (6)	Per Foot	660	\$450	\$297,000		6" stainless steel, 110' deep	Engineering Estimate
Extraction Well - Shallow (6)	Per Foot	210	\$450	\$94,500		6" stainless steel, 25' deep	Engineering Estimate
Well Development	Per Well	12	\$375	\$4,500			Engineering Estimate
Extraction Pump at 12 Wells	Per Pump	12	\$9,500	\$114,000			Engineering Estimate
Piping From Wells	Per Foot	6700	\$60	\$402,000		Stainless steel pipe w/tench	Basic Ordering Agreement
					\$915,000		
Pretreatment System	Lump Sum	1	\$250,000	\$250,000		Inorganics removal	Previous Estimates
Physical/Chemical Treatment System							
Air Stripper	Lump Sum	1	\$170,000	\$170,000		Towers, blowers, electric, pumps, etc.	Previous Estimates
Carbon Adsorption	Lump Sum	1	\$220,000	\$220,000		Carbon units, pumps, electric, etc.	Previous Estimates
Misc. Equipment	Lump Sum	1	\$70,000	\$70,000		Sludge dewatering press, holding tank	Previous Estimates
Treatment Building	Lump Sum	1	\$250,000	\$250,000		60 ft. by 60 ft.	Previous Estimates
					\$960,000		
Discharge of Treated Water							
Surface Infrastructure	Per Foot	1200	\$1	\$1,200		Power conduits, piping	Engineering Estimate
Effluent Pump	Per Pump	1	\$2,600	\$2,600			Engineering Estimate
Discharge Piping	Per Foot	2400	\$10	\$24,000			Engineering Estimate
					\$27,800		
Demobilization							
Administrative Activities	Lump Sum	1	\$10,000	\$10,000		Administrative reporting, etc.	Previous Estimate
Site Restoration	Lump Sum	1	\$5,000	\$5,000		General site cleanup, revegetation, etc.	Engineering Estimate
Equipment	Lump Sum	1	\$2,000	\$2,000			Engineering Estimate
					\$17,000		
Subtotal Capital Cost					\$1,944,800		
Engineering @ 10%				\$194,480			
Contingencies @ 20%				\$388,960			
Pilot Studies @ 5%				\$97,240			
Total Capital Costs					\$2,625,480		

TABLE C-2 (continued)
DETAIL COSTING EVALUATION
 GROUNDWATER REMEDIAL ACTION ALTERNATIVE NO. 3
 CONTAINMENT

O & M COST ESTIMATE 20-Aug-93

COST COMPONENT	UNIT	QUANTITY	UNIT COST	SUBTOTAL COST	TOTAL COST	BASIS OR COMMENTS	SOURCE
Groundwater Monitoring							
Labor	Hours	288	\$35	\$10,080		24 wells sampled semiannually. 2 samplers; 3 hrs/well average	Engineering estimate
Laboratory Analysis - TCL VOA	Sample	48	\$375	\$18,000		24 samples; semiannually	Basic Ordering Agreement
Misc. Expenses	Sample Event	2	\$2,500	\$5,000		Incl. travel, lodging, supplies,- 2 people	Engineering estimate
Reporting	Sample Event	2	\$3,000	\$6,000		1 report per sampling event	Engineering estimate
					\$39,080		
System Operation and Maintenance							
Electricity	Per Year	1	\$50,000	\$50,000		Pretreatment, treatment, building	Previous Estimate
Materials	Per Year	1	\$45,000	\$45,000		Chemicals, polymer, etc.	Previous Estimate
Material Handling	Per Year	1	\$45,000	\$45,000		spent carbon, sludge disposal	Previous Estimate
Operating Labor	Per Year	1	\$54,750	\$54,750		Approx. 5 hours/day @ \$30.00/hr	Previous Estimate
Maintenance Labor	Per Year	1	\$14,400	\$14,400		Approx. 40 hours/month @ \$30.00/hr	Previous Estimate
Administration	Per Year	1	\$5,000	\$5,000			Previous Estimate
					\$214,150		
Effluent Sampling							
Labor	Hours	96	\$35	\$3,360		8 hours/month	Engineering Estimate
Laboratory Analysis - TCL VOA	Sample	56	\$375	\$21,000		Samples: 1/week + 1/quarter	Engineering Estimate
Reporting	Per Quarter	4	\$2,000	\$8,000		Lab reports, etc (1 report/quarter)	Engineering Estimate
					\$32,360		
Total Annual O&M Costs					\$285,590	For 30 years	
Approximate Present Worth Value					\$7,000,000		

TABLE C-3

DETAIL COSTING EVALUATION

GROUNDWATER REMEDIAL ACTION ALTERNATIVE NO. 4
INTENSIVE GROUNDWATER EXTRACTION AND TREATMENT

CAPITAL COST ESTIMATE

20-Aug-93

COST COMPONENT	UNIT	QUANTITY	UNIT COST	SUBTOTAL COST	TOTAL COST	BASIS OR COMMENTS	SOURCE
Mobilization							
Equipment	Lump Sum	1	\$15,000	\$15,000			Previous Estimate
Miscellaneous	Lump Sum	1	\$10,000	\$10,000		Utilities hook-up, site preparation	Previous Estimate
					\$25,000		
Groundwater Extraction System							
Driller Mobilization	Lump Sum	1	\$3,000	\$3,000			Basic Ordering Agreement
Extraction Well - Deep (2)	Per Foot	220	\$450	\$99,000		6" stainless steel, 110' deep	Engineering Estimate
Extraction Well - Shallow (3)	Per Foot	105	\$450	\$47,250		6" stainless steel, 25' deep	Engineering Estimate
Well Development	Per Well	5	\$375	\$1,875			Engineering Estimate
Extraction Pumps	Per Pump	5	\$9,500	\$47,500			Engineering Estimate
Piping From Wells	Per Foot	1930	\$60	\$115,800		Stainless steel pipe w/tench	Basic Ordering Agreement
					\$314,425		
Pretreatment System	Lump Sum	1	\$175,000	\$175,000		Inorganics removal	Previous Estimates
Physical/Chemical Treatment System							
Air Stripper	Lump Sum	1	\$120,000	\$120,000		Towers, blowers, electric, pumps, etc.	Previous Estimates
Carbon Adsorption	Lump Sum	1	\$155,000	\$155,000		Carbon units, pumps, electric, etc.	Previous Estimates
Misc. Equipment	Lump Sum	1	\$50,000	\$50,000		Sludge dewatering press, holding tank	Previous Estimates
Treatment Building	Lump Sum	1	\$175,000	\$175,000		60 ft. by 60 ft.	Previous Estimates
					\$675,000		
Discharge of Treated Water							
Surface Infrastructure	Per Foot	1200	\$1	\$1,200		Power conduits, piping	Engineering Estimate
Effluent Pump	Per Pump	1	\$2,600	\$2,600			Engineering Estimate
Discharge Piping	Per Foot	2400	\$10	\$24,000			Engineering Estimate
					\$27,800		
Demobilization							
Administrative Activities	Lump Sum	1	\$10,000	\$10,000		Administrative reporting, etc.	Previous Estimate
Site Restoration	Lump Sum	1	\$5,000	\$5,000		General site cleanup, revegetation, etc.	Engineering Estimate
Equipment	Lump Sum	1	\$2,000	\$2,000			Engineering Estimate
					\$17,000		
Subtotal Capital Cost					\$1,059,225		
Engineering @ 10%				\$105,923			
Contingencies @ 20%				\$211,845			
Pilot Studies @ 5%				\$52,961			
Total Capital Costs					\$1,429,954		

TABLE C-3 (continued)

DETAIL COSTING EVALUATION

GROUNDWATER REMEDIAL ACTION ALTERNATIVE NO. 4
INTENSIVE GROUNDWATER EXTRACTION AND TREATMENT

O & M COST ESTIMATE

20-Aug-93

COST COMPONENT	UNIT	QUANTITY	UNIT COST	SUBTOTAL COST	TOTAL COST	BASIS OR COMMENTS	SOURCE
Groundwater Monitoring							
Labor	Hours	288	\$35	\$10,080		24 wells sampled semiannually.	Engineering estimate
Laboratory Analysis - TCL VOA	Sample	48	\$375	\$18,000		2 samplers; 3 hrs/well average	Basic Ordering Agreement
Misc. Expenses	Sample Event	2	\$2,500	\$5,000		24 samples; semiannually	Engineering estimate
Reporting	Sample Event	2	\$3,000	\$6,000		Incl. travel, lodging, supplies, - 2 people	Engineering estimate
					\$39,080	1 report per sampling event	Engineering estimate
System Operation and Maintenance							
Electricity	Per Year	1	\$35,000	\$35,000		Pretreatment, treatment, building	Previous Estimate
Materials	Per Year	1	\$31,500	\$31,500		Chemicals, polymer, etc.	Previous Estimate
Material Handling	Per Year	1	\$31,500	\$31,500		spent carbon, sludge disposal	Previous Estimate
Operating Labor	Per Year	1	\$43,800	\$43,800		Approx. 4 hours/day @ \$30.00/hr	Previous Estimate
Maintenance Labor	Per Year	1	\$8,640	\$8,640		Approx. 24 hours/month @ \$30.00/hr	Previous Estimate
Administration	Per Year	1	\$5,000	\$5,000			Previous Estimate
					\$155,440		
Effluent Sampling							
Labor	Hours	96	\$35	\$3,360		8 hours/month	Engineering Estimate
Laboratory Analysis - TCL VOA	Sample	56	\$375	\$21,000		Samples: 1/week + 1/quarter	Engineering Estimate
Reporting	Per Quarter	4	\$2,000	\$8,000		Lab reports, etc (1 report/quarter)	Engineering Estimate
					\$32,360		
Total Annual O&M Costs					\$226,880	For 30 years	
Approximate Present Worth Value					\$4,900,000		

TABLE C-4

DETAIL COSTING EVALUATION

GROUNDWATER REMEDIAL ACTION ALTERNATIVE NO. 5
GROUNDWATER EXTRACTION AND TREATMENT

CAPITAL COST ESTIMATE

20-Aug-93

COST COMPONENT	UNIT	QUANTITY	UNIT COST	SUBTOTAL COST	TOTAL COST	BASIS OR COMMENTS	SOURCE
Mobilization							
Equipment	Lump Sum	1	\$15,000	\$15,000			Previous Estimate
Miscellaneous	Lump Sum	1	\$10,000	\$10,000		Utilities hook-up, site preparation	Previous Estimate
					\$25,000		
Groundwater Extraction System							
Driller Mobilization	Lump Sum	1	\$3,000	\$3,000			Basic Ordering Agreement
Extraction Well - Deep (8)	Per Foot	880	\$450	\$396,000		6" stainless steel, 110' deep	Engineering Estimate
Extraction Well - Shallow (12)	Per Foot	420	\$450	\$189,000		6" stainless steel, 25' deep	Engineering Estimate
Well Development	Per Well	20	\$375	\$7,500			Engineering Estimate
Extraction Pumps	Per Pump	20	\$9,500	\$190,000			Engineering Estimate
Piping From Wells	Per Foot	7100	\$60	\$426,000		Stainless steel pipe w/tench	Basic Ordering Agreement
					\$1,211,500		
Pretreatment System	Lump Sum	1	\$350,000	\$350,000		Inorganics removal	Previous Estimates
Physical/Chemical Treatment System							
Air Stripper	Lump Sum	1	\$240,000	\$240,000		Towers, blowers, electric, pumps, etc.	Previous Estimates
Carbon Adsorption	Lump Sum	1	\$310,000	\$310,000		Carbon units, pumps, electric, etc.	Previous Estimates
Misc. Equipment	Lump Sum	1	\$100,000	\$100,000		Sludge dewatering press, holding tank	Previous Estimates
Treatment Building	Lump Sum	1	\$300,000	\$300,000		60 ft. by 60 ft.	Previous Estimates
					\$1,300,000		
Discharge of Treated Water							
Surface Infrastructure	Per Foot	1200	\$1	\$1,200		Power conduits, piping	Engineering Estimate
Effluent Pump	Per Pump	1	\$2,600	\$2,600			Engineering Estimate
Discharge Piping	Per Foot	2400	\$10	\$24,000			Engineering Estimate
					\$27,800		
Demobilization							
Administrative Activities	Lump Sum	1	\$10,000	\$10,000		Administrative reporting, etc.	Previous Estimate
Site Restoration	Lump Sum	1	\$5,000	\$5,000		General site cleanup, revegetation, etc.	Engineering Estimate
Equipment	Lump Sum	1	\$2,000	\$2,000			Engineering Estimate
					\$17,000		
Subtotal Capital Cost					\$2,581,300		
Engineering @ 10%				\$258,130			
Contingencies @ 20%				\$516,260			
Pilot Studies @ 5%				\$129,065			
Total Capital Costs					\$3,484,755		

TABLE C-4 (continued)

DETAIL COSTING EVALUATION

GROUNDWATER REMEDIAL ACTION ALTERNATIVE NO. 5
GROUNDWATER EXTRACTION AND TREATMENT

O & M COST ESTIMATE

20-Aug-93

COST COMPONENT	UNIT	QUANTITY	UNIT COST	SUBTOTAL COST	TOTAL COST	BASIS OR COMMENTS	SOURCE
Groundwater Monitoring							
Labor	Hours	288	\$35	\$10,080		24 wells sampled semiannually.	Engineering estimate
Laboratory Analysis - TCL VOA	Sample	48	\$375	\$18,000		2 samplers; 3 hrs/well average	Basic Ordering Agreement
Misc. Expenses	Sample Event	2	\$2,500	\$5,000		24 samples; semiannually	Engineering estimate
Reporting	Sample Event	2	\$3,000	\$6,000		Incl. travel, lodging, supplies, - 2 people	Engineering estimate
					\$39,080	1 report per sampling event	
System Operation and Maintenance							
Electricity	Per Year	1	\$70,000	\$70,000		Pretreatment, treatment, building	Previous Estimate
Materials	Per Year	1	\$63,000	\$63,000		Chemicals, polymer, etc.	Previous Estimate
Material Handling	Per Year	1	\$63,000	\$63,000		Spent carbon, sludge disposal	Previous Estimate
Operating Labor	Per Year	1	\$65,700	\$65,700		Approx. 6 hours/day @ \$30.00/hr	Previous Estimate
Maintenance Labor	Per Year	1	\$17,280	\$17,280		Approx. 48 hours/month @ \$30.00/hr	Previous Estimate
Administration	Per Year	1	\$5,000	\$5,000			Previous Estimate
					\$283,980		
Effluent Sampling							
Labor	Hours	96	\$35	\$3,360		8 hours/month	Engineering Estimate
Laboratory Analysis - TCL VOA	Sample	56	\$375	\$21,000		Samples: 1/week + 1/quarter	Engineering Estimate
Reporting	Per Quarter	4	\$2,000	\$8,000		Lab reports, etc (1 report/quarter)	Engineering Estimate
					\$32,360		
Total Annual O&M Costs					\$355,420	For 30 years	
Approximate Present Worth Value					\$8,900,000		

TABLE C-5

DETAIL COSTING EVALUATION

SOIL REMEDIAL ACTION ALTERNATIVE No. 2

CAPPING

CAPITAL COST ESTIMATE 20-Aug-93

COST COMPONENT	UNIT	QUANTITY	UNIT COST	SUBTOTAL COST	TOTAL COST	BASIS OR COMMENTS	SOURCE
Site Preparation							
Equipment Mobilization	Lump Sum	1	\$15,000	\$15,000	\$34,000	Excavation and cap equipment All AOC and Cap Areas Utilities, site support operations	Previous estimates MEANS 1993, p. 29 Previous estimates
Site Clearing	Acre	9	\$1,000	\$9,000			
Miscellaneous Mobilization	Lump Sum	1	\$10,000	\$10,000			
Access Restrictions							
Fencing	Per Foot	2200	\$12	\$26,400	\$26,760	Cyclone fencing	Means 1993, p. 96 Engineering estimate
Signage	Each	6	\$60	\$360			
Multilayered Cap							
Excavation and Loading	Cubic Yard	19000	\$15.00	\$285,000	\$1,784,500	To a depth of 2 or 4 feet Hauling within Operable Unit No. 2 1 sample/100 cy excavated soil Cap is 400 feet x 700 feet	Previous estimates Previous estimates Previous estimates Previous estimates
On-Site Hauling	Cubic Yard	19000	\$6.00	\$114,000			
Confirmation Sampling	Per Sample	190	\$450	\$85,500			
Cap	Acre	6.5	\$200,000	\$1,300,000			
Site Restoration							
Fill and Compact	Cubic Yard	19000	\$10.00	\$190,000	\$204,530	Excavated areas Excavated and Cap Areas Excavated and Cap Areas General site cleanup and close out	Engineering estimate NAVFAC CES Means, 1993, p. 106 Engineering estimate
Grading	Square Yard	15500	\$0.45	\$6,975			
Revegetation	MSF	140	\$18.25	\$2,555			
Miscellaneous	Lump Sum	1	\$5,000	\$5,000			
Demobilization							
Administrative Activities	Lump Sum	1	\$5,000	\$5,000	\$7,000	Reporting, etc. Excavation and cap equipment	Previous estimates Engineering estimate
Equipment	Lump Sum	1	\$2,000	\$2,000			
Subtotal Capital Cost					\$2,056,790		
Engineering @ 10%				\$205,679			
Contingencies @ 20%				\$411,358			
Pilot Studies @ 5%				\$102,840			
Total Capital Cost					\$2,776,667		

TABLE C-5 (continued)
 DETAIL COSTING EVALUATION
 SOIL REMEDIAL ACTION ALTERNATIVE No. 2
 CAPPING

O & M COST ESTIMATE 20-Aug-93

COST COMPONENT	UNIT	QUANTITY	UNIT COST	SUBTOTAL COST	TOTAL COST	BASIS OR COMMENTS	SOURCE
Cap Maintenance							
Replace Topsoil	Cubic Yard	524	\$15	\$7,860		Assume 6" over 1/10 of capped area Assume 1/10 of capped area	
Revegetate	MSF	28	\$18	\$511			
Inspection	Lump Sum	1	\$6,000	\$6,000			
					\$14,371		
Groundwater Monitoring							
Labor	Hours	40	\$35.00	\$1,400		Semi-annual sampling of 6 wells Based on 2 sampling personnel Semi-annual sampling of 6 wells	Engineering Estimate
Laboratory Analyses							
-CLP VOA	Analyses	6	\$375.00	\$4,500			Basic Ordering Agreement
-CLP SVOA	Analyses	6	\$585.00	\$7,020			Basic Ordering Agreement
-CLP Metals	Analyses	6	\$339.00	\$4,068			Basic Ordering Agreement
Miscellaneous Expenses	Sample Event	1	\$2,000.00	\$4,000		Incl. travel, lodging, supplies 1 report per sampling event	Engineering estimate
Reporting	Report	1	\$1,500.00	\$3,000			Previous estimates
					\$23,988		
Total Capital Costs					\$2,776,667		
Total Annual O & M Costs					\$38,359	For 30 years	
Approximate Present Worth Value					\$3,400,000		

TABLE C-6A
 DETAIL COSTING EVALUATION

SOIL REMEDIAL ACTION ALTERNATIVE No. 3
 ON-SITE TREATMENT (Incineration for all AOCs)

CAPITAL COST ESTIMATE 20-Aug-93

COST COMPONENT	UNIT	QUANTITY	UNIT COST	SUBTOTAL COST	TOTAL COST	BASIS OR COMMENTS	SOURCE
Site Preparation							
Equipment Mobilization	Lump Sum	1	\$15,000	\$15,000		Excavation and cap equipment	Previous estimates
Site Clearing	Acre	3.2	\$1,000	\$3,200		All AOC Areas	MEANS 1993, p. 29
Miscellaneous Mobilization	Lump Sum	1	\$10,000	\$10,000		Utilities, site support operations	Previous estimates
					\$28,200		
Access Restrictions							
Fencing	Per Foot	1500	\$12	\$18,000		Cyclone fencing	Means 1993, p. 96
Signage	Each	6	\$60	\$360			Engineering estimate
					\$18,360		
Incineration							
Excavation and Loading	Cubic Yard	19000	\$15.00	\$285,000		To a depth of 2 or 4 feet	Previous estimates
On-Site Hauling	Cubic Yard	19000	\$6.00	\$114,000		Hauling within Operable Unit No. 2	Previous estimates
Confirmation Sampling	Per Sample	190	\$450	\$85,500		1 sample/100 cy excavated soil	Previous estimates
Incineration	Ton	27700	\$150.00	\$4,155,000		Assume soil density 108 lb/cf and operation	Previous Estimate
					\$4,639,500		
Monitoring							
Ash Testing	Per Sample	20	\$170.00	\$3,400		Previous estimates	
					\$3,400		
Site Restoration							
Fill and Compact	Cubic Yard	19000	\$10.00	\$190,000		Excavated areas	Engineering estimate
Grading	Square Yard	15500	\$0.45	\$6,975		Excavated Areas	NAVFAC CES
Revegetation	MSF	140	\$18.25	\$2,555		Excavated Areas	Means, 1993, p. 106
Miscellaneous	Lump Sum	1	\$5,000	\$5,000		General site cleanup and close out	Engineering estimate
					\$204,530		
Demobilization							
Administrative Activities	Lump Sum	1	\$5,000	\$5,000		Reporting, etc.	Previous estimates
Equipment	Lump Sum	1	\$2,000	\$2,000		Excavation and cap equipment	Engineering estimate
					\$7,000		
Subtotal Capital Cost					\$4,900,990		
Engineering @ 10%				\$490,099			
Contingencies @ 20%				\$980,198			
Pilot Studies @ 5%				\$245,050			
Total Capital Cost					\$6,616,337		

Approximate Present Worth Value: \$6,600,000

TABLE C-6B

DETAIL COSTING EVALUATION

SOIL REMEDIAL ACTION ALTERNATIVE No. 3

Land Treatment for AOCs 1, 2 and 5; Incineration for Remaining AOCs

CAPITAL COST ESTIMATE

20-Aug-93

COST COMPONENT	UNIT	QUANTITY	UNIT COST	SUBTOTAL COST	TOTAL COST	BASIS OR COMMENTS	SOURCE
Site Preparation							
Equipment Mobilization	Lump Sum	1	\$15,000	\$15,000		Excavation and treatment equipment All AOC Areas Utilities, site support operations	Previous estimates
Site Clearing	Acre	3.2	\$1,000	\$3,200			MEANS 1993, p. 29
Miscellaneous Mobilization	Lump Sum	1	\$10,000	\$10,000	\$28,200		Previous estimates
Access Restrictions							
Fencing	Per Foot	1500	\$12	\$18,000		Cyclone fencing	Means 1993, p. 96 Engineering estimate
Signage	Each	6	\$60	\$360	\$18,360		
Treatment Preparation							
Excavation and Loading	Cubic Yard	19000	\$15.00	\$285,000		To a depth of 2 or 4 feet Hauling within Operable Unit No. 2 1 sample/100 cy excavated soil	Previous estimates
On-Site Hauling	Cubic Yard	19000	\$6.00	\$114,000			Previous estimates
Confirmation Sampling	Per Sample	190	\$450	\$85,500	\$484,500		Previous estimates
Incineration	Ton	1166	\$150.00	\$174,900	\$174,900	Assume soil density 108 lb/cf	Previous Estimate
Land Treatment	Cubic Yard	18200	\$40.00	\$728,000	\$728,000	Incl. earthwork, fertilizers, testing and decontamination	Previous estimates
Site Restoration							
Fill and Compact	Cubic Yard	19000	\$10.00	\$190,000		Excavated areas Excavated areas Excavated areas General site cleanup and close out	Engineering estimate
Grading	Square Yard	15500	\$0.45	\$6,975			NAVFAC CES
Revegetation	MSF	140	\$18.25	\$2,555			Means, 1993, p. 106
Miscellaneous	Lump Sum	1	\$5,000	\$5,000	\$204,530		Engineering estimate
Demobilization							
Administrative Activities	Lump Sum	1	\$5,000	\$5,000		Reporting, etc. Excavation and cap equipment	Previous estimates
Equipment	Lump Sum	1	\$2,000	\$2,000	\$7,000		Engineering estimate
Subtotal Capital Cost					\$1,645,490		
Engineering @ 10%				\$164,549			
Contingencies @ 20%				\$329,098			
Pilot Studies @ 5%				\$82,275			
Total Capital Cost					\$2,221,412		

TABLE C-6B (continued)
 DETAIL COSTING EVALUATION

SOIL REMEDIAL ACTION ALTERNATIVE No. 3

Land Treatment for AOCs 1, 2 and 5; Incineration for Remaining AOCs

O & M COST ESTIMATE

20-Aug-93

COST COMPONENT	UNIT	QUANTITY	UNIT COST	SUBTOTAL COST	TOTAL COST	BASIS OR COMMENTS	SOURCE
Land Treatment	cy	18200	\$18	\$327,600	\$327,600	Estimated to be 3 years	
Total Capital Costs					\$2,221,412		
Total Annual O & M Costs					\$327,600	For 3 years	
Approximate Present Worth Value					\$3,100,000		

TABLE C-6C

DETAIL COSTING EVALUATION

SOIL REMEDIAL ACTION ALTERNATIVE No. 3

In Situ Treatment for AOC 1; Incineration for Remaining AOCs

CAPITAL COST ESTIMATE

20-Aug-93

COST COMPONENT	UNIT	QUANTITY	UNIT COST	SUBTOTAL COST	TOTAL COST	BASIS OR COMMENTS	SOURCE
Site Preparation							
Equipment Mobilization	Lump Sum	1	\$15,000	\$15,000		Excavation and cap equipment	Previous estimates
Site Clearing	Acre	3.2	\$1,000	\$3,200		All AOC Areas	MEANS 1993, p. 29
Miscellaneous Mobilization	Lump Sum	1	\$10,000	\$10,000		Utilities, site support operations	Previous estimates
					\$28,200		
Access Restrictions							
Fencing	Per Foot	1500	\$12	\$18,000		Cyclone fencing	Means 1993, p. 96
Signage	Each	6	\$60	\$360			Engineering estimate
					\$18,360		
Treatment Preparation							
Excavation and Loading	Cubic Yard	2500	\$15.00	\$37,500		To a depth of 2 feet	Previous estimates
On-Site Hauling	Cubic Yard	2500	\$6.00	\$15,000		Hauling within Operable Unit No. 2	Previous estimates
Confirmation Sampling	Per Sample	25	\$450	\$11,250		1 sample/100 cy excavated soil	Previous estimates
					\$63,750		
In Situ Volatilization	Cubic Yard	16500	\$20.00	\$330,000		For AOC 1 only	Testa, 1991
Confirmation Sampling	Per Sample	165	\$450	\$74,250		1 sample/100 excavated soil to identify the edge of contamination	Previous estimates
					\$404,250		
Incineration	Ton	3645	\$150	\$546,750		AOCs 3, 4 and 6	EPA/540/6-90/007
					\$546,750		
Site Restoration							
Fill and Compact	Cubic Yard	2500	\$10.00	\$25,000		Excavated areas	Engineering estimate
Grading	Square Yard	3400	\$0.45	\$1,530		Excavated and Cap Areas	NAVFAC CES
Revegetation	MSF	140	\$18.25	\$2,555		Excavated and Cap Areas	Means, 1993, p. 106
Miscellaneous	Lump Sum	1	\$5,000	\$5,000		General site cleanup and close out	Engineering estimate
					\$34,085		
Demobilization							
Administrative Activities	Lump Sum	1	\$5,000	\$5,000		Reporting, etc.	Previous estimates
Equipment	Lump Sum	1	\$2,000	\$2,000		Excavation and cap equipment	Engineering estimate
					\$7,000		
Subtotal Capital Cost					\$1,102,395		
Engineering @ 10%				\$110,240			
Contingencies @ 20%				\$220,479			
Pilot Studies @ 5%				\$55,120			
Total Capital Cost					\$1,488,233		

TABLE C-6D (continued)

DETAIL COSTING EVALUATION

SOIL REMEDIAL ACTION ALTERNATIVE No. 3

In Situ Treatment for AOC 1; Land Treatment for AOCs 2 and 5; Chemical Dechlorination for AOCs 3, 4 and 6

O & M COST ESTIMATE

20-Aug-93

COST COMPONENT	UNIT	QUANTITY	UNIT COST	SUBTOTAL COST	TOTAL COST	BASIS OR COMMENTS	SOURCE
In Situ Volatilization	Year	1	\$50,000	\$50,000	\$50,000	Incl. electric, monitoring and labor Estimated to be 5 years	Previous estimate
Total Capital Costs					\$1,488,233		
Total Annual O & M Costs					\$50,000	For 5 years	
Approximate Present Worth Value					\$1,700,000		

TABLE C-6D

DETAIL COSTING EVALUATION

SOIL REMEDIAL ACTION ALTERNATIVE No. 3

In Situ Treatment for AOC 1; Land Treatment for AOCs 2 and 5; Chemical Dechlorination for AOCs 3, 4 and 6

CAPITAL COST ESTIMATE 20-Aug-93

COST COMPONENT	UNIT	QUANTITY	UNIT COST	SUBTOTAL COST	TOTAL COST	BASIS OR COMMENTS	SOURCE
Site Preparation							
Equipment Mobilization	Lump Sum	1	\$15,000	\$15,000		Excavation and cap equipment	Previous estimates
Site Clearing	Acre	3.2	\$1,000	\$3,200		All AOC Areas	MEANS 1993, p. 29
Miscellaneous Mobilization	Lump Sum	1	\$10,000	\$10,000		Utilities, site support operations	Previous estimates
					\$28,200		
Access Restrictions							
Fencing	Per Foot	1500	\$12	\$18,000		Cyclone fencing	Means 1993, p. 96
Signage	Each	6	\$60	\$360			Engineering estimate
					\$18,360		
Treatment Preparation							
Excavation and Loading	Cubic Yard	2500	\$15.00	\$37,500		To a depth of 2 feet	Previous estimates
On-Site Hauling	Cubic Yard	2500	\$6.00	\$15,000		Hauling within Operable Unit No. 2	Previous estimates
Confirmation Sampling	Per Sample	25	\$450	\$11,250		1 sample/100 cy excavated soil	Previous estimates
					\$63,750		
Land Treatment	Cubic Yard	1700	\$50.00	\$85,000		Incl. earthwork, fertilizer, testing and decontamination	Previous estimate
					\$85,000		
In Situ Volatilization	Cubic Yard	16500	\$20.00	\$330,000		For AOC 1 only	Testa, 1991
Confirmation Sampling	Per Sample	165	\$450	\$74,250		1 sample/100 excavated soil to identify the edge of contamination	Previous estimates
					\$404,250		
Chemical Dechlorination	Cubic Yard	800	\$800	\$640,000		AOCs 3, 4 and 6	EPA/540/6-90/007
					\$640,000		
Site Restoration							
Fill and Compact	Cubic Yard	2500	\$10.00	\$25,000		Excavated areas	Engineering estimate
Grading	Square Yard	3400	\$0.45	\$1,530		Excavated and Cap Areas	NAVFAC CES
Revegetation	MSF	140	\$18.25	\$2,555		Excavated and Cap Areas	Means, 1993, p. 106
Miscellaneous	Lump Sum	1	\$5,000	\$5,000		General site cleanup and close out	Engineering estimate
					\$34,085		
Demobilization							
Administrative Activities	Lump Sum	1	\$5,000	\$5,000		Reporting, etc.	Previous estimates
Equipment	Lump Sum	1	\$2,000	\$2,000		Excavation and cap equipment	Engineering estimate
					\$7,000		
Subtotal Capital Cost					\$1,280,645		
Engineering @ 10%				\$128,065			
Contingencies @ 20%				\$256,129			
Pilot Studies @ 5%				\$64,032			
Total Capital Cost					\$1,728,871		

TABLE C-6D (continued)
 DETAIL COSTING EVALUATION

SOIL REMEDIAL ACTION ALTERNATIVE No. 3

In Situ Treatment for AOC 1; Land Treatment for AOCs 2 and 5; Chemical Dechlorination for AOCs 3, 4 and 6

O & M COST ESTIMATE

20-Aug-93

COST COMPONENT	UNIT	QUANTITY	UNIT COST	SUBTOTAL COST	TOTAL COST	BASIS OR COMMENTS	SOURCE
In Situ Volatilization - 5 Year	Year	1	\$50,000	\$50,000	\$50,000.00	incl. electric, monitoring and labor Includes sampling	Previous estimate
Land Treatment - 3 Year	Cubic Yard	1700	\$18	\$30,600			
					\$30,600.00		
Chemical Dechlorination - 3 Years						Approximately 1% of treatment cost	
Oversite	Month	12	1600	\$19,200			
Materials	Year	1	18000	\$18,000			
Total Capital Costs					\$1,728,871		
Annual O & M Costs					\$80,600	For Years 1-3	
Annual O & M Costs					\$50,000	For Years 4-5	
Approximate Present Worth Value					\$2,000,000		

TABLE C-7
 DETAIL COSTING EVALUATION

SOIL REMEDIAL ACTION ALTERNATIVE No. 4
 PARTIAL CAPPING, PARTIAL ON-SITE TREATMENT (All Areas of Concern)

CAPITAL COST ESTIMATE 20-Aug-93

COST COMPONENT	UNIT	QUANTITY	UNIT COST	SUBTOTAL COST	TOTAL COST	BASIS OR COMMENTS	SOURCE
Site Preparation							
Equipment Mobilization	Lump Sum	1	\$15,000	\$15,000		Excavation and cap equipment	Previous estimates
Site Clearing	Acre	4.2	\$1,000	\$4,200		All AOC and cap areas	MEANS 1993, p. 29
Miscellaneous Mobilization	Lump Sum	1	\$10,000	\$10,000		Utilities, site support operations	Previous estimates
					\$29,200		
Access Restrictions							
Fencing	Per Foot	1500	\$12	\$18,000		Cyclone fencing	Means 1993, p. 96
Signage	Each	6	\$60	\$360			Engineering estimate
					\$18,360		
Treatment Preparation							
Excavation and Loading	Cubic Yard	2500	\$15.00	\$37,500		To depths of 2 and 4 feet	Previous estimates
On-Site Hauling	Cubic Yard	2500	\$6.00	\$15,000		Hauling within Operable Unit No. 2	Previous estimates
Confirmation Sampling	Per Sample	25	\$450	\$11,250		1 sample/100 cy excavated soil	Previous estimates
					\$63,750		
Land Treatment	Cubic Yard	1700	\$50.00	\$85,000		Incl. earthwork, fertilizer, testing and decontamination: AOCs 2 & 5	Previous estimate
					\$85,000		
In Situ Volatilization	Cubic Yard	16500	\$20.00	\$330,000		For AOC 1 only	Testa, 1991
Confirmation Sampling	Per Sample	165	\$450	\$74,250		1 sample/100 excavated soil to identify the edge of contamination	Previous estimates
					\$404,250		
Cap for PCB Contaminated Soils	Acre	1	\$45,000.00	\$45,000		AOCs 3, 4 and 6, incl. geomembrane and vegetated cover	EPA/540/6-90/007
					\$45,000		
Site Restoration							
Fill and Compact	Cubic Yard	2500	\$10.00	\$25,000		Excavated areas	Engineering estimate
Grading	Square Yard	3420	\$0.45	\$1,539		Excavated and Cap Areas	NAVFAC CES
Revegetation	MSF	140	\$18.25	\$2,555		Excavated and Cap Areas	Means, 1993, p. 106
Miscellaneous	Lump Sum	1	\$5,000	\$5,000		General site cleanup and close out	Engineering estimate
					\$34,094		
Demobilization							
Administrative Activities	Lump Sum	1	\$5,000	\$5,000		Reporting, etc.	Previous estimates
Equipment	Lump Sum	1	\$2,000	\$2,000		Excavation and cap equipment	Engineering estimate
					\$7,000		
Subtotal Capital Cost					\$686,654		
Engineering @ 10%				\$68,665			
Contingencies @ 20%				\$137,331			
Pilot Studies @ 5%				\$34,333			
Total Capital Cost					\$926,983		

TABLE C-7 (continued)
 DETAIL COSTING EVALUATION
 SOIL REMEDIAL ACTION ALTERNATIVE No. 4
 PARTIAL CAPPING, PARTIAL ON-SITE TREATMENT

O & M COST ESTIMATE 20-Aug-93

COST COMPONENT	UNIT	QUANTITY	UNIT COST	SUBTOTAL COST	TOTAL COST	BASIS OR COMMENTS	SOURCE
Maintenance							
Replace Topsoil	Cubic Yard	74	\$15	\$1,110		6" of 1/10 of capped area 1/10 of capped area	
Revegetate	MSF	4	18.25	\$73			
Inspection	Lump Sum	1	\$6,000	\$6,000			
					\$7,183.00		
In Situ Volatilization	Year	1	\$50,000	\$50,000		Incl. electric, monitoring & labor	
					\$50,000		
Groundwater Monitoring						Semi-annual sampling of 6 wells Based on 2 sampling personnel Semi-annual sampling of 6 wells	Engineering Estimate
Labor	Hours	40	\$35.00	\$1,400			
Laboratory Analyses							
-CLP VOA	Analyses	6	\$375.00	\$4,500			Basic Ordering Agreement
-CLP SVOA	Analyses	6	\$585.00	\$7,020			Basic Ordering Agreement
-CLP Metals	Analyses	6	\$339.00	\$4,068			Basic Ordering Agreement
Miscellaneous Expenses	Sample Event	1	\$2,000.00	\$4,000		Incl. travel, lodging, supplies 1 report per sampling event	Engineering estimate
Reporting	Report	1	\$1,500.00	\$3,000			Previous estimates
					\$23,988.00		
Total Capital Costs					\$926,983		
Annual O & M Costs					\$81,171.00	For Years 1-5	
Annual O & M Costs					\$31,171	For Years 6-30	
Approximate Present Worth Value					\$1,600,000		

TABLE C-8A
 DETAIL COSTING EVALUATION
 SOIL REMEDIAL ACTION ALTERNATIVE No. 5A
 OFF-SITE DISPOSAL

CAPITAL COST ESTIMATE 20-Aug-93

COST COMPONENT	UNIT	QUANTITY	UNIT COST	SUBTOTAL COST	TOTAL COST	BASIS OR COMMENTS	SOURCE
Site Preparation							
Equipment Mobilization	Lump Sum	1	\$15,000	\$15,000		Excavation and treatment equipment All AOCs: 140,000 SF Utilities hook up, site preparation	Previous estimates
Site Clearing	Acre	3.2	\$1,000	\$3,200			Previous estimates
Miscellaneous	Lump Sum	1	\$10,000	\$10,000	\$28,200		Previous estimates
Off-Site Landfill							
Excavation and Loading	Cubic Yard	19000	\$20.00	\$380,000		AOCs 2 through 6 1 sample/100 cy excavated soil Based on 25 cy/truck Landfill in Pinewood, SC	Previous estimates
Confirmation Sampling	Per Sample	190	\$450	\$85,500			Previous estimates
Transportation (200 miles one way)	Loaded Mile	152000	\$3	\$456,000			Means, 1993, p. 26
Disposal (Nonhazardous)	Ton	27700	\$110	\$3,047,000	\$3,968,500		Vendor Quote
Site Restoration							
Fill and Compact	Cubic Yard	19000	\$5.00	\$95,000		Excavated areas Excavated areas All disturbed (cleared) areas General site cleanup	Engineering estimate
Grading	Square Yard	15500	\$0.45	\$6,975			NAVFAC CES
Revegetation	MSF	140	\$18.25	\$2,555			Means, 1993, p. 106
Miscellaneous	Lump Sum	1	\$5,000	\$5,000	\$109,530		Engineering estimate
Demobilization							
Administrative Activities	Lump Sum	1	\$5,000	\$5,000		Reporting, etc.	Previous estimates
Equipment	Lump Sum	1	\$2,000	\$2,000	\$7,000		Engineering estimate
Subtotal Capital Cost					\$4,113,230		
Engineering @ 10%				\$411,323			
Contingencies @ 20%				\$822,646			
Pilot Studies @ 5%				\$205,662			
Total Capital Cost					\$5,552,861		

TABLE C-8B
 DETAIL COSTING EVALUATION
 SOIL REMEDIAL ACTION ALTERNATIVE No. 5B
 OFF-SITE TREATMENT

CAPITAL COST ESTIMATE 20-Aug-93

COST COMPONENT	UNIT	QUANTITY	UNIT COST	SUBTOTAL COST	TOTAL COST	BASIS OR COMMENTS	SOURCE
Site Preparation							
Equipment Mobilization	Lump Sum	1	\$15,000	\$15,000		Excavation and treatment equipment All AOCs: 140,000 SF Utilities hook up, site preparation	Previous estimates
Site Clearing	Acre	3.2	\$1,000	\$3,200			Previous estimates
Miscellaneous	Lump Sum	1	\$10,000	\$10,000	\$28,200		Previous estimates
Off-Site TSDF							
Excavation and Loading	Cubic Yard	19000	\$20.00	\$380,000		AOCs 2 through 6 1 sample/100 cy excavated soil Based on 25 cy/truck Permitted TSDF	Previous estimates
Confirmation Sampling	Per Sample	190	\$450	\$85,500			Previous estimates
Transportation (300 miles one way)	Loaded Mile	228000	\$3	\$684,000			Means, 1993, p. 26
Treatment	Ton	27700	\$500	\$13,850,000	\$14,999,500		Previous estimates
Site Restoration							
Fill and Compact	Cubic Yard	19000	\$5.00	\$95,000		Excavated areas Excavated areas All disturbed (cleared) areas General site cleanup	Engineering estimate
Grading	Square Yard	15500	\$0.45	\$6,975			NAVFAC CES
Revegetation	MSF	140	\$18.25	\$2,555			Means, 1993, p. 106
Miscellaneous	Lump Sum	1	\$5,000	\$5,000	\$109,530		Engineering estimate
Demobilization							
Administrative Activities	Lump Sum	1	\$5,000	\$5,000		Reporting, etc.	Previous estimates
Equipment	Lump Sum	1	\$2,000	\$2,000	\$7,000		Engineering estimate
Subtotal Capital Cost					\$15,144,230		
Engineering @ 10%				\$1,514,423			
Contingencies @ 20%				\$3,028,846			
Pilot Studies @ 5%				\$757,212			
Total Capital Cost					\$20,444,711		

TABLE C-9

DETAIL COSTING EVALUATION

SOIL REMEDIAL ACTION ALTERNATIVE No. 6

PARTIAL CAPPING, PARTIAL ON-SITE TREATMENT (Limited Areas of Concern)

CAPITAL COST ESTIMATE

20-Aug-93

COST COMPONENT	UNIT	QUANTITY	UNIT COST	SUBTOTAL COST	TOTAL COST	BASIS OR COMMENTS	SOURCE
Site Preparation							
Equipment Mobilization	Lump Sum	1	\$15,000	\$15,000		Excavation and cap equipment All AOC and cap areas Utilities, site support operations	Previous estimates
Site Clearing	Acre	3.6	\$1,000	\$3,600			MEANS 1993, p. 29
Miscellaneous Mobilization	Lump Sum	1	\$10,000	\$10,000			Previous estimates
					\$28,600		
Access Restrictions							
Fencing	Per Foot	1500	\$12	\$18,000		Cyclone fencing	Means 1993, p. 96 Engineering estimate
Signage	Each	6	\$60	\$360			
					\$18,360		
Treatment Preparation							
Excavation and Loading	Cubic Yard	400	\$15.00	\$6,000		To depths of 2 and 4 feet Hauling within Operable Unit No. 2 1 sample/100 cy excavated soil	Previous estimates
On-Site Hauling	Cubic Yard	400	\$6.00	\$2,400			Previous estimates
Confirmation Sampling	Per Sample	4	\$450	\$1,800			Previous estimates
					\$10,200		
In Situ Volatilization	Cubic Yard	16500	\$20.00	\$330,000		For AOC 1 only 1 sample/100 excavated soil to identify the edge of contamination	Testa, 1991 Previous estimates
Confirmation Sampling	Per Sample	165	\$450	\$74,250			
					\$404,250		
Soil Cap for PCB Contaminated Soils	Acre	1	\$45,000.00	\$45,000		AOCs 4 and 5, incl. geomembrane and vegetated cover	EPA/540/6-90/007
					\$45,000		
Site Restoration							
Fill and Compact	Cubic Yard	400	\$10.00	\$4,000		Excavated areas Excavated and Cap Areas Excavated and Cap Areas General site cleanup and close out	Engineering estimate
Grading	Square Yard	600	\$0.45	\$270			NAVFAC CES
Revegetation	MSF	160	\$18.25	\$2,920			Means, 1993, p. 106
Miscellaneous	Lump Sum	1	\$5,000	\$5,000			Engineering estimate
					\$12,190		
Demobilization							
Administrative Activities	Lump Sum	1	\$5,000	\$5,000		Reporting, etc. Excavation and cap equipment	Previous estimates
Equipment	Lump Sum	1	\$2,000	\$2,000			Engineering estimate
					\$7,000		
Subtotal Capital Cost					\$525,600		
Engineering @ 10%				\$52,560			
Contingencies @ 20%				\$105,120			
Pilot Studies @ 5%				\$26,280			
Total Capital Cost					\$709,560		

TABLE C-9 (continued)
 DETAIL COSTING EVALUATION

SOIL REMEDIAL ACTION ALTERNATIVE No. 6
 PARTIAL CAPPING, PARTIAL ON-SITE TREATMENT (Limited Areas of Concern)

O & M COST ESTIMATE 20-Aug-93

COST COMPONENT	UNIT	QUANTITY	UNIT COST	SUBTOTAL COST	TOTAL COST	BASIS OR COMMENTS	SOURCE
Maintenance							
Replace Topsoil	Cubic Yard	81	\$15	\$1,215		6" of 1/10 of capped area	
Revegetate	MSF	4.4	18.25	\$80		1/10 of capped area	
Inspection	Lump Sum	1	\$6,000	\$6,000			
					\$7,295		
In Situ Volatilization	Year	1	\$50,000	\$50,000		Incl. electric, monitoring & labor	
					\$50,000		
Groundwater Monitoring							
Labor	Hours	40	\$35.00	\$1,400		Semi-annual sampling of 6 wells Based on 2 sampling personnel	Engineering Estimate
Laboratory Analyses						Semi-annual sampling of 6 wells	
-CLP VOA	Analyses	6	\$375.00	\$4,500			Basic Ordering Agreement
-CLP SVOA	Analyses	6	\$585.00	\$7,020			Basic Ordering Agreement
-CLP Metals	Analyses	6	\$339.00	\$4,068			Basic Ordering Agreement
Miscellaneous Expenses	Sample Event	1	\$2,000.00	\$4,000		Incl. travel, lodging, supplies	Engineering estimate
Reporting	Report	1	\$1,500.00	\$3,000		1 report per sampling event	Previous estimates
					\$23,988		
Total Capital Costs					\$709,560		
Total Annual O & M Costs					\$81,283	For Years 1 - 5	
Total Annual O & M Costs					\$31,283	For Years 6 - 30	
Approximate Present Worth Value					\$1,400,000		

TABLE C-10

DETAIL COSTING EVALUATION

SOIL REMEDIAL ACTION ALTERNATIVE No. 7

ON-SITE TREATMENT AND OFF-SITE DISPOSAL

(In Situ Treatment for AOC 1; Off-Site Disposal for Remaining AOCs)

CAPITAL COST ESTIMATE

20-Aug-93

COST COMPONENT	UNIT	QUANTITY	UNIT COST	SUBTOTAL COST	TOTAL COST	BASIS OR COMMENTS	SOURCE
Site Preparation							
Equipment Mobilization	Lump Sum	1	\$15,000	\$15,000		Excavation and treatment equipmen All AOCs: 140,000 SF Utilities hook up, site preparation	Previous estimates
Site Clearing	Acre	3.2	\$1,000	\$3,200			
Miscellaneous	Lump Sum	1	\$10,000	\$10,000	\$28,200		Previous estimates
In Situ Volatilization							
Treatment System	Cubic Yard	16500	\$20	\$330,000		For AOC 1 only; 4 feet depth Identify edge of contaminated area	Testa, 1991
Confirmation Sampling	Per Sample	165	\$450	\$74,250	\$404,250		Previous estimates
Off-Site Landfill							
Excavation and Loading	Cubic Yard	2500	\$20.00	\$50,000		AOCs 2 through 6 1 sample/100 cy excavated soil Based on 25 cy/truck Landfill in Pinewood, SC	Previous estimates
Confirmation Sampling	Per Sample	25	\$450	\$11,250			
Transportation (200 miles one way)	Loaded Mile	20000	\$3	\$60,000			
Disposal Fee (Nonhazardous)	Ton	3645	\$110	\$400,950	\$522,200		Previous estimates Means, 1993, p. 26 Vendor Quote
Site Restoration							
Fill and Compact	Cubic Yard	2500	\$5.00	\$12,500		Excavated areas Excavated areas All disturbed (cleared) areas General site cleanup	Engineering estimate
Grading	Square Yard	3400	\$0.45	\$1,530			
Revegetation	MSF	140	\$18.25	\$2,555			
Miscellaneous	Lump Sum	1	\$5,000	\$5,000	\$21,585		NAVFAC CES Means, 1993, p. 106 Engineering estimate
Demobilization							
Administrative Activities	Lump Sum	1	\$5,000	\$5,000		Reporting, etc.	Previous estimates
Equipment	Lump Sum	1	\$2,000	\$2,000	\$7,000		Engineering estimate
Subtotal Capital Cost					\$983,235		
Engineering @ 10%				\$98,324			
Contingencies @ 20%				\$196,647			
Pilot Studies @ 5%				\$49,162			
Total Capital Cost					\$1,327,367		

TABLE C-10 (continued)

DETAIL COSTING EVALUATION

SOIL REMEDIAL ACTION ALTERNATIVE No. 7

ON-SITE TREATMENT AND OFF-SITE DISPOSAL

(In Situ Treatment for AOC 1; Off-Site Disposal for Remaining AOCs)

O & M COST ESTIMATE

20-Aug-93

COST COMPONENT	UNIT	QUANTITY	UNIT COST	SUBTOTAL COST	TOTAL COST	BASIS OR COMMENTS	SOURCE
In Situ Volatilization - 5 Year	Year	1	\$50,000	\$50,000	\$50,000	Incl. electric, monitoring, and labor Includes sampling	
Total Capital Costs					\$1,327,367		
Total Annual O & M Costs					\$50,000.00	For Years 1 - 5	
Approximate Present Worth Value					\$1,500,000		