

Operation and Maintenance Manual MCB Camp Lejeune Groundwater Treatment System

Volume III of VII

Submitted to:

DEPARTMENT OF THE NAVY
Contract No. N62470-93-D-3032

Submitted by:



**OHM Remediation
Services Corp.**
A Subsidiary of OHM Corporation

5335 Triangle Parkway, Suite 450
Norcross, GA 30092

OHM Project No. 16032

November 1996

TABLE OF CONTENTS

Volume I

| | | |
|---------|--|------|
| 1.0 | SYSTEM OPERATIONS | 1-1 |
| 1.1 | General Process Description | 1-1 |
| 1.1.1 | Shallow Groundwater Influent Flow and Iron Removal System | 1-1 |
| 1.1.2 | Deep Groundwater Influent Flow | 1-1 |
| 1.1.3 | Air Stripping | 1-10 |
| 1.1.4 | Cartridge Filtration and GAC Adsorption | 1-10 |
| 1.1.5 | Treated Effluent Storage and Discharge | 1-10 |
| 1.2 | Operating Restart | 1-10 |
| 1.2.1 | Pre-Startup Checklist | 1-10 |
| 1.2.2 | Security and Site Access | 1-10 |
| 1.2.3 | Health and Safety | 1-12 |
| 1.2.4 | Key Contacts and Site Personnel | 1-12 |
| 1.2.5 | Equipment Labels | 1-26 |
| 1.2.6 | Baseline Readings | 1-26 |
| 1.3 | Groundwater Treatment System Startup | 1-27 |
| 1.3.1 | Introduction and Purpose | 1-27 |
| 1.3.2 | General Startup Sequence | 1-27 |
| 1.3.3 | Initial Startup | 1-29 |
| 1.3.3.1 | Motor Rotation | 1-29 |
| 1.3.3.2 | Turn On Pump Seal Water | 1-29 |
| 1.3.3.3 | To Initiate Shallow Aquifer Influent Flow | 1-30 |
| 1.3.3.4 | Initiate Metals Precipitation | 1-30 |
| 1.3.3.5 | Initiate Deep Aquifer Influent Flow | 1-31 |
| 1.3.3.6 | Flow Equalization in Groundwater Storage Tank | 1-32 |
| 1.3.3.7 | Air Stripper, Cartridge Filter, and Carbon Absorber Feed Preparation | 1-32 |
| 1.3.3.8 | To Begin the Flow from T-110 to Air Stripper, Cartridge Filters and Carbon Adsorbers | 1-33 |
| 1.3.4 | Normal Shut Down | 1-34 |
| 1.3.4.1 | Normal Shut Down - Case 1 (Maintain Tanks Half-full) | 1-34 |
| 1.3.4.2 | Normal Shut Down - Case 2 (Maintain Tanks Full) | 1-35 |
| 1.3.4.3 | Normal Shut Down - Case 3 (Maintain Tanks at Low Level) | 1-36 |
| 1.3.5 | Post Shutdown Procedures | 1-37 |
| 1.3.6 | Miscellaneous Equipment Startup and Shut Down | 1-37 |
| 1.3.6.1 | Startup and Shut Down of Sludge Pump to T-140 | 1-37 |
| 1.3.6.2 | Startup and Shut Down of Filter Press (X-140) | 1-38 |
| 1.3.6.3 | Sludge Recycle | 1-39 |
| 1.3.6.4 | Backwash GAC Carbon Adsorber | 1-40 |
| 1.3.6.5 | Backwash Water to X-130 | 1-41 |
| 1.3.6.6 | Transfer Water from Sump T-025 | 1-42 |
| 1.3.6.7 | Transfer Water from Sump T-115 | 1-42 |
| 1.4 | Normal Operations and Controls | 1-43 |
| 1.4.1 | Normal Operations | 1-43 |
| 1.4.2 | Instrumentation and Control System | 1-44 |

TABLE OF CONTENTS - CONTINUED

| | | |
|---------|--|------|
| 1.4.3 | Groundwater Extraction System | 1-45 |
| 1.4.3.1 | Shallow Groundwater Extraction System (Dwg P-3) .. | 1-50 |
| 1.4.3.2 | Deep Aquifer Extraction System | 1-52 |
| 1.4.4 | Iron Removal System | 1-53 |
| 1.4.4.1 | Mix Tank | 1-53 |
| 1.4.4.2 | Clarifier | 1-55 |
| 1.4.4.3 | Sludge Thickener | 1-56 |
| 1.4.4.4 | Sludge Dewatering Press | 1-56 |
| 1.4.4.5 | Head Tank | 1-56 |
| 1.4.4.6 | Chemical Storage | 1-57 |
| 1.4.5 | Groundwater Storage and Feed System | 1-58 |
| 1.4.5.1 | Groundwater Storage Tank and Feed System | 1-58 |
| 1.4.5.2 | Groundwater Storage and Feed System Instrumentation and Control | 1-58 |
| 1.4.5.3 | Chemical Storage | 1-60 |
| 1.4.6 | Air Stripping System | 1-60 |
| 1.4.6.1 | Air Stripper Column and Equipment | 1-60 |
| 1.4.6.2 | Air Stripper System Instrumentation and Control | 1-61 |
| 1.4.7 | Liquid Granular Activated Carbon (GAC) Adsorber System . | 1-62 |
| 1.4.7.1 | Cartridge Filters | 1-62 |
| 1.4.7.2 | GAC Adsorbers | 1-63 |
| 1.4.8 | Effluent Storage and Discharge System | 1-63 |
| 1.4.8.1 | Effluent Storage Tank and Discharge Equipment | 1-63 |
| 1.4.8.2 | Effluent Storage Tank and Discharge Instrumentation and Control | 1-64 |
| 1.4.9 | Secondary and Utility Systems | 1-65 |
| 1.4.9.1 | Backwash Water Holding Tank | 1-65 |
| 1.4.9.2 | Compressed Air System | 1-66 |
| 1.4.9.3 | Building Drainage System and Containment Sump ... | 1-66 |
| 1.4.9.4 | Sanitary Pump Station | 1-67 |
| 1.5 | Emergency Operations | 1-67 |
| 1.5.1 | Equipment Malfunction | 1-67 |
| 1.5.1.1 | Pump Failure | 1-67 |
| 1.5.1.2 | Air Stripper Blower Failure | 1-68 |
| 1.5.1.3 | Water Tank Failure | 1-68 |
| 1.5.1.4 | GAC Carbon Filter Malfunction | 1-68 |
| 1.5.1.5 | Cartridge Filter Malfunction | 1-69 |
| 1.5.1.6 | Automatic Flow Control Valve Malfunction | 1-69 |
| 1.5.1.7 | Caustic Tank Failure | 1-69 |
| 1.5.1.8 | Acid Tank Failure | 1-70 |
| 1.5.1.9 | Air Compressor Failure | 1-70 |
| 1.5.2 | Emergency Shutdown Procedures | 1-70 |
| 1.5.3 | Guidance on Emergency Operations of Utility Systems | 1-70 |
| 1.5.3.1 | Power Failure | 1-70 |
| 1.5.3.2 | Potable Water Failure | 1-71 |
| 1.5.3.3 | Natural Gas Failure | 1-71 |
| 1.5.3.4 | Compressed Air Failure | 1-71 |
| 1.6 | Critical Alarms and Autodialer | 1-72 |

TABLE OF CONTENTS - CONTINUED

| | | |
|-----|---|------|
| 2.0 | MAINTENANCE AND TROUBLESHOOTING | 2-1 |
| 2.1 | Introduction | 2-1 |
| 2.2 | Operator Service Requirements | 2-1 |
| 2.3 | Troubleshooting | 2-1 |
| 2.4 | Environmental Conditions | 2-5 |
| 2.5 | Preventive Maintenance | 2-5 |
| 2.6 | Corrective Maintenance | 2-5 |
| 2.7 | Troubleshooting Guides and Diagnostic Techniques | 2-13 |
| 2.8 | Wiring Diagrams and Control Diagrams | 2-13 |
| 3.0 | SAFETY PRECAUTIONS AND STANDARD OPERATING PROCEDURES | 3-1 |
| 3.1 | Introduction | 3-1 |
| 3.2 | Material Safety Data Sheets | 3-1 |
| 3.3 | Health and Safety Standard Operating Procedures | 3-1 |
| 4.0 | PERFORMANCE SAMPLING AND MONITORING | 4-1 |
| 4.1 | Introduction | 4-1 |
| 4.2 | Sampling Procedures | 4-4 |
| 4.3 | Quality Assurance/Quality Control (QA/QC) Samples | 4-5 |

TABLES

| | |
|-------------|--|
| Table 1.1 | Major Equipment List |
| Table 1.2.1 | Pre-Startup Check List |
| Table 1.2.2 | Key Contact List |
| Table 1.2.3 | Vendor Contact List |
| Table 1.2.4 | Instrumentation List |
| Table 1.2.5 | Process Valve List |
| Table 1.4.1 | Expected Flow from Each Well |
| Table 1.4.2 | Groundwater Treatment System Influent and Effluent Characteristics |
| Table 1.4.3 | Interlock Table |
| Table 2.1 | Weekly Lubrication and Maintenance Check List |
| Table 2.2 | Monthly Lubrication and Maintenance Check List |
| Table 2.3 | 6-month or Greater Lubrication and Maintenance Check List |
| Table 2.4 | Daily Check List |
| Table 2.5 | Weekly Check List |
| Table 2.6 | System Down Report |
| Table 2.7 | Maintenance and Repairs Report |
| Table 1.6.1 | Critical Alarms for Groundwater Treatment Plan |
| Table 4.1 | Effluent Treatment Criteria and Remediation Goals |
| Table 4.2 | Performance Sampling Summary |
| Table 4.3 | Laboratory Reporting Limits |
| Table 4.4 | Monitoring Wells |

TABLE OF CONTENTS - CONTINUED

APPENDICES

Appendix A Volume II:

- I Table of Contents
- II Major Equipment List and Contact List
- III Equipment Manuals
 - A. Air Stripper (C-200), Stripper Blower (D-200)
 - B. Cartridge Filters (F-220 A/B/C)
 - C. Carbon Filters (X-220 A/B)
 - D. Lamella Clarifier (X-131)

Appendix B Volume III:

- I Table of Contents
- II Major Equipment List and Contact List
- III Equipment Manuals
 - E. Plate Filter Press (X-140)
 - F. Refrigerated Compressed Air Dryer (X-150C)
 - G. Air Compressor (X-150 A/B)
 - H. Pumps-
 - Air stripper feed pump (P-110 A,B), Section 1
 - Sump pump (P-025 & P-025A), Section 2
 - Containment area sump pump (P-115), Section 2
 - Jet mixing pump & system (P-120), Section 3
 - Caustic feed pump (P-121), Section 4
 - Sludge blowdown pump (P-143), Section 5
 - Supernatant transfer pump (P-145), Section 1
 - Spent backwash water pump (P-205), Section 6
 - Acid feed pumps (P-211, P-212), Section 4
 - Well pumps (P-100, P-102, P-104, P-300, P-302, P-304, P-101, P-103, P-105, P-301), Section 7
 - Backwash water pump (P-241), Section 1
 - Reuse water pump (P-245), Section 6
 - GAC adsorber feed pumps (P-220 A/B), Section 1
 - Filter press feed pump (P-141), see section on Filter Press
 - Metal scavenger/coagulant pump (X-132A), to be purchased

Appendix C Volume IV:

- I Table of Contents
- II Major Equipment List and Contact List
- III Equipment Manuals
 - I Tanks-
 - Groundwater storage tank (T-110), Section 1
 - Caustic storage tank (T-121), Section 2
 - Sludge thickening tank (T-140), Section 3
 - Head tank (T-145), Section 4
 - Backwash water holding tank (T-205), Section 5
 - Acid storage tank (T-211), Section 6
 - Stripper effluent holding tank (T-220), refer to section on air stripper
 - Treated effluent holding tank (T-240), Section 5
 - Mix tank (X-130) & air diffusers, Section 7
 - J. Liquid Polymer Feed System (X-132)

TABLE OF CONTENTS - CONTINUED

- K. Mixer (A-130)
- L. Control and Computer System
- M. Control Instrumentations
- N. Control Cabinet/Panel & Wiring Diagrams
- O. Metering manhole, Parshall Flume & Ultrasonic Flow Meter

Appendix D Volume V:

- I Table of Contents
- II Major Equipment List and Contact List
- III Equipment Manuals - Miscellaneous and building equipment
 - P. Transformer
 - Q. Well Houses
 - R. Roll Up Doors
 - S. Room Air Conditioning Unit
 - T. Bathroom Fixtures
 - U. Water Heater
 - V. Roof Fans and Exhaust Fans
 - W. Building Gas Heaters
 - X. Ventilation Louvers
 - Y. Roof Insulation
 - Z. Autodialer
 - AA. Miscellaneous Electrical Equipment

Appendix E Volume VI:

- I Table of Contents
- II Programmable Logic Controller (PLC) System and Instrumentation
 - A. List of Contractor/Subcontractors/Manufacturers/Suppliers
 - B. Operation and Maintenance Manual for Programmable Logic Controller (PLC) System
 - C. Logic Tables
 - D. Series 90-70 Programmable Controller Reference Manual
 - E. Logicmaster 90, Series 90-30/20 Micro Programming Software User's Manual

Appendix F Volume VII:

- I Table of Contents
- II Programmable Logic Controller (PLC) System and Instrumentation
 - F. Cimplicity MMI for Windows NT, Cimplicity MMI for Windows 95, Cimplicity Server for Windows NT, Device Communication Manual
 - G. TCP/IP Ethernet Communications for the Series 90-70 PLC User's Manual
 - H. Operation and Maintenance Manual for PC Workstation
 - I. Operation and Maintenance Manual for Instrumentation
 - J. SM 3000 Smart Meter User's Manual (34-ST-25-08C 05/95)
 - K. ST 3000 Smart Transmitter Series 100E and Series 900 and SFC Smart Field Communicator Model STS 103 Installation Guide (34-ST-33-31A 08/95)

TABLE OF CONTENTS - CONTINUED

- L. Instruction Manual for Model 1181PH/ORP Two-Wire Transmitters (P/N 5101181PH November 1995)
- M. Installation and Operating Instructions for Drexelbrook Series 508-45, -46, -47, -49 Universal II Level Transmitters using 408-8200 Series Cote-Shield Electronics (EDO#5-95-250 408-8200-LM)
- N. Signet 8510 Compak Flow Transmitter Instructions
- O. Installation and Operating Instructions for Model L-6 Float Switch (Bulletin E-20)
- P. Approved Submittal Data on Motor Controllers, Dry Type Transformers, Panelboards, Well Pump Panel and Fixtures
- Q. List of Qualified Permanent Servicing Organizations for Support of the Programmable Logic Controller (PLC) System and Instrumentation Equipment

TABLE 1.1

| <p align="center">MAJOR EQUIPMENT LIST MCB Camp Lejeune - Groundwater Treatment System OHM Project #16032</p> | | | |
|--|---|------------|-----------------------------------|
| Item ID# | Component | Item ID# | Component |
| C - 200 | Air stripping column | T - 220 | Stripper effluent holding tank |
| F - 220A/B/C | Cartridge filter | T - 240 | Treated effluent holding tank |
| K - 200 | Air stripper column fan | X - 130 | Mix Tank |
| P - 025 | Building drainage pump (wet well) | A - 130 | Mixer |
| P - 025A | Building drainage pump (wet well) | X - 131 | Inclined plate clarifier |
| P - 110A | Air stripper feed pump | X - 132 | Liquid polymer feed system |
| P - 110B | Air stripper feed pump (back-up) | X - 132A | Metal scavenger/Coagulant pump |
| P - 115 | Containment area sump pump | X - 140 | Plate and frame filter press |
| P - 120 | Jet mixing pump | X - 150A/B | Air compressors |
| P - 121 | 50% NaOH feed pump | X - 150C | Refrigerated air dryer |
| P - 141 | Filter press feed pump | X - 150D | Compressed air receiver |
| P - 143 | Sludge blowdown pump | X - 150F | Compressed air oil separator |
| P - 145 | Supernatant transfer pump | X - 150G | Compressed air particulate filter |
| P - 205 | Spent backwash water pump | X - 220A | GAC adsorber |
| P - 211 | 93% H ₂ SO ₄ feed pump | X - 220B | GAC adsorber |
| P - 212 | 93% H ₂ SO ₄ feed pump | P - 100 | SRW-1 shallow well pump |
| P - 241 | Backwash water pump | P - 102 | SRW-2 shallow well pump |
| P - 245 | Reuse water pump | P - 104 | SRW-3 shallow well pump |
| P - 220A | GAC adsorber feed pump | P - 300 | SRW-4 shallow well pump |
| P - 220B | GAC adsorber feed pump (back-up) | P - 302 | SRW-5 shallow well pump |
| T - 025 | Building drainage wet well | P - 304 | SRW-6 shallow well pump |
| T - 110 | Groundwater storage tank | P - 101 | DRW-1 deep well pump |
| T - 121 | 50% NaOH storage tank | P - 103 | DRW-2 deep well pump |
| T - 140 | Sludge thickening tank | P - 105 | DRW-3 deep well pump |
| T - 145 | Head tank | P - 301 | DMW-1 monitoring well pump |
| T - 205 | Backwash water holding tank | | |
| T - 211 | 93% H ₂ SO ₄ storage tank | | |

TABLE 1.2.2

| KEY CONTACT LIST MCB Camp Lejeune - Groundwater Treatment System OHM Project #16032 | | | |
|--|-------------------|----------------------------|--------------|
| Company/Agency | Contact | Title | Phone Number |
| OHM Site | | | 910-451-2390 |
| OHM Personnel | Jim Dunn | Project Manager | 770-734-8072 |
| | Alan Whitt | Project Supervisor | 910-451-2599 |
| | Randy Smith | Project Supervisor | 910-451-2599 |
| | Dwayne Currie | Deputy Program Manager | 770-453-7707 |
| | Phil Verbout | Sr. Electrical Engineer | 713-775-7631 |
| | Steve Grant | Site H & S Officer | 910-451-2390 |
| | Terry Whitt | Sr. Project Chemist | 770-453-7686 |
| | Greg Gilles | Technical Manager | 770-453-7687 |
| | Kai Mak | Sr. Project Engineer | 770-453-7607 |
| | Tom McCrory | Sr. Project Hydrogeologist | 770-453-7663 |
| | Angelo Liberatore | Reg. H & S Manager | 770-453-7671 |
| Stone & Webster | Chuck Lawrence | QC Engineer | 615-755-9753 |
| MCB Camp | Vann Marshburn | Supervising Engineer | 910-451-2583 |
| | Lt. Cheryl Hansen | A-ROICC | 910-451-2581 |
| | John Cotton | Construction Inspector | 910-451-5006 |
| LANTDIV | Kate Landman | RPM | 804-322-4811 |
| | Jerry Haste | COTR | 804-444-8422 |
| IRD/EMD | Neal Paul | | 910-451-5068 |
| | Tom Morris | | 910-451-5068 |
| NC DEHNR | Patrick Watters | Superfund RPM | 910-353-3558 |
| EPA-Region IV | Gena Townsend | RPM | 404-347-3066 |
| Southerland Electric | Scott Sosa | Project Manager | 910-347-1754 |
| Hatcher Construct. | Donald Hatcher | Owner/PM | 910-285-7633 |
| N.E. Construction | Tom DeLong | Project Manager | 910-733-2801 |

TABLE 1.2.3

| VENDOR CONTACT LIST MCB Camp Lejeune - Groundwater Treatment System OHM Project #16032 | | | |
|---|---------------------------------|------------------|---------------------------|
| Company | Equipment | Contact | Phone/Fax Number |
| Industrial Sales | Valves, gauges, fittings, pumps | Gene Wells | 910-763-5126 910-763-3207 |
| P.R. Bradley & Assoc. | Meter pumps, Lighting mixer | Mike Wolfe | 770-998-1956 770-998-0119 |
| Drillers Services Inc. | Wells, well pumps | Terry Yount | 800-334-2308 704-322-7674 |
| Industrial Plastics | Plastic pipe & fittings | Steve Bailey | 770-844-7324 912-748-8327 |
| Carolina Plastic Supply | HDPE pipe & fittings | Marc Davis | 704-588-0541 704-588-5742 |
| Goulds Pumps Inc.. | Pumps | Joe Ruggiero | 770-446-3369 770-446-3651 |
| Boart Longyear | Downwell tubing | Bob Beyer | 770-469-2720 770-498-2841 |
| Palmer Manufacturing | FRP Tanks (T-110) | Scott Case | 770-925-4855 770-925-4869 |
| Northeast Construction | Buildings | Steve Straper | 910-353-3558 910-353-3005 |
| Proco Products | | Sylvia Augusto | 800-344-3246 209-943-0242 |
| Atlanta Rod | Nuts/ bolts | Mary White | 770-889-2136 706-356-2940 |
| Hilti Corp. | Nuts/bolts, fastners | David Holloway | 800-879-8000 800-879-7000 |
| Eco Equip. Inc. | Jet mixer pump system | Steve Hart | 770-345-2118 770-345-2699 |
| Hertz Equipment | | Steve Koroly | 910-799-9751 910-395-2405 |
| Fowler Manf. | Platforms | Doug Wolcott | 904-246-4886 904-241-8056 |
| Chet Adams | Elec. & Gas Heaters | E. Adams | 919-851-6331 919-851-6371 |
| Ingersall Rand | Air compressors | Gary Michael | 770-936-6200 770-936-8210 |
| R&W Construction | Tanks, structure steel | Wayne Pierce | 910-455-1830 910-455-9163 |
| Ladder Distr. Inc. | | Carl Jacobsen | 770-447-9057 770-447-9057 |
| Cowen Supply | Piping hardware | Greg Southwell | 404-351-6351 404-351-1259 |
| C.M. Kemp Manf. | Dri-breather | Venita Gornew | 410-761-5100 410-766-9105 |
| Envirotrol | Carbon filter system | Tim Sokol | 412-741-2030 412-741-2670 |
| Pumping Systems Inc. | Diaphragm Air pumps | Michael Konopa | 770-458-9555 770-455-9133 |
| Filtration Tech. | Cartridge/Air filters | Scott Matthews | 919-859-0124 919-859-0370 |
| Gray Bar Elect. | Electric material supplies | Doyle Strickland | 770-441-5580 770-446-7693 |

TABLE 1.2.3 (Cont.)

| VENDOR CONTACT LIST MCB Camp Lejeune - Groundwater Treatment System OHM Project #16032 | | | |
|---|-------------------------------|------------------|---------------------------|
| Company | Equipment | Contact | Phone/Fax Number |
| Dewy Brothers | Manhole rings & covers | Pat Miller | 800-931-9391 |
| Hercules Steel | Inffluent box | Claude Scott | 910-488-5110 910-488-4040 |
| National Environ. Systems | Air Stripper tower | Pixie Terreault | 508-761-6611 508-761-6898 |
| Saws controls | Ceramic Air diffusers | Larry Sears | 770-993-4392 770-998-2430 |
| Delta Sales | Eyewash stations | Gene Waters | 770-934-9960 770-934-6865 |
| Hugo Jahnz & Assoc. | Plastic tanks | Ansley Jimmerson | 770-889-1732 770-887-7405 |
| Engineered Fiberglass | FRP Well Building | Clarence Kazmir | 770-475-2242 770-664-6906 |
| Jenkins Gas & Oil | LP tank | Keith McGouden | 910-455-1711 910-346-9404 |
| George Selke Co. | HDPE tanks | Mike Callahan | 770-925-4855 770-925-4869 |
| Hoffman & Hoffman | Roof fans | Bill Poole | 919-781-8011 919-787-6019 |
| Tracon Inc. | Meter manhole | | 770-475-2242 770-664-6906 |
| Parkson Corp. | Lamella separator | Larry Sears | 770-993-4392 770-998-2430 |
| Tindall Concrete | Concrete Manholes | Fred Bosket | 864-576-3230 864-587-8828 |
| J.L. Pierce Surveying | Surveyor | J. Pierce | |
| Semblex Inc. | Polymer feed system | Steve Hart | 770-345-2118 770-345-2699 |
| Netzsch Filter | Filter press | Robert N. Hanks | 610-363-8010 610-363-0971 |
| High Rise Service Co. Inc. | Acid containment area coating | Donnie Cannon | 910-371-2325 |
| ISCO Inc. | Ultrasonic Effluent Flowmeter | | 800-228-4373 |
| Lightnin c/o Bradley & Assoc. | Mixer (A-130) | Mike Wolfe | 404-998-1956 |
| Tencarva Machinery Co. | Service all Goulds Pumps | Scott Hudson | 910-799-8800 910-799-8801 |
| Utility Precast Inc. | Electric manholes | Tommy McClellan | 704-596-6283 704-596-6289 |

| Table 1.2.3 (Cont.) | | | |
|----------------------------------|-------------------------------------|----------------|---------------------------|
| US Foundry & Manufacturing Corp. | Electrical manhole rings & cover | Steve Douglass | 404-696-8810 404-696-9482 |
| Worth Chemical Corp. | 50% Caustic | Stan Tew | 864-574-2785 |
| KOCH Sulfur Products Co. | 93% Sulfuric acid | Ray Wilson | 800-414-2243 |
| Betz Entec, Inc. | Polymer, metal scavenger chemicals | Barry Owings | 919-783-7071 919-783-7093 |
| Halliday Prods. | Alum access frame | Jim Cook | 407-298-4470 407-298-4534 |
| G.E. Supply | Transformer & Elec. Equip. Supplies | Dave Whinsile | 404-840-4196 |
| Bertsch Co. | Pipe fittings | Bunnie | 419-666-6605 419-666-3344 |

Netzsch Filtration System

OPERATION & MAINTENANCE MANUAL

for

Dewatering Press
X-140

Soil And Groundwater Remediation-OU No. 2

M.C.B. Camp Lejeune

OHM Remediation Services

Netzsch Incorporated

Job No.: 401-880/95

Serial No.: 400-980

Filter Press Model: 630mm x 630mm

TABLE OF CONTENTS

WARRANTY

SAFETY CONSIDERATIONS

SECTION I: GENERAL INFORMATION

- Chapter I Filter Press Dewatering Theory**
- Chapter II Filter Press Construction Description**
- Chapter III Description of Equipment Supplied**
- Chapter IV Prerequisites Before Start-Up**

SECTION II: INSTALLATION, EQUIPMENT DESCRIPTION, START-UP

- Chapter V Filter Press Installation**
- Chapter VI Description of the Air Driven Hydraulic Closure System**
- Chapter VII Start-Up of the Air Driven Hydraulic Closure System**
- Chapter VIII Description of Filter Plates and Cloths**

SECTION III: TROUBLESHOOTING AND MAINTENANCE

- Chapter IX Process Troubleshooting**
- Chapter X Filter Press Troubleshooting**
- Chapter XI General Maintenance**

SECTION IV: OPERATION DESCRIPTION

- Chapter XII Filtration Cycle**
- Chapter XIII Core Blow**
- Chapter XIV Sequence of Operations**

SECTION V: SPARE PARTS

SECTION VI: MANUFACTURER'S MANUALS

SECTION VII: DRAWINGS

SAFETY CONSIDERATIONS

The Netzsch Filter Press is a customized piece of equipment. It is essential for management and operating personnel to read and understand the contents and operation of the Filter Press to ensure optimum performance and maximum safety.

- Read the manual before installing, operating or maintaining the Filter Press.
- The operation of the Filter Press should be thoroughly demonstrated to the operating personnel.
- Do not operate or maintain the Filter Press unless all safety devices are enforced.
- Operating personnel should be trained in the use of the safety devices.
- Maintenance personnel should perform regular and preventive maintenance to ensure an optimal and continuous operation.
- Operating and maintenance personnel should be in compliance with all OSHA lockout or tagout system procedures.

The safety concerns mentioned in this manual are not intended to cover all of the hazards that may exist.

NETZSCH INCORPORATED
Filter Press Division
119 Pickering Way
Exton, PA 19341-1393
Phone: (610) 363-8010
Fax: (610) 363-0971

STANDARD LIMITED WARRANTY

NETZSCH INCORPORATED

FILTER PRESS DIVISION

The Seller will repair or replace, at its option, defects in material or workmanship developing within one (1) year from factory shipment, or agreed-upon date on original equipment purchase order, providing written notice of such defect is received and substantiated by the Seller.

With respect to the products not manufactured by the Seller, Seller will, if practical, pass along the warranty of the original manufacturer.

Correction of such defects by repair or replacement, F.O.B. Factory, shall constitute a fulfillment of the guarantee. The return of all parts submitted under this guarantee must be authorized by the Seller, and transportation pre-paid by the Buyer. The Seller has no liability for any repairs made outside the Seller's factory, unless with prior written consent.

The guarantee will not be applicable unless the apparatus has been properly cared for and operated under normal conditions; nor will the Seller be responsible for damage resulting from improper storage or handling prior to placing the apparatus in service.

The warranty does not extend to, and the Seller shall have no liability for:

1. Any incidental, special or consequential loss, cost, expense, liability or damage, whether direct or indirect.
2. Equipment conditions caused by fair wear and tear, abnormal conditions of use, accident, neglect or misuse of equipment.
3. Deviation from operating instructions, specifications or other terms of sale.
4. Labor charges, loss or damage resulting from improper operation, maintenance or repairs made by person(s) other than the Seller.
5. Improper application of product.
6. Any process performance guarantees such as but not limited to, filter cake solids, cycle times, production rates etc.

IN NO EVENT SHALL SELLER BE LIABLE FOR ANY CLAIMS, WHETHER ARISING FROM BREACH OF CONTRACT, OR WARRANTY OF CLAIMS OF NEGLIGENCE OR NEGLIGENT MANUFACTURE, IN EXCESS OF THE PURCHASE PRICE.

SECTION I: GENERAL INFORMATION

Chapter I Filter Press Dewatering Theory

Chapter II Filter Press Construction Description

Chapter III Description of Equipment Supplied

Chapter IV Prerequisites Before Start-up

Chapter I

FILTER PRESS DEWATERING THEORY

Pressure filtration is the separation of suspended solids from a liquid slurry using a positive pressure differential as the driving force.

The fixed or variable volume, recessed-plate filter press consists of a number of plates that are rigidly held in a frame to ensure alignment. These plates are pressed together either hydraulically or electro-mechanically between a fixed and moving end. The plates have a drainage surface connected to drainage ports for filtrate discharge. A large port for sludge feed is usually arranged in the center of the plates. A filter cloth covers the drainage surface of each filter plate to provide a filter medium. A closing device (usually a hydraulic cylinder) presses and holds the plates together during sludge feed. Slurry is pumped into the press through the inlet port with terminal pressures of 100 to 225 psig as the norm during the sludge feed cycle.

The filter medium captures the suspended solids and permits filtrate to drain through the plate channels. Solids collect in the chamber until a practical low feed rate is reached and the filter sludge feed cycle is terminated. At this time, the Filter Press feed pump is stopped, the pressure is relieved, the hydraulic cylinder is opened and the individual filter plates are shifted for cake discharge.

The filtration process may be described as combination constant rate and constant pressure feed process. The beginning of the cycle uses a constant filtration rate up to the maximum pumping head available. In the constant pressure phase, the head loss remains constant and thus, the filtration rate continuously declines due to the build-up of cake.

At the start of the slurry feed to the Filter Press, resistance to filtration remains relatively low and constant until enough solids collect on the filter cloth to cause the press chambers to fill. This phase of the feed cycle is characterized by high and constant feed rates and relatively low pressure. As the solids accumulate and the cake build-up begins, the resistance to filtration builds, the flow rate declines, and the pressure increases. Solids will accumulate at a steadily declining rate until the formed cake undergoes a significant

change in porosity that severely restricts the amount of flow discharged as filtrate. Due to the increased resistance to feed through the cake, pressure will continue to increase until the set point pressure or terminal pressure is reached.

Once the terminal pressure and reduced flow rate have been reached, the filtration cycle is complete. The feed system can be stopped and the Filter Press can be vented of all internal pressures. The Filter Press is now ready for cake discharge.

Chapter II

FILTER PRESS CONSTRUCTION DESCRIPTION

The Netzsch Filter Press consists mainly of the press frame (skeleton) and the filter plate set.

Framework

The press frame is a self-supporting construction with the following main components:

1. Head plate assembly
2. End plate assembly
3. Traverse assembly
4. Hydraulic closure system
5. Side rails

The **head plate assembly** is provided with connections for sludge inlet and filtrate discharge. All connections are connected and pressure sealed, by liner pipes with the plate set. This guarantees that the liquid does not come in contact with metal surfaces and thus provides maximum corrosive protection.

The **end plate** is supported and guided by the side rails. It is connected with the hydraulic ram (cylinder). The end plate is retracted manually by the filter press operator.

The **traverse assembly** supports the hydraulic ram (cylinder) and hydraulic closure system.

The **hydraulic closure** power unit is mounted as part of the traverse assembly. A pneumatically actuated hydraulic pump is provided to close and seal the filter plates and maintain the closure of the filter plates. The unit is designed to open and close the filter

press and automatically compensate for any thermal expansion or contraction of the filter plate pack.

The maximum hydraulic closing pressure of this closing device can be controlled by the air pressure regulator with gauge mounted inside the steel cabinet. The maximum hydraulic closing pressure is 5600 psi (385 bar).

Note: Depending on the application and choice of plates, it might not be necessary to use the available maximum closing pressure.

The **side rails** are designed to withstand the direct tension and to support the weight of the plate set and the filter cakes.

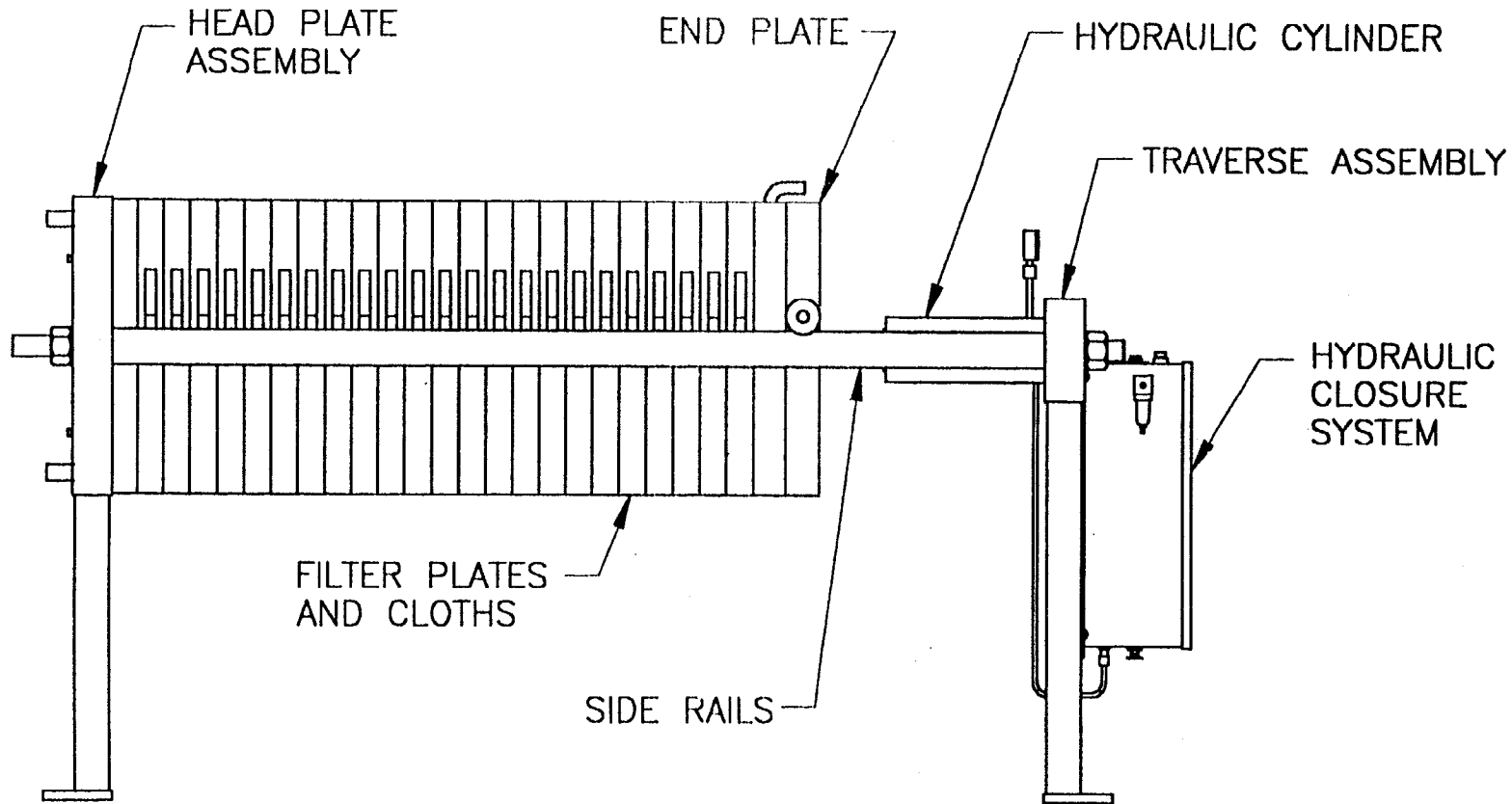

| | | | |
|----------------------------------|--------------|--------------------------|----------------|
| TITLE 630LP FILTER PRESS AIR/OIL | | | |
| DRAWN JC | DATE 6/14/95 | CHK'D <i>[Signature]</i> | DATE |
| SCALE .062=1 | | APP'D <i>[Signature]</i> | DATE 4/15/95 |
| SHEET NUMBER | of | SIZE | DRAWING NUMBER |
| | | A | 41175210 |
| ORDER/PROJECT NUMBER | | | SHT. REV. |

Netzsch 630LP Filter Press

NETZSCH 
Filtration Systems

Chapter III

DESCRIPTION OF EQUIPMENT SUPPLIED

Description of Equipment for your NETZSCH Filter Press

ORDER NO: 0401088095

SERIAL NO: 400-980

MODEL: 630/LP/I/18-24

SIZE OF PLATES: 630MM X 630MM

AMOUNT OF CHAMBERS: 18 EXPANDABLE TO 24

CAKE VOLUME: 6.0 FT³ TO 8.1 FT³

CAKE AREA: 90 FT² EXPANDBLE TO 156 FT²

CAKE THICKNESS: 32MM- 1.25 INCH

FILTRATE DISCHARGE: CLOSED

OPERATING PRESSURE: FEED UP TO 100 PSI

SKELETON: RIGID STRUCTURAL STEEL CONSTRUCTION

CLOSING DEVICE: AIR/HYDRAULIC CLOSURE

POWER CONSUMPTION: 80-100 PSI @ 5-10 CFM

MAXIMUM CLOSING PRESSURE: 385 BAR (5600 PSI)

ACCIDENT PREVENTION DEVICE: N/A

DISCHARGE TROUGH: N/A

DRIP TRAYS: N/A

CORE BLOW: MANUAL

FIILTRATE AIR BLOW: MANUAL

1 PLATE SET: CONSISTING OF 17 INTERMEDIATE PLATES;
1 HEAD PLATE, 1 END PLATE

1 CLOTH SET: CONSISTING 17 INTERMEDIATE CLOTHS,
1 HEAD CLOTH, 1 END CLOTH

Description of Equipment (CONTINUED)

FEED SYSTEM: ONE (1) AIR DIAPHRAM PUMP : WILDEN M-4

CONTROL SYSTEM: AIR OPERATED CONTROL SELECTOR SWITCH

ACCESSORIES: ONE (1) 60" SELF DUMPING CAKE HOPPER

SPARE PARTS: (1) COMPLETE SPARE FILTER CLOTHS
(1) DUMMY PLATE

Chapter IV

PREREQUISITES BEFORE START-UP

Before the equipment leaves the factory, it is thoroughly examined and pre-tested. However, it is necessary to check the following upon receipt of the equipment:

1. Please check immediately for any damage which might have occurred during transport. Complaints at a later date would not be acceptable to most insurance companies.
2. Please check immediately with shipping papers to be sure all items have been received. Later complaints cannot be accepted.
3. The Filter Press must be properly aligned and leveled. See Chapter V for further details.

SECTION II: INSTALLATION, EQUIPMENT DESCRIPTION, START-UP

Chapter V Filter Press Installation

Chapter VI Description of the Air Driven Hydraulic Closure System

Chapter VII Start-up with Air Driven Hydraulic Closure System

Chapter VIII Description of Filter Plates and Cloths

Chapter V

FILTER PRESS INSTALLATION

The Netzsch Filter Press is a customized piece of equipment. Special care must be applied during the installation of the Filter Press to ensure several years of trouble-free operation.

Lifting

The Filter Press must be removed from the shipping skid to its mounting foundation by utilizing lifting straps and a spreader bar if necessary. Smaller Filter Presses may be removed from the shipping skid with a forklift.

Note: Please use a qualified rigger and proper lifting equipment when lifting and moving the press.

Storage

If the Filter Press must be stored for a period of time, it should be stored in a level place and out of direct sunlight. The Filter Press should be completely covered utilizing an opaque tarp.

Foundation

The customer is responsible for preparing a level and square mounting foundation. Concrete foundations should have a suitable set time before installation.

Installation

The Filter Press must be closed and under hydraulic pressure. The press can be lifted and set down onto the mounting foundation. The Filter Press should be checked for level horizontally and vertically. The press should be level within $\pm 1/16''$. Next, the Filter Press must be checked for squareness. Square the press by utilizing the diagonal measurement method. Measurements can be taken on the side rails or at the mounting feet. The press should be square within $\pm 1/16''$.

Netzsch 630LP Filter Press
Installation (Continued)



The Filter Press can then be permanently secured to the foundation.

Note: All external piping to the Filter Press must be square and level to prevent slurry or air leaks during start-up.

UNLOAD

1. THE FILTER PRESS MUST BE CLOSED AND UNDER PRESSURE.
IF HYDRAULIC PRESSURE IS LESS THAN 200 bar (3000 psi) CONSULT NETZSCH INC.
2. WEB SLINGS SHOULD BE PLACED ONLY AT POINTS MARKED ON DRAWINGS.
3. SMALLER FILTER PRESSES MAY BE REMOVED FROM THE SHIPPING SKID WITH A FORK LIFT.

INSTALLING

1. THE FILTER PRESS MUST BE SQUARE AND LEVEL WITHIN $\pm 1/16"$ FOR PROPER OPERATION.
2. THE FILTER PRESS CAN THEN BE PERMANENTLY SECURED TO THE FOUNDATION. (CONSULT NETZSCH INC. IF MACHINE IS TO BE WELDED TO FOUNDATION)

STORAGE

1. THE FILTER PRESS SHOULD BE STORED TO THE ABOVE INSTRUCTIONS EXCEPT FOR PERMANENT MOUNTING.
2. THE FILTER PRESS MUST BE COMPLETELY COVERED DURING STORAGE.
3. SUNLIGHT WILL DETERIORATE THE FILTER CLOTHS AND FILTER PLATES IF EXPOSED FOR A LONG PERIOD OF TIME.

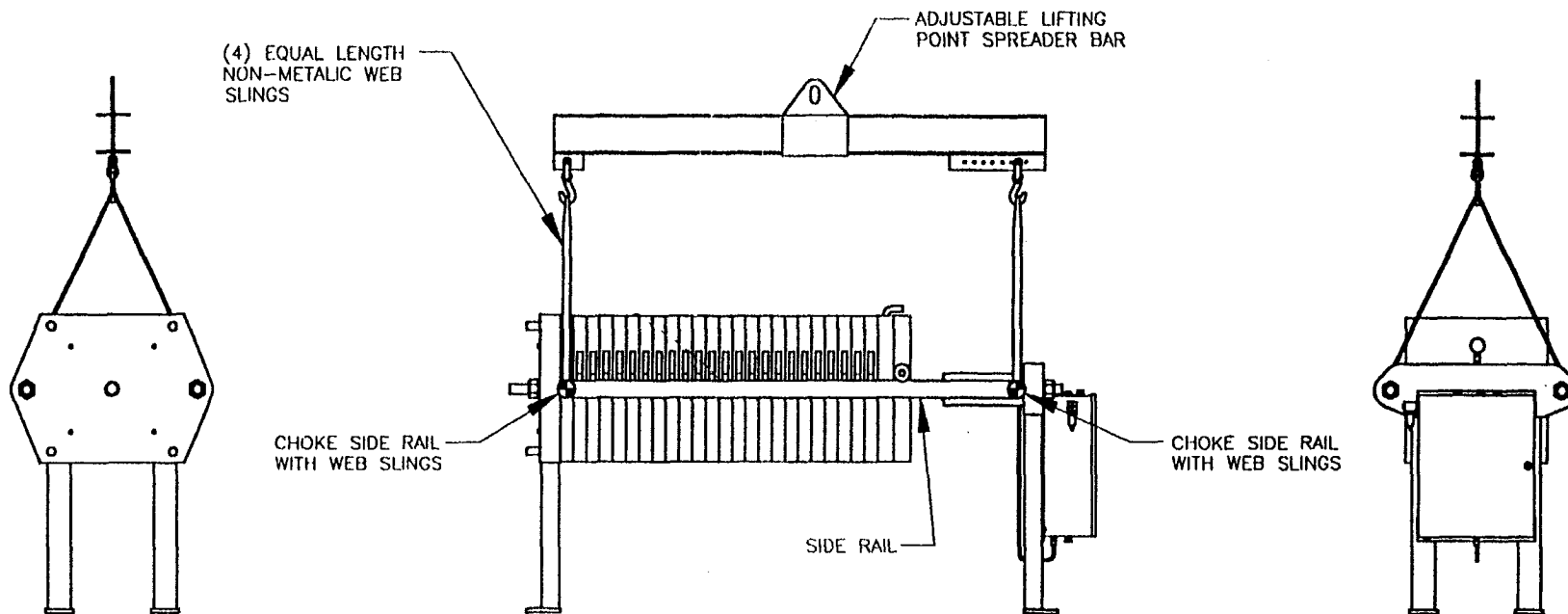

USE OF LIFTING STRAPS AND SPREADER BAR RECOMMENDED
SEE SUBMITAL DRAWING FOR ACTUAL FILTER PRESS WEIGHT AND DIMENSIONS



| | | | |
|---|----------------------|-------------------------|-------------------------|
| TITLE 630LP FILTER PRESS LIFTING POINTS | | | |
| DRAWN JC | DATE 6/14/95 | CHKD <i>[Signature]</i> | DATE |
| SCALE .031=1 | | APPD <i>[Signature]</i> | DATE 6.15.95 |
| SHEET NUMBER of | ORDER/PROJECT NUMBER | SIZE A | DRAWING NUMBER 41175610 |

SHT. REV.

Chapter VI

DESCRIPTION OF THE AIR DRIVEN HYDRAULIC CLOSURE SYSTEM

The 630LP Filter Press utilizes a pneumatic/hydraulic power unit located on the traverse assembly. The closure system consists mainly of the following:

- Single-acting hydraulic cylinder
- Air/Oil hydraulic power unit
- Hydraulic control

In order to maintain the closing hydraulic pressure during the Filter Press operation, the Netzsch air driven closing device is equipped with an air pressure regulator located in the power unit enclosure.

The Hydraulic Cylinder

The single-acting hydraulic cylinder is designed to close the plate set and seal it during the dewatering cycle. It also opens the plate set after the dewatering cycle is completed. The design operating hydraulic pressure is 5600 psi.

The Air/Oil Hydraulic Power Unit

The hydraulic power unit is an air/oil intensifier system. The customer supplied compressed air is the motive power. The reciprocating piston pump intensifies the hydraulic oil by the air to oil piston area ratios. Air pressure operating on the large piston produces a force. This force is transmitted to the smaller oil piston and produces a higher pressure.

The system has a flow crossover circuit. There is a high flow/low pressure circuit that will extend the hydraulic cylinder, then the low flow/high pressure circuit will build the necessary hydraulic pressure.

The system is also designed to automatically compensate for any thermal expansion or contraction of the filter plate pack.

Chapter VII

START-UP WITH AIR DRIVEN HYDRAULIC CLOSURE SYSTEM

A. Closing the Press

1. Before starting to close the press, make sure there are no particles on the surface of the filter cloths or between the plates.
2. Move the intermediate plates toward the head plate. Make sure the plates are brought back straight and aligned correctly.
3. Assuming that the in-line air is connected to the 0.25 NPT air connection, push the “extend” button to close the Filter Press. If at any time during this portion of the closing stroke the operator removes his hand from the button, the Filter Press will open (retract).

When the operator holds the switch until the Filter Press closes and the hydraulic pressure reaches a preset limit (500 psi), the hydraulic pump will continue to pump and maintain pressure on the system even if the switch is released.

The closing pressure is regulated by a pressure regulator in the steel cabinet. This pressure regulator controls the air pressure in the system; however, this pressure is not the actual hydraulic pressure being exerted in the Filter Press. Adjusting the air pressure regulator will adjust the hydraulic pressure. The air pressure should be adjusted until the hydraulic pressure reaches 385 bar (5600 psi).

B. Opening the Press

1. When the button is actuated to open (retract) the press, the spring return hydraulic cylinder will fully retract and open the press.

NOTE: If air pressure has been lost, the press will be locked hydraulically in position. The Filter Press at this time cannot be opened by pressing the “retract” push-button. When air pressure is applied, the power unit will bring the system pressure back up to the maximum pressure if it has fallen. Once air pressure is reapplied, pressing the “retract” push-button will open the Filter Press.

Chapter VIII

DESCRIPTION OF FILTER PLATES

The Filter Press is equipped with polypropylene constructed filter plates. Each intermediate filter plate is furnished with four (4) discharge ports and one (1) feed port or one (1) discharge spigot and one (1) feed port. All the plates shall be non-reinforced, molded, pressure-resistant polypropylene and equipped with handles for plateshifting.

The design feed pressure is 105 psig (max). Please see the pressure vs. temperature chart for non-ambient slurry temperature considerations.

Excessive Filter Press feed pressure or slurry temperature will violate the Filter Press warranty.

The filter plate sealing surface must be kept clean during the filtration process.

The filter plates should not be subject to thermal shock.

The Filter Press must be operated free from differential pressures.

(PSI)

(PSI)

———— = PP HOMOPOLYMERISAT

DWG 41175010

FILTERPLATE CALCULATED FOR 120 PSI

FILTERPLATE CALCULATED FOR 225 PSI

105

225

210

195

180

165

150

135

120

105

90

75

60

45

30

15

0

-10

0

+10

20

30

40

50

60

70

80

90

100

(°C)

(SLURRY TEMPERATURE)

32

50

60

86

104

122

140

158

176

194

212

(°F)

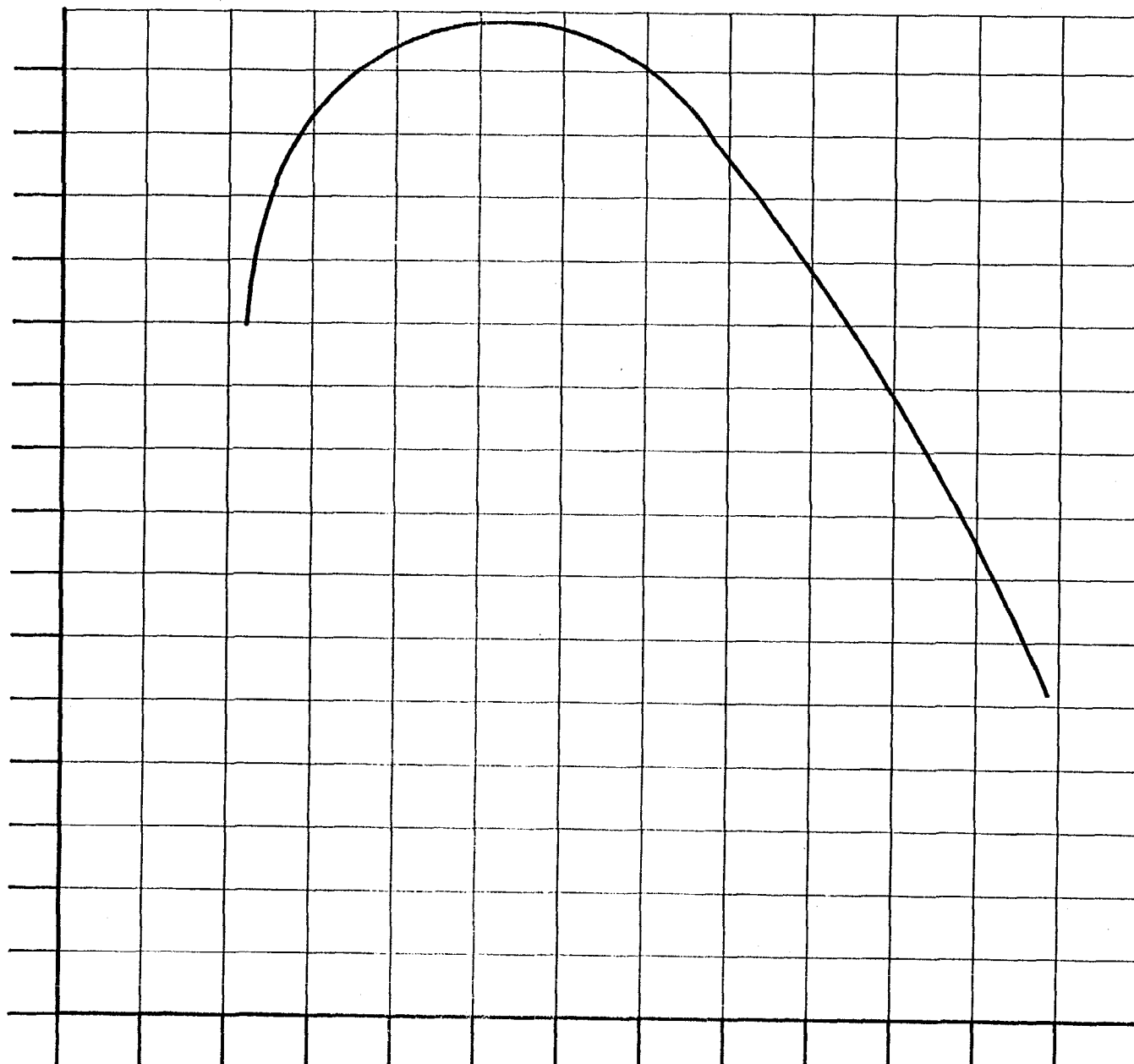

DESCRIPTION OF FILTER CLOTHS

The Filter Press is equipped with a filter media, namely called a filter cloth. Each Filter Press has one head and end single cloth. Each chamber plate is equipped with a barrel-neck filter cloth.

The filter cloth media is determined by the slurry application based upon the following characteristics:

1. Filtration efficiency
2. Good cake discharge
3. Low blinding
4. Mechanical resistance
5. Chemical resistance

In order to put a set of filter cloths on the filter plates, whether it be a new press or simply changing the filter cloths, the following steps should be followed. The design of the cloths used by Netzsch allows the mounting of the cloths without removing the filter plates from the press. The procedure is simple and takes little time to accomplish:

1. By laying on a flat surface, fold one section of cloth diagonally to create a diaper shape.
2. Fold edges so they overlap.
3. Roll carefully this folded portion, as tight as possible into a cylinder.
4. Push this cylinder through center hole of filter plate.
5. Spread rolled cloth out on back side of plate. Turn cloths until grommets are properly positioned to plate.

INTERMEDIATE BARRELNECK CLOTH

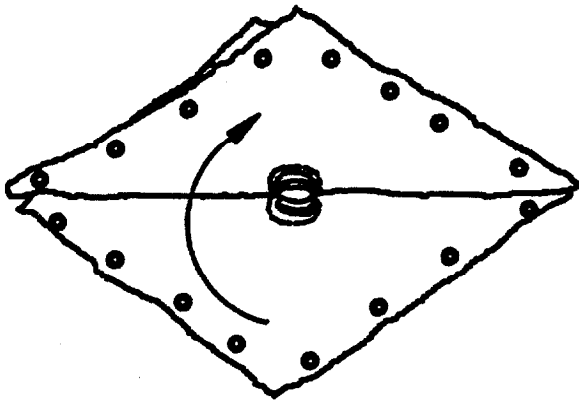

FIG 1

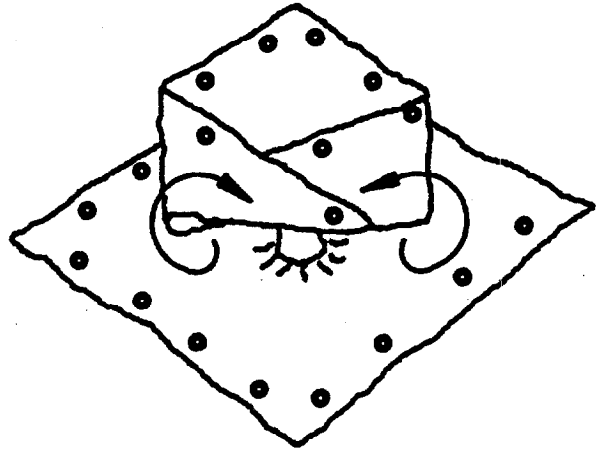

FIG 2

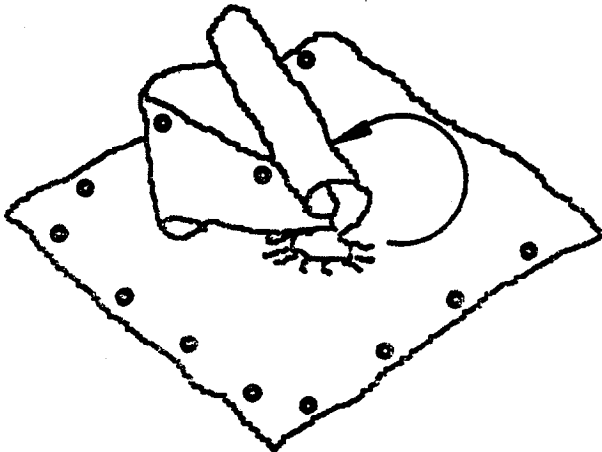

FIG 3

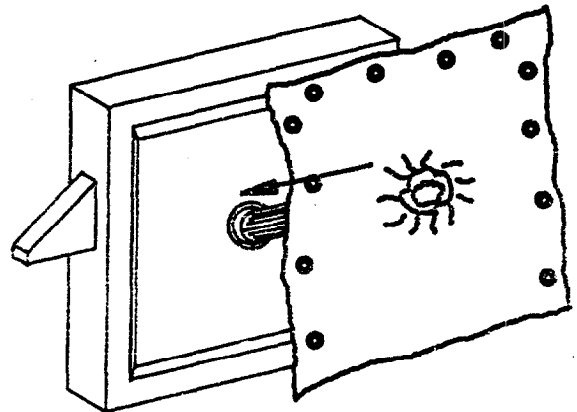

FIG 4

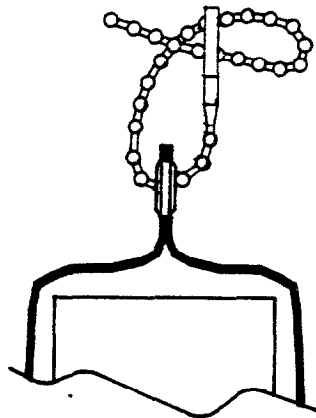
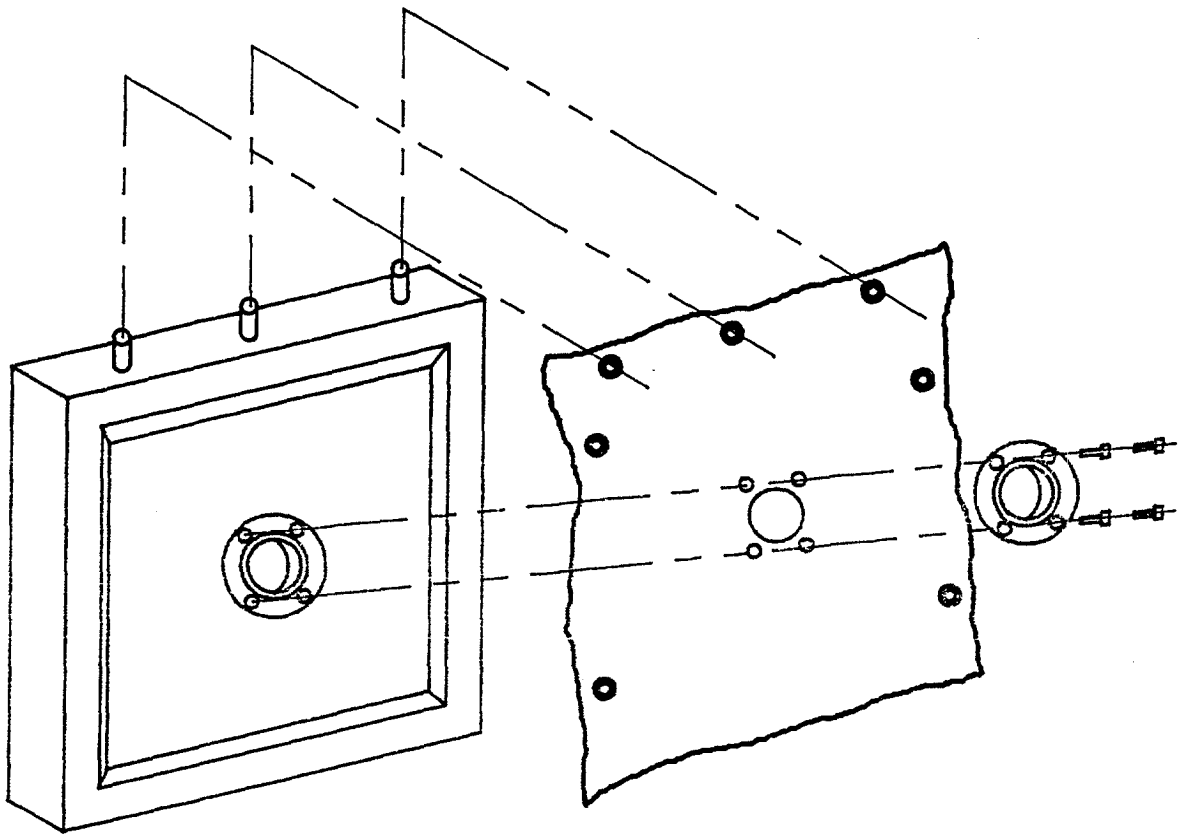

FIG 5
PLASTIC TIE
INSTALLATION DETAIL

DWG 41175110

HEAD & END CLOTH



SECTION III: TROUBLESHOOTING AND MAINTENANCE

Chapter IX Process Troubleshooting

Chapter X Filter Press Troubleshooting

Chapter XI General Maintenance

Chapter IX

PROCESS TROUBLESHOOTING

The following is a list of common operational problems associated with the Filter Press filtration process:

| <u>Problem</u> | <u>Cause</u> | <u>Remedy</u> |
|--|---|---|
| Slurry leaking from plates | Low hydraulic pressure | Increase hydraulic pressure and check for leaks. |
| | Wrinkle or hole in filter cloth | Replace filter cloth. |
| | Sealing surface dirty | Use nylon cake scraper to remove cake from sealing surface. |
| | Possible plate warpage | Replace plate. Check pressure and temperature of system. |
| Plate breakage | Press is not square and level | Check alignment. See Chapter V. |
| | Solids build-up in slurry feed pipe causing pressure differential | Clean slurry feed pipe and plate feed hole. |
| Plate pack has risen above side-rails during closing | Solids build-up in filtrate holes - reducing flow | Clean filtrate holes in plate. |
| | Filter plates not aligned properly | Reshift plates against the headplate. |
| Cloudy filtrate | Filter plate pack not square | Sealing surface of plates and cloths dirty - clean. |
| | Holes in filter cloths | Replace filter cloths. |
| | Process changes | Consult Netzsch Incorporated. |

Netzsch 630LP Filter Press
Troubleshooting (Continued)

Slurry pump stalls,
indicating the press is
full. But when the press
is opened, an egg shelled
cake is formed

Clogged feed eye
feed eyes.

Use cake scraper to clean.

Filter cloths plugged

Clean or replace filter cloths
as necessary.

Process changes

Consult Netzsch Incorporated.

Sludge pump air pressure
is too low

Increase pressure
accordingly.

Chapter X

FILTER PRESS TROUBLESHOOTING

| <u>Problem</u> | <u>Cause</u> | <u>Remedy</u> |
|---|--|---|
| Loss of hydraulic pressure | Low air pressure | Increase air pressure to a minimum of 70 psig. |
| | Air leaks due to defective tube or fitting | Locate and replace. |
| | Low oil level | Check oil level and fill. |
| | Defective component which is worn or jammed due to contamination from improper filtered air supply | Clean component and check air filtering system. |
| Closure system will not reach system pressure | Hydraulic cylinder seals leaking | Replace seals. |
| | Low air pressure | Increase air pressure to reach desired hydraulic pressure. |
| | System relief valve set incorrectly or leaking. | Check schematic and repair. |
| | Hydraulic cylinder seals leaking | Replace seals. |
| | Air in hydraulic circuit | Purge trapped air, loosen hydraulic gauge during "retract" until air escapes. |
| | Cylinder extended to end of stroke | Check if filter plates were removed from plate pack. |
| | Hydraulic pump malfunction | Check manufacturer's manual for troubleshooting guide. |
| Hydraulic cylinder will not retract | Defective hydraulic pressure gauge | Check hydraulic pressure gauge calibration. |
| | Broken spring | Check hydraulic cylinder. |
| | Air/Oil circuit defective part | Check Air/Oil logic for defective |

NOTE: Refer to the manufacturer's manual for further troubleshooting techniques. A pneumatic/hydraulic logic schematic is provided in Section 7.

Chapter XI

GENERAL MAINTENANCE

1. Air/Oil Hydraulic Closure System

Note: It is very important in an air/oil hydraulic power unit to have contaminant removal devices such as air and oil filters.

MONTHLY

- A. Check hoses for leaks.
- B. Wipe down all components to remove oil film or dirt.
- C. Check oil level and maintain to fill line on tank.

YEARLY

- A. Drain and replace hydraulic oil. Oil should be SAE 10, rated at 200 SUS @ 100° F or equal.
- B. Remove muffler/filters and clean in solvent or cleaner.

2. Hydraulic Cylinder

- A. The hydraulic cylinder will be automatically lubricated by the hydraulic oil.
- B. Keep the piston rod free from dirt or sludge at all times.

3. Side Rails

- A. The PVC-lined side rails should always be clean to avoid wear damage to the filter plate handles.

4. Air Maintenance

A correct plumbing design of the inlet air supply is crucial to eliminate the majority of water, oil and particles from entering the filter press hydraulic power unit. This will extend the life of both hydraulic and pneumatic components. The air line to the hydraulic power unit should be plumbed from the top of the main line instead of the bottom. This will prevent water that has condensed and is sitting at the bottom of the main line from being drawn down into the filter press. An air dryer is recommended if extreme amounts of water are present. Air lubrication should not be used.

5. Filter Plates and Cloths

WEEKLY

- A. Check filter plates sealing surfaces for slurry build-up. Clean as necessary.
- B. Check filter cloth for slurry build-up. Pressure wash or pad wash cloths as process dictates.

YEARLY

- A. Replace filter cloths depending on filter press utilization and process results. The average life of a filter cloth is approximately 1500 filtration cycles.

6. Filter Cloth Installation

In order to put a set of filter cloths on the filter plates, whether it be a new press or simply changing the filter cloths, the following steps should be taken. The design of the cloths used by Netzsch allows the mounting of the cloths without removing the filter plates from the press. The procedure is simple and takes little time to accomplish.

1. By laying on a flat surface, fold one section of cloth diagonally to create a diaper shape.
2. Fold edges so they overlap.
3. Roll carefully this folded portion, as tight as possible, into a cylinder.
4. Push this cylinder through center hole of filter plate.

5. Spread rolled cloth out on back side of plate. Turn cloths until grommets are properly positioned to plate.
6. Attach ties to cloths to secure cloths to plates. After closing the tie, force the remaining end of the tie back through the loop.
7. Apply end cloths as shown on attached drawing.
8. To remove cloths, simply undo ties and pull cloth through center hole.

7. Filter Cloth Cleaning Instructions

The filter cloths provided have been selected for your particular slurry application.

During the filtration process the filter cloth initially separates the solids from the liquid, thus, the filter cloth must maintain its porosity. Eventually, the filter cloth will become embedded with tiny minute particles. This will cause a "blinding effect" which leads to decreased filtration. The particles must be removed periodically to maintain an optimal filtration process.

There are several reasons why cleaning the filter cloths are required. Listed below are the main reasons for cleaning:

1. High use of Calcium Hydroxide
2. Long filtration cycles
3. Reduction cake solids
4. Initial high filtration pressure (40 - 50 psig)

Methods for Cleaning

1. Wash the filter plates and cloths with a portable high pressure cold water washer (1000 - 1500 psi at 5-15 GPM). A power wash with nozzle can be used to spray the plates and cloths. The high pressure washer will clean the surface of the plates and cloths but also the internal weave of the filter cloth.

The frequency of cleaning is determined upon the process filtration application.

2. Manual Acid Wash - Wash the filter cloths and plates with water, either by hand or with a high pressure washer. Prepare a 5-10% solution of muratic acid in a polyethylene container.

Then "dipwash" the cloths and plates in the tank. This will probably require several hours to clean the internal weave of the cloth. Remove the plates and cloths and wash with water again.

Continuous Acid Wash - A continuous acid recirculation wash system can be utilized by installing the proper feed and filtrate piping on the filter press. Consult Netzsch Incorporated for further details if required.

SECTION IV: OPERATION DESCRIPTION

Chapter XII Filtration Cycle

Chapter XIII Core Blow

Chapter XIV Sequence of Operations

Chapter XII

FILTRATION CYCLE

The filtration cycle will begin by starting the feed system. The slurry enters the Filter Press through the feed inlet in the center of the head plate assembly. The cavities of the filter plate chambers will be filled with slurry. After a certain period of time, the filtrate will discharge through the spigots of the filter plates into the filtrate trough (filtrate discharge through corner ports with closed filtrate plates is optional). Leakage of filter cloths and cloudy filtrate might appear during the first few minutes. This is a normal happening due to new filter cloths and should disappear after a short time.

The amount of filtrate decreases during the cycle as the chambers fill with solids. Therefore, the flow rate of the feed systems has to be reduced accordingly.

With the increase of the solid concentration in the Filter Press chamber, the filtration pressure will increase. The maximum pressure for the Netzsch 630LP Filter Press is 105 psi.

After reaching the maximum pressure, the filtration cycle is not automatically completed. The cycle is finished when the desired solid concentration in the filter cake is reached.

The solid concentration of the filter cake depends on the following parameters:

1. Selection of filter cloth material.
2. Condition of the filter cloths. The filter cloths have to be cleaned (washed) after a certain period of use depending on the application.
3. Operating pressure of the machine (feed system).
4. Flow control and pressure of the feed system.
5. The time of the dewatering cycle.
6. The pre-treatment and condition of the slurry.

In order to achieve the desired solid concentration in the filter cake, empirical tests are required. As a general rule, the maximum flow decreases to its minimum flow. Solids concentration test during the cycle is not possible.

End of Filtration Cycle

1. The feed system has to shut off, either manually or automatically by the control system.
2. Relieve pressure of the Filter Press. For those presses which are not equipped with a core blow device, we recommend installing, in the feed line, a pressure relief valve. If a feed system is used which allows an internal pressure relief, this valve might not be needed. However, we recommend that a valve should isolate the Filter Press from the slurry supply during all cycles except when feeding.

Chapter XIII

CORE BLOW

Most of the Netzsch Filter Presses are equipped with either a manual or automatic core blow device. In the center feed hole of the filter plates, and naturally in the feed line, there is normally no filtration. As a result, a residue of wet matter remains in this area, even if a dry cake in the chamber is obtained. This matter has to be removed. The most efficient way to remove this matter is to blow it out with forced air in the direction of the feed entrance of the Filter Press. Therefore, in manual or automatic, a 3-way valve or two 2-way manual valves at the feed inlet of the Filter Press are required.

The standard equipment for a Netzsch Filter Press is the end/core blow combination plate. This plate is the last filter plate in the plate pack. On top of this plate, an air connection for compressed air is located.

The average requirements: 80-110 psi air pressure

NOTE: The greater the air pressure, the shorter the blow time.
Average blow times are 60 to 180 seconds.

The core blow return position at the 3-way valve also allows pressure relief of the system before opening the Filter Press.

Manual Core Blow Device

The manual core blow device consists of air blow connection plate, plant air supply, manual shut-off valve, check valve to avoid sludge return, and a manual 3-way valve or two 2-way manual valves.

Sequence of Operations:

When the filtration cycle is finished, the operator switches the 3-way valve or 2-way manual valve to core blow position (core return to sludge holding tank). Then he opens the shut-off valve at the air supply. This valve stays open as long as is necessary. When the core blow is finished, he shuts off the valve and opens the Filter Press for cake discharge. The core blow position of the 3-way also guarantees that the press itself is pressure-less prior to cake discharge.

The same device can also be used to air-dry the cake. In this case, the 3-way valve remains in the closed position.

Chapter XIV

SEQUENCE OF OPERATIONS

Operating Description

To Close Press: Make sure that there are no particles on the surface of the filter cloths or between the plates.

1. Move all of the intermediate plates toward the head plate. The plates should be brought back straight and aligned correctly. Check for creases and holes in the filter cloths.
2. Press the “extend” push button to close the Filter Press. The switch must be held until a pre-set pressure limit is met, which will continue the closing device until maximum pressure is reached.

To Begin Feed System:

1. Open the valve between the pump and Filter Press and close the core blow relief valve.
2. Begin the filtration cycle by selecting the “ON” selector switch located on the traverse of the Filter Press. The air switch will energize the pilot valve located at the sludge feed pump. The feed pump will begin to pump sludge based upon the air pressure and volume applied to the pump.
3. The feed cycle is finished when the desired cake solids concentration or minimum filtrate volume is met.

NOTE: Do not open Filter Press while under sludge feed pumping pressure.

To Open Press:

1. Turn off feed pump by selecting “OFF”.
2. Close the valve between the pump and Filter Press, and open the core blow relief valve.
3. Open the manual core blow return valve (located on traverse assembly). Average core blow air times are 60 - 180 seconds.
4. Close manual core blow valve.

5. Open the manual filtrate air blow valve and close the top filtrate valve. The air will remove any remaining filtrate in filtrate lines out of the bottom two filtrate ports. Average filtrate blow air times are 60 - 180 seconds.
6. Close air valve and reopen filtrate valve.
7. Position cake dumpster or any other means of disposing of the filter cake under the filter plates.
8. Press the "retract" push-button to open the Filter Press. The hydraulic cylinder will retract.
9. Move each intermediate plate back one at a time against the end plate.

The next filtration cycle can be initiated when all of the filter cakes have been dropped.

SECTION V: SPARE PARTS

All spare parts inquiries can be handled through the following office:

Netzsch Incorporated
119 Pickering Way
Exton, PA 19341-1393
Attn: Filtration Division

Phone: 610.363.8010
Fax: 610.363.0971

Netzsch Direct Return Policy

All returns require an Equipment Authorization Return (ERA) number. Netzsch will not process your return or issue proper credit without an approved ERA number.

All returns must be complete and must be received within 21 days of issuing the ERA number.

The ERA number must appear on all boxes being returned. Nonconformance to this policy will result in replacement delays and unsolved credit issues.

C.O.D. shipments will not be accepted.

Netzsch Air/Oil Hydraulic Unit

Spare Parts List

| PART NUMBER | DESCRIPTION |
|--------------------|-----------------------|
| 652476 | Haskel Hydraulic Pump |
| 652384 | Clippard Valve, MAV-3 |
| 652471 | Clippard Valve, R-302 |
| 652507 | Clippard Valve, R-321 |
| 652472 | Push-button, Red |
| 652473 | Push-button, Green |
| 652385 | Push-button, Adapter |
| 652534 | Regulator |
| 652478 | Release Valve |
| 652590 | Air Pilot Switch |

RECOMMENDED SPARE PARTS LIST

M. C. B. CAMP LEJEUNE

SOIL AND GROUNDWATER REMEDIATION-OU NO. 2

NETZSCH JOB NO. 0401087695

| QTY. | DESCRIPTION | PART NO. |
|-------------|-----------------------------|-----------------|
| 1 | CAKE SCRAPER | 641574 |
| 1* | CLOTH PLASTIC TIE | 640864 |
| 1* | INTERMEDIATE FILTER CLOTH | 695384 |
| 1 | HEAD FILTER CLOTH | 695416 |
| 1 | END FILTER CLOTH | 695415 |
| 1* | INTERMEDIATE FILTER PLATE | 695599 |
| 1 | HYDRAULIC CYLINDER SEAL KIT | 426685 |
| 1 | HYDRAULIC PRESSURE GAUGE | 651562 |

*** QUANTITIES MAY VARY ON REQUEST**

SECTION VI: MANUFACTURER'S MANUALS

Procedure for Replacing Sealing Kits

Hydraulic Closure

1. Remove cylinder from Filter Press.
2. Remove screw (part #13). Use an 8mm Allen head wrench.
3. Remove guide for piston rod (part #3). Use a Spanner wrench to remove.
4. After the guide is unscrewed, the piston rod with piston can be removed.
5. Remove (part #11 and #4). After removing this, the piston seal (part #8) can be replaced.
6. Reassemble piston with new seals. Replace wiper seal (part #15).
7. Reassemble cylinder to Filter Press.
8. Bleed air out of hydraulic system by slowly unscrewing hydraulic pressure gauge until no air bubbles exist.

Hydraulic cylinder sealing kit part #426685

Hydraulic cylinder part #690339

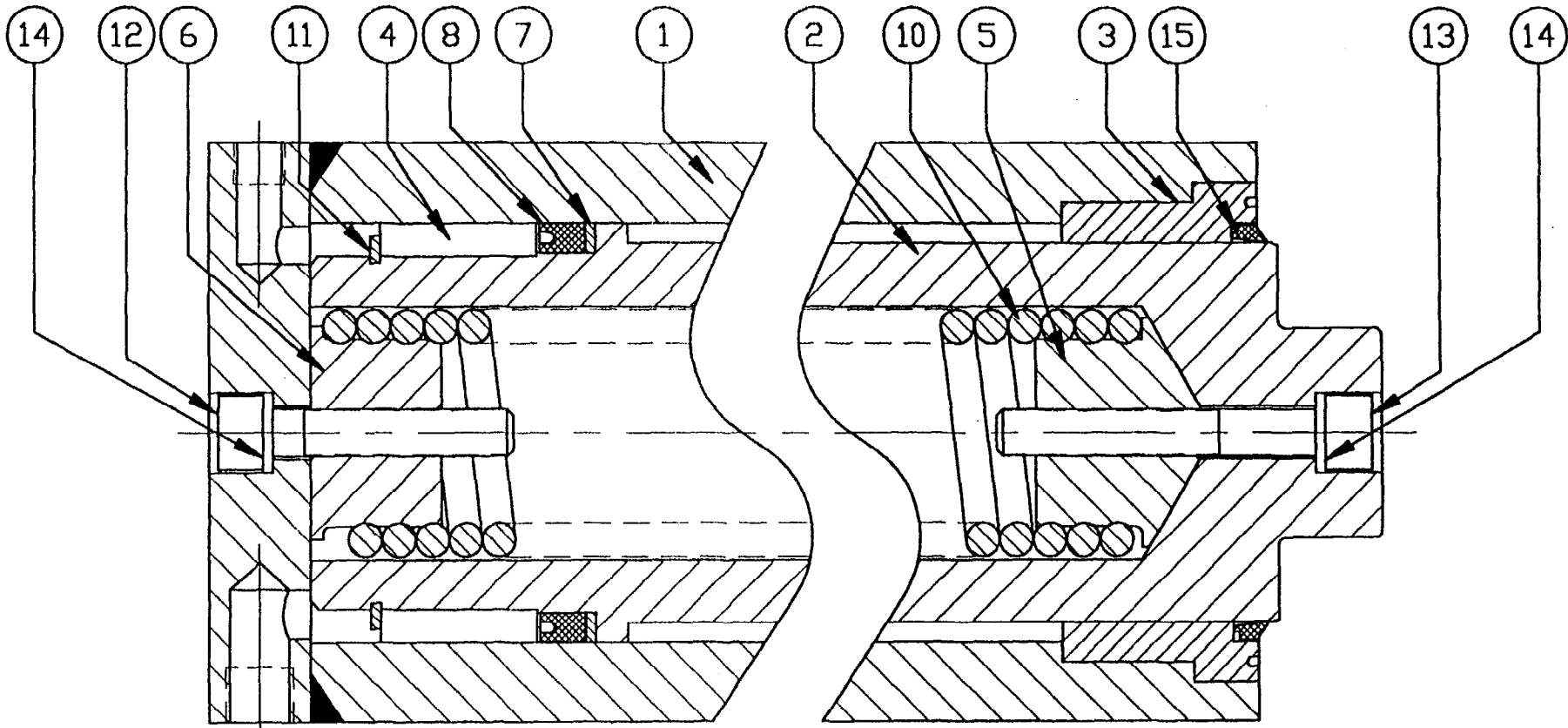

PART # 690339

| | | | | | |
|---|---------------|-----------------------|----------------|--------------|---------|
| | | | | | |
| | | | | | |
| | | | | | |
| | | | | | |
| REV. | DESCRIPTION | | BY | DATE | APP'D. |
| | | | | | |
|  | | NETZSCH INC. | | | |
| | | EXTON, PA. 19341-1393 | | | |
| TITLE HYDRAULIC CYLINDER FILTER PRESS | | | | | |
| DRAWN TH | DATE 08/10/90 | CHK'D | | DATE | |
| SCALE .625=1 | | APP'D | <i>Billars</i> | DATE 8/13/90 | |
| SHEET NUMBER | of | SIZE | DRAWING NUMBER | | |
| | | | A 41034110 | | |
| ORDER/PROJECT NUMBER | | | | | SHT REV |

COMPLETE PRODUCT STRUCTURE DETAIL -

SORTED BY COMPONENT PART NUMBER

ASSY: 696554 DESC: POWER PACK AIR/OIL 470MM & 630MM LP ASSY
 DWG-ID: D-41097112 REV: 2 BUILD QTY: 1

| COMPONENT PART | DESCRIPTION | QPA | TOTAL/QPA | UM | REF-DE |
|----------------|---|-------------------|------------|----|--------|
| MASTER BIN | -- P R O D U C T I N F O -- | MFG NAME | MFG NUMBER | | |
| 630549 | TUBING POLYETHYLENE .375 OD*.062 WALL 125PSIG MAX | 90 | 90 | IN | 45 |
| 2/296 | | PARKER | E-64-0500 | | |
| 649119 | WASHER LOCK #10 PLATED. | 2 | 2 | EA | 53 |
| 6/012 OP | | BUILDCO FASTENING | 649119 | | |
| 649120 | WASHER LOCK .250" PLT | 8 | 8 | EA | 54 |
| 6/013 OP | | LUFASCO | | | |
| 649144 | WASHER FLAT .250" PLT | 4 | 4 | EA | 60 |
| 6/016 OP | 132/LB. | | 649144 | | |
| 649278 | SCREW RD HD MACH 10-32*1.250 PLT | 2 | 2 | EA | 50 |
| 6/030 OP | | BUILDCO FASTENING | 649278 | | |
| 649304 | WASHER LOCK #8 | 2 | 2 | EA | 52 |
| 6/012 OP | | HATTS | 649304 | | |
| 649311 | SCREW HEX HD CAP .250-20*.750 PLT | 8 | 8 | EA | 51 |
| 6/095 OP | | | | | |
| 649479 | PIPE NIPPLE 0.250 NPT*CLOSE BRASS | 3 | 3 | EA | 42 |
| 6/482 | | | 649479 | | |
| 649479 | PIPE NIPPLE 0.250 NPT*CLOSE BRASS | 1 | 1 | EA | 64 |
| 6/482 | | | 649479 | | |
| 649637 | PIPE CPLG THRD .500 NPT BRASS | 1 | 1 | EA | 57 |
| 6/491 | | MCMASTER CARR | 4429K113 | | |
| 649774 | SCREW RD HD MACH 8-32*1.750 PLT | 2 | 2 | EA | 49 |
| 6/027 | | LUFASCO | | | |
| 650433 | PIPE BUSHING HEX .500*.375 BRASS | 3 | 3 | EA | 26 |
| 2/427 | | | | | |
| 650696 | PIPE CPLG THRD .250 NPT BRASS | 1 | 1 | EA | 65 |
| 6/491 OP | | | | | |
| 650857 | BULKHEAD FITTING 1/4 NPTF BRASS | 2 | 2 | EA | 33 |
| 6/479G | | PARKER | 207ACBHS-4 | | |

COMPLETE PRODUCT STRUCTURE DETAIL -

SORTED BY COMPONENT PART NUMBER

ASSY: 696554 DESC: POWER PACK AIR/OIL 470MM & 630MM LP ASSY
 DWG-ID: D-41097112 REV: 2 BUILD QTY: 1

| COMPONENT PART | DESCRIPTION | QPA | TOTAL/QPA | UM | REF-DE |
|----------------|--|---------------------|-----------------|----|--------|
| MASTER BIN | -- P R O D U C T I N F O -- | MFG NAME | MFG NUMBER | | |
| 651370 | TUBE FTG MALE CONN .375 TUBE*.250 NPT BRASS | PARKER | 68P-6-4 | EA | 27 |
| 6/498 | | | | | |
| 651381 | MUFFLER SINTERED .250 NPT MALE | NORGREN | MS002A | EA | 40 |
| EXC 4 | | | | | |
| 651961 | PIPE BUSHING HEX .500*.250 STEEL | PARKER | .500*.250 PTR S | EA | 43 |
| EXC 4 | | | | | |
| 651973 | PIPE PLUG HEX HEAD .500 STEEL | PARKER | .500 HP S | EA | 56 |
| EXC 4 | | | | | |
| 651990 | PIPE PLUG SKT HD .375 NPT BRASS | MERIT BRASS | BS118HC-06 | EA | 61 |
| 6/479E | COUNTER SUNK | | | | |
| 651991 | PIPE PLUG SKT HD .250 NPT BRASS | MERIT BRASS | BS118HC-04 | EA | 41 |
| 6/479D | COUNTERSUNK | | | | |
| 652241 | TUBE FTG UNION TEE .375 OD BRASS | PARKER | 164P-6 | EA | 31 |
| 6/485 | | | | | |
| 652303 | FITTING "L" TYPE 10-32 * 1/8" BRASS | CLIPPARD | 15090-1 | EA | 16 |
| EXC 5 | | | | | |
| 652304 | HOSE POLYURETHANE 1/8" ID BLACK | CLIPPARD | 3814-6 BLACK | IN | 20 |
| 4/118 | | | | | |
| 652305 | PLUG SCREW 10-32 THD BRASS | CLIPPARD | 11755 | EA | 19 |
| EXC 5 | | | | | |
| 652306 | FITTING BARB 10-32THD * 1/8" ID HOSE BRASS | BESWICK ENGINEERING | MH-1332-1/4 HEX | EA | 17 |
| EXC 5 | WAS CLIPPARD #11752-3 | | | | |
| 652310 | STAND-OFF KIT W/HARDWARE FOR CLIPPARD VALVES | CLIPPARD | R-107-20 | KT | 12 |
| EXC 6 | | | | | |
| 652312 | SUBPLATE WITH EXTENSIONS FOR CLIPPARD VALVES | CLIPPARD | R-101 | EA | 10 |
| EXC 6 | | | | | |
| 652315 | VALVE AIR SHUT OFF .250 NPT | NORGREN | T08-200-E1PA | EA | 8 |
| 4/124 | | | | | |

COMPLETE PRODUCT STRUCTURE DETAIL -

SORTED BY COMPONENT PART NUMBER

SSY: 696554 DESC: POWER PACK AIR/OIL 470MM & 630MM LP ASSY
 DWG-ID: D-41097112 REV: 2 BUILD QTY: 1

| COMPONENT PART | DESCRIPTION | QPA | TOTAL/QPA | UM | REF-DE |
|----------------|---|----------|---------------|----|--------|
| MASTER BIN | -- P R O D U C T I N F O -- | MFG NAME | MFG NUMBER | | |
| 652323 | FITTING "T" TYPE #10-32 BRASS | 1 | 1 | EA | 24 |
| EXC 5 | | CLIPPARD | 15002-3 | | |
| 652324 | ADAPTER PIPE TO FEMALE 1/4"NPT TO #10-32 BRASS | 1 | 1 | EA | 25 |
| EXC 5 | | CLIPPARD | 15006-3 | | |
| 652384 | VALVE 3-WAY POPPET NC 15/32 * #10-32 PORTS | 2 | 2 | EA | 9 |
| EXC 7 | | CLIPPARD | MAV-3 | | |
| 652385 | VALVE ADAPTOR | 2 | 2 | EA | 15 |
| EXC 7 | | CLIPPARD | PB-85 | | |
| 652469 | MTG STRIPS FOR CLIPPARD VALVES | 2 | 2 | EA | 11 |
| EXC 6 | | CLIPPARD | R-102-3 | | |
| 652471 | VALVE 3-WAY NO/NC | 1 | 1 | EA | 6 |
| EXC 7 | | CLIPPARD | R-302 | | |
| 652472 | PUSHBUTTON EXTENDED SPRING RETURN RED | 1 | 1 | EA | 14 |
| EXC 7 | | CLIPPARD | PS-P2E-R | | |
| 652473 | PUSHBUTTON FLUSH SPRING RETURN GREEN | 1 | 1 | EA | 13 |
| EXC 7 | | CLIPPARD | PS-P2F-G | | |
| 652474 | TANK AIR/OIL 200 PSI 6" BORE 137 CU IN TA SERIES | 1 | 1 | EA | 2 |
| PR 22F | | LIN-ACT | TA-6*8 | | |
| 652476 | PUMP HYDRAULIC AIR/OIL .33HP 110:1 1/4"NPT PORTS | 1 | 1 | EA | 3 |
| EXC 3 | W/EXTERNAL PILOT | HASKEL | 51811-M-110 | | |
| 652478 | VALVE RELEASE 2-WAY NC, PLT, BUNA-N, PTFE 15K-10K PSI | 1 | 1 | EA | 4 |
| EXC 3 | | HASKEL | 28940-1 | | |
| 652479 | VALVE 3-WAY AIR PILOT OPERATED .250 NPTF | 1 | 1 | EA | 21 |
| EXC 8 | .125 NPTF PILOT PORT, SPRING RETURN | ISI/OMNI | 375-02-007-03 | | |
| 652480 | TUBE FTG MALE CONN .375 TUBE * .375 NPT BRASS | 1 | 1 | EA | 28 |
| 6/479F | | PARKER | 68P-6-6 | | |
| 652481 | TUBE FTG MALE RUN TEE .375 TUBE * .250 NPT BRASS | 1 | 1 | EA | 32 |
| 6/479E | | PARKER | 171P-6-4 | | |

COMPLETE PRODUCT STRUCTURE DETAIL -

SORTED BY COMPONENT PART NUMBER

ASSY: 696554

DESC: POWER PACK AIR/OIL 470MM & 630MM LP ASSY

DWG-ID: D-41097112

REV: 2

BUILD QTY:

1

| COMPONENT PART | DESCRIPTION | QPA | TOTAL/QPA | UM | REF-DE |
|----------------|--|---------------------|---------------|----|--------|
| MASTER BIN | -- P R O D U C T I N F O -- | MFG NAME | MFG NUMBER | | |
| 652482 | TUBE FTG MALE ELL .375 TUBE * .250 NPT BRASS | 4 | 4 | EA | 29 |
| 6/479B | | PARKER | 169P-6-4 | | |
| 652483 | TUBE FTG MALE ELL .375 TUBE * .375 NPT BRASS | 4 | 4 | EA | 30 |
| 6/483 | | PARKER | 169P-6-6 | | |
| 652485 | PIPE FITTING DRAIN COCK .250 NPT MALE BRASS | 1 | 1 | EA | 34 |
| 6/479G | | PARKER | DC602-4 | | |
| 652486 | TUBE FTG MALE BRANCH TEE .375 TUBE * .250 NPT M ST 2 | 2 | 2 | EA | 38 |
| 6/479C | | PARKER | 6-SBU-S | | |
| 652488 | TUBE FTG BULKHEAD UNION .375 TUBE STEEL | 1 | 1 | EA | 39 |
| 6/479G | | PARKER | 6-WBU-S | | |
| 652494 | MANIFOLD 4-PORT .250 NPT M20-250-4 | 1 | 1 | EA | 23 |
| 6/332 | | PNEUMADYNE/DEVAIR | M20-250-4 | | |
| 652498 | PIPE NIPPLE 0.500 NPT * 08.000 BRASS | 1 | 1 | EA | 58 |
| 6/479I | | | | | |
| 652499 | GROMMET 1.250 DIA RUBBER | 1 | 1 | EA | 59 |
| 4/007 | | MCMaster-CARR | 9602K16 | | |
| 652507 | VALVE 3-WAY COMBINATION | 1 | 1 | EA | 7 |
| EXC 8 | | CLIPPARD | R-321 | | |
| 652533 | FILTER AIR 1/4"NPT | 1 | 1 | EA | 46 |
| EXC 9 | | NORGREN | F08-200-M3DA | | |
| 652534 | REGULATOR AIR PRESSURE 1/4"NPT 5-150PSI | 1 | 1 | EA | 22 |
| EXC 9 | RELIEVING WITH PRESSURE GAUGE | NORGREN | R-08-200-RGMA | | |
| 652590 | VALVE PRESSURE SENSING 2-WAY N.C. SET @ 400PSI INC | 1 | 1 | EA | 5 |
| EXC 8 | SEE CANNED MESSAGE | HASKEL | 28898-3 | | |
| 652593 | TUBE FTG MALE CONN .375 TUBE * .250 NPT MALE ST | 1 | 1 | EA | 35 |
| 6/479H | | PARKER | 6FBUS | | |
| 652595 | FITTING BARB "T" * 1/8 ID HOSE BRASS | 7 | 7 | EA | 18 |
| 6/479E | | BESWICK ENGINEERING | MHT-3332 | | |

COMPLETE PRODUCT STRUCTURE DETAIL -

SORTED BY COMPONENT PART NUMBER

ASSY: 696554 DESC: POWER PACK AIR/OIL 470MM & 630MM LP ASSY
 DWG-ID: D-41097112 REV: 2 BUILD QTY: 1

| COMPONENT PART | DESCRIPTION | QPA | TOTAL/QPA | UM | REF-DE |
|----------------|---|---------------|-----------------|----|--------|
| MASTER BIN | -- P R O D U C T I N F O -- | MFG NAME----- | -----MFG NUMBER | | |
| 669727 | TUBING HYDRAULIC .375 OD*.065 WALL STL | | 30 | 30 | IN 44 |
| STEEL | | | | | |
| 690295 | LOGOPLATE-NETZSCH RD. 4" | | 1 | 1 | EA 47 |
| 4/212 | DIECAST | LA FRANCE CO | | | |
| | 215-365-8000 | | | | |
| 696320 | PANEL ENCLOSURE AIR/OIL 470MM & 630MM | | 1 | 1 | EA 55 |
| PR 15G | | | | | |
| 696321 | ENCLOSURE LAYOUT 470MM & 630MM LP AIR/OIL | | 1 | 1 | EA 1 |
| | NIL | | | | |
| 696441 | NAMEPLATE AIR/OIL POWER PACK SPECIAL NOTICE | | 1 | 1 | EA 36 |
| | "NOTICE! OPERATOR MUST CLOSE | | | | |
| | PRESS FROM IN FRONT OF PANEL" | | | | |
| 696558 | LABEL "EXTEND" | | 1 | 1 | EA 48 |
| | .5"*2.0" BLACK LAMICOID W/.19" | NIL | | | |
| | HIGH WHITE LETTERS | | | | |
| 696559 | LABEL "RETRACT" | | 1 | 1 | EA 62 |
| | .5"*2.0" BLACK LAMICOID W/.19" | NIL | | | |
| | HIGH WHITE LETTERS | | | | |
| 696560 | LABEL "OIL FILL" | | 1 | 1 | EA 63 |
| | .5"*2.0" BLACK LAMICOID W/.19" | NIL | | | |
| | HIGH WHITE LETTERS | | | | |

NEMA/EEMAC Type 1 Enclosures



N1A Series

Non-ventilated, Inner Panel Included



A6

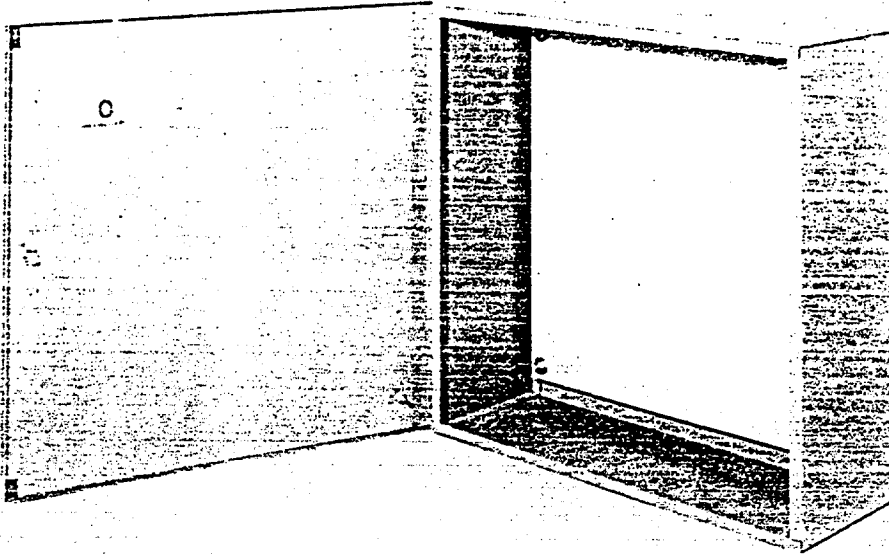

Application

- designed for general purpose indoor non-ventilated applications which do not require oil-tight and dust-tight protection

Standards

- NEMA/EEMAC Type 1
- those models marked \odot are UL 50 listed Type 1
- CSA certified enclosure 1 LR21001

Construction

- formed and spot welded from 14 ga. steel
- removable door with slip hinges and quarter turn latch, doors 30" and higher provided with two latches
- 12 or 14 ga. removable steel panels mounted on collar studs
- mounting holes in back of enclosure are standard
- optional mounting flanges are available for external mounting

Finish

- enclosures are phosphatized and finished with ANSI/ASA 61 gray baked recoatable enamel
- inner panels are finished in white enamel

Accessories

- see page J4 for spare inner panels
- oversized inner panels are available to allow a Hammond 1420 Series user to retain the 1420 panel size in the N1A enclosure, see page J4

External Mounting Brackets

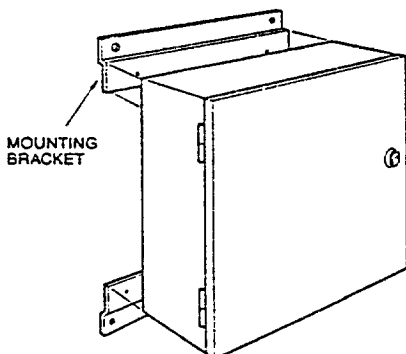

- Optional mounting brackets are available to provide external mounting of N1A enclosures where required. When the external mounting brackets are used, the mounting centers will match those of a Hammond 1420 Series enclosure of the same size.

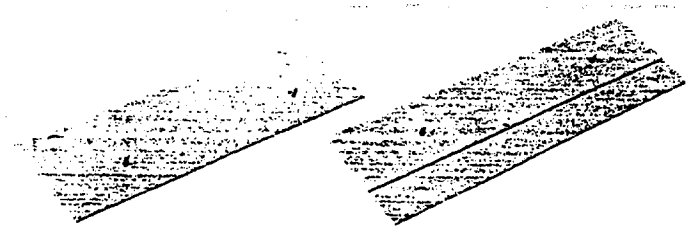

| Part No. | Enclosure Width (In.) |
|----------|-----------------------|
| AMF 12 | 12 |
| AMF 16 | 16 |
| AMF 20 | 20 |
| AMF 24 | 24 |
| AMF 30 | 30 |
| AMF 36 | 36 |



NEMA/EEMAC Type 1 Enclosures

N1A Series
Non-ventilated,
Inner Panel Included



A7

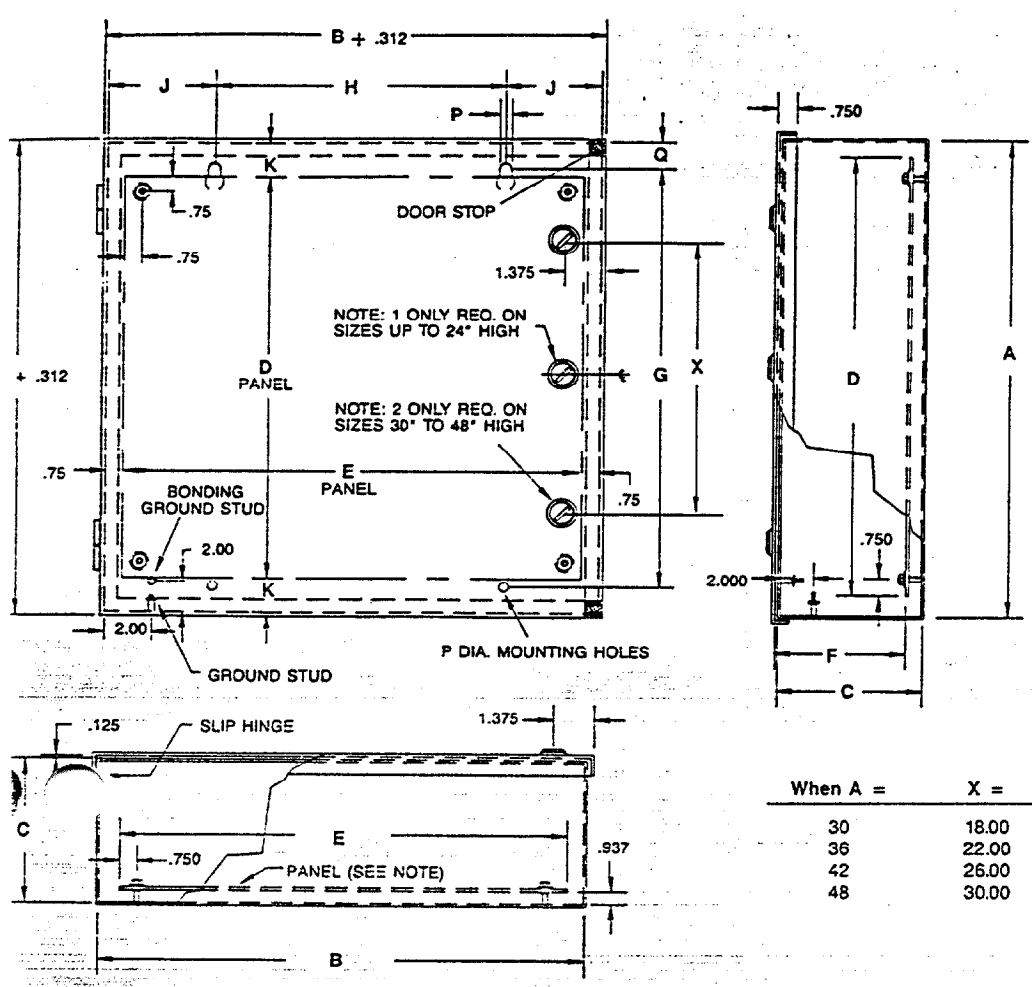

| When A = | X = |
|----------|-------|
| 30 | 18.00 |
| 36 | 22.00 |
| 42 | 26.00 |
| 48 | 30.00 |

| Part No. | A | B | C | Panel Size | | Panel Gauge | No. of Studs | Mounting Dimensions | | | | | Panel Clearance | | Ship Wt. lbs. |
|------------|-------|-------|-------|------------|-------|-------------|--------------|---------------------|-------|------|------|------|-----------------|------|---------------|
| | | | | D | E | | | G | H | J | Q | P | F | K | |
| N1A 16127 | 16.00 | 12.00 | 7.00 | 13.00 | 10.50 | 14 | 4 | 13.88 | 7.00 | 2.50 | 1.06 | 0.31 | 6.04 | 1.50 | 24.54 |
| N1A 16167 | 16.00 | 16.00 | 7.00 | 13.00 | 14.50 | 14 | 4 | 13.88 | 11.00 | 2.50 | 1.06 | 0.31 | 6.04 | 1.50 | 30.36 |
| N1A 16207 | 16.00 | 20.00 | 7.00 | 13.00 | 18.50 | 14 | 4 | 13.88 | 15.00 | 2.50 | 1.06 | 0.31 | 6.04 | 1.50 | 36.12 |
| N1A 20167 | 20.00 | 16.00 | 7.00 | 17.00 | 14.50 | 14 | 4 | 17.88 | 11.00 | 2.50 | 1.06 | 0.31 | 6.04 | 1.50 | 36.58 |
| N1A 20207 | 20.00 | 20.00 | 7.00 | 17.00 | 18.50 | 14 | 4 | 17.88 | 15.00 | 2.50 | 1.06 | 0.31 | 6.04 | 1.50 | 43.40 |
| N1A 24167 | 24.00 | 16.00 | 7.00 | 21.00 | 14.50 | 14 | 4 | 21.88 | 11.00 | 2.50 | 1.06 | 0.31 | 6.04 | 1.50 | 42.66 |
| N1A 24207 | 24.00 | 20.00 | 7.00 | 21.00 | 18.50 | 14 | 4 | 21.88 | 15.00 | 2.50 | 1.06 | 0.31 | 6.04 | 1.50 | 50.56 |
| N1A 24247 | 24.00 | 24.00 | 7.00 | 21.00 | 22.50 | 12 | 4 | 21.88 | 19.00 | 2.50 | 1.06 | 0.31 | 6.01 | 1.50 | 66.53 |
| N1A 30207 | 30.00 | 20.00 | 7.00 | 26.00 | 18.50 | 12 | 6 | 27.50 | 12.75 | 3.63 | 1.25 | 0.44 | 8.01 | 2.00 | 66.52 |
| N1A 30247 | 30.00 | 24.00 | 7.00 | 26.00 | 22.50 | 12 | 6 | 27.50 | 16.75 | 3.63 | 1.25 | 0.44 | 8.01 | 2.00 | 79.94 |
| N1A 36247 | 36.00 | 24.00 | 7.00 | 32.00 | 22.50 | 12 | 6 | 33.50 | 16.75 | 3.63 | 1.25 | 0.44 | 8.01 | 2.00 | 93.94 |
| N1A 36307 | 36.00 | 30.00 | 7.00 | 32.00 | 28.50 | 12 | 8 | 33.50 | 22.75 | 3.63 | 1.25 | 0.44 | 8.01 | 2.00 | 113.80 |
| N1A 16129 | 16.00 | 12.00 | 9.00 | 13.00 | 10.50 | 14 | 4 | 13.88 | 7.00 | 2.50 | 1.06 | 0.31 | 8.04 | 1.50 | 27.36 |
| N1A 20169 | 20.00 | 16.00 | 9.00 | 17.00 | 14.50 | 14 | 4 | 17.88 | 11.00 | 2.50 | 1.06 | 0.31 | 8.04 | 1.50 | 31.06 |
| N1A 20209 | 20.00 | 20.00 | 9.00 | 17.00 | 18.50 | 14 | 4 | 17.88 | 15.00 | 2.50 | 1.06 | 0.31 | 8.04 | 1.50 | 47.35 |
| N1A 20249 | 20.00 | 24.00 | 9.00 | 17.00 | 22.50 | 14 | 4 | 17.88 | 19.00 | 2.50 | 1.06 | 0.31 | 8.04 | 1.50 | 54.84 |
| N1A 24209 | 24.00 | 20.00 | 9.00 | 21.00 | 18.50 | 14 | 4 | 21.88 | 15.00 | 2.50 | 1.06 | 0.31 | 8.04 | 1.50 | 54.91 |
| N1A 24249 | 24.00 | 24.00 | 9.00 | 21.00 | 22.50 | 12 | 4 | 21.88 | 19.00 | 2.50 | 1.06 | 0.31 | 8.01 | 1.50 | 124.69 |
| N1A 30209 | 30.00 | 20.00 | 9.00 | 26.00 | 18.50 | 12 | 6 | 27.50 | 12.75 | 3.63 | 1.25 | 0.44 | 8.01 | 2.00 | 71.61 |
| N1A 30249 | 30.00 | 24.00 | 9.00 | 26.00 | 22.50 | 12 | 6 | 27.50 | 16.75 | 3.63 | 1.25 | 0.44 | 8.01 | 2.00 | 85.23 |
| N1A 30309 | 30.00 | 30.00 | 9.00 | 26.00 | 28.50 | 12 | 8 | 27.50 | 22.75 | 3.63 | 1.25 | 0.44 | 8.01 | 2.00 | 101.83 |
| N1A 36249 | 36.00 | 24.00 | 9.00 | 32.00 | 22.50 | 12 | 6 | 33.50 | 16.75 | 3.63 | 1.25 | 0.44 | 8.01 | 2.00 | 107.19 |
| N1A 36309 | 36.00 | 30.00 | 9.00 | 32.00 | 28.50 | 12 | 8 | 33.50 | 22.75 | 3.63 | 1.25 | 0.44 | 8.01 | 2.00 | 120.03 |
| N1A 42249 | 42.00 | 24.00 | 9.00 | 38.00 | 22.50 | 12 | 6 | 39.50 | 16.75 | 3.63 | 1.25 | 0.44 | 8.01 | 2.00 | 111.14 |
| N1A 242012 | 24.00 | 20.00 | 12.00 | 21.00 | 18.50 | 14 | 4 | 21.88 | 15.00 | 2.50 | 1.06 | 0.31 | 11.04 | 1.50 | 61.27 |
| N1A 242412 | 24.00 | 24.00 | 12.00 | 21.00 | 22.50 | 12 | 4 | 21.88 | 19.00 | 2.50 | 1.06 | 0.31 | 11.01 | 1.50 | 131.91 |
| N1A 302012 | 30.00 | 24.00 | 12.00 | 26.00 | 22.50 | 12 | 6 | 27.50 | 16.75 | 3.63 | 1.25 | 0.44 | 11.01 | 2.00 | 93.66 |
| N1A 362012 | 36.00 | 30.00 | 12.00 | 32.00 | 28.50 | 12 | 8 | 33.50 | 22.75 | 3.63 | 1.25 | 0.44 | 11.01 | 2.00 | 129.27 |
| N1A 423612 | 42.00 | 30.00 | 12.00 | 39.00 | 28.50 | 12 | 6 | 39.50 | 22.75 | 3.63 | 1.25 | 0.44 | 11.01 | 2.00 | 144.36 |
| N1A 423612 | 42.00 | 36.00 | 12.00 | 38.00 | 34.50 | 12 | 8 | 39.50 | 28.75 | 3.63 | 1.25 | 0.44 | 11.01 | 2.00 | 168.84 |
| N1A 483612 | 48.00 | 36.00 | 12.00 | 44.00 | 34.50 | 12 | 8 | 45.50 | 28.75 | 3.63 | 1.25 | 0.44 | 11.01 | 2.00 | 197.18 |

dimensions in inches © UL 50 listed Type 1 * Formed panels

Series TA — air/oil tanks

The Lin-Act air/oil system gives you that smooth control hydraulic systems are known for, without conventional hydraulic apparatus — pump, motor, filter, pressure relief and control valves. All it takes is shop air, which means low initial cost and low maintenance for you.

A typical air-oil circuit is shown at right.

You can make the circuit self-bleeding by simply mounting the air/oil tanks above the cylinder. The tanks can be installed wherever convenient, either on or off the machine containing the cylinder. Plus, Lin-Act Series TA tanks come in a wide range of sizes for almost every volume requirement.

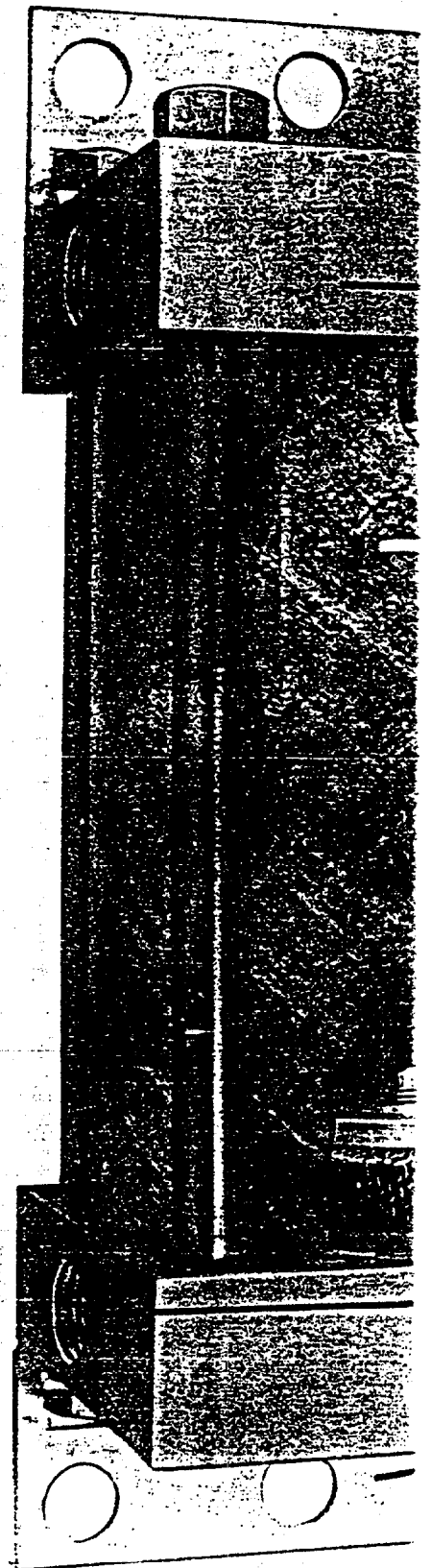
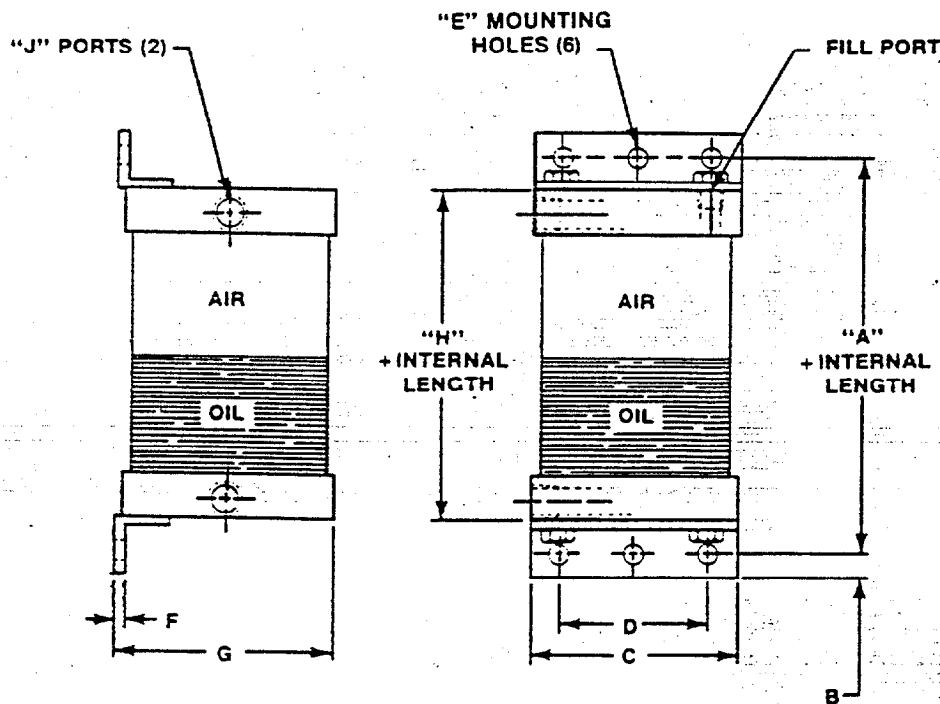

| TABLE A — TANK DIMENSIONS (inches) | | | | | | | | | |
|------------------------------------|----|--------------------------------|----|----|-------|------|---------------------------------|----|-----|
| BORE | A | B | C | D | E | F | G | H | J |
| 2½ | 4 | ¾ | 3 | 2¼ | 7/16 | ¼ | 3½ | 2 | ¼ |
| 3¼ | 5 | ½ | 3¾ | 2¾ | 9/16 | 3/16 | 3 ¹⁵ / ₁₆ | 2½ | 3/8 |
| 4 | 5 | ½ | 4½ | 3½ | 9/16 | 3/16 | 4¾ | 2½ | 3/8 |
| 5 | 5¾ | ¾ | 5½ | 4¼ | 11/16 | 3/16 | 5¾ | 3 | 3/8 |
| 6 | 5¾ | ¾ | 6½ | 5¼ | 13/16 | ¼ | 6½ | 3 | ½ |
| 8 | 6¾ | 1 ¹ / ₁₆ | 8½ | 7½ | 13/16 | ¼ | 8½ | 3 | ½ |

Pressures up to 200 PSI Air

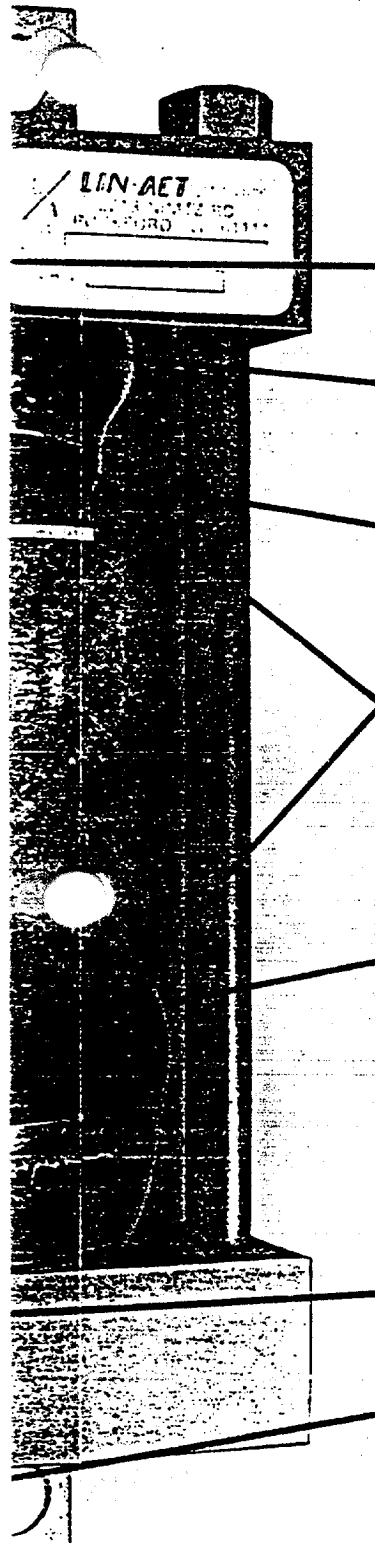

Series TA tank features:

Caps of anodized aluminum alloy, a lightweight material that resists corrosion.

Tube end seals for a positive long-lasting compression seal.

Pre-stressed steel tie rods eliminate fatigue failures, and provide maximum holding power for pressure-tight tube end sealing.

Internal baffles are the heart of an air-oil system. Lin-Act's unique baffle design eliminates oil agitation during cycling providing a smooth, bubble-free flow of oil to the cylinder for maximum control.

Unique fiberglass tube eliminates the need for a sight gauge — oil level is visible through the translucent fiberglass. Fiberglass also provides high strength, and won't shatter like acrylic. Design is more compact without external sight gauge and less prone to damage.

Full area ports provide quick bleeding, smoother action.

Angle mount brackets give you the greatest mounting flexibility.

Sizing your air/oil tank

1. Determine the cylinder volume by multiplying the square inches of piston area by the inches of stroke. See Table B.
2. Find the volumes closest to your volume requirement in Table C. Tanks of smaller diameters and greater lengths are generally less expensive than large diameter, shorter tanks of equal volume.
3. When ordering, specify bore and internal length required. Example: TA 5" bore x 10" internal length.

TYPICAL AIR-OIL CIRCUIT

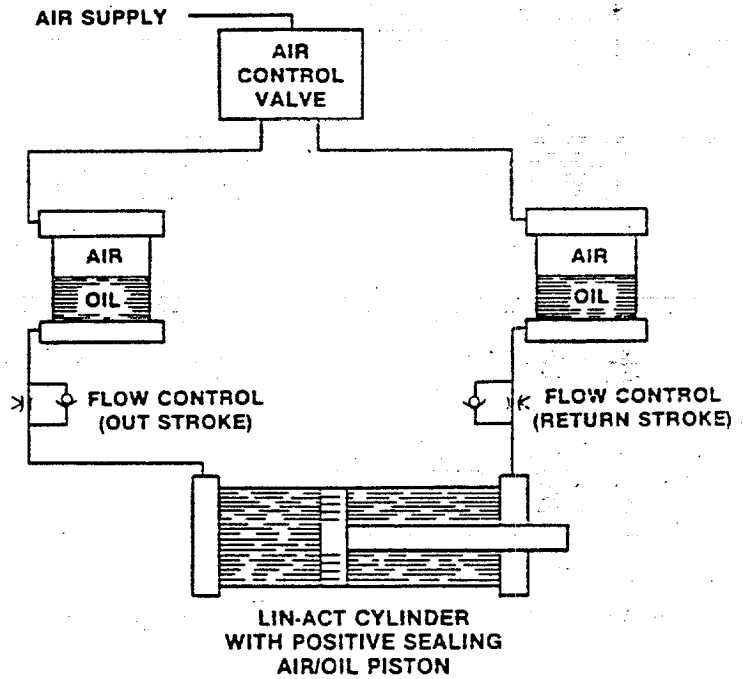

| CYLINDER BORE (In.) | PISTON AREA (Sq. In.) |
|---------------------|-----------------------|
| 1½ | 1.77 |
| 2 | 3.14 |
| 2½ | 4.91 |
| 3¼ | 8.30 |
| 4 | 12.57 |
| 5 | 19.64 |
| 6 | 28.27 |
| 8 | 50.27 |

| | | INTERNAL LENGTH OF TANK | | | | | | | | | | | |
|------|-------|-------------------------|------|------|------|-----|-----|-----|-----|-----|-----|-----|--|
| BORE | AREA | 5 | 6 | 7 | 8 | 9 | 10 | 12 | 14 | 16 | 18 | 20 | |
| 2½ | 4.91 | 12 | 16.6 | 21.6 | 25.5 | 30 | 34 | 43 | 52 | 61 | 70 | 78 | |
| 3¼ | 8.30 | 19 | 26 | 34 | 41 | 49 | 56 | 74 | 86 | 101 | 116 | 131 | |
| 4 | 12.57 | 28 | 40 | 51 | 62 | 74 | 85 | 107 | 129 | 153 | 175 | 195 | |
| 5 | 19.64 | 39 | 57 | 75 | 92 | 110 | 128 | 163 | 199 | 234 | 269 | 305 | |
| 6 | 28.27 | 62 | 86 | 111 | 137 | 161 | 186 | 232 | 284 | 333 | 386 | 432 | |
| 8 | 50.27 | 109 | 146 | 195 | 239 | 280 | 324 | 414 | 504 | 592 | 684 | 774 | |

General Purpose Filters

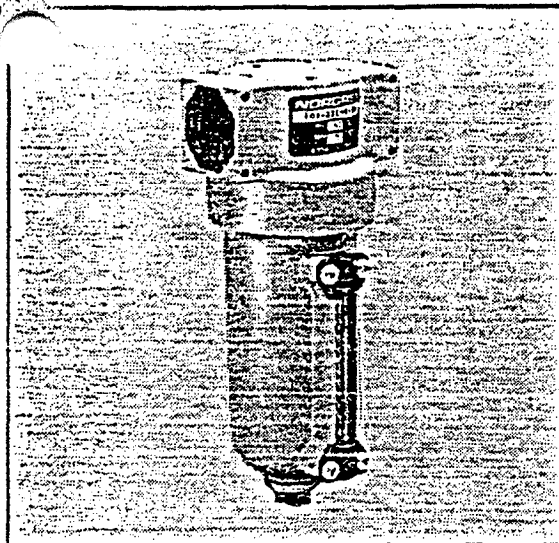

NORGREN F08 Series General Purpose Filters are used in compressed air systems to remove liquids and solid particles from the compressed air. **Standard filters listed in the following table include a 50-micron filter element and PTF port threads.** Optional features include a 5-micron element, ISO G threads, a 3-ounce polycarbonate bowl, and a service life indicator that turns from green to red when the filter element needs to be cleaned or replaced. Filters with an automatic drain should be used if the filter will be installed in an inaccessible area and when large quantities of water are present. Water vapor will pass thru the filter and could condense into liquid form downstream as air temperature drops. Install a NORGREN air dryer if water condensation could have a detrimental effect on the application.

Ordering Information - Standard Filters

| Port Size PTF | Flow* scfm (dm ³ /s) | Filter Element Rating (Micron) | MODEL NUMBERS | | | |
|------------------|------------------------------------|--------------------------------------|-----------------------------------|--------------------------------------|-----------------------------------|--------------------------------------|
| | | | Automatic Drain | | Manual Drain | |
| | | | Metal Bowl With Sight Glass | Transparent Polycarbonate Bowl | Metal Bowl With Sight Glass | Transparent Polycarbonate Bowl |
| 1/4 | 50 (24) | 50 | F08-200-A3DA | F08-200-A3TA | F08-200-M3DA | F08-200-M3TA |
| 3/8 | 65 (31) | 50 | F08-300-A3DA | F08-300-A3TA | F08-300-M3DA | F08-300-M3TA |
| 1/2 | 70 (33) | 50 | F08-400-A3DA | F08-400-A3TA | F08-400-M3DA | F08-400-M3TA |
| 3/4 | 70 (33) | 50 | F08-000-A3DO | F08-000-A3TO | F08-000-M3DO | F08-000-M3TO |

*Approximate flow at 100 psig (6.9 bar) inlet pressure and 5 psid (.3 bar) pressure drop.
 **Body is cored to accept separate port inserts. See page 23.

Options

To order filters with optional features, note the filter model number that comes closest to the desired filter from the preceding order table. Change the model number as shown in the following diagram to obtain the desired option.

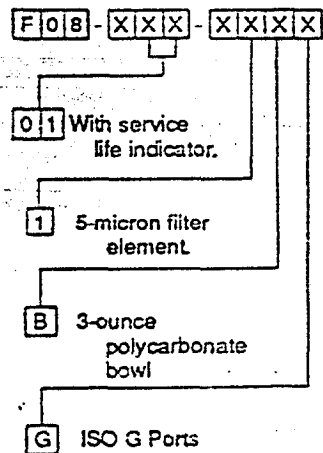

Repair Kits

- 5-Micron Element: 3161-16
- 50-Micron Element: 3161-18
- Automatic Drain: 3000-10
- Seals and Gaskets: 3163-05
- Metal Bowl Sight Glass: 2273-20

Specifications

Fluid: Compressed Air
 Maximum Inlet Pressure:
 Transparent Bowl: 150 psig (10.3 bar)
 Metal Bowl: 250 psig (17.2 bar)
 Maximum Temperature:
 Transparent Bowl: 125°F (52°C)
 Metal Bowl: 175°F (79°C)
 Automatic Drain:
 Connection: 1/8" NPTF
 Minimum Operating Pressure: 10 psig (.69 bar). The drain is open when the filter is not pressurized and closes when the bowl is pressurized to approximately 5 psig.

Materials of Construction

Body: Zinc
 Bowl:
 Transparent: Polycarbonate Plastic
 Metal: Zinc
 Metal Bowl Sight Glass: Pyrex
 Elastomers: Neoprene and Nitrile
 Filter Element: Porous Polypropylene

Graphic Symbols

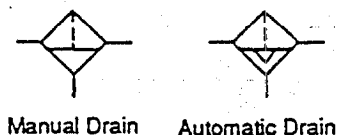

Dimensions

All Dimensions in Inches (mm).

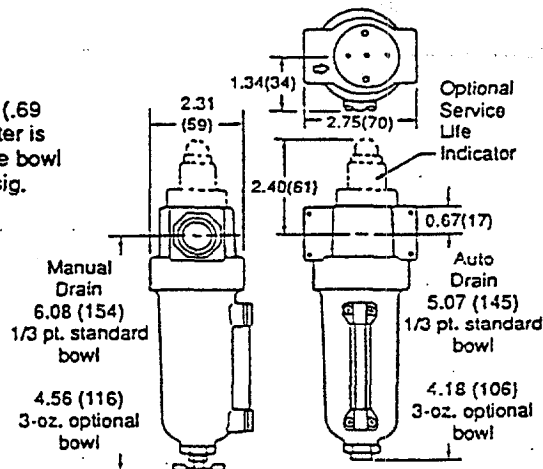

Accessories (Also see page 24)
 Mounting bracket: 3783-52

F08 General Purpose Filters
For Compressed Air Service
Installation & Maintenance Instructions

NIP-135
 December 1989
 Supersedes January 1989

SPECIFICATIONS

Fluid: Compressed Air
 Maximum Inlet Pressure:
 Transparent Bowl: 150 psig (10.3 bar)
 Metal Bowl: 250 psig (17.2 bar)
 Maximum Temperature:
 Transparent Bowl: 125°F (52°C)
 Metal Bowl: 175°F (79°C)
 Filter Bowl: Metal with sight glass. Transparent bowl is optional.
 Port Size: 1/4", 3/8", or 1/2" PTF. ISO G threads are optional. Port threads are tapped directly into the body casting or are provided by steel inserts pinned in place.
 Filter Element: 50-micron. 5-micron is optional.
 Drain: Automatic or Manual.
 Automatic Drain Connection: 1/8" NPTF female
 Automatic Drain Minimum Operating Pressure: 10 psig (0.69 bar).
 The drain is open when the filter is not pressurized and closed when the bowl is pressurized to approximately 5 psig.
 Color Code for Optional Service Life Indicator:
 Green: Pressure drop less than 6 psid (.4 bar)
 Green & Red: Pressure drop between 6 and 15 psid (.4 and 1 bar)
 Red: Pressure drop greater than 15 psid (1 bar)

MATERIALS OF CONSTRUCTION

Body: Zinc
 Bowl:
 Transparent: Polycarbonate Plastic
 Metal: Zinc
 Metal Bowl Sight Glass: Pyrex
 Elastomers: Neoprene and Nitrile
 Filter Element: Porous Polypropylene
 Optional Service Life Indicator:
 Body: Aluminum
 Lens: Polycarbonate
 Internal Parts: Stainless Steel, ABS and Acetal
 Diaphragm: Nitrile

INSTALLATION

NOTE

These filters will remove most liquid and solid particles from the compressed air. Water vapor, however, will pass through these filters and could condense into liquid form downstream as air temperature drops. Install an air dryer if water condensation could have a detrimental effect on the application.

1. Air line piping should be same size as filter ports.
2. Install filter vertically (drain at bottom) in air line. Locate filter upstream of regulators and lubricators and as near as possible to the application point.
3. Air flow must be in direction of arrow on body. Connect piping to proper ports using pipe thread sealant on male threads only. Do not allow sealant to enter interior of filter.
4. Automatic drains are ported 1/8" NPTF to allow piping away of expelled liquid. Use flexible tubing or nonrigid piping with a 1/8" minimum I.D. for the drain line. Avoid restrictions in the drain line.
5. Before applying air pressure, be sure bowl is hand tight. See step 6 of *Reassembly* on next page.

SERVICING

1. Filters with manual drain must be drained as frequently as necessary to keep liquid level below baffle. If liquid level rises above baffle, liquid will be carried downstream.
2. Clean or replace filter element when it becomes plugged or dirty, or when optional pressure drop indicator shows approximately one-half red/green.

GRAPHIC SYMBOLS



Manual Drain

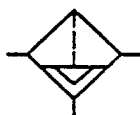

Automatic Drain

DIMENSIONS - ALL DIMENSIONS IN INCHES (MM)

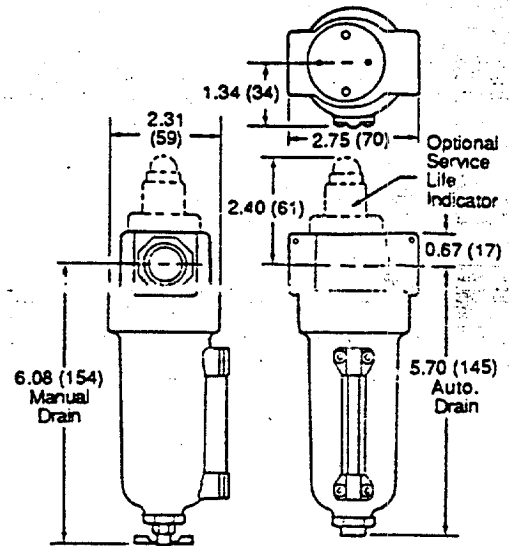

WARNING

These products are intended for use in industrial compressed air systems. Do not use these products where pressures and temperatures can exceed those listed under *Specifications*.
 The polycarbonate plastic bowl used on the filter can be damaged and possibly burst if exposed to such substances as certain solvents, strong alkalis, compressor oils containing ester-based additives or synthetic oils. Fumes of these substances in contact with the polycarbonate bowl, externally or internally, can also result in damage. Clean with warm water only.

Use metal bowl in applications where a plastic bowl might be exposed to substances that are incompatible with polycarbonate.

Do not use filters with the service life indicator where the lens might be exposed internally or externally to substances incompatible with polycarbonate.

Before using these products with fluids other than air, for nonindustrial applications, or for life-support systems consult NORGREN.

LIMITED WARRANTY, DISCLAIMER & LIMITATION OF REMEDIES

Items sold by NORGREN are warranted to be free from defects in materials and workmanship for a period of one year from the date of manufacture, provided said items are used according to NORGREN'S recommended usages. NORGREN'S liability is limited to the repair of, refund of purchase price paid for, or replacement in kind of, at NORGREN'S sole option, any items proved defective, provided the allegedly defective items are returned to NORGREN prepaid. The warranties expressed above are in lieu of and exclusive of all other warranties.

There are no other warranties, expressed or implied, except as stated herein. There are no implied warranties of merchantability or fitness for a particular purpose, which are specifically disclaimed. NORGREN'S liability for breach of warranty as herein stated is the exclusive remedy, and in no event shall NORGREN be liable or responsible for incidental or consequential damages, even if the possibility of such incidental or consequential damages has been made known to NORGREN.

NORGREN reserves the right to discontinue manufacture of any product or change product materials, design, or specifications without notice.



NORGREN

©1989 NORGREN

DISASSEMBLY

1. Shut off inlet pressure and reduce pressure in filter to zero. Filter can be disassembled without removal from air line.
2. Remove bowl (11 or 12) by turning counterclockwise. The automatic drain (18 & 19) is not repairable and should be replaced if nonoperative. Remove petcock (14) only if replacement is required.
3. Remove baffle (25) by turning counterclockwise, then remove element (26), louver (27), and o-ring (28).
4. Remove screws (2), then remove optional service life indicator (1).

CLEANING

1. Clean polycarbonate bowl (11) and lens on service life indicator (3) with warm water only. Clean other parts using warm water and soap.
2. Dry parts and blow out internal passages in body (10) using clean, dry compressed air. Blow air through filter element (26) from inside to outside. Replace element when plugged.
3. Inspect parts and replace those found to be damaged.

REASSEMBLY

1. Lubricate o-rings (13, 24, 28) and the upper surface of the diaphragm (5) with a wipe coat of good quality o-ring grease.
2. During reassembly of the optional service life indicator, insert diaphragm (5) and support ring (6) into indicator body (3) with the rounded end of support ring toward diaphragm. Place o-rings (4, 6, 9) in their respective seats, then attach indicator (3) and adapter (7) to body (10). Arrows on the service life indicator (3) and filter body (10) must point in the same direction. Tighten screws (2) to 25- to 35 inch-pounds.
3. Assemble the filter as shown on the exploded view. Place o-ring (28) on louver (27), then press into place into body (10). Screw baffle (25) into filter body (10) until contact is made with the filter element (26), then tighten an additional 1/4 turn.
4. Tighten drain retaining nut (15 or 17) to 20- to 25 inch-pounds. Tighten manual drain petcock (14) to 15- to 20 inch pounds.
5. Assemble the sight glass components (items 20 thru 24) to the metal bowl, then apply a 2- to 4 pound clamping force to the upper and lower sight glass brackets (21) to pull the brackets together and tighten the four attaching screws (20).
6. If installing a metal bowl with sight glass, first position the bowl in the body with the sight glass facing the front or back of the filter, then tighten the bowl into the body hand tight (approximately two full turns). The sight glass will be positioned at the starting point after two full turns.

REPAIR PARTS & KITS (Kits are universal and may contain parts not used on your filter. Always replace used parts with identical parts from the kit. Discard kit parts not used on your filter).

Seal & Gasket Kit (items 13, 19 & 28): 3163-05

Service Life Indicator Kit (items 2 thru 6): 5796-50

Metal Bowl Sight Glass Kit (items 13, 20, 22, 23, 24): 2273-20

Automatic Drain (items 18 & 19): 3000-10

5-micron filter element (item 26): 3161-16

25-micron element (item 26): 3161-17

50-micron filter element (item 26): 3161-18

Metal Bowl & Manual Drain (items 12 thru 16, 19 thru 24): 3777-50

Metal Bowl & Automatic Drain (items 12, 13, 17 thru 24): 3777-51

Transparent Bowl & Manual Drain (items 11, 13 thru 16, 19): 3776-50

Transparent Bowl & Auto. Drain (items 11, 13, 17, 18, 19): 3776-51

ACCESSORIES

Service Life Indicator Conversion Kit (item 1): 5796-40

Punch out two 0.078 diameter holes in top of body and remove any dirt or metal shavings from the body before assembling filter.

Assemble the service life indicator to the filter body as described in step 2 of *Reassembly*.

Wall Mounting Bracket: 3783-52

Dimensions in inches (mm).

A = 2.40 (61)

B = 1.00 (25)

C = 1.50 (38)

D = 0.25 (6)

E = 3.56 (90)

Use 1/4" bolts to mount bracket to wall.

Distance from wall to centerline of ports is approximately 1.50" (38mm).

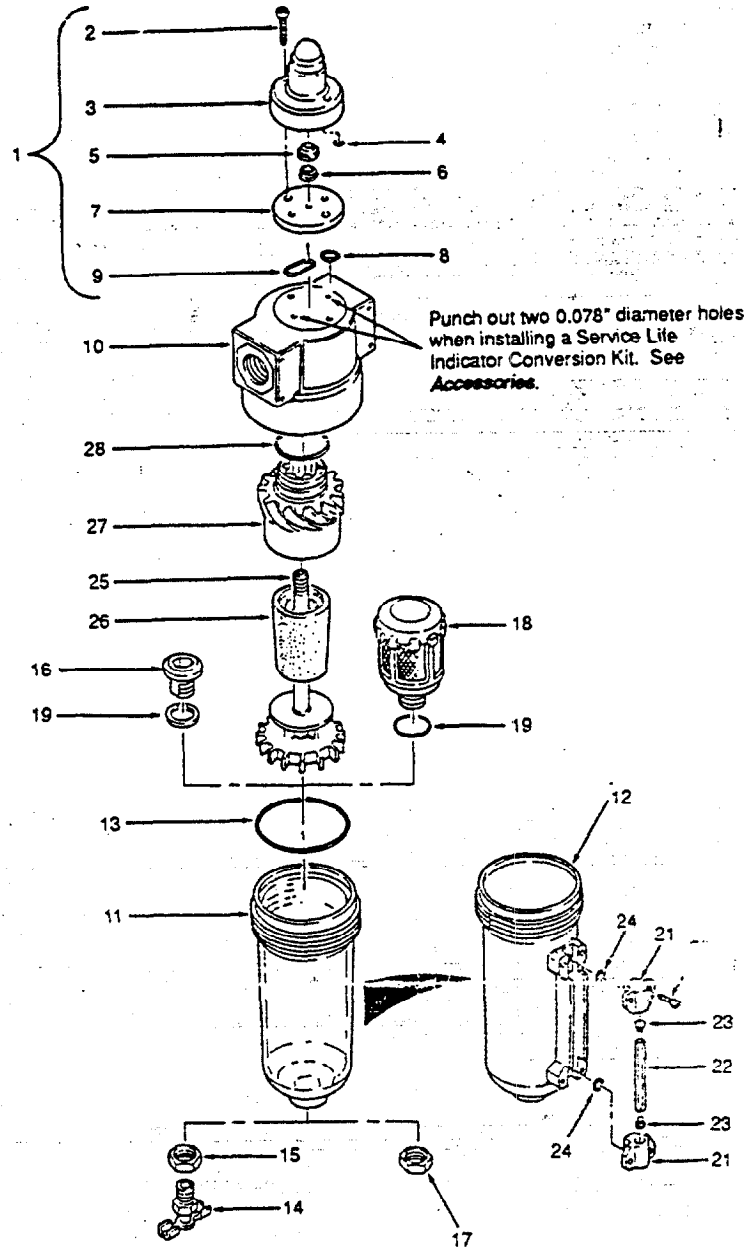
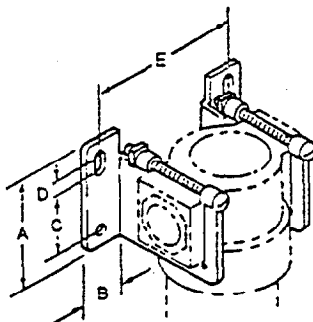

PARTS LIST FOR EXPLODED VIEW

- | | |
|--|---------------------|
| 1. Optional service life indicator & adapter | 15. Nut |
| 2. Screw | 16. Insert & gasket |
| 3. Indicator | 17. Nut |
| 4. O-ring | 18. Automatic drain |
| 5. Diaphragm | 19. Gasket |
| 6. Support ring | 20. Screw |
| 7. Adapter | 21. Bracket |
| 8. O-ring | 22. Sight glass |
| 9. O-ring | 23. Seal |
| 10. Body | 24. O-ring |
| 11. Transparent bowl | 25. Baffle |
| 12. Metal bowl | 26. Element |
| 13. O-ring | 27. Louver |
| 14. Drain petcock | 28. O-ring |



NORGREN

5400 South Delaware St
PHONE 303/794-2611
FAX 303/795-9487
PRINTED IN U.S.A.

Littleton, CO 80120-1663
INTEL TEL 4322030

IMI

Pressure Regulators

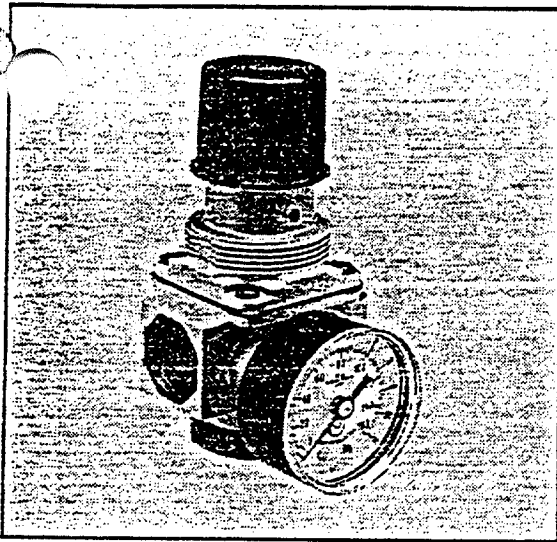

NORGREN R08 Pressure Regulators are used in compressed air systems to reduce system pressure to levels which can be used to operate air tools and other air operated devices, and to maintain the reduced pressure despite changes in the inlet pressure and changes in downstream flow requirements. *Standard regulators listed in the following table are relieving regulators with a pressure gauge and PTF threads.* Options include nonrelieving regulators, regulators without gauge, and ISO G threads. Relieving regulators allow the outlet pressure to be reduced even though the system is dead-ended.

Ordering Information - Standard Regulators

| Port Size PTF | MODEL NUMBERS | | |
|------------------|----------------------------------|--|-------------------------------------|
| | 5 to 60 psig (0.3 to 4.1 bar) | Outlet Pressure Adjustment Ranges* 5 to 150 psig (0.3 to 10.4 bar) | 10 to 250 psig (0.7 to 17.2 bar) |
| • 1/4 | R08-200-RGFA | • R08-200-RGMA | R08-200-RGSA |
| • 3/8 | R08-300-RGFA | R08-300-RGMA | R08-300-RGSA |
| • 1/2 | R08-400-RGFA | R08-400-RGMA | R08-400-RGSA |
| No Threads** | R08-000-RGFO | R08-000-RGMO | R08-000-RGSO |

* Pressure adjustment ranges are not minimum or maximum outlet pressure limits. Regulators can be adjusted to zero psig outlet pressure and, generally, to pressures in excess of those specified. The use of these regulators to control pressures outside of the specified ranges is not recommended.
** If the regulator is cored to accept separate port inserts. See page 23.

Options

To order regulators with optional features, note the regulator model number that comes closest to the desired regulator from the preceding order table. Change the model number as shown in the following diagram to obtain the desired option.

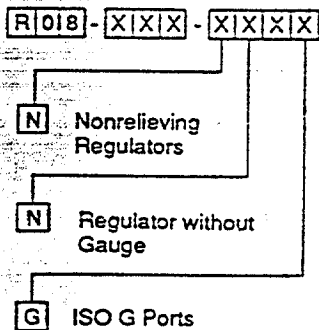

Repair Kits

Relieving Regulators: 5298-14
Nonrelieving Regulators: 5298-13

Specifications

Fluid: Compressed Air
Maximum Inlet Pressure: 300 psig (20.7 bar)
Temperature Range: 0 to 175°F (-18° to 66°C)
with dewpoint less than air temperature
below 35°F (2°C)
Gauge Ports: 1/4 PTF

Materials of Construction

Body, Bonnet, Valve Seat: Zinc
Valve: Brass
Elastomers: Nitrile
Bottom Plug: Acetal

Accessories (Also see page 24)

Wall mounting bracket and metal panel nut: 5203-06
Metal panel nut: 5191-88
Plastic panel nit: 5191-89
Tamper resistant wire kit for adjusting knob: 2117-02
Gauges (2" dial; 1/4" PTF back mount):

| psig | Range (bar) | Model Number |
|----------|-------------|--------------|
| 0 to 60 | (0 to 4) | 18-013-208 |
| 0 to 160 | (0 to 11) | 18-013-209 |
| 0 to 300 | (0 to 20) | 18-013-210 |

Graphic Symbol

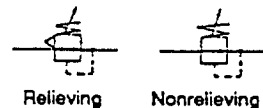

Dimensions

All dimensions in inches (mm).

Panel Mounting Hole: 1.89 (48) Dia.
Maximum Panel Thickness: 0.19 (5)

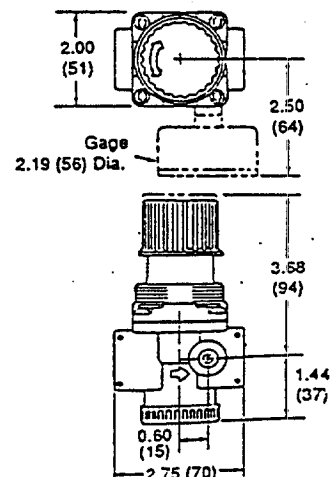

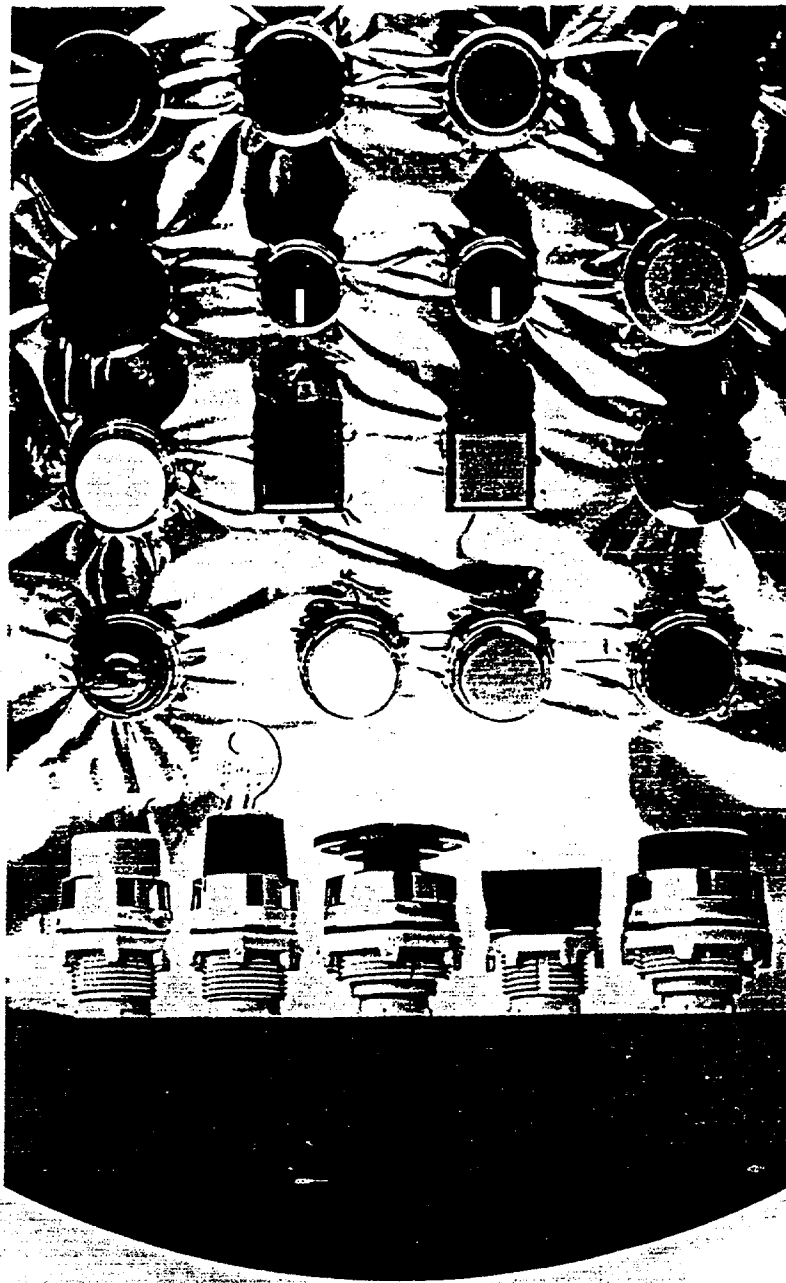

Minimatic Push Buttons

*Clippard
Minimatic®*

Clippard Pushbutton Actuators Mounting Methods and Data

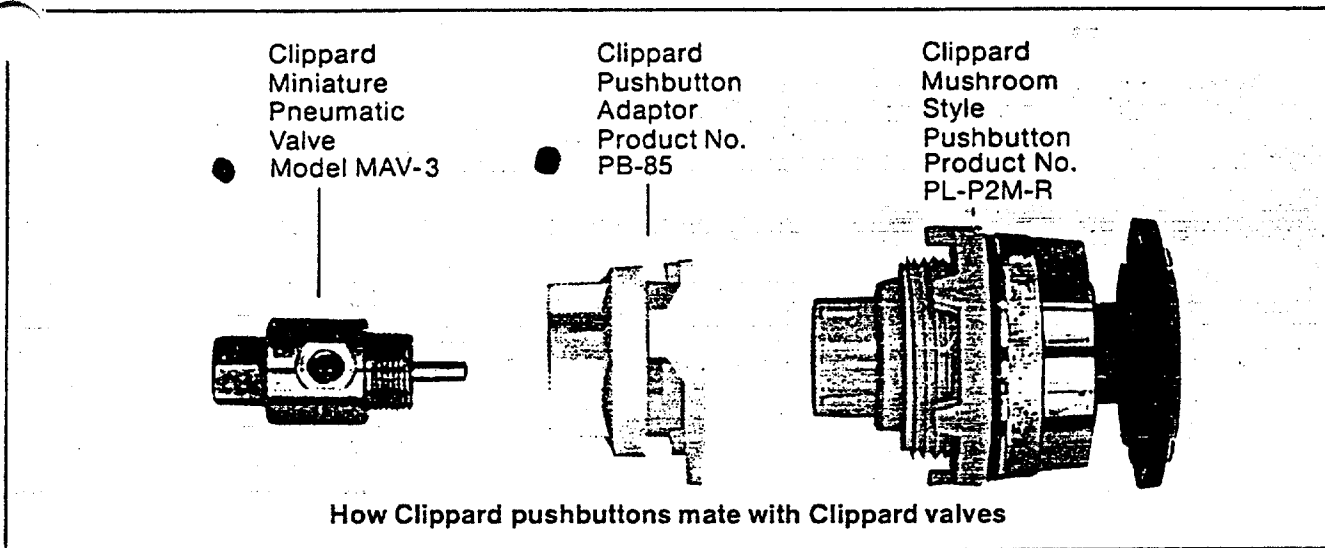

To assemble: Remove nut from pushbutton. Insert pushbutton with rubber gasket through drilled hole in mounting panel. Put mounting nut back on pushbutton. Tighten to panel using Wrench (PB-60). The rear section of each pushbutton has four flanges arranged around its outside diameter. They guide the adaptor into the proper position, and provide the mechanism for locking the adaptor to the pushbutton. Thread valve into adaptor and tighten.

Proper valve spacing should be used (see chart). Wrench flats provided on adaptor. Valve and adaptor, complete with necessary fittings, should be assembled prior to mounting on rear of pushbuttons. Mount adaptor on back of pushbutton (lever end toward pushbutton). The adaptor and valve may be oriented in any one of four positions for your convenience. Lock in place using locking lever.

Mounting Clippard Pushbuttons

Mounting Method

Size 22—Typical drill plan
drill plan for units fitted with optional anti-rotation ring

1.8" min.
1.3" min.
.875"
.125"
.437"
.875"

* > 1.8" for Ø40 mushroom head buttons and non-rectangular nameplates
* > 1.77" for lever handles
* > 1.9" for twin-touch with vinyl shroud

Size 30—Typical drill plan
drill plan for units fitted with optional anti-rotation ring

1.97" min.
1.58" min.
1.2"
.125"
.60"
1.20"

** 1.77" without nameplates
* > 1.58" for mushroom head buttons Ø 40
* > 2.75" for mushroom head buttons Ø 70
* > 1.96" for lever handles
* > 2.75" for mushroom head buttons Ø 70

groove at the top



4 3 2 1 (3) optional anti-rotation ring

ensure that the collar is screwed fully onto the head (1) fit the sealing ring (2) and push the head through the panel positioning the groove at the top. if required fit the optional anti-rotation ring (3) tighten the nut (4) by hand or by using the fixing tool (6).

fit the electrical block (5) on the head and retain by rotating the locking lever to the ON position

NOTE: These suggestions are for mounting pushbuttons using 10-32 ported Clippard Minimatic Valves. If larger valves are used, close spacing might result in interference between 1/8 NPT fittings and piping. Check panel layout before drilling holes to assure proper clearances for larger components.

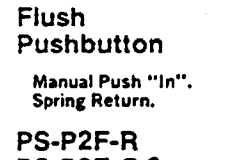
Size 22

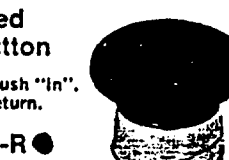
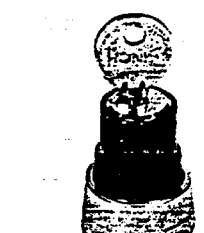
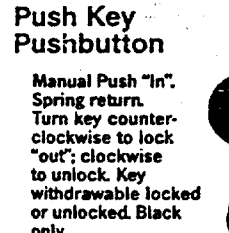
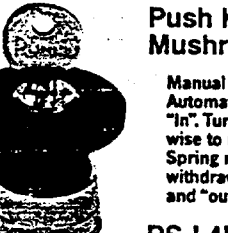
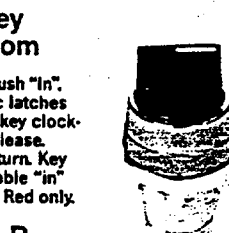
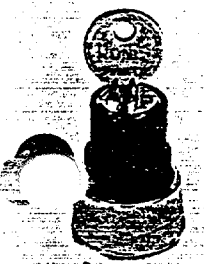
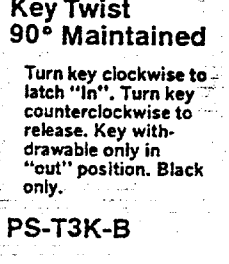
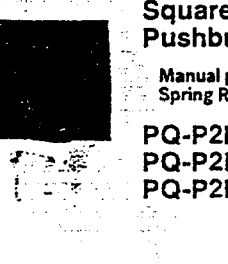
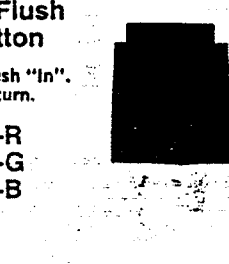
| | | | |
|---|---|---|---|
|  Flush Pushbutton Manual Push "In". Spring Return. PS-P2F-R PS-P2F-G PS-P2F-B PS-P2F-Y |  Extended Pushbutton Manual Push "In". Spring Return. PS-P2E-R PS-P2E-G PS-P2E-B PS-P2E-Y |  Manual Push Mushroom Manual Push "In". Spring Return. PS-P2M-R PS-P2M-G PS-P2M-B |  Automatic Push/Turn Mushroom Manual Push "In". Latches "In". Turn clockwise to unlatch. Spring return. PS-L3M-R PS-L3M-G PS-L3M-B |
|  Push Key Pushbutton Manual Push "In". Spring return. Turn key counterclockwise to lock "out"; clockwise to unlock. Key withdrawable locked or unlocked. Black only. PS-P4K-B |  Push Key Mushroom Manual Push "In". Automatic latches "In". Turn key clockwise to release. Spring return. Key withdrawable "in" and "out". Red only. PS-L4M-R |  Spring Return Twist 45° Turn clockwise and hold for "In". Release for spring return. Black only. PS-T2T-B |  Maintained Twist 90° Turn clockwise to latch "In". Turn counterclockwise to release. Black only. PS-T3T-B |
|  Key Twist 90° Maintained Turn key clockwise to latch "In". Turn key counterclockwise to release. Key withdrawable only in "out" position. Black only. PS-T3K-B |  Square Flush Pushbutton Manual push "In". Spring Return. PQ-P2F-R PQ-P2F-G PQ-P2F-B |  Square Extended Pushbutton Manual push "In". Spring Return. PQ-P2E-R PQ-P2E-G PQ-P2E-B |  Square Twist 90° Maintained Turn clockwise to latch "In". Turn counterclockwise to release. Black only. PQ-T3T-B |

CLIPPARD PRODUCT NUMBER CODING SYSTEM

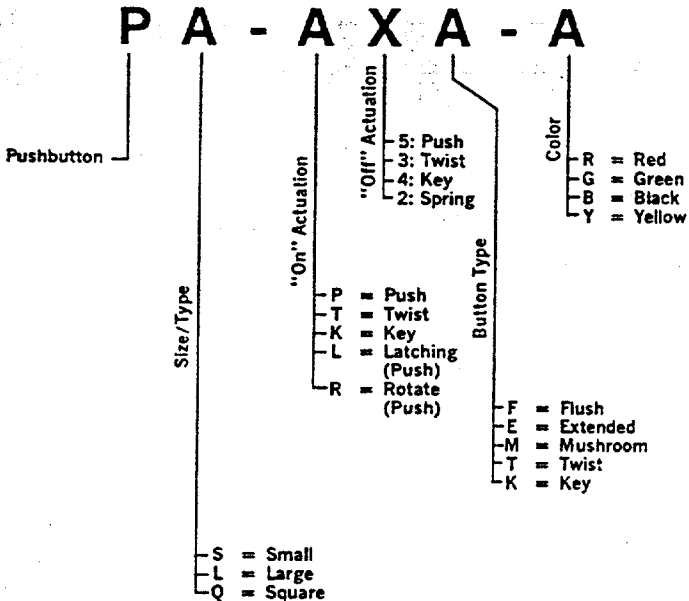

Actuator Mounting Chart

Following chart gives the necessary spacing required between the shoulder of the valve and the base of the adaptor.

| VALVES | PB-85 |
|----------------------|-------|
| MAV-2, -2P, -3, -3P | None |
| MAVO-2, -3 | None |
| MJV-2, -3 | 1/8" |
| MJVO-2, -3 | 1/8" |
| MAV-4, -4D | None |
| MJV-4, -4D | None |
| ES-1 | None |
| FV-3, -3P, -3D, -3DP | 1/8" |
| FV-4, -4P, -4D, -4DP | 1/8" |
| FV-5, -5P, -5D, -5DP | 1/8" |

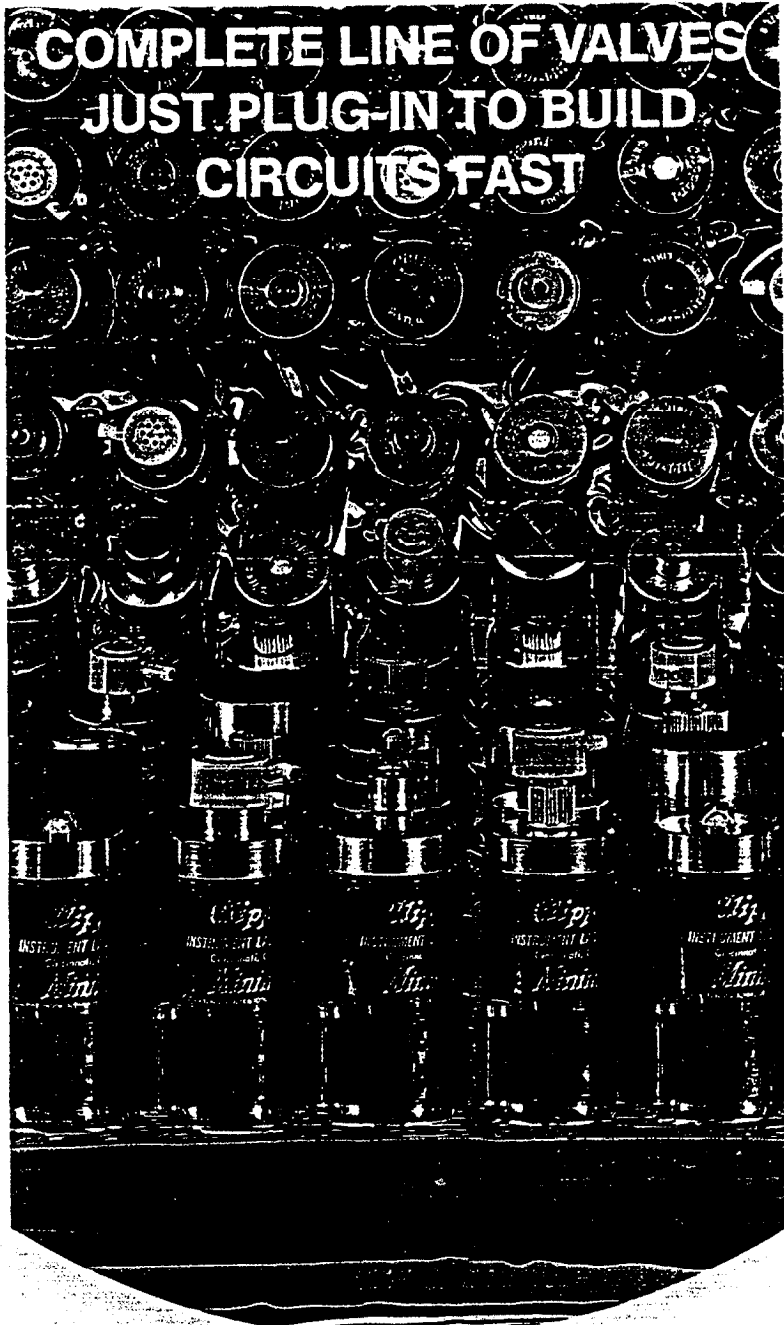

Minimatic Modular Components



Manifold Body

*Clippard
Minimatic®*

Exclusive Microgap construction for full air flow, long life and fast response.

Eight air passages extend longitudinally through the body surrounding the valve cavity.

Milled slots in valve cavity connect the valve through longitudinal passages to Octoport outlets.

Valves are of brass, stainless steel, and acetal copolymer.

Manifold body is molded of high density acetal copolymer. High dimensional stability, outstanding impact resistance, and excellent moisture, ultraviolet, and temperature characteristics.

Manifold sub-plate is tapped for standard 10-32 Clippard fittings with all piping located in neat patterns beneath modules.

All valves are fully ported for maximum versatility.

One of the major elements of the Clippard Minimatic Modular Controls is the manifold body. It encircles a central valve cavity with air passages that can be used at any point along the axis of the valve. These passages terminate at the base of the body in a circular Octoport pattern. The body mates with a manifold subplate which mounts the complete module and provides 10-32 tapped holes for standard hose fittings. A single molded Octoport gasket, held in place by the two mounting screws, insures a positive seal.

Because of the easy availability of an air connection wherever it is required, the manifold body permits valve elements to be designed for maximum perform-

ance without the restrictive limitations of rigid port configurations. It also allows multiple porting . . . using two or more ports as an inlet, outlet, supply, etc. This reduces the amount of external piping needed to complete the circuit. Furthermore the manifold body enables the internal interconnection of ports. This is especially valuable in a number of modules that contain more than one valve.

The separate elements are interconnected in the same module to provide complete subcircuits such as a three input "OR", three input "AND", or a two input "NOR". These functions further reduce external piping.

MODEL NUMBER

R-301

THREE WAY VALVES



DESCRIPTION:

R-301 is a 3-way, spring return, fully ported, piloted valve. It can be used normally-OPEN, normally-CLOSED, as a diverter or as a selector. It can also be used as a 2-way valve by plugging the exhaust ports.

PERFORMANCE:

| | |
|------------------------------|-------------|
| Flow (SCFM @ 100 psi) | 10 |
| Pilot Pressure (psi) Minimum | 40 |
| Temperature | 30 to 230°F |
| Working Pressure (psi) | 0 to 150 |
| Response Time (milliseconds) | 10 |

FEATURES:

- Indicator shows valve position
- Multiple porting speeds piping
- Micro Gap Construction—snap action and no blow by
- Balanced design allows speed control at exhausts

ANSI SYMBOL*

PORT USAGE**

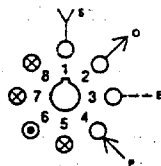
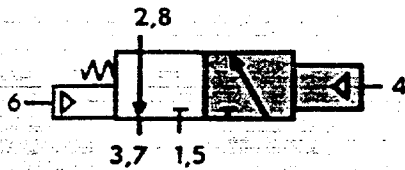

3-WAY NORMALLY CLOSED

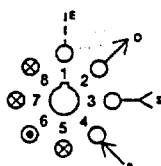
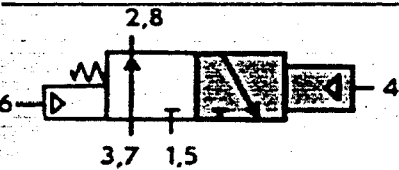

3-WAY NORMALLY OPEN

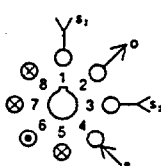
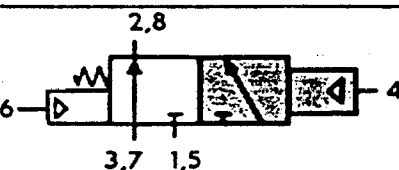

SELECTOR

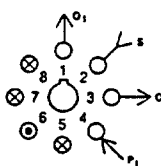
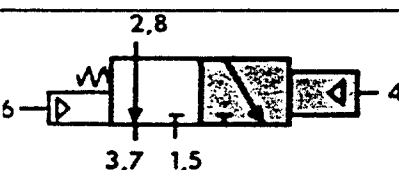

DIVERTER

* Shaded portion of symbol represents valve position when indicator is down (not visible).

MODEL NUMBER

R-302

THREE WAY VALVES

652471



DESCRIPTION:

R-302 is a 2-position, 3-way, double-piloted, fully ported valve. It can be used normally-OPEN, normally-CLOSED, as a 2-position diverter, as a 2-position selector, or as a 2-way valve by plugging the exhaust ports.

PERFORMANCE:

| | |
|------------------------------|-------------|
| Flow (SCFM @ 100 psi) | 10 |
| Pilot Pressure (psi) Minimum | 20 |
| Temperature | 30 to 230°F |
| Working Pressure (psi) | 0 to 150 |
| Response Time (milliseconds) | 10 |

FEATURES:

- Indicator shows valve position
- Multiple porting speeds piping
- Micro Gap Construction—snap action and no blow by
- Balanced design allows speed control at exhausts

ANSI SYMBOL*

PORT USAGE**

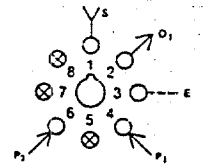
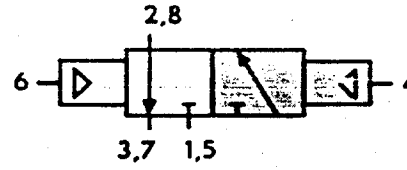

3-WAY TWO POSITION

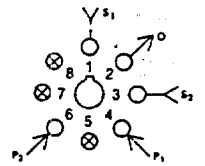
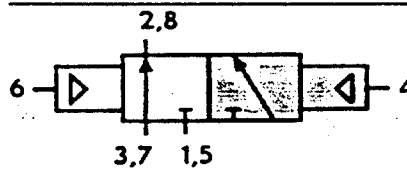

SELECTOR TWO POSITION

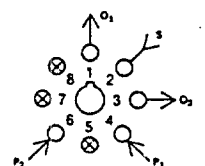
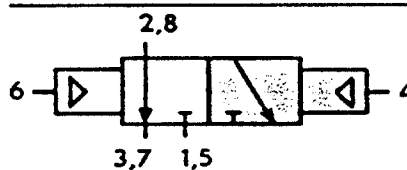

DIVERTER TWO POSITION

** See sheet D-05 for key to port usage notations.

MODEL NUMBER

652507

R-321

THREE WAY COMBINATION VALVES

DESCRIPTION:

R-321 is a 3-way, spring return, fully ported valve with an interconnected shuttle valve in one pilot line to provide 2 inputs to the pilot. It can be used normally-OPEN, normally-CLOSED, as a diverter, or as a selector. Auxiliary outlet is provided through port 7, which should be plugged if not used.



PERFORMANCE:

| | |
|------------------------------------|-------------|
| Flow (SCFM @ 100 psi) | 10 |
| Pilot Pressure (psi) Minimum | 40 |
| Temperature | 30 to 230°F |
| Working Pressure (psi)..... | 0 to 150 |
| Response Time (milliseconds)..... | 10 |

FEATURES:

- Indicator shows valve position
- Multiple porting speeds piping
- Micro Gap Construction—snap action and no blow by
- Balanced design allows speed control at exhausts

ANSI SYMBOL*

PORT USAGE**

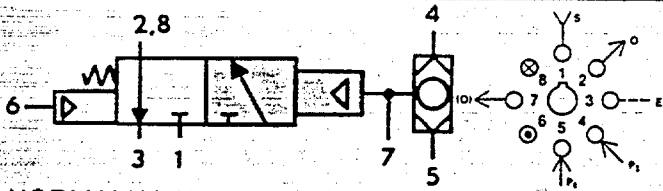

NORMALLY CLOSED

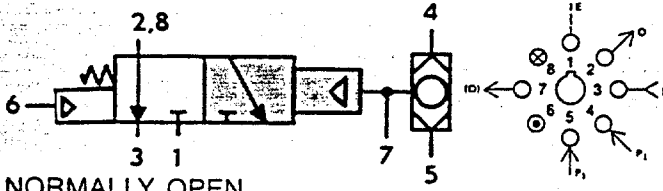

NORMALLY OPEN

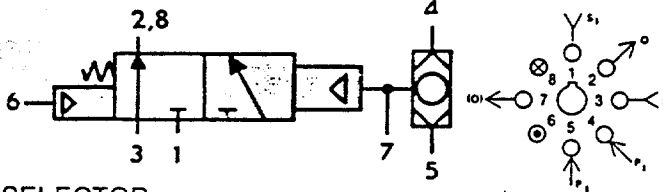

SELECTOR

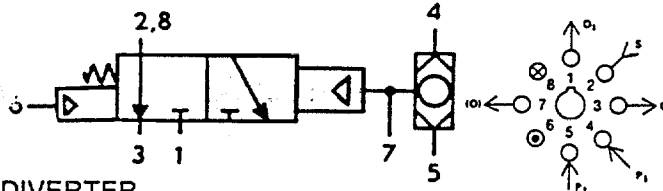

DIVERTER

* Shaded portion of symbol represents valve position when indicator is down (not visible).

MODEL NUMBER

R-322

THREE WAY COMBINATION VALVES

DESCRIPTION:

R-322 is a 3-way valve, 2-position, fully ported, with an interconnected shuttle valve in one pilot line to provide 2 inputs to the pilot. It can be used normally-OPEN, normally-CLOSED, as a 2-position selector, or as a 2-position diverter. Auxiliary outlet is provided through port 7, which should be plugged if not used.



PERFORMANCE:

| | |
|------------------------------------|-------------|
| Flow (SCFM @ 100 psi) | 10 |
| Pilot Pressure (psi) Minimum | 20 |
| Temperature | 30 to 230°F |
| Working Pressure (psi)..... | 0 to 150 |
| Response Time (milliseconds)..... | 10 |

FEATURES:

- Indicator shows valve position
- Multiple porting speeds piping
- Micro Gap Construction—snap action and no blow by
- Balanced design allows speed control at exhausts

ANSI SYMBOL*

PORT USAGE**

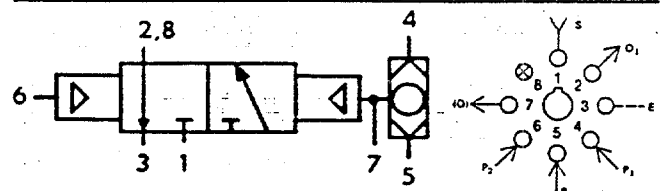

NORMALLY CLOSED

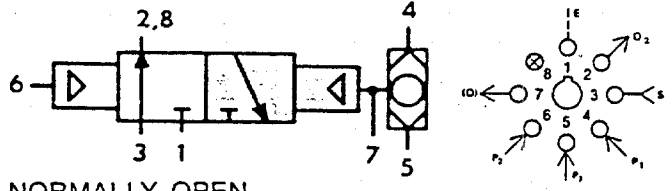

NORMALLY OPEN

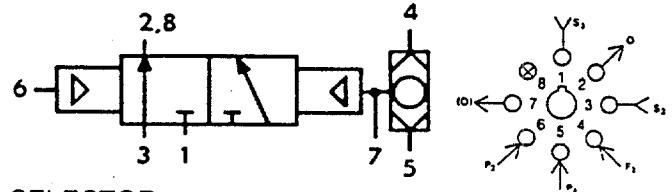

SELECTOR

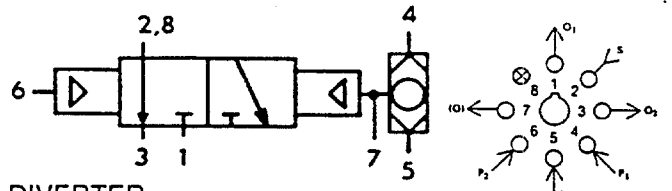

DIVERTER

** See sheet D-05 for key to port usage notations.

OMNI 375

Power and Control Air Valves in 1/4" & 3/8" NPTF

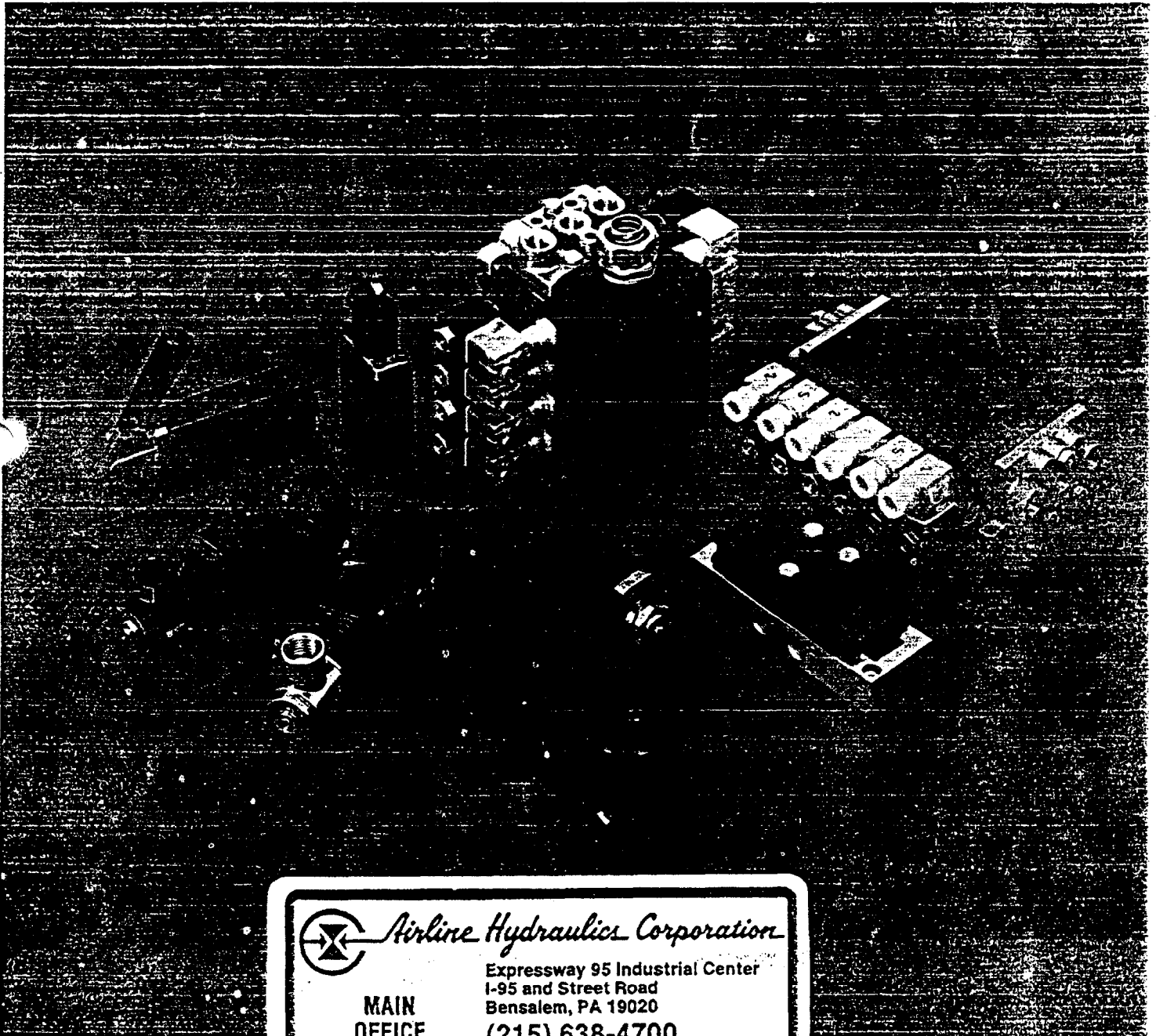

Airline Hydraulics Corporation

MAIN
OFFICE

Expressway 95 Industrial Center
I-95 and Street Road
Bensalem, PA 19020
(215) 638-4700
FAX (215) 638-1707



The ISI Companies

Contents

| | Page |
|--------------------------------------|---------|
| OMNI 375 Features | 1 |
| Manifold-Air Pilot Operated | 2 & 3 |
| Air Pilot Operated | 4 & 5 |
| Manually Operated | 6 & 7 |
| Mechanically Operated | 8 |
| Ordering Information | 9 |
| Stacking and Common Wireway | 10 & 11 |
| Manifold Mounted | 12 & 13 |
| 3 Position Valves | 14 |
| Pneumatic Timer | 15 |
| Electronic Timer | 16 |
| Engineering and Technical Data | 17 |
| Replacement Parts | 18 |

The Unique "Thin Lip" Seal and Spool Features

- Teflon loaded viton seals provide millions of trouble free cycles
- Minimal breakout friction
- Unique wiping action eliminates contaminant build-up in bore
- Reduces spool hang-up due to compressor or oil varnishing (typical of lapped spool valves)
- Operates effectively in lubricated or non-lubricated systems

The Unique "Thin Lip" Seal

The Unique "Thin Lip" Seal:

- offers minimum breakout friction
- provides wiping action that keeps bore clean and evenly distributes lubrication

How It Works (Refer to Spool Illustration)

- a. "Relaxed" no pressure on either side of seal.
- b. Pressure from right moves seal to left, expanding it against the bore to sealed position.
- c. Force applied to left shifts spool ... nominal seating friction causes lip to flex like diaphragm. Flexing action reduces breakout friction. This spool can react quickly with very low force requirement.

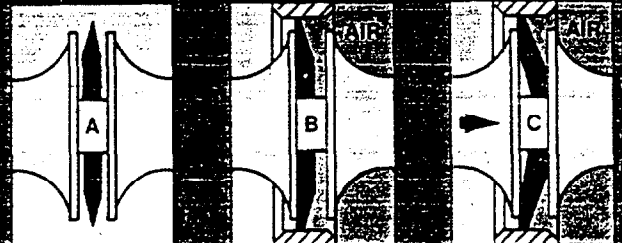

OMNI 375 has it all!

- DESIGN:**
- Patented Teflon Loaded Viton "Thin Lip Seal"
 - Minimum breakout friction.
 - Anodized extruded aluminum
 - Compact size.
 - 2 and 3 position.
 - Maximum service life.
- FLOW:**
- Highest in Industry 2.3 Cv.
 - Double the flow of most similar size valves.
- VERSATILITY:**
- Ten Standard Body Styles
 - 50 standard primary operators.
 - Proven performer in both lubricated and dry systems.
 - Adaptable for vacuum and low pressures.
 - Operates on standard filtration.

- MOUNTABILITY:**
- In Line
 - Base Mount
 - Stacking
 - Manifold
- SERVICE LIFE:**
- Designed and Built to Last
 - Minimum maintenance
 - 18 month warranty
- SIMPLICITY:**
- Minimum Parts
 - Easy to use
 - Easy to order
 - Simple to maintain

Simple Design and Super Performance from a 1/4" and 3/8" NPTF Power and Control Valve...
Engineering makes the ISI OMNI 375 beautifully simple.
Quality built to Out Perform the competition.
Price keeps it extremely Competitive.
Delivery on time through a Worldwide Distributor Network.

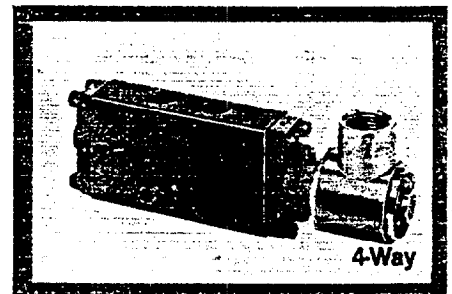
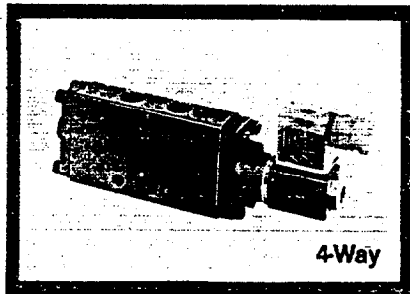
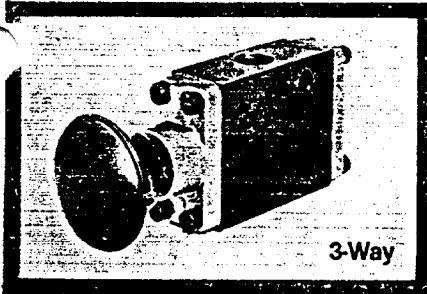

HOW THE SLEEVE AND PLUNGER SOLENOID AIR PILOT ASSEMBLY WORKS:

The diagram at right shows how this assembly works. Pilot air for the solenoid pilot is supplied from main line air through internal valve passage "A." With the solenoid in the de-energized position, the spring-loaded plunger seals against the air inlet "B." When the solenoid is energized, the plunger moves back and its top seat seals against the exhaust outlet "E." The top seat of the plunger is spring compensated against wear to assure complete, lifetime sealing. When the plunger moves off inlet port "B," the pilot air passes through outlet "C" to act on the end of the spool "D" causing the spool to shift. When the solenoid is de-energized, the plunger returns back to its starting position, the pilot air exhausts out of the spool chamber through inlet "C," past the plunger and out through outlet "E" to atmosphere.

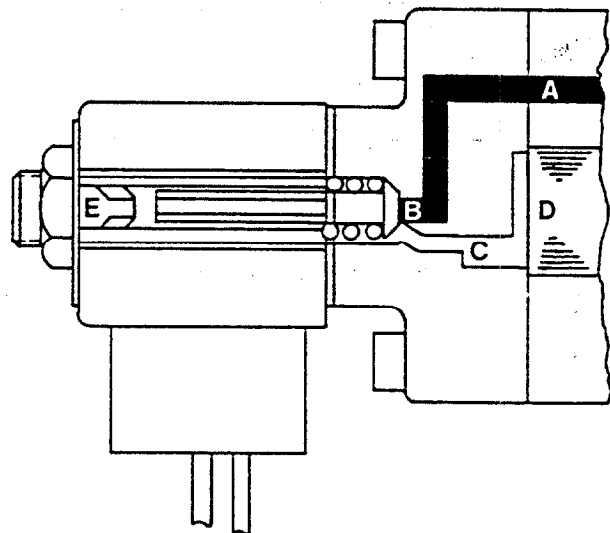

3-Way and 4-Way Air Pilot Operated

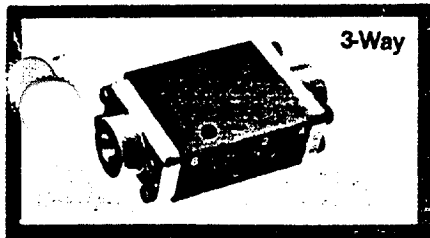

3-Way

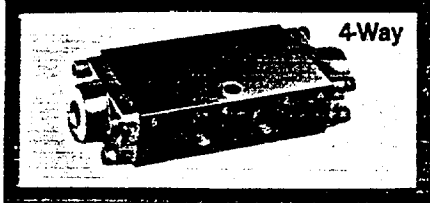

4-Way

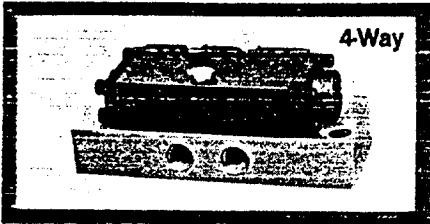

4-Way

THE OMNI 375 SERIES 3-WAY AND 4-WAY VALVES can be air pilot operated with three types of assembly.

1. DOUBLE AIR PILOT (NO VALVE SPOOL SPRING)

The valve spool is shifted by a momentary air pilot signal to either of the "A" or "B" Pilots.

2. SINGLE AIR PILOT, SPRING RETURN

The valve spool is maintained in the normal rest position by the spring in the "B" end. A maintained air pressure signal at the "A" end greater than the spring force will shift the valve spool.

3. DOUBLE AIR PILOT, SPRING OFFSET

The valve spool is maintained in the normal rest position by a spring in the "B" end. A maintained air pressure signal at the "A" end greater than the spring force will shift the valve spool, providing no air pressure signal is on the "B" end. By controlling the pressure differential between "A" and "B," a variety of applications are possible.

3-Way

Single Air Pilot

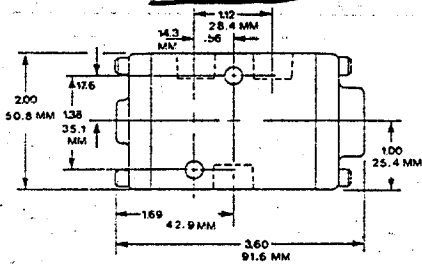

03 Air Pilot

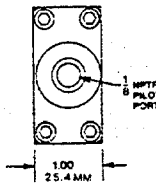

Double Air Pilot

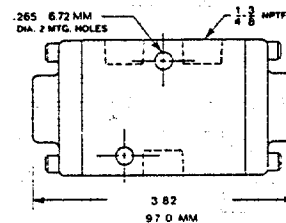

4-Way

Single Air Pilot

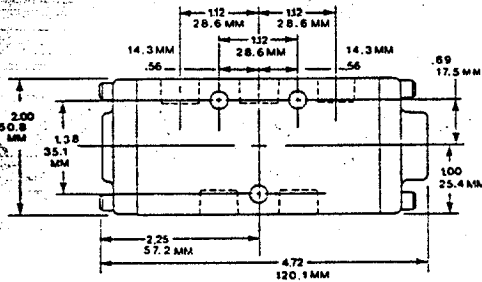

03 Air Pilot

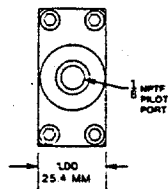

Double Air Pilot

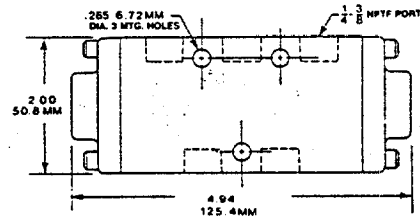

BASE MOUNT

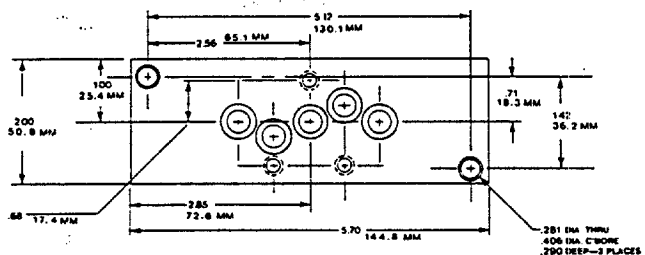
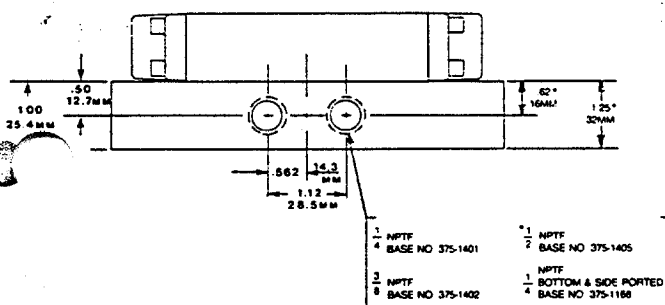

BASIC VALVE MODEL NUMBERS

| DESCRIPTION | 3-Way | | | 4-Way | | |
|---|-----------|---------------|------------|-----------|---------------|------------|
| | PIPE SIZE | NUMBER | SCHEMATICS | PIPE SIZE | NUMBER | SCHEMATICS |
| Single Air Pilot Spring Return 652479 | 1/4 NPTF | 375-02-007-03 | | 1/4 NPTF | 375-02-001-03 | |
| | 3/8 NPTF | 375-02-087-03 | | 3/8 NPTF | 375-02-081-03 | |
| Double Air Pilot | 1/4 NPTF | 375-03-007-03 | | 1/4 NPTF | 375-03-001-03 | |
| | 3/8 NPTF | 375-03-087-03 | | 3/8 NPTF | 375-03-081-03 | |
| Double Air Pilot Spring Biased | 1/4 NPTF | 375-04-007-03 | | 1/4 NPTF | 375-04-001-03 | |
| | 3/8 NPTF | 375-04-087-03 | | 3/8 NPTF | 375-04-081-03 | |

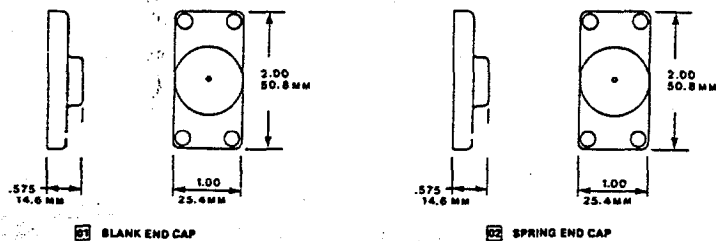

This Series of 4-way valves is available with base mounting which permits the removal or changing of a valve without disturbing the piping. The 375 Series base is machined from extruded aluminum and available with 5 threaded ports in 1/4", 3/8" or 1/2" NPTF. The valve body (004) has five unthreaded ports on the wide part of the valve which mate with the five ports on the top of the base. The body is supplied with five Viton o'rings and is assembled to the base.

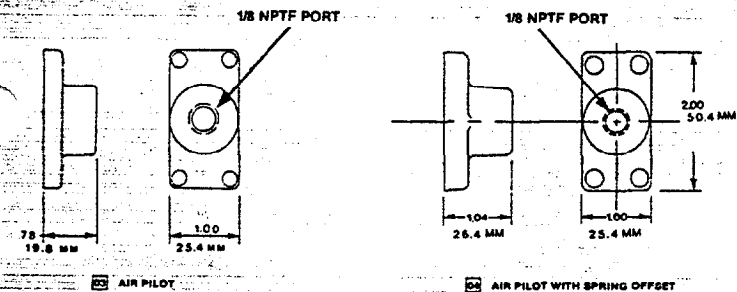

| DESCRIPTION | PIPE SIZE | NUMBER |
|--|-----------|---------------|
| Air pilot, spring return valve, base mounted, valve only | | 375-02-004-03 |
| Side Ported Base | 1/4 NPTF | 375-1401 |
| | 3/8 NPTF | 375-1402 |
| | 1/2 NPTF | 375-1405 |
| Side & Bottom Ported Base | 1/4 NPTF | 375-1168 |

Note: Valves and bases must be ordered separately.

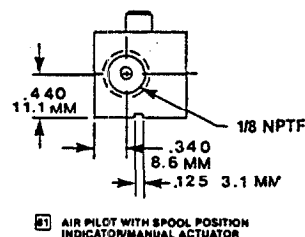
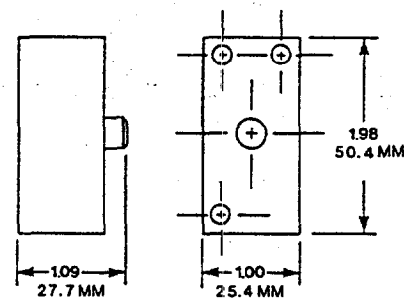
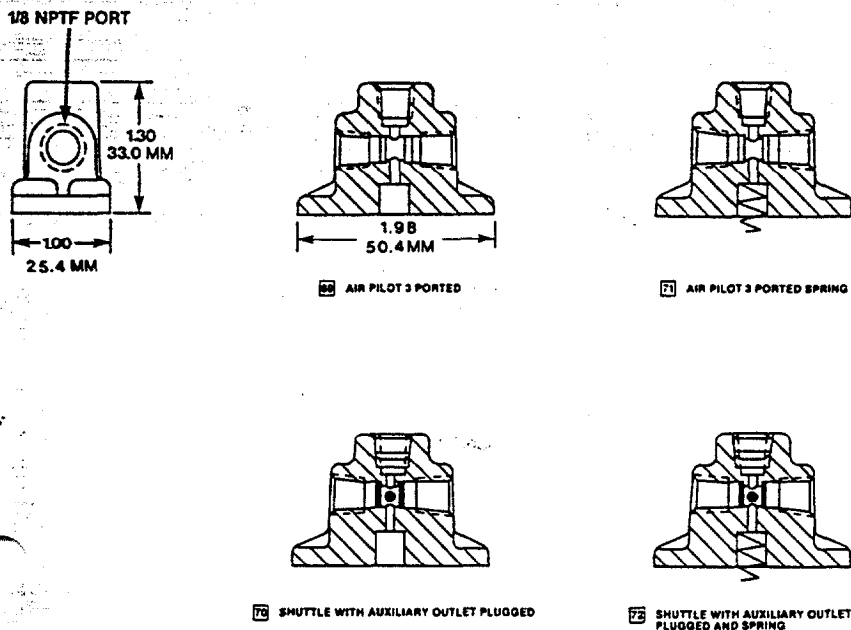

Ordering Information

SERIES DESIGNATION

| Series | "B" | Body/Base | "A" | Volts/Hertz |
|--------|-----|-----------|-----|-------------|
| 375 | 02 | 001 | 33 | 120/60 |

Ordering Procedure for An OMNI 375

1. Series Designation 375 identifies the valve series.
2. "B" Operator: This is the secondary operator. It returns the spool.
3. Body Style: The OMNI 375 is a 2 or 3 position valve. The body style selects type of mounting and port size. (see page 14 for 3 position valves.)
4. "A" Operator: This is the primary operator. The primary operator moves the spool away from the start position.
5. Specify voltages or any other special conditions.
6. For stacking valves refer to pages 10 & 11 for additional information.
7. For manifold valves, refer to pages 12 & 13.

NOTE

Air pilot or solenoid operators may be used with either 2 position or 3 position body styles. Din connector available with light, please specify.

Space limitations may require spacers when used for valve stacking; consult factory.

• Standard Voltages: 120/60, 240/60, 24/60, 12 VDC, 24 VDC, 120 VDC

• Specify Voltage and Hertz of Solenoids.

• High Temperature Solenoids Available — Consult Factory.

• Military Service and Brad Harrison Connectors Available.

| Operators | |
|---|-----|
| Blank end cap | 01 |
| Spring return cap | 02 |
| Air Pilot | 03 |
| Air Pilot w/spring offset | 04 |
| Knob push | 05 |
| Knob, detented, push-pull | 06 |
| Knob, panel mtd., push | 07 |
| Knob, panel mtd., detented, push-pull | 08 |
| Palm button, push only | 09 |
| Palm button, panel mtd. | 10 |
| Palm button, w/guard | 11 |
| Palm button, panel mount, with guard | 12 |
| Parallel side, or straight lever | 13 |
| Parallel side, or straight lever, detented, push-pull | 15 |
| Perpendicular side or straight lever | 17 |
| Perpendicular side or straight lever detented push-pull | 19 |
| Steel plunger | 27 |
| Parallel roller lever, actuate left | 30 |
| Parallel roller lever, actuate right | 31 |
| Parallel roller lever, two way | 32 |
| Solenoid air pilot with conduit connection | 33 |
| Foot operator | 34 |
| Foot operator—guarded | 34G |
| Solenoid air pilot w/manual o'ride and conduit conn. | 37 |
| Solenoid air pilot w/locking manual o'ride | 38 |
| Foot treadle oper., detented, push-pull | 39 |
| Foot treadle oper., detented, push-pull—guarded | 39G |
| Explosion-Proof solenoid air pilot, w/conduit conn. and man. o'ride | 42 |
| Panel mtd. palm button, detented, push-pull | 43 |
| Knob select panel mounted | 44 |
| Key select; panel mounted | 45 |
| Micro timer-on delay w/manual o'ride & light | 50 |
| Micro timer-off delay w/manual o'ride & light | 51 |
| Micro timer-Interval w/manual o'ride & light | 52 |
| Micro timer-cycle w/manual o'ride & light | 53 |
| Solenoid air pilot w/grommet conn. | 60 |
| Solenoid air pilot w/grommet conn. & man. o'ride | 61 |













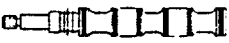



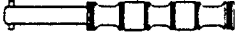





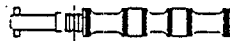



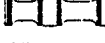

Bodies:

| | |
|--|-----|
| 1/4" NPTF Individual 4-way | 001 |
| 3/8" NPTF Individual 4-way | 081 |
| 1/4" NPTF Individual 3-way | 007 |
| 3/8" NPTF Individual 3-way | 087 |
| 1/4" NPTF stacking 4-way with individual exhaust | 002 |
| 3/8" NPTF stacking 4-way with individual exhaust | 082 |
| 1/4" NPTF stacking 4-way | 003 |
| 3/8" NPTF stacking 4-way | 083 |
| 1/4" NPTF common wireway 4-way | 009 |
| 3/8" NPTF common wireway 4-way | 089 |
| 1/4" NPTF integral flow control | 0F9 |
| 4-way base mount | 004 |

Operators:

| | |
|---|-----|
| Solenoid external air pilot w/grommet conn. | 62 |
| Solenoid external air pilot w/grommet conn. & man. o'ride | 63 |
| Solenoid external air pilot w/conduit connection | 64 |
| Solenoid external air pilot w/conduit conn. & man. o'ride | 65 |
| Explosion proof solenoid external air pilot w/conduit conn. & man. o'ride | 66 |
| Solenoid air pilot w/din connector | 67 |
| Solenoid air pilot, common wireway | 67C |
| Solenoid air pilot w/din connector & man. o'ride | 68 |
| Solenoid air pilot, manual o'ride, common wireway | 68C |
| Air pilot, three ported | 69 |
| Shuttle w/auxiliary outlet plugged | 70 |
| Air pilot three ported spring offset | 71 |
| Shuttle w/auxiliary outlet plugged, spring offset | 72 |
| Solenoid air pilot, J.I.C., | 74 |
| Air pilot w/spool position indicator, man. actuator | 81 |
| Solenoid air pilot, din, w/locking man. o'ride | 82 |
| Solenoid air pilot, locking manual o'ride | 82C |
| Air pilot, manual actuator | 83 |
| Solenoid air pilot, manual o'ride, external pilot supply | 86C |

Replacement Parts

| OPERATOR No. | SPOOL REPLACEMENT* | | | | | | |
|----------------------|---|---|--|---|---|--|---|
| 06, 08, 43 |  3-WAY 2 POSITION 90A20095 |  4-WAY 2 POSITION 90A20106 |  3 POSITION E 90A20180 |  3 POSITION B 90A20179 |  3 POSITION P 90A20181 | | |
| 13, 17 |  3-WAY 2 POSITION 90A20076 |  4-WAY 2 POSITION 90A20075 |  3 POSITION B 90A20182 |  3 POSITION E 90A20183 |  3 POSITION P 90A20184 | | |
| 15, 19 |  3-WAY 2 POSITION 90A20112 |  4-WAY 2 POSITION 90A20113 |  3 POSITION B 90A20185 |  3 POSITION E 90A20186 |  3 POSITION P 90A20187 | | |
| FOOT PEDAL 34, 39 |  3-WAY 2 POSITION 90A20116 |  4-WAY 2 POSITION 90A20117 | | | | | |
| 4, 74 |  SINGLE SOLENOID 90A20076 |  DOUBLE SOLENOID 90A20077 |  SINGLE SOLENOID 90A20075 |  DOUBLE SOLENOID 90A20074 |  3 POSITION B 90A20188 |  3 POSITION E 90A20189 |  3 POSITION P 90A20190 |
| 27, 30, 31, 32 |  3-WAY 2 POSITION 90A20076 |  4-WAY 2 POSITION 90A20127 | | | | | |
| ALL OTHERS |  3 POSITION B 90A20175 |  3 POSITION E 90A20176 |  3 POSITION P 90A20177 |  3-WAY 2 POSITION 90A20078 |  4-WAY 2 POSITION 90A20075 | | |

*Material: Aluminum is standard. Delrin available on some operators. Consult factory.

COIL REPLACEMENT

| DESCRIPTION | MOLDED |
|--|----------|
| Coil with conduit housing 33, 37, 38, 64, 65, 78, operators | 26E01017 |
| Coil with grommet housing 60, 61, 62, 63 operators | 26E01033 |
| Coil only for J.I.C. housing 74 operator | 26E01000 |
| Coil for explosion proof housing operators | 26E01043 |
| Coil for din. connector | 26E01039 |

• When ordering coil, give part no. and voltage. Standard voltages are: 120/60, 240/60, 24/60, 12VDC, 24VDC, 120VDC. For other voltages, consult factory.

OPERATOR REPLACEMENT

- For solenoid operators, specify if operator is for "A" end or "B" end of valve.
 - For air piloted valves, manual valves, and mechanically operated valves, furnish operator number only.
- EXAMPLE: "A" end 37 operator 120/60



ISI Fluid Power











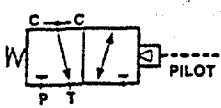
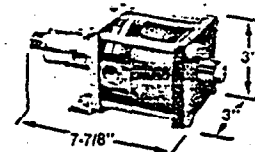
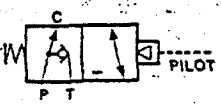
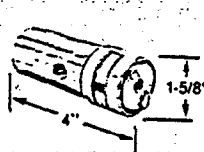
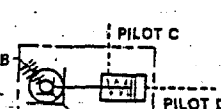
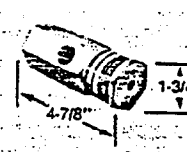
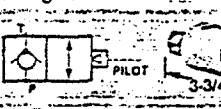

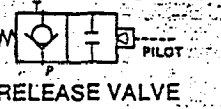

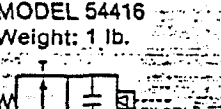
P.O. Box 400

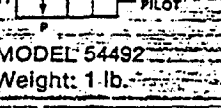
34575 Commerce Road

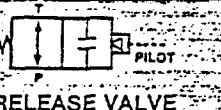
Fraser, Michigan 48026 U.S.A.

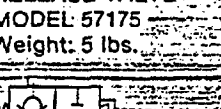
(313) 294-9300 • FAX (313) 294-5454

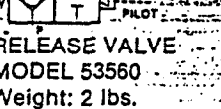
Air Piloted Valves

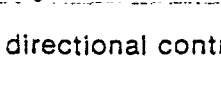
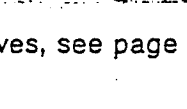
| TYPE | NORMAL POSITION | SCHEMATIC WITH APPROX. WEIGHT AND SIZE | MODEL NUMBER | REMARKS |
|-------|-----------------|---|---|---|
| 3 Way | Closed |  Weight: 5 3/4 lbs. |  50135 | <ul style="list-style-type: none"> • Closed crossover • Dual C porting |
| | |  Weight: 1 lb. |  53430-4 53430-5 53430-6 53430-7 | <ul style="list-style-type: none"> • Same as above and includes manual override • Open crossover • Rated for plain water |
| | |  Weight: 5 lbs. |  28940 28940-1 | <ul style="list-style-type: none"> • 2 stage decompression and release • Rated for plain water |
| 2 Way | Closed |  Weight: 5 lbs. |  RELEASE VALVE MODELS 28940, 53581 | <ul style="list-style-type: none"> • 2 stage decompression and release • Single stage release • Rated for plain water |
| | |  Weight: 1 lb. |  RELEASE VALVE MODEL 53585 | |
| | |  Weight: 1 lb. |  MODEL 54416 MODEL 54492-1 MODEL 54416-1 MODEL 54492 | |
| | |  Weight: 1 lb. |  MODEL 54416-2 MODEL 54492-2 MODEL 54416-3 MODEL 54492-3 | |
| 2 Way | Open |  Weight: 1 lb. |  MODEL 54416-4 MODEL 54492-4 | <ul style="list-style-type: none"> • Rated for plain water • 54492 is needle type allowing flow in either direction |
| | |  Weight: 5 lbs. |  RELEASE VALVE MODEL 57175 | |
| | |  Weight: 2 lbs. |  RELEASE VALVE MODEL 53560 | |
| | |  Weight: 2 lbs. |  RELEASE VALVE MODEL 53580-150 | <ul style="list-style-type: none"> • Designed for mounting inside tank |

NOTE: For oil piloted directional control valves, see page 8.



1/3 HP PUMPS - M SERIES, M, MS, MCP, MDTV, MDSTV, AND 29723 MODELS

Technical Specifications and Performance Data

This brochure contains technical information on the M-series 1/3 HP Liquid Pumps which includes model selection, installation, operation, maintenance, performance characteristics and weights and dimensions. It should be read in conjunction with the Haskel MLP-46 Catalog — An Introduction to Air Driven Liquid Pumps, and with the assembly drawings when supplied as part of the O/M manual with a pump.

INTRODUCTION

Study the Haskel Introduction to Air Driven Liquid Pumps MLP-46 Catalog. See pages 2 and 3 for basic details and principles of operation and pages 4 and 5 for specific information on the 1/3 hp M-series. See page 9 for wetted materials of construction. See pages 10 through 15 for options, modifications and power units.

INSTALLATION

The Haskel Pump can be mounted in any position and should be secured by the two mounting brackets. Alternatively, the hydraulic inlet can be directly mounted to a tank top. However, models with separation chamber construction (all MD, MCP and 29723 models) should be mounted vertically so that any fluid leakage from the chamber vent port will not migrate into the air drive section. Pump can be mounted in a horizontal position providing the vent port is facing down. Do not pipe vent port back to fluid source.

AIR DRIVE SYSTEM

Other gases such as nitrogen, CO₂, natural gas — even sour gas can be used as alternatives to compressed air when properly modified.

The air drive requires a minimum pressure of 25 psi (1.72 bar) to actuate the air cycling valve spoon. However, 40 psi is the recommended minimum for long term reliable operation. The maximum air drive pressure is 125 psi (8.6 bar). It is not necessary or desirable to use an air lubricator. The air drive section of all Haskel liquid pumps are lubricated at the time of assembly with Haskel Lubricant 28442.

The air drive requires no other means of lubrication. Install an airline filter and pressure regulator with a minimum of 1/4" npt port size. Also review air system upstream and eliminate any restrictions to provide 1/4" minimum inside diameter. Install a shut-off/speed control valve, 1/4" npt, at pump inlet port. See top left of page 10 'Air Controls' in MLP-46 Catalog for typical layout.

HYDRAULIC SYSTEM

See page 3 of the data catalog for fluid inlet/outlet port sizes.

Note: Inlet fluid supply piping should not be less than 1/4" I.D. Restricting the fluid supply will result in lower outlet flow rates and cause pump to cavitate.

Larger piping should be used with heavy fluids or if suction lift is over 3 feet.

Caution: Do not loosen liquid inlet or liquid outlet fittings of pump to facilitate make up of piping connections. These fittings must be tight to avoid leakage or damage. A suction filter must be installed in liquid inlet line. 100 x 100 mesh is normally ample to protect the pump seals and check valves.

Note: See curves on page 2 and/or label on pump for safe maximum pressure ratings.

Priming

Install a valve of suitable working pressure to the pump outlet that is capable of being used as an air bleed to start up. Open air control valve slowly. Allow pump to cycle for approximately fifteen seconds pumping fluid through the valve. If adequately primed, close the valve. The pump will cycle slower and then stall due to increase in output resistance. If the pump does not stall, open the valve and repeat the procedure.

OPERATION

The pump model number indicates the ratio between the area of the air piston and the liquid piston. See page 3 'Principle of Operation' in the MLP-46 Catalog.

The liquid outlet pressure can be controlled quite accurately by regulating the air drive pressure. The pump will cycle rapidly initially

and as it approaches an output pressure equal to the ratio times the air drive pressure, it will gradually slow down and finally 'stall'. (Also note remarks on page 2.)

Where it is necessary to obtain maximum outlet flow rates up to a predetermined pressure, a Haskel Air Pilot Switch should be installed at the pump outlet to automatically stop the pump at the final pressure. The airline regulator should be set at 125 psi (8.6 bar). A Haskel Relief Valve to prevent over pressurization should also be fitted as a safety precaution. See top of page 17 'Air Pilot Switch' and 'Regulating Relief Valves', and page 18 of MLP-46 Catalog.

Note: A hand pump attachment can be fitted (for precision control or use without compressed air power) on all models. (Ref. page 10, MLP-46.)

(Continued on page 4)

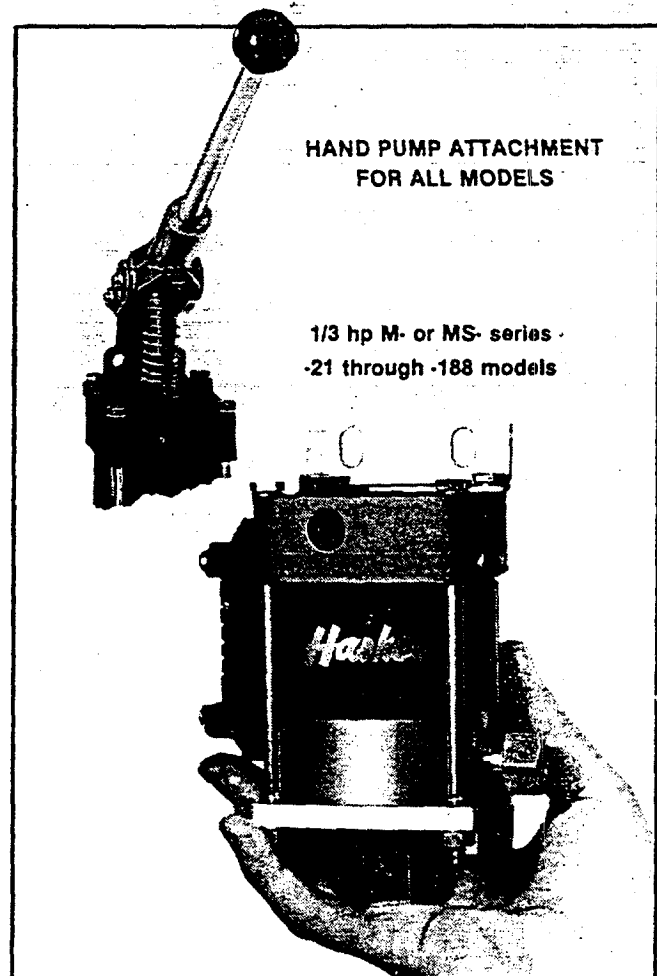

PUMP PERFORMANCE ALL MODELS

These curves show the capability of each model using 75, 100, and 125, psig drive pressures (intermediate pressures can be easily interpolated). Tests were run with the air pressure initially set at a static condition with a supply line equivalent to 1/4" schedule 40 pipe. A standard 1/4" NPT filter-regulator was installed on the pump drive.

Note: "Mini" type air regulators (as supplied with -c air

controls) will reduce output flow by about 25%.

Stall Pressure: As can be seen from the cutaway view on page 4, the drive is returned with a large coil spring. Drive force can vary up to 2 psi (equivalent) between the top and bottom of the stroke. This variance is multiplied by the area ratio at stall. Therefore, for precise test work the HP (Hand Pump modification) is recommended.

PERFORMANCE CURVES

AIR DRIVE PRESSURE (Solid curve lines) / AIR DRIVE FLOW (Dotted curve lines)

Shaded areas indicate excessive cycle rates and should be avoided except for intermittent duty.

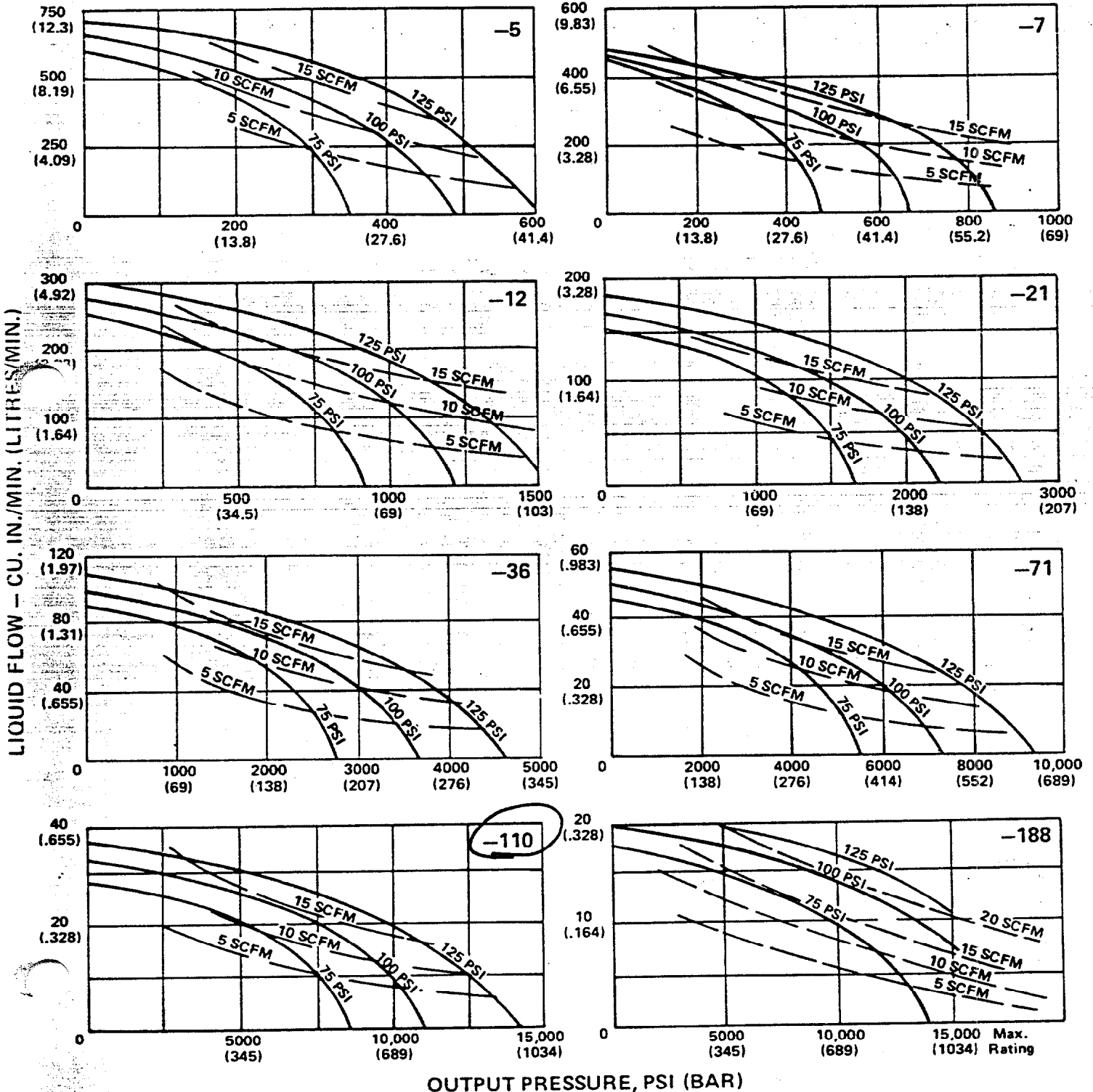

OUTPUT PRESSURE, PSI (BAR)

INSTALLATION INFORMATION

PRESSUREPAC POWER UNITS

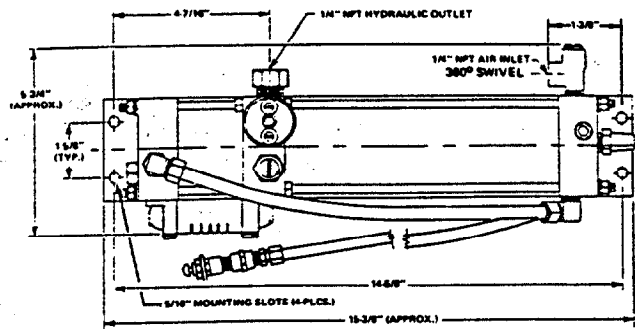

OVERALL APPROXIMATE HEIGHT: 6-5/8"

28910 SERIES (TOP VIEW) Approx. Wt. 8 lbs. [without oil]

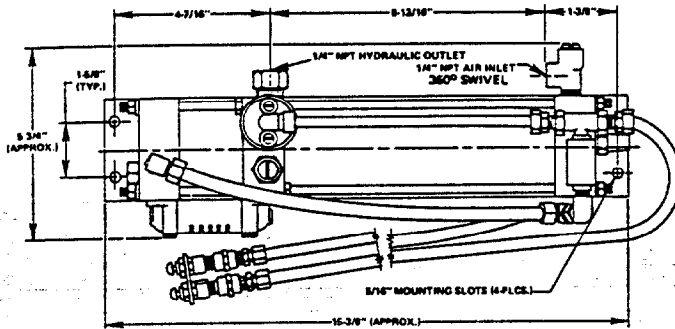

OVERALL APPROXIMATE HEIGHT: 6-5/8"

29880 SERIES (TOP VIEW) Approx. Wt. 8 lbs. [without oil]

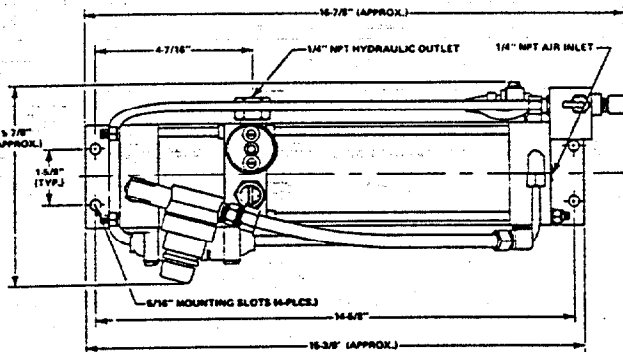

OVERALL APPROXIMATE HEIGHT: 8-1/4"

29230 SERIES (TOP VIEW) Approx. Wt. 9 1/2 lbs. [without oil]

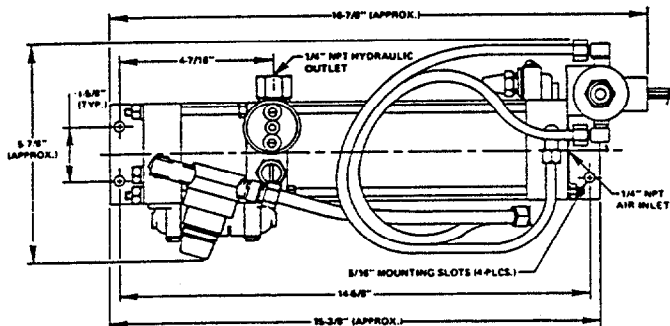

OVERALL APPROXIMATE HEIGHT: 8-1/4"

29883 SERIES (TOP VIEW) Approx. Wt. 9 1/2 lbs. [without oil]

PUMPS

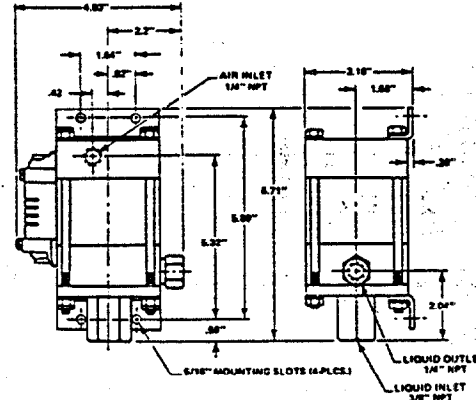

M-21, M-36, M-71,
M-110, M-188
Approx. Wt. 6 lbs.

MS-21, MS-36, MS-71,
MS-110, MS-188
Approx. Wt. 6 lbs.

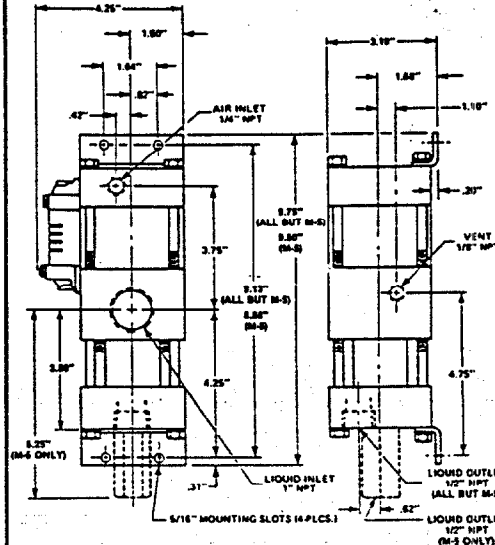

MDTV-5, MDTE-5
Approx. Wt. 11 lbs.

MDSTV-5, MDSTE-5
Approx. Wt. 15 1/2 lbs.

M-5
Approx. Wt. 6 lbs.
(M-5 dimensions shown in phantom)

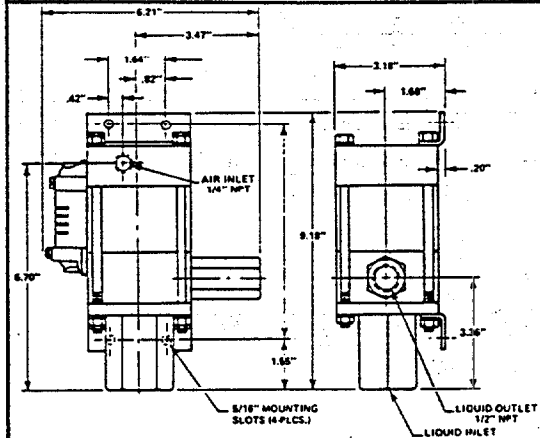

M-7, M-12
Approx. Wt. 9 lbs.

MS-7, MS-12
Approx. Wt. 9 lbs.

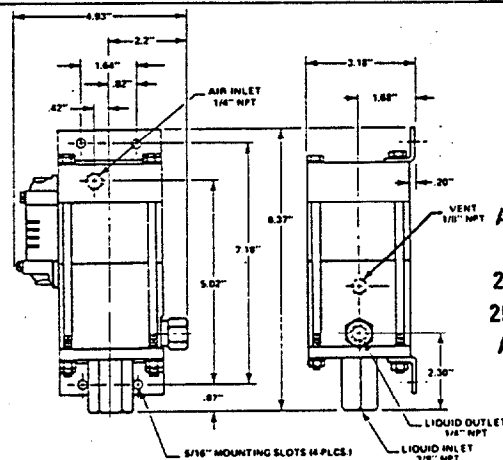

MCP-21, MCP-36,
MCP-71, MCP-110
Approx. Wt. 6 1/2 lbs.

29723-21, 29723-36,
29723-71, 29723-110
Approx. Wt. 6 1/2 lbs.

MAINTENANCE (Continued from page 1)

Disconnect pump from system and remove to a clean, well lit work bench with access to vice, tools, seal kits and spares. All parts removed for inspection should be washed in a suitable de-greasing agent such as Stoddard solvent or equivalent. Inspect all moving parts for wear or scratches. Damaged parts should be replaced. It is recommended that all seals and O-rings are replaced. Specially packaged seal kits are available for:

Air Drive P/N 17178 (common to all standard models)

HYDRAULIC SECTION

P/N 17179 (plus ratio no.)
 P/N 26410 (plus ratio no.)
 P/N 28247 (plus ratio no.)
 P/N 51104 (plus ratio no.)
 P/N 27901
 P/N 53694
 P/N 28696
 P/N 28695
 P/N 51239
 P/N 51240

Model No.

M-21 thru -188
 MS-21 thru -188
 MCP-21 thru -110
 29723-21 thru -110
 MDTV-5, MDSTV-5
 M-5
 M-7
 M-12
 MS-7
 MS-12

Air Drive Section

The air piston has a spring return. Care should be taken when dismantling to prevent the spring from causing the top cap to fly off. The most common cause of air drive malfunction is O-ring 568011-21 on the end of spool 17157. Inspect this first and replace if necessary prior to retesting before further disassembly of air drive. Spool 17157 is most easily removed by removing the muffler upper cap and carefully opening the air drive valve to push the spool and sleeve assembly out with compressed air. The spool and sleeve can be contained by holding a cloth over the exhaust port. The air piston, air barrel, cycling valve and sleeve should be relubricated on assembly with Haskel Silicone Grease P/N 28442. Torque the tie rod nuts evenly to 50 in. lbs.

Hydraulic Section

If dismantled for inspection and parts replacement use following torque values on re-assembly.

- Inlet check valve — ratios -7, -12 to 95 ft. lbs.
- Outlet check valve — ratios -21, -36 to 50 ft. lbs.
- Inlet check valve — ratios -71, -110, -188 to 125 ft. lbs.
- Outlet check valves — all ratios to 50 ft. lbs.

When ordering spare parts advise pump serial no., model no., spare part no., and description.

TROUBLE SHOOTING GUIDE

Pump will not cycle, pump bypasses air.

- Inadequate air
 - a. See comments on: Air drive systems, page 1 and air drive section, on this page.
 - b. Contaminated air system
- Remove sleeve and cycling spool (under upper cap of

muffler). Clean, inspect and lubricate with Haskel Lubricant 28442.

False cycle, leak from pilot exhaust (top center of cap).

- Leakage of pilot system.
- Install new air section seal kit.

Pump cycles without pumping or does not stall.

- Check valve(s) not seating or leak in system.
- Inspect check valve(s). First inlet check and then outlet check.

Pump fluid appears at muffler (or vent port on separation models).

- High pressure seal leakage.
- Install new liquid section seal kit.

Cross section of Haskel M- and MS- Series Pump

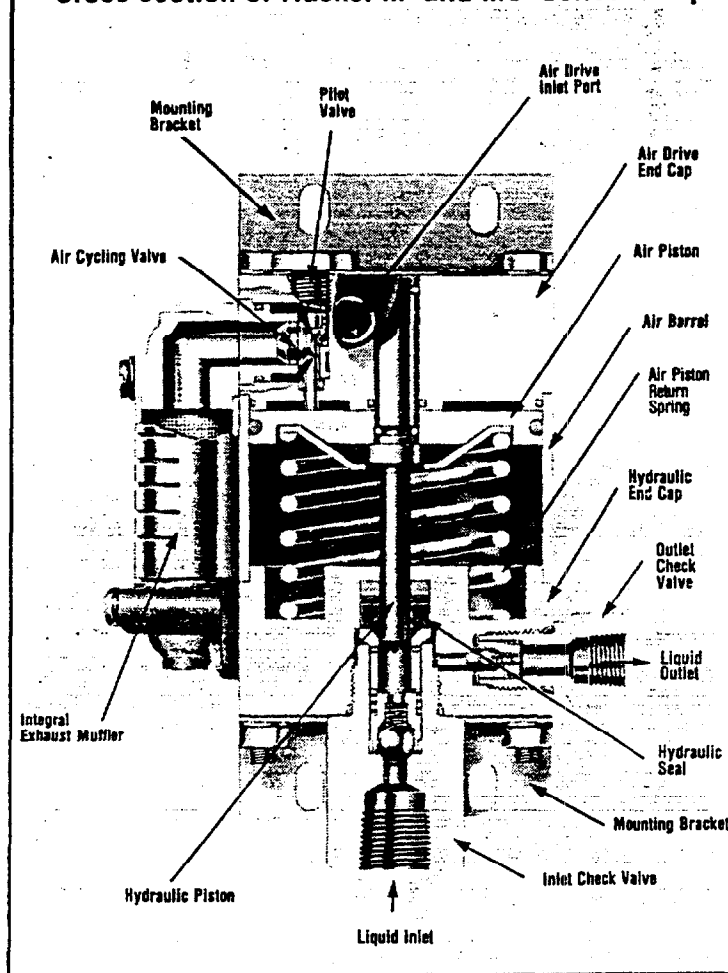

LIMITED WARRANTY

Haskel manufactured products are warranted free of original defects in material and workmanship for a period of one year from date of shipment to first user. This warranty does not include packings, seals, nor failures caused by lack of proper maintenance; incompatible fluids; foreign materials in the driving media; in the pumped media; or application of pressures beyond catalog ratings. Products believed to be originally defective may be returned, freight prepaid, for repair and/or replacement to the distributor, authorized service representative, or to the factory. If upon inspection by the factory or authorized service representative, the problem is found to be originally defective material or workmanship, repair or replacement will be made at no charge for labor or materials, F.O.B. the point of repair or replacement. Permission to return under warranty should be requested before shipment and include the following: the original purchase date, purchase order number, serial number, model number, or other pertinent data to establish warranty claim, and to expedite the return or replacement to the owner.

If pump has been disassembled and reassembled in a facility other than Haskel, warranty is void if it has been improperly reassembled or substitute parts have been used in place of factory manufactured parts.

Any modification to any Haskel product which you have made or may make in the future has been and will be at your sole risk and responsibility, and without Haskel's approval or consent. Haskel disclaims any and all liability, obligation, or responsibility for the modified product; and for any claims, demands, or causes of action for damage or for personal injuries resulting from the modification and/or use of such a modified Haskel product.

HASKEL'S OBLIGATION WITH RESPECT TO ITS PRODUCTS SHALL BE LIMITED TO REPLACEMENT, AND IN NO EVENT SHALL HASKEL BE LIABLE FOR ANY LOSS OR DAMAGE, CONSEQUENTIAL OR SPECIAL, OF WHATEVER KIND OR NATURE, OR ANY OTHER EXPENSE WHICH MAY ARISE IN CONNECTION WITH OR AS A RESULT OF SUCH PRODUCTS OR THE USE OR INCORPORATION THEREOF IN A JOB. THIS WARRANTY IS EXPRESSLY MADE IN LIEU OF ALL OTHER WARRANTIES OF MERCHANTABILITY AND FITNESS FOR A PARTICULAR PURPOSE. NO EXPRESS WARRANTIES AND NO IMPLIED WARRANTIES WHETHER OF MERCHANTABILITY OR FITNESS FOR A PARTICULAR PURPOSE OR OTHERWISE, OTHER THAN THOSE EXPRESSLY SET FORTH ABOVE, SHALL APPLY TO HASKEL PRODUCTS.

5.88 3000 Printed in U.S.A.

Haskel
 INC.

Burbank, CA 91502 • U.S.A. (818) 843-4000
 TLX: 18-1372 HASKEL BUBK FAX: (818) 841-4291

Haskel Energy Systems, Ltd. • Sunderland SR5 3JD • England
 91-549-1212 TLX: 53624 HIENGY G FAX: 91-549-0911

THE GENERAL PURPOSE & OPERATIVE PROPERTIES SHALL BE SHOWN BY THE MANUFACTURING MANUFACTURING AIR DRIVE AIR EQUIPMENT BY THE MANUFACTURER & SUPPLY OR

| REV. | DESCRIPTION | BY | DATE |
|------|---|----|------|
| 1 | 17193 CAP REMOVED (PART REVISED) | | |
| A | REMOVED: 26378 SCREW WITH LOCK WASHER (4 REQ) WASHER / 17183-3 (4 REQ) 26750 ADDED: 17201 LOCK W/ 17201-8 SHANK | | |
| B | 17193 AIR CAP REMOVED (PART REVISED) | | |
| C | 26750 WAS WITH BRACKET | | |
| D | SECURITY O-RING WAS 568013-3 O-RING | | |
| E | 50111 WAS AN 814-3 | | |
| F | 17193 WAS WITH BRACKET | | |
| G | 17193 WAS WITH BRACKET | | |
| H | 17193 WAS WITH BRACKET | | |
| I | 17193 WAS WITH BRACKET | | |
| J | 17193 WAS WITH BRACKET | | |
| K | 17193 WAS WITH BRACKET | | |
| L | 17193 WAS WITH BRACKET | | |
| M | 17193 WAS WITH BRACKET | | |
| N | 17193 WAS WITH BRACKET | | |
| O | 17193 WAS WITH BRACKET | | |
| P | 17193 WAS WITH BRACKET | | |
| Q | 17193 WAS WITH BRACKET | | |
| R | 17193 WAS WITH BRACKET | | |
| S | 17193 WAS WITH BRACKET | | |
| T | 17193 WAS WITH BRACKET | | |
| U | 17193 WAS WITH BRACKET | | |
| V | 17193 WAS WITH BRACKET | | |
| W | 17193 WAS WITH BRACKET | | |
| X | 17193 WAS WITH BRACKET | | |
| Y | 17193 WAS WITH BRACKET | | |
| Z | 17193 WAS WITH BRACKET | | |

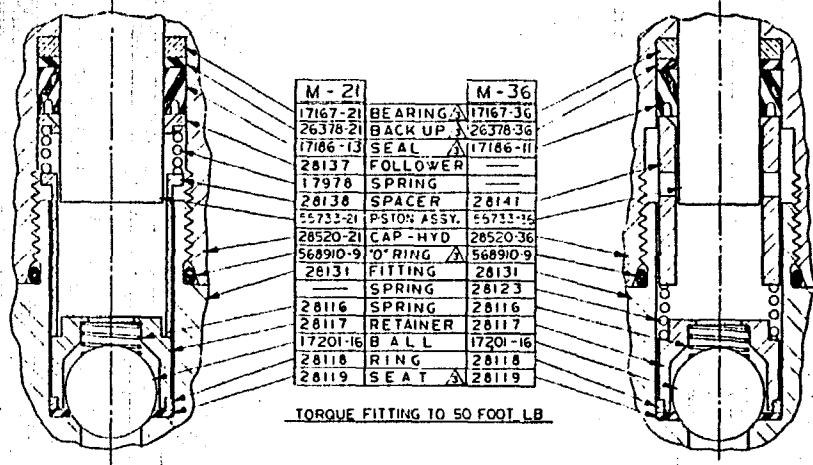
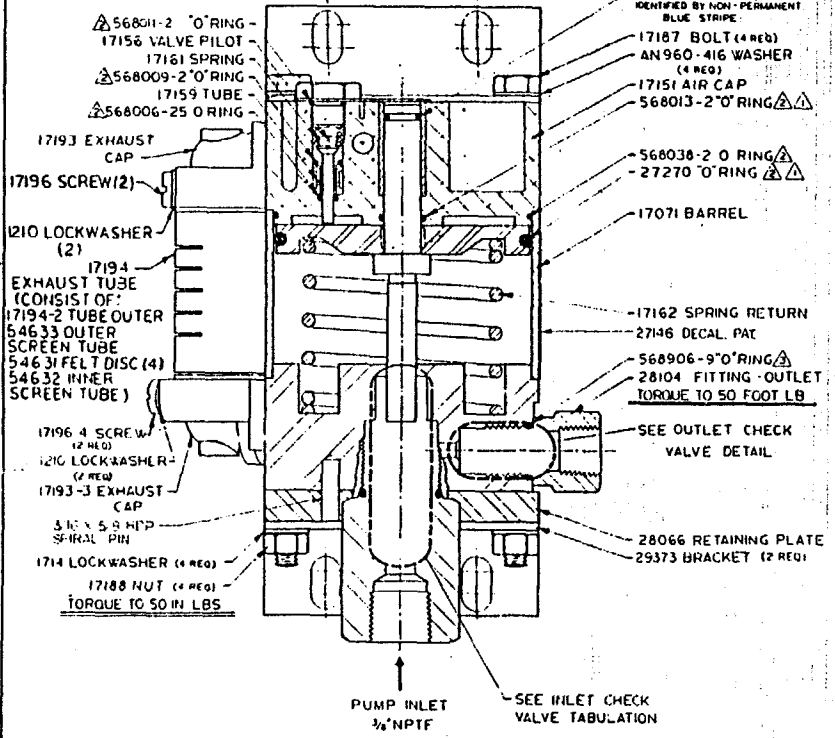
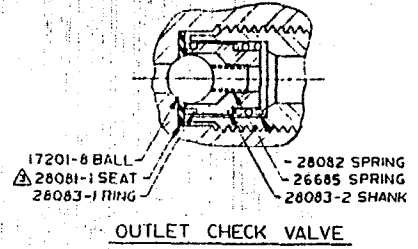
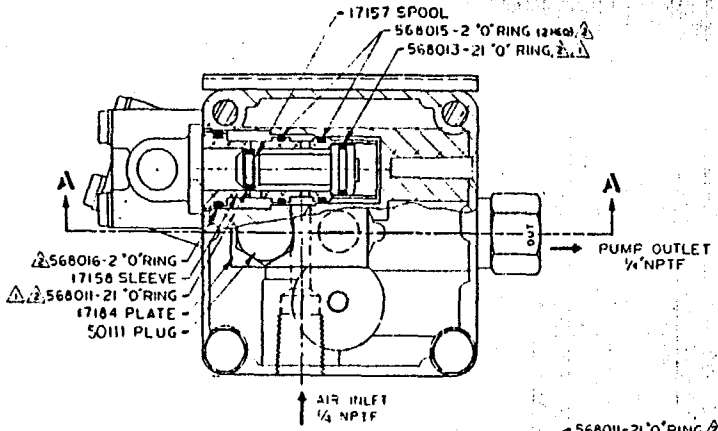

INLET CHECK VALVE M-21 AND M-36

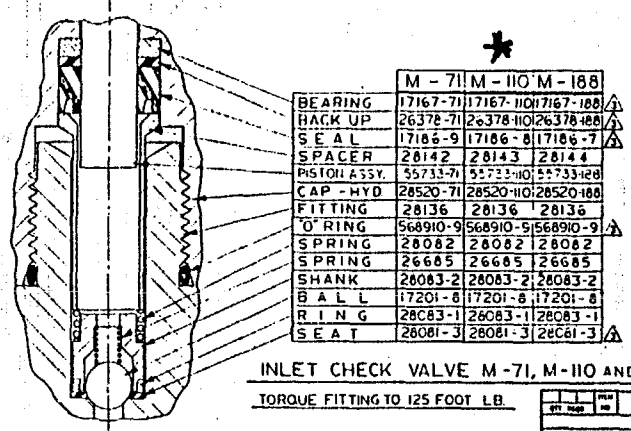

INLET CHECK VALVE M-71, M-110 AND M-188

- ⚠ THESE PARTS ARE INCLUDED IN 17179-XX HYDRAULIC SECTION SEALS KIT.
- ⚠ THESE PARTS ARE INCLUDED IN 17178 AIR DRIVE SEALS KIT.
- ⚠ APPLY VERY LIGHT COATING OF HASKEL LUBRICANT PN 28442 TO DYNAMIC SEALS IN AIR DRIVE SECTION.

NOIL

| REV. | DESCRIPTION | DATE |
|------|-------------------------------|------|
| 1 | ASSEMBLY DRAWING MODEL M PUMP | |

ASSEMBLY DRAWING
 MODEL M PUMP

814001 28550

28550F

Haskel

High Pressure Valves and System Components



Haskel AIR PILOT SWITCH
 PART NO: _____
 SERIAL NO: _____
 MAX OPER: 10000 PSIG
 ADJUSTABLE RANGE
 MIN. _____ PSIG
 MAX. _____ PSIG
 MADE IN U.S.A.

AIR PILOT SWITCH



15,000 PSI
2 STAGE
RELEASE VALVE



12,000 PSI
3 WAY VALVE

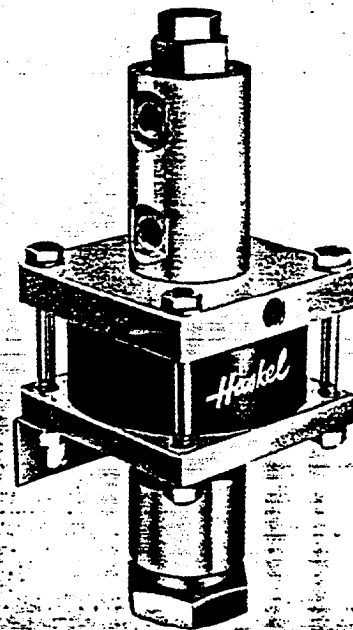

REMOTESET™
AIR PILOT SWITCH

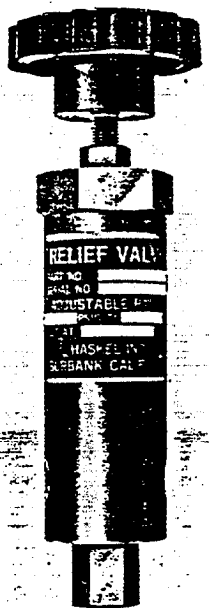

10,000 PSI
RELIEF VALVE

CONVENIENT CONVERSIONS:

- PRESSURE:
 - 1 BAR = 14.5 PSI
 - = 100 KPa
 - = 1.02 KG/CM²
 - 1 MPa = 10 BAR
- VOLUME:
 - 1 LITRE = 61 CU. IN.
 - 1 NM³ = 35.3 SCF
 - 1 SCF = 28.32NL
- LENGTH:
 - 1 INCH = 25.4 MM
- WEIGHT:
 - 1 KG = 2.2 LBS.
- POWER:
 - 1 HP = .746 KW.

**PNEUMOPULSE™
REPEAT CYCLE
CONTROLLER**

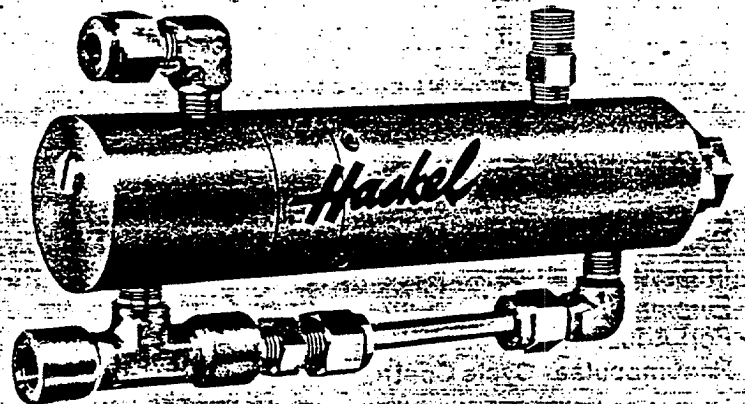

Air Pilot Switches

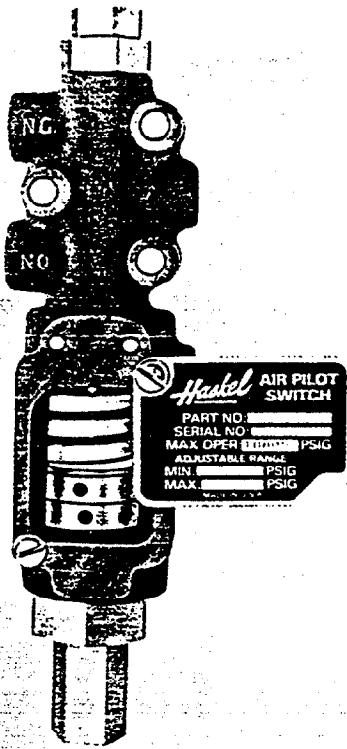

STYLE A

EXTERNALLY ADJUSTED

- 19 models.
- Sensing pressures to 25,000 psi.
- Air valve* 3 way, 2 way normally open or closed.

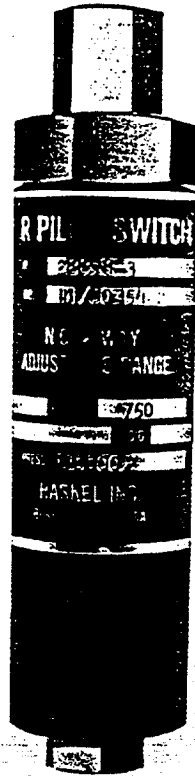

STYLE B

INTERNALLY ADJUSTED

- 40 models.
- Sensing pressures to 60,000 psi.
- Air valves* 3 way normally closed, 2 way normally closed, normally open.

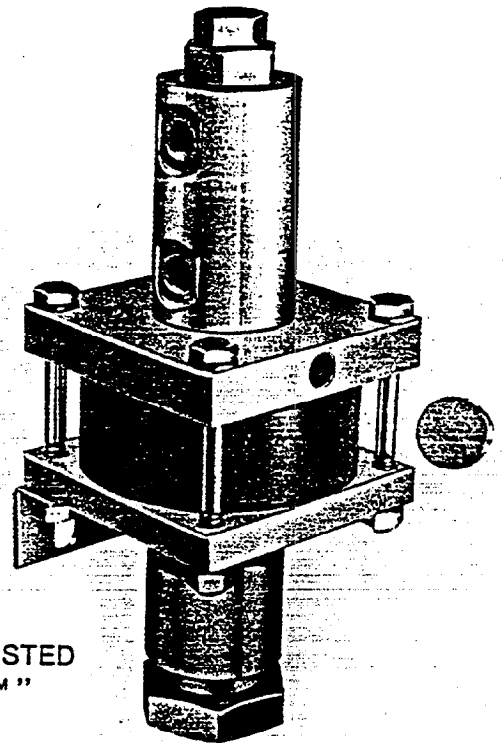

STYLE C

REMOTE AIR ADJUSTED " REMOTESET™ "

- 4 models.
- Sensing pressures to 25,000 psi.
- Air valve* 3 way, 2 way normally open or closed.

APPLICATION SCHEMATICS:

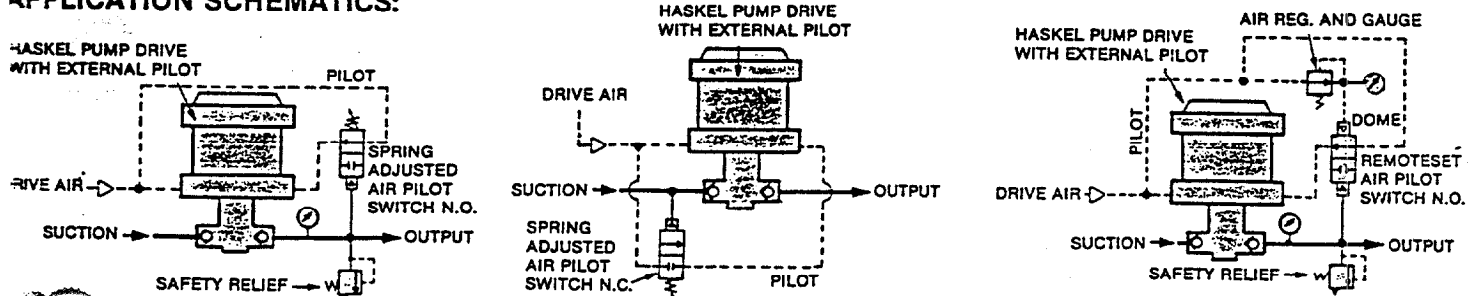

1. Maximum output pressure control, spring adjusted.

2. Minimum suction pressure control, spring adjusted.

3. Maximum output pressure control remote, air adjusted.

*Air valve terminology is the reverse of an electrical switch. Closed means no flow; open means flow.

Air Pilot Switches (Continued)

DESCRIPTION:

AN AIR PILOT SWITCH IS A PRESSURE SWITCH. These units produce a pneumatic signal up to 150 psi at any sensing pressure within their adjustment range. The signal valve may be piped normally open, normally closed*, 3 way or 2 way depending on model.

All models use a 2 position poppet type air signal valve which is shifted from its normal position by a rod from the sensing end which first must overcome an adjustable force spring (styles A and B) or air regulated dome loader (style C).

APPLICATIONS:

- Direct automatic start/stop control of any Haskel pump, gas booster, air amplifier or indirectly to the drive of any other pump or compressor sensing either output or suction (schematic 4).
- Valve actuators (schematic 5).
- Pneumatic alarm signals.
- Replace an explosion proof pressure switch in hazardous applications.

A word about "deadband":

Users often try to compare the on-off action of the air signal with the action of an electrical switch. They are not really comparable. The air switch has no "snap-over" mechanism required with an electric switch to prevent arcing. Therefore, "on" or "off" before or after a dead tight seal condition can be quite subjective. In other words, if the air pilot switch is turning on a device that only requires a miniscule leak to start, it will start much sooner than some other larger device that may need a flow of air to start. Therefore, it is not possible to publish precise deadband data such as that available for most electric pressure switches.

Style C Remoteset units have the lowest and most consistent deadband (5%—10% of set pressure) because there is no heavy coil spring to compress.

Styles A and B may vary from 5% to as high as 40% depending on model and the application details.

In some applications, a wider than normal deadband is needed. Schematic 5 illustrates how to provide this with two air pilot switches and a simple 2 position air valve.

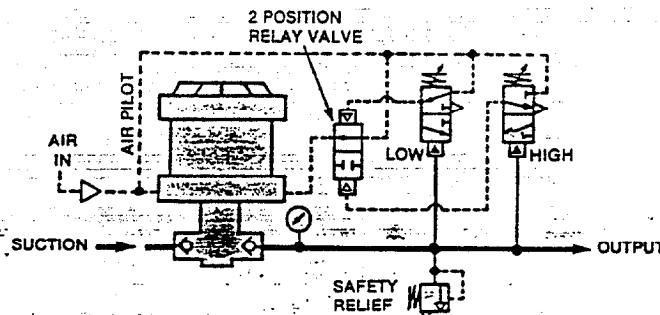

4. Wide deadband control with two adjustable air pilot switches plus a two position valve.

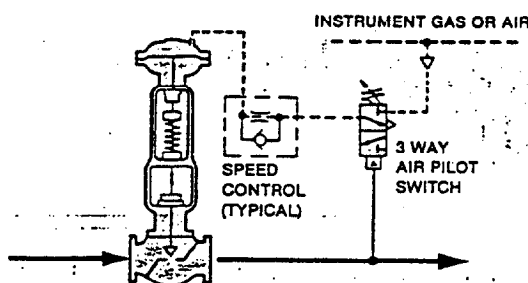

5. Process valve control.

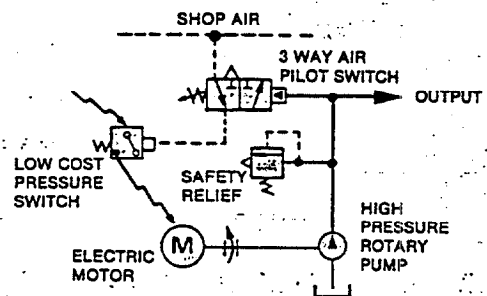

6. Electric pump/motor control where standard pressure switches are unsuitable at pump output.

CONVENIENT CONVERSIONS: PRESSURE: 1 BAR = 14.5 PSI = 100 KPa = 1.02 KG/CM², 1 MPa = 10 BAR • VOLUME: 1 LITRE = 61 CU. IN., 1 NM³ = 35.3 SCF, 1 SCF = 28.32NL
LENGTH: 1 INCH = 25.4 MM • WEIGHT: 1 KG = 2.2 LBS. • POWER: 1 HP = .746 KW.

Air Pilot Switches

| MODEL NO. | SERVICE SENSING PORT | LIQUID OR GAS | OXYGEN GAS |
|-----------|----------------------|----------------------|------------|
| 51940-1 | -11 | | |
| 51940-2 | -12 | | |
| 51940-3 | -13 | | |
| 52160-1 | -11 | | |
| 52160-2 | N/A | | |
| 52160-3 | -13 | | |
| 52180-1 | -11 | | |
| 52180-2 | -12 | | |
| 52180-3 | -13 | | |
| 55417-1 | -11 | | |
| 55417-2 | -12 | | |
| 28755-1 | -11 | | |
| 28755-2 | -12 | | |
| 28755-3 | -13 | | |
| 28791-1 | -11 | | |
| 28791-2 | -12 | | |
| 28791-3 | -13 | | |
| 28791-4 | -14 | | |
| 28898-1 | -11 | | |
| 28898-2 | -12 | | |
| 28898-3 | -13 | | |
| 28898-4 | -14 | | |
| 4-24 | N/A | | |
| 28974-25 | | | |
| 28974-59 | N/A | | |
| 28974-60 | | | |
| 29074-25 | N/A | | |
| 29074-60 | | | |
| 55750 | -11 | | |
| 55750-2 | -12 | | |
| 55416-1 | -11 | | |
| 55416-2 | -12 | | |
| 56650-1 | -11 | (REPLACES PIN 23300) | |
| 56650-2 | -12 | | |
| 55780 | N/A | | |
| 55782 | N/A | | |
| 55791 | N/A | | |
| 55793 | N/A | | |

A

B

C

STYLE

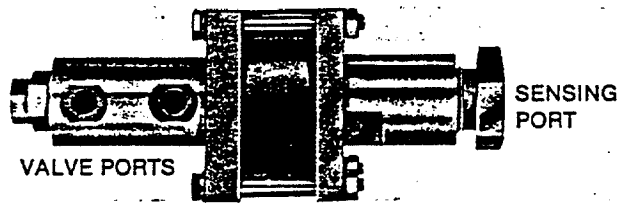
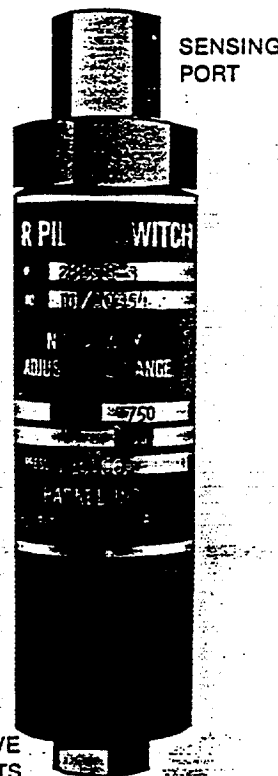
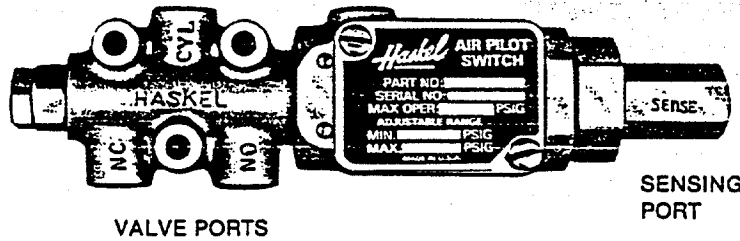

NOTES:

- (1) FETY: When using N.O. models to limit pump output pressure, also include a backup relief valve (ref. schematics 1, 3, 5, 6, pages 4 and 5.)
- (2) AIR VALVE: Materials are Aluminum, Stainless Steel, Bronze, and Buna suitable for air and most gases. Modification available for sour natural gas to meet NACE SPEC. MR-01-75.

Selection Chart

| MAXIMUM SENSING PRESSURE PSI | AIR VALVE | ADJUSTABLE RANGE PSI FACTORY SETTING AT NO CHARGE (Specify if Increasing or Decreasing) | | APPROXIMATE DIMENSIONS (INCHES) | | PORTS | |
|---------------------------------|---|---|---|---------------------------------|--------------|-----------------------------------|--------------------|
| | | NORMALLY OPEN | NORMALLY CLOSED | LENGTH | OUTSIDE DIA. | AIR (2) | SENSING (3) |
| 10,000 Standard 5,000 Oxygen | (1) | 2,000-10,000 700-4,400 200-950 | 3,500-10,000 1,200-4,800 500-1,300 | 8 | | | 1/4 NPT |
| 25,000 | 3 Way May be piped N.C. or N.O. or 2 Way N.C. or N.O. | 6,000-11,000 8,000-25,000 3,000-8,500 | 7,000-12,000 10,000-25,000 4,000-9,500 | 8-5/8 | 2 | 1/8 NPT | 1/4 Super-pressure |
| 10,000 Standard 5,000 Oxygen | (1) | 60-240 150-1,050 280-1,250 | 150-300 225-1,200 500-1,400 | 7-5/8 | | | 1/4 NPT |
| 600 | | 16-50 40-190 | 25-62 62-200 | 8-3/8 | 2-1/8 | | |
| 10,000 Standard 5,000 Oxygen | 3 Way N.C. | | 1,500-10,000 300-3,500 150-700 | 5-11/16 | | 1/8 NPT (Vent not Threaded) | |
| | (1) 2 Way N.O. | 2,500-10,000 750-4,000 250-750 2,000-8,500 | | 6-1/8 | 1-3/8 | 1/4 NPT Out 1/8 NPT In | 1/4 NPT |
| | 2 Way N.C. | | 1,000-10,000 250-4,250 140-750 600-6,500 | 5-11/16 | | 1/8 NPT | |
| 25,000 | 3 Way N.C. 2 Way N.C. | | 6,000-25,000 | 8 | | 1/8 NPT (Vent not Threaded) | |
| 60,000 (Intermittent) | 3 Way N.C. 2 Way N.C. | | 20,000-60,000 | 8 | 2 | | 1/4 Super-pressure |
| 25,000 | (1) 2 Way N.O. | 6,000-25,000 | | 8 | | 1/4 NPT Out 1/8 NPT In | |
| 60,000 (Intermittent) | | 20,000-60,000 | | | | | |
| 600 | 3 Way N.C. | | 12-37 17-200 | 6-1/2 | | 1/8 NPT (Vent not Threaded) | |
| | Pipe either (1) 3 Way N.C. or 2 Way N.O. | 13-47 28-200 | 13-47 28-200 | 7 | 2-1/8 | 1/4 NPT N.O. 1/8 NPT Others | 1/4 NPT |
| 10,000 Standard 5,000 Oxygen | 3 Way N.C. | | 50-180 110-900 | 6-5/16 | 1-3/8 | 1/8 NPT (Vent not Threaded) | |
| 10,000 | (1) | 2,500-10,000 with 20-100 Dome Load, Nominal Ratio 110:1 | | 7-1/2 | | | 1/4 NPT |
| 25,000 | 3 Way May be piped N.C. or N.O. or 2 Way N.C. or N.O. | 4,500-23,400 with 20-100 Dome Load, Nominal Ratio 245:1 | | 8-3/4 | 4-1/4 | 1/8 NPT | 1/4 Super-pressure |
| 10,000 | | 600-2,700 with 20-100 Dome Load, Nominal Ratio 28:1 | | 7 | | | 1/4 NPT |
| 600 | | 135-530 with 20-100 Dome Load, Nominal Ratio 6:1 | | 7-1/2 | | | |

(3) SENSING SECTIONS: Materials are Stainless Steel, PTFE, Buna (with Viton or Silicone for Oxygen) suitable for most liquids or gases. Modifications available for sour natural gas and fire resistant hydraulic fluids.

CONVENIENT CONVERSIONS: PRESSURE: 1 BAR = 14.5 PSI = 100 KPa = 1.02 KG/CM², 1 MPa = 10 BAR • VOLUME: 1 LITRE = 61 CU. IN., 1NM³ = 35.3 SCF, 1 SCF = 28.32NL
LENGTH: 1 INCH = 25.4 MM • WEIGHT: 1 KG = 2.2 LBS. • POWER: 1 HP = .746 KW.

| | | | | | | |
|-------|----------|---|---|---|---|---------------------------|
| ISSUE | 0 | 1 | 2 | 3 | 4 | PAGE 1 OF 1 |
| DATE | 05SEPT94 | | | | | NETZSCH JOB 401-880/95 |

| | | |
|--------------|-----------------------------|----------|
| NETZSCH INC. | FILTRATION SYSTEM COMPONENT | DWG. NO. |
| EXTON, PA. | SPECIFICATION | N/A |

CUSTOMER: OHM REMEDIATION SERVICES

PROJECT NO: OU NO. 2 MCB CAMP LEJEUNE

SPECIFICATION:

| |
|----------------------|
| FILTER PLATES |
|----------------------|

QTY. (17) Intermediates, (1) Head, (1) End, (1) Blankout

Type: Polypropylene Recess Chamber

Cake Volume: 0.34 ft³/ chamber

Filter Area: 5.85 ft²/ chamber

Cake Thick: 32MM (1.25in)

Plate Size: 630MM X 630MM (24" x 24")

NIL P/N

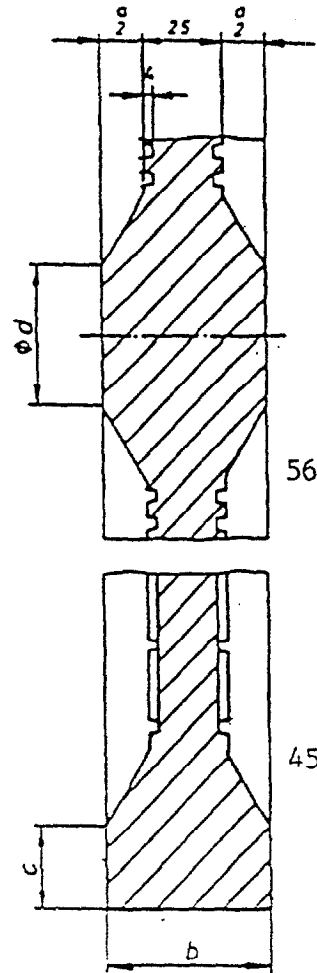
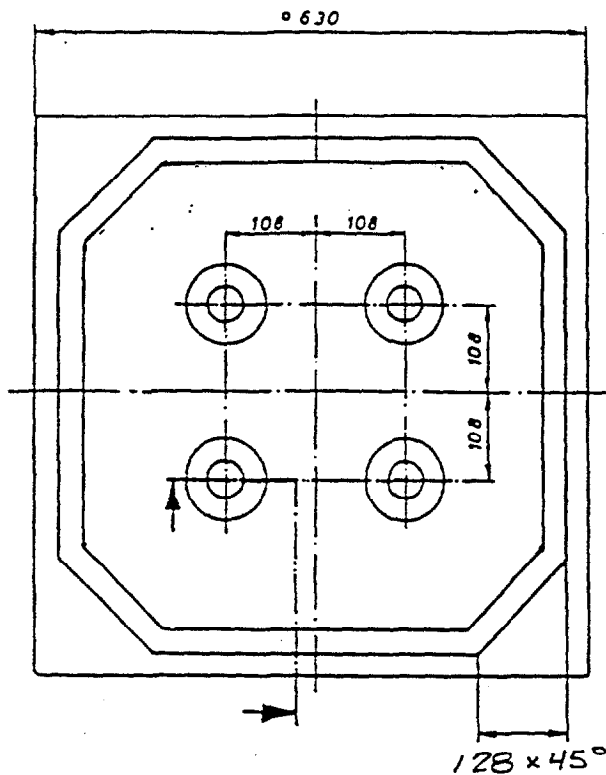

| Cake Thickness a | Plate Thickness b | | Sealing Edge c | Distance Support Diameter d | Filter Area m ² | Volume Liter | Weight KG |
|---------------------|-------------------|----------------|-------------------|--------------------------------|-------------------------------|-----------------|--------------|
| | Chamber Plate | Head & End Plt | | | | | |
| 15 | 40 | 47.5 | 47.5 | 40.5 | 0.507 | 3.65 | 10.6 |
| 20 | 45 | 50 | 45 | 37.5 | 0.518 | 4.91 | 11.3 |
| 25 | 50 | 52.5 | 42.5 | 34 | 0.529 | 6.19 | 11.9 |
| 30 | 55 | 55 | 40 | 30.5 | 0.539 | 7.50 | 12.5 |
| 32 | 57 | 56 | 39 | 29 | 0.544 | 8.02 | 12.7 |
| 35 | 60 | 57.5 | 37.5 | 27 | 0.550 | 8.82 | 13.0 |
| 38 | 63 | 59 | 36 | 25 | 0.557 | 9.63 | 13.4 |
| | | | | | | | |
| | | | | | | | |
| | | | | | | | |

Chamberplate of PP K 0630 C/16



1750 Oak Street, Lakewood, NJ 08701
 Telephone: (908) 370-1600
 Telefax: (908) 370-8411

| | | | | | | |
|-------|----------|---|---|---|---|------------------------------|
| ISSUE | 0 | 1 | 2 | 3 | 4 | PAGE <u>1</u> OF <u>1</u> |
| DATE | 05SEPT94 | | | | | NETZSCH JOB 401-880/95 |

| | | |
|--------------|-----------------------------|----------|
| NETZSCH INC. | FILTRATION SYSTEM COMPONENT | DWG. NO. |
| EXTON, PA. | SPECIFICATION | N/A |

CUSTOMER: OHM REMEDIATION SERVICES

PROJECT NO: OU NO. 2 MCB CAMP LEJEUNE

SPECIFICATION:

| |
|----------------------|
| FILTER CLOTHS |
|----------------------|

QTY. TWO (2) sets

Type: Polypropylene

Style: 40X

Weave: 5H Sateen

Wt./Sq. Yd.: 9

Porosity: 3 to 5 CFM

DESCRIPTION: *Two (2) sets of polypropylene filter cloths shall be provided to cover each filter plate on both sides. End plates shall have cloths on one side only. The plate side sealing surface shall be coated with latex paint to minimize wicking during operation. The filter cloths shall include a neoprene center barrel neck. The filter cloths material shall be of sateen weave construction (Mono-Multi, Filament). Red high strength plastic ties; standard type grommets will be used to secure the cloths to the plates.*

NIL P/N

| | | | | | | |
|-------|---------|---|---|---|---|---------------------------|
| ISSUE | 0 | 1 | 2 | 3 | 4 | PAGE 1 OF 1 |
| DATE | 05MAY95 | | | | | NETZSCH JOB 401-880/95 |

| | | |
|--------------|-----------------------------|----------|
| NETZSCH INC. | FILTRATION SYSTEM COMPONENT | DWG. NO. |
| EXTON, PA. | SPECIFICATION | |

CUSTOMER: OHM Remediation Services

FILTER PRESS " AIR DIAPHRAGM " FEED PUMP SYSTEM

QTY. 1 P-141

One (1) skid mounted sludge feed system with one (1) air diaphragm pump with interconnecting piping between the pump discharge and filter press inlet. The pump specifications are listed below:

Model: M4 Wilden

Type: WO/PU/NE/NE

Capacity: 15.0 GPM REQUIRED (based on water; ambient temperature)
Maximum discharge pressure up to 100 psi

Material of Construction

- Wetted Parts: Cast Iron
- Non Wetted Parts: Cast Iron
- Diaphragm: Polyurethane
- Ball Valve: Neoprene
- Filter-Regulator-Lubricator:

Accessories:

One (1) air actuated control system. An On/Off selector switch is located on the filter press traverse to control the air diaphragm feed pump. The air piping is supplied by Netzsch Inc.

The customer is responsible to supply compressed air at the air diaphragm pump connection (10cfm, 100psig compressed air required) ref: Netzsch Drwg: C41170510

IF IT POURS IT PUMPS

DIRECTIONS FOR INSTALLATION AND MAINTENANCE

WILDEN MODEL M4

MODELS M4/OO, BO, SO, HO, WO, SW, HW, WW,
TO, BT, ST, SY, HT, HY

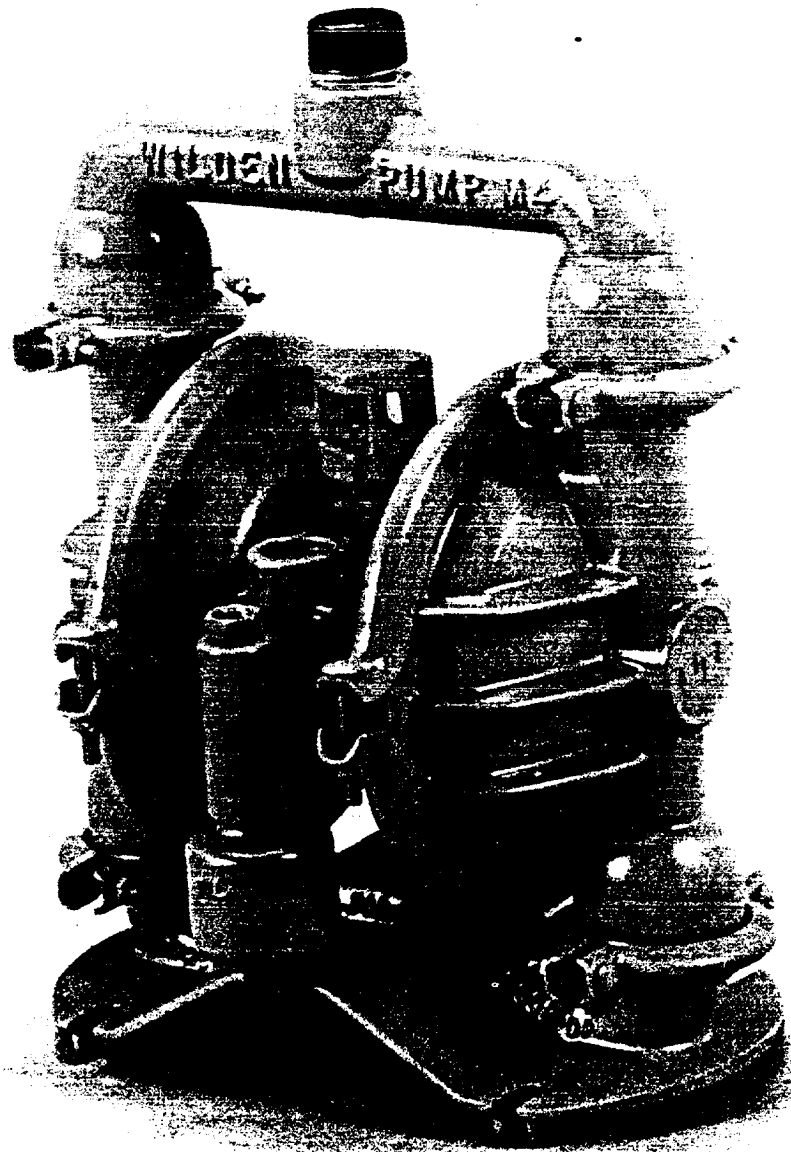

SPECIFICATIONS AND PERFORMANCE

M4

WILDEN® MODEL M4®

Height 18"
 Width 14¼"
 Depth 11¼"
 Weight ALUMINUM 35 lbs.
 IRON OR STAINLESS 52 lbs.
 Air Inlet ¾" N.P.T.
 Inlet 1½" Female N.P.T.
 Outlet 1¼" Male N.P.T.
 Suction Lift 22' Dry
 27' Wet
 Max. Size Solids 3/16" Dia.
Example: To pump 22.5 gpm against a discharge pressure head of 45 psig, requires 60 psig and 20 scfm air consumption. (See dot on chart.)

Note: For M4 pumps fitted with Teflon diaphragms reduce water discharge figures by 20%. Suction lift for M4 pumps with Teflon diaphragms: 12 ft. dry, 25 ft. wet.

Caution: Do not exceed 125 psig air supply pressure.

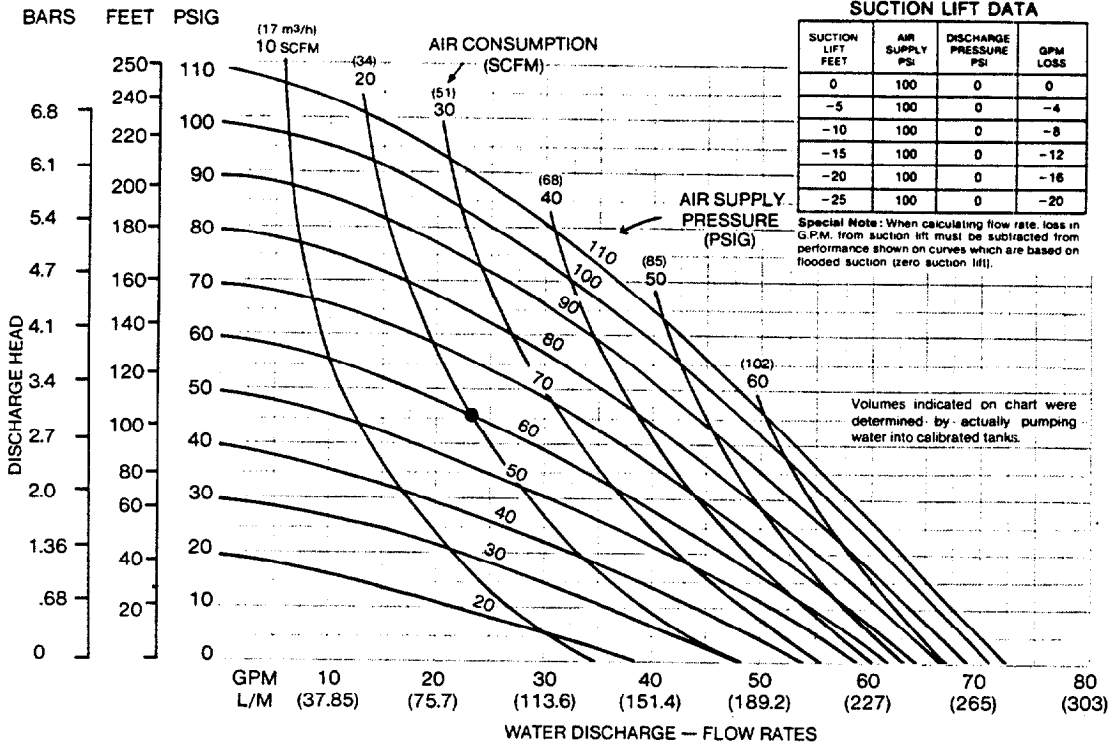

CERTIFIED DIMENSION DRAWING MODEL M4

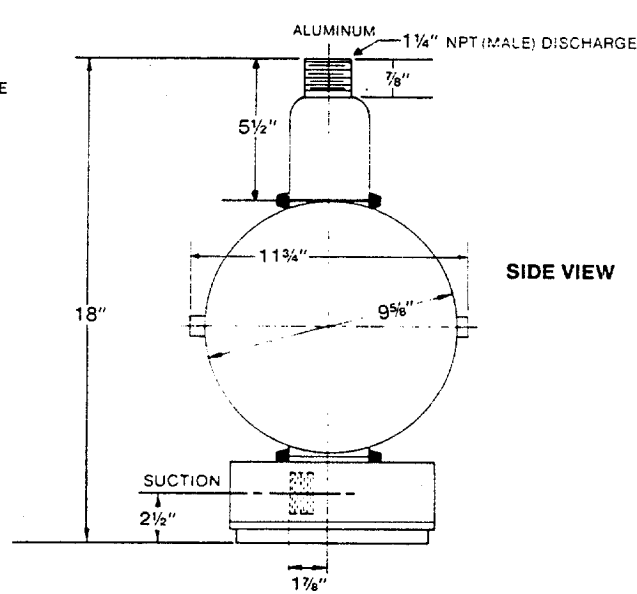
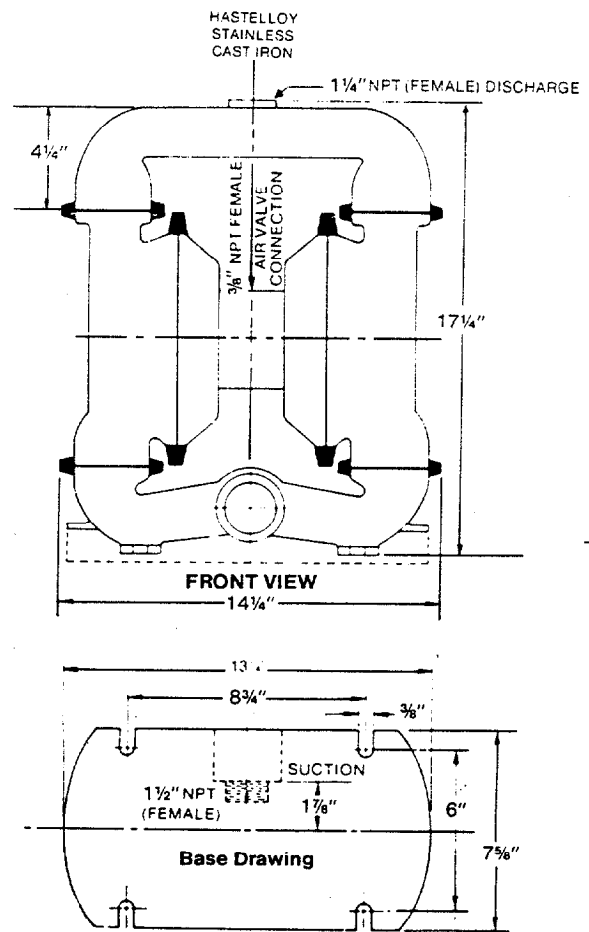

NOTE: THE CONFIGURATION OF THE INLET MANIFOLD IS FOR ALUMINUM AND CAST IRON MODELS. STAINLESS STEEL AND HASTELLOY MODELS HAVE A DIFFERENT FOOTED INLET MANIFOLD, BUT WITH THE SAME BOLT PATTERN AND DIMENSIONS AS SHOWN HERE.

WILDEN PUMP & ENGINEERING CO.
 22069 Van Buren Street, Colton, California 92324
 Phone: (714) 783-0621
 Telex 676-452

NOTE: SUCTION AND DISCHARGE NIPPLES ON STANDARD ALUMINUM PUMPS ARE MILD STEEL AND ON ALLOY-FITTED ALUMINUM PUMPS ARE STAINLESS

SECTION I

WILDEN PUMP INSTALLATION / OPERATION INSTRUCTIONS

INSTALLATION

The model M-4 pump comes standard with a footed inlet housing/base combination. For permanent self-priming installations bolt the inlet housing directly to a mounting pad. For submersible applications the M-4 aluminum or cast iron pumps can be ordered with an optional aluminum screen which attaches to its inlet housing. If the pump is to be used in a permanently submerged application, a hose should be attached to the pump *air* exhaust and the exhaust air piped through the liquid level to prevent the liquid from entering the pump. **Caution:** All models have non-wetted parts of aluminum/brass/steel or cast iron/brass/steel and, therefore, can only be used as submersible pumps in non-corrosive materials.

In permanent installations the pump should be attached to the plant piping through a flexible coupling both the intake and discharge side to reduce pipe vibration due to the reciprocating nature of the pump. To further reduce vibration, a surge suppressor next to the pump discharge may be used.

The M-4 pump has a 1-1/4" discharge and a 1-1/2" intake opening. The standard aluminum model has a cast in mild steel NPT threaded male fitting on the discharge opening and a mild steel cast in NPT threaded in female fitting in the inlet opening. The alloy-fitted models have cast-in nipples of stainless steel. The M-4 cast iron, stainless steel and Hastelloy "C" models have a tapped female thread in the inlet and discharge openings. *Note: Do not attempt to remove intake or discharge fittings.

Suction pipe size should be at least 1 1/2" diameter, larger if highly viscous material is to be pumped. If suction hose is used it should be of a non-collapsing reinforced type as the M-4 is capable of pulling a vacuum. Discharge piping should be at least 1-1/4". It is critical, especially on the suction side of the pump, that all fittings and connections are air tight or a reduction or loss of pump suction capability will result.

THE M-4 PUMP WILL PASS 3/16" DIAMETER SOLIDS.

WHENEVER THE POSSIBILITY EXISTS THAT LARGER SOLID OBJECTS MAY BE SUCKED INTO THE PUMP, A STRAINER SHOULD BE USED ON THE SUCTION LINE.

The inlet to the air valve is 3/8" NPT. The compressed air line to the pump should be 1/2". The air line should be large enough to supply the volume of air necessary to achieve the desired pumping rate (see M-4 pump performance curve). Use air pressure up to 110 psig, depending upon pumping requirements.

CAUTION: DO NOT EXCEED 125 PSIG AIR SUPPLY PRESSURE.

Pump discharge rate can be controlled by:

1. Limiting the volume and/or pressure of the air supply to the pump (preferred method). The use of a gate valve or needle valve installed at the air inlet to the pump is suggested for this purpose.
2. Throttling the pump discharge by means of a valve when the need to control the pump from a remote location exists. When the pump discharge pressure equals the air supply pressure, the pump will stall out, no bypass or pressure relief valve is needed and pump damage will not occur.

Sound level can be reduced below 90 decibels by attaching our optional muffler at pump air exhaust port.

OPERATING INSTRUCTIONS

A. The model M-4 comes with a built in oil reservoir. This should be kept filled with a 10 weight motor oil. If the pump is placed in a permanent installation, the use of an air line oil lubricator is suggested. No alterations should be made to the pump. In cold weather operation the air valve may freeze due to moisture in the air line. If this occurs the use of ethylene glycol type antifreeze or other de-icer such as Tannergas can be substituted for the 10 weight oil.

B. Make sure air line to pump is free from dirt or other foreign matter. The air valve screen, P/N 60E, (see air valve diagram, pg. 8) will generally collect any particles too large to pass through the pump's air system. If pump performance drops off, check this screen for clogging.

C. Turn on air supply to pump. CAUTION: Make sure air supply pressure to pump does not exceed 125 psig. If it does a pressure regulator should be installed and set at a maximum of 125 psig.

D. Pumping volume (gpm) can be set by counting the number of strokes per minute. The M-4 pumps approximately .31 gallons per stroke. A stroke is 1/2 cycle or one air exhaust.

When pump is used for moving thick materials check stroke rate to determine that pump is not operating at a faster rate than material is capable of flowing, or cavitation will occur. If pump is operating at a speed too fast for available flow, reduce the volume of air to the pump until stroke rate approximates discharge volume.

E. Always flush pump after use if material being pumped will pack or solidify. The pump can be turned upside down and all liquid will drain out.

F. For pumps fitted with Teflon diaphragms, limit suction inlet pressure to 10 psig maximum.

NOTE: Temperature range on Teflon diaphragm is +40°F to 220°F.

TROUBLE SHOOTING

Pump will not run or runs slowly

1. Check air inlet screen for dirt.
2. Check for sticking air valve, flush air valve in solvent.
3. Check for worn out air valve. If piston face in air valve is shiny instead of dull, air valve is probably worn beyond working tolerances and must be rebuilt by Wilden or replaced.
4. Check center block O-rings. If worn excessively they will not seal and air will simply flow through pump and out air exhaust. Use only Wilden O-rings as they are of special construction.

Pump runs but little or no product flows

1. Check pump cavitation, slow pump speed down to match thickness of material being pumped.
2. Check for sticking ball checks. If material being pumped is not compatible with pump elastomers, swelling may occur. Replace ball checks and seats with proper elastomers.
3. Check to make sure all suction connections are air tight, especially clamp bands around intake balls.

Pump air valve freezes

Check for excessive moisture in compressed air. Either install dryer for compressed air or use an anti-freeze such as Tannergas or Killfrost in lieu of SAE 10W oil.

Air bubbles in pump discharge

1. Check for ruptured diaphragm.
2. Check tightness of clamp bands, especially at intake manifold.

Product comes out air exhaust

1. Check for ruptured diaphragm.
2. Check tightness of piston plates to shaft.
3. Insure Piston O-ring is in place, if required on Model involved.

CAUTION: WEAR SAFETY GLASSES, WHEN DIAPHRAGM FAILURE OCCURS, MATERIAL BEING PUMPED MAY BE FORCED OUT AIR EXHAUST.

SECTION II

DISASSEMBLY / REASSEMBLY INSTRUCTIONS

CAUTION: Before any maintenance or repair is attempted, the compressed air line to the pump should be disconnected and all air pressure allowed to bleed from pump. Disconnect all intake, discharge, and air lines. Drain the pump by turning it upside down and allowing any fluid to flow into a suitable container.

The Wilden M-4 has a 1-1/2" inlet and 1-1/4" outlet and is designed for flows up to 73 GPM. Its air distribution system is based on design simplicity and proven efficiency. The model M-4 is available in aluminum, cast iron, 316 stainless steel, or Hastelloy "C" wetted parts. The aluminum model features die-cast water chambers, which allow for streamlined contours, while reducing friction of fluid flow.

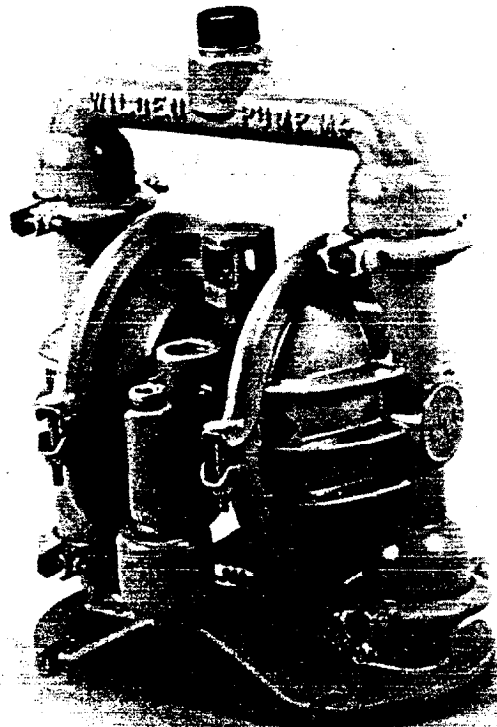

NOTE: Before starting disassembly, mark a line from each liquid chamber to its corresponding air chamber. This line will assist in proper alignment during reassembly.

DISASSEMBLY: Step 1

NOTE: Model used for these instructions incorporates rubber diaphragms, balls, and seats. Models with Teflon diaphragms, balls and seats are the same except where noted.

Start by removing the two clamp bands that fasten the discharge manifold to the main body of the pump. (Figures 1A & 1B)

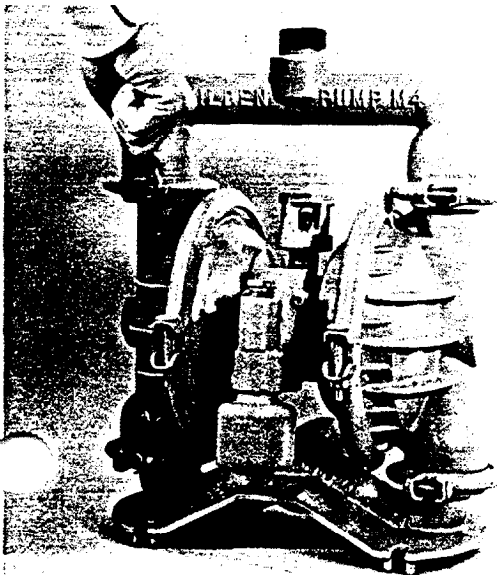

Figure 1A

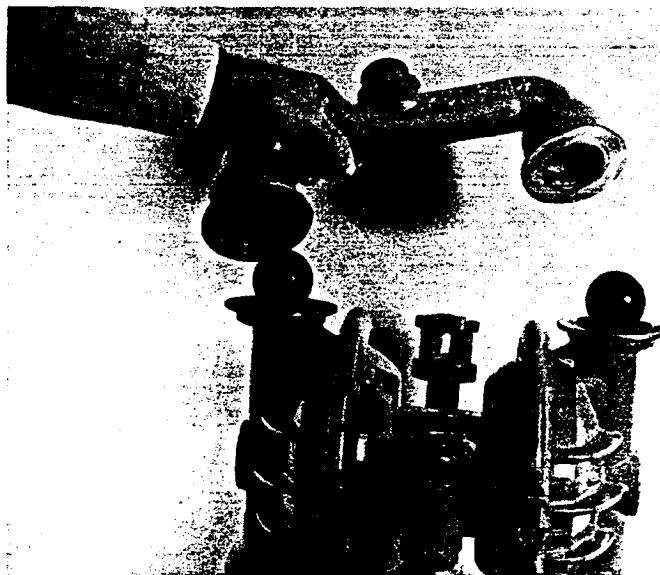

Figure 1B 3

STEP 2

Remove the two clamp bands that hold the inlet manifold to the main body of the pump. Lift the main body of the pump from the inlet manifold and set it to one side. The inlet ball valves, and seats are now available for examination. (See *Figure 2A*) Next, remove large clamp bands which attach water chamber to the center section of the pump. (See *Figure 2B*)

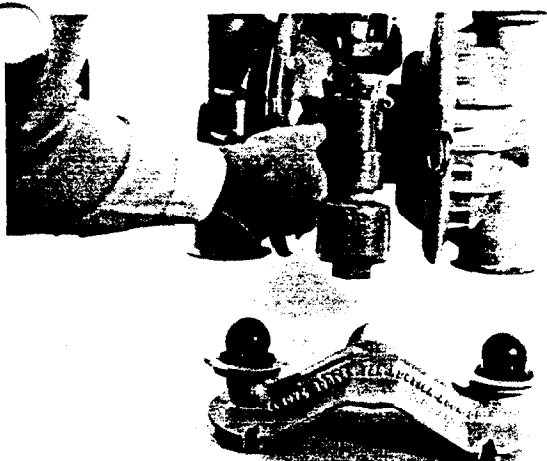

Figure 2A

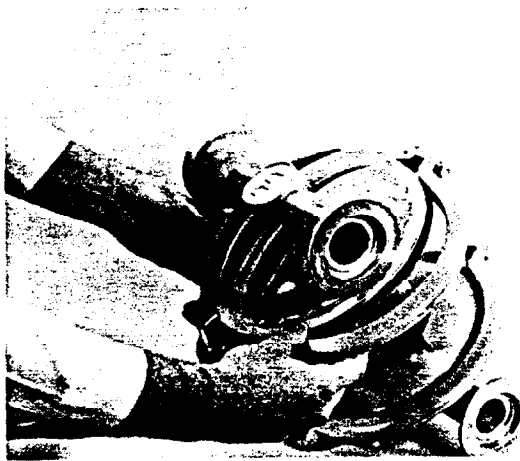

Figure 2B

Remove only one liquid chamber from the center section. This will expose the diaphragm and its piston plate. (See *Figure 2C*) The diaphragm and the piston plate can be removed by unscrewing them from the connecting shaft with an adjustable wrench. The opposite diaphragm will be held tight by the opposite liquid chamber. (See *Figure 2D*)



Figure 2C

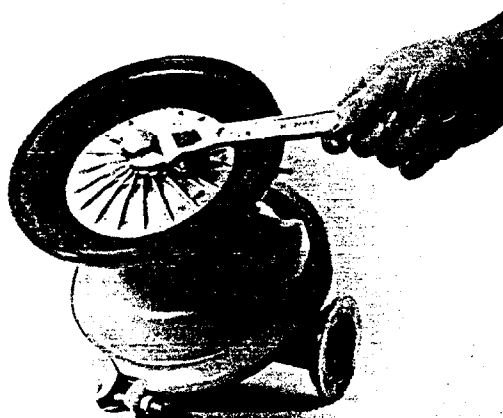

Figure 2D

Now remove the opposite liquid chamber. The second diaphragm is now available for inspection and cleaning. (See *Figure 2E*) If the second diaphragm is to be removed, it is **important not to score or mark the chrome-plated shaft**. A vise with wood blocks is suggested as a method of securing the shaft while removing the second diaphragm.



Figure 2E

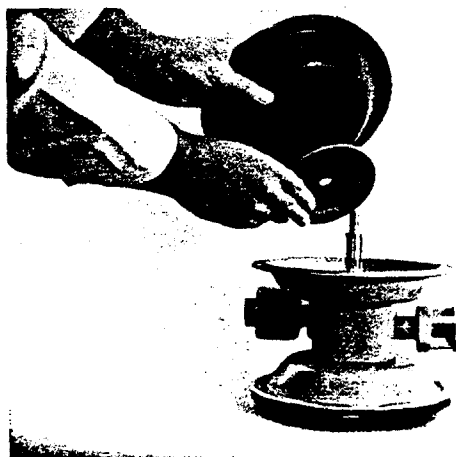
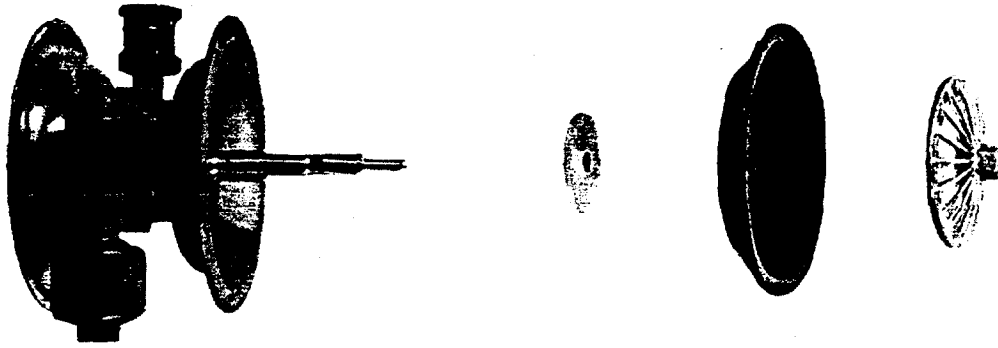

Figure 2F

Upon removing the diaphragms, the inner piston is now exposed and available for inspection. (See *Figure 2F*)

ASSEMBLY:



STEP 1 (RUBBER DIAPHRAGMS)

Exploded View Figure 3A

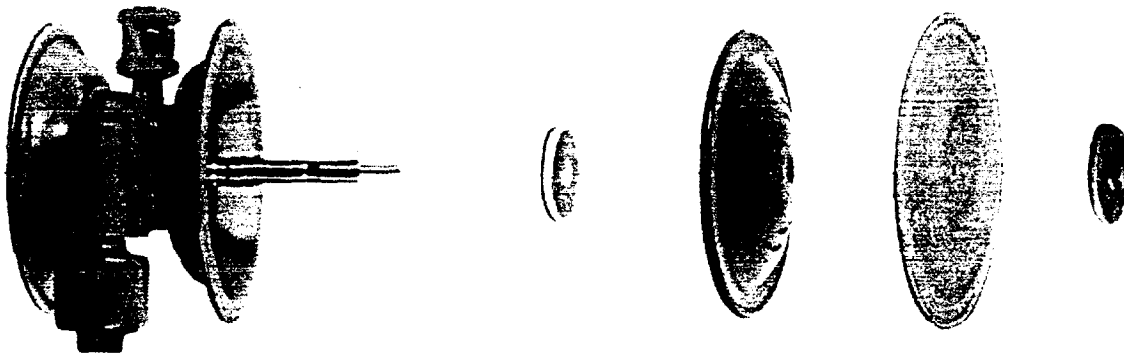

(TEFLON DIAPHRAGMS)

Exploded View Figure 3B

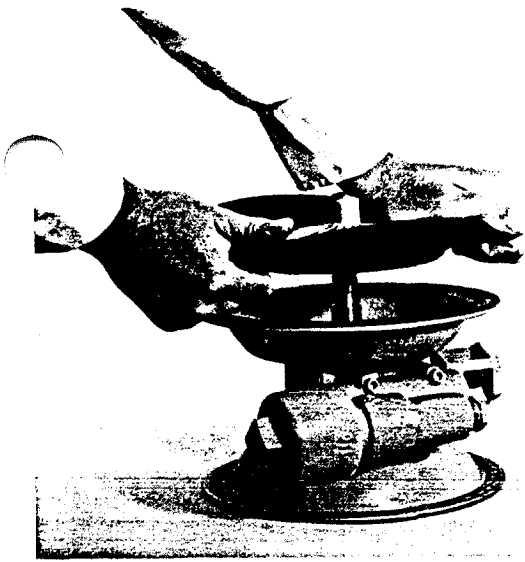

Figure 4A

STEP 2

To install shaft, push shaft firmly through the bushing in the center block. Be sure to lubricate bushing with 10W oil so that shaft may pass by the O-rings. (See *Figure 4A*) Next, tighten outer piston securely to diaphragm assembly. (See *Figure 4B*) Once opposite water chamber is attached to center section, place center section on its side and push second diaphragm assembly toward the lip of the air chamber until the outer bead of the diaphragm rests within this groove. (See *Figure 4C*) The outer clamp band can now be secured, and center section can be placed over the inlet manifold. Be sure to observe the previously made alignment marks. (See *Figures 4D* and *4E*) **Note: When installing Teflon diaphragms, it is important to tighten outer pistons simultaneously (turning in opposite direction) to ensure a tight, secure fit.**

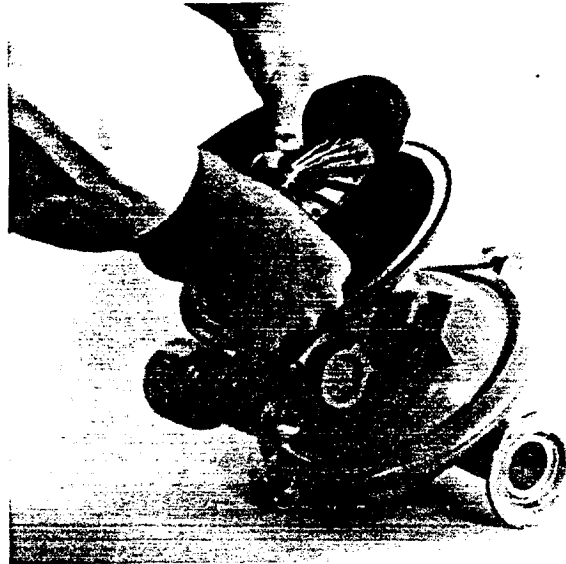

Figure 4B

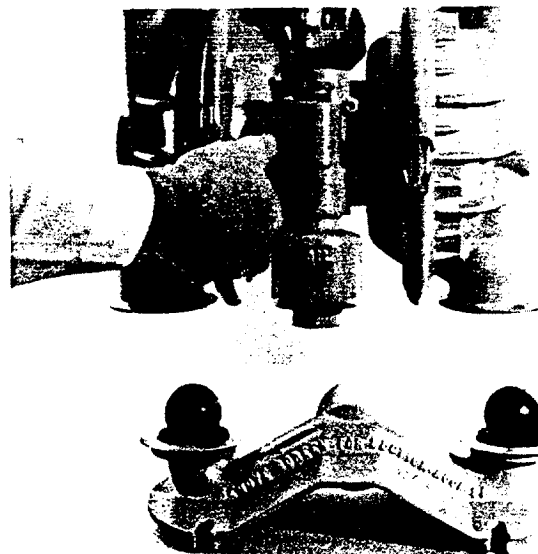

Figure 4C

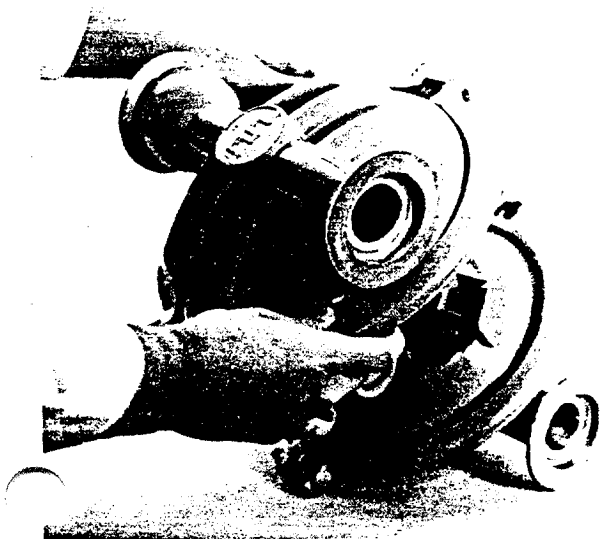

Figure 4D

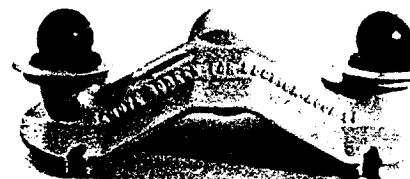

Figure 4E

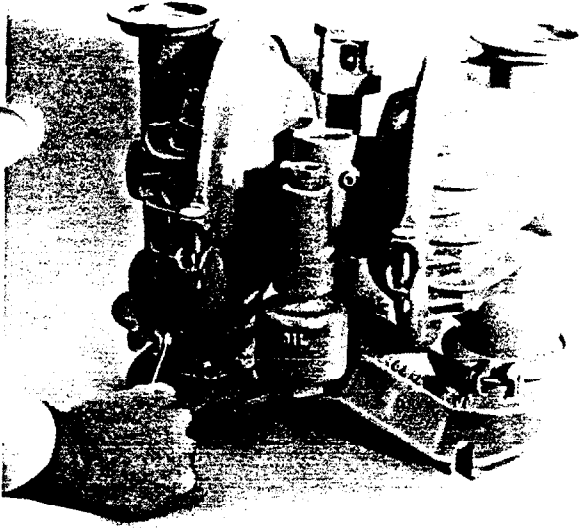

Figure 4F

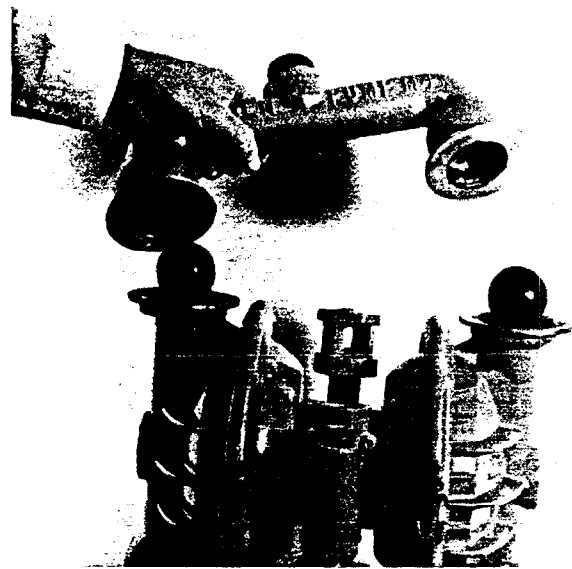

Figure 4G

Next, securely tighten small clamp bands around inlet manifold & water chambers. (See *Figure 4F*) Finally, place discharge manifold over assembled center section (See *Figure 4G*) & secure small clamp bands.

NOTES:

SECTION III

AIR VALVE / CENTER BLOCK DISASSEMBLY / REASSEMBLY

The air valve assembly consists of both the air valve body and piston and the center block. The unique design of the air valve relies only on differential pressure to effect the diaphragm shift. It is reliable and simple to maintain. The bushing in the center block, along with the diaphragm shaft, provides the "trigger" to tell the air valve to shift. The following procedure will ensure that the air valve on your Wilden pump will provide long trouble-free service.

AIR VALVE BODY AND PISTON ASSEMBLY AND DISASSEMBLY:

The air valve body and piston (P/N 60A), can be disconnected from the pump by removing the four socket head cap screws (P/N 60AS), which attach it to the center block. The piston in the air valve is aluminum with a dark gray anodized coating. The piston should move freely and the ports on the face of the air valve body (see below). The piston should also appear to be dull, dark gray in color. If the piston appears to be a shiny aluminum color, the air valve is probably worn beyond working tolerances and should be either replaced or returned to the Wilden distributor for rebuild.

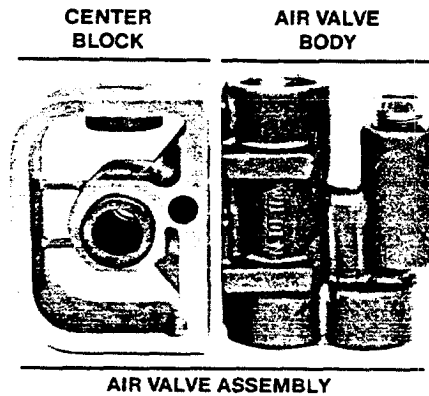

Figure A

If the piston does not move freely in the air valve, the entire air valve should be immersed in a cleaning solution. [NOTE: Do not force the piston by inserting a metal object.] This soaking should remove any accumulation of sludge and grit which is preventing the air valve piston from moving freely. Also, remove and clean the air valve screen (P/N 60E). If the air valve piston does not move freely after the above cleaning, the air valve should be disassembled as follows: remove the snap ring from the top end of the air valve cylinder and apply an air jet to the 3/16-inch hole on the opposite end of the air valve face (see Figure C). **CAUTION:** The air valve end cap, may come out with considerable force. Inspect the piston and cylinder bore for nicks and scoring.

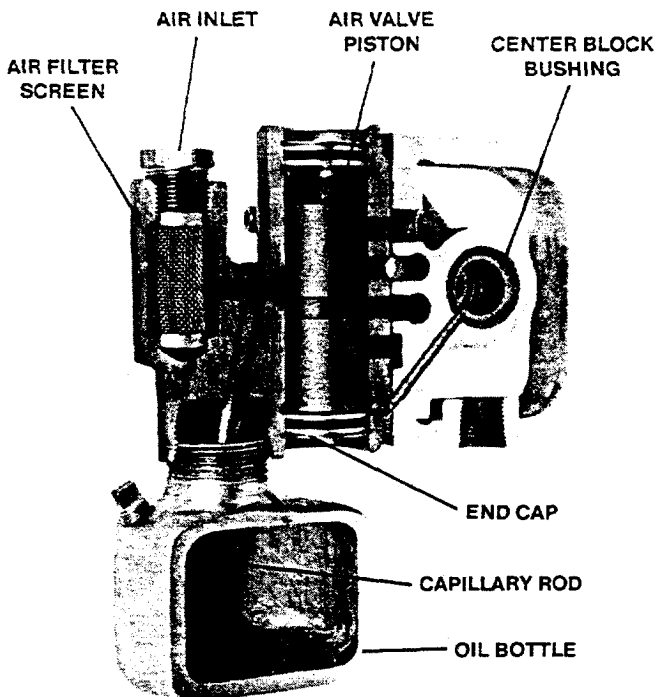

Figure B

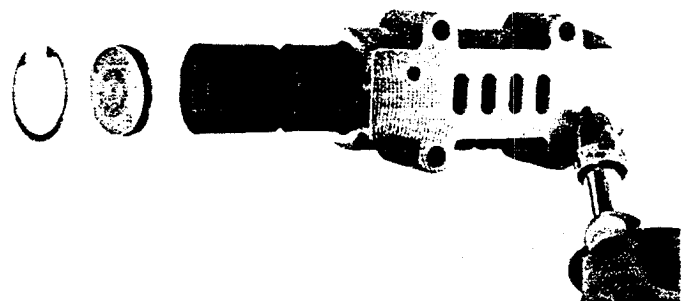

Figure C

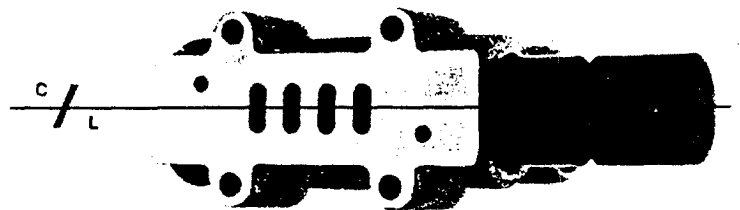

Figure D

Small nicks can usually be dressed out and the piston returned to service. The oil capillary rod should also be cleaned to ensure proper lubrication of the air valve. Inspect the cylinder end caps (P/N 60R has the piston guide pin and P/N 60S does not). Make sure that the guide pin is straight and smooth or the piston will not move freely in the cylinder. New O-rings (P/N 60U) should be installed on the end caps. Lubricate the O-rings and install the end caps, assuring that proper alignment of the piston and cylinder ports is maintained (see *Figure D*). Reinstall air valve to center block of pump.

O-RING REPLACEMENT:

When the O-rings become worn or flat, they will no longer seal and must be replaced. This is most easily accomplished by using a tool called an O-ring pick, available through most industrial supply companies.

CENTER BLOCK ASSEMBLY (P/N 60H):

The pump's center block (P/N 60H) consists of a die cast housing with a cast-in-bronze bushing. The bushing has eleven grooves cut on the inside diameter. There are seven O-rings that fit in these grooves (see *Figure E*). Since these O-rings form a part of the shifting function of the pump, it is necessary that they be located in the proper grooves. The bronze bushing is replaceable in cast iron center blocks only. When bushing wear becomes excessive, a new center block must be used.

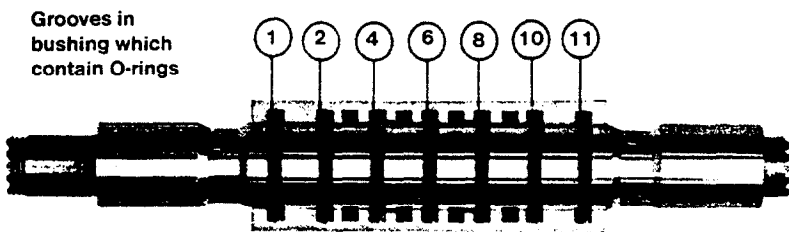

Figure E

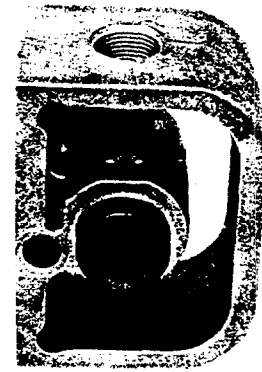

Figure F (Side View)

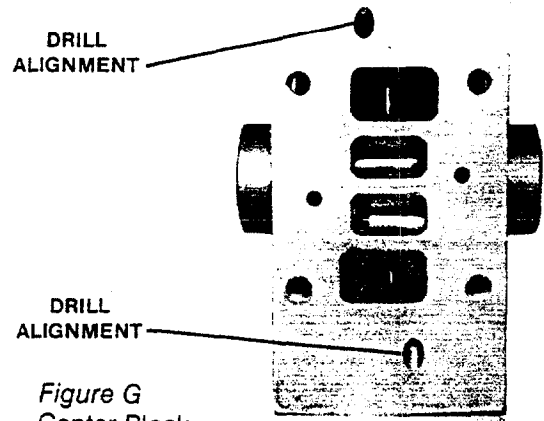
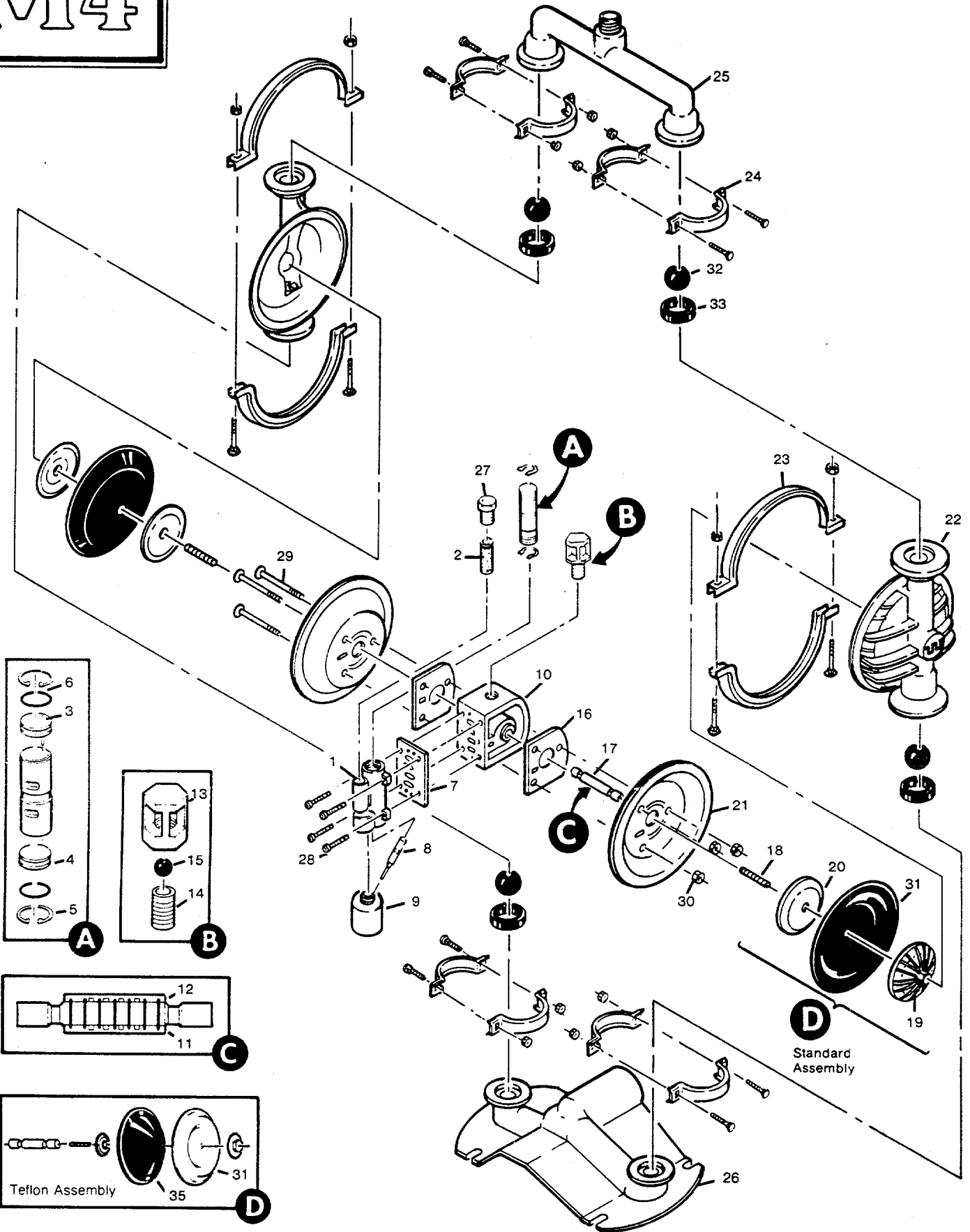

Figure G
Center Block
(Front View)

M4



NOTE: Teflon Diaphragm Models Assembled With Teflon Gasket Kit At Factory (Not Shown)

For Models M-4/OO/BO/WO/WW/WS/SO/SW/HO/HW

M-4 RUBBER FITTED

| Item | Description | Qty. Per Pump | M-4/OO | M-4/BO | M-4/WO | M-4/WW | M-4/WS | M-4/SO | M-4/SW | M-4/HO | M-4/HW |
|------|-----------------------------------|---------------|--------|--------|--------|--------|--------|--------|--------|--------|--------|
| | | | P/N | P/N | P/N | P/N | P/N | P/N | P/N | P/N | P/N |
| 1 | Air Valve Body & Piston | 1 | 60A | B60A | 60A | W60A | 60A | B60A | W60A | B60A | W60A |
| 2 | Air Valve Screen | 1 | 60E | | | | | | | | |
| 3 | Air Valve Cap w/Guide (Top) | 1 | 60R | | | 60RB | 60R | | 60RB | 60R | 60RB |
| 4 | Air Valve Cap wo/Guide (Bottom) | 1 | 60S | | | 60SB | 60S | | 60SB | 60S | 60SB |
| 5 | Snap Ring | 2 | 60T | S60T | 60T | S60T | 60T | S60T | | | |
| 6 | Air Valve Cap O-Ring | 2 | 60U | | | | | | | | |
| 7 | Air Valve Gasket | 1 | 60B | | | | | | | | |
| 8 | Lubricator Capillary Rod Assembly | 1 | 60C | | | | | | | | |
| 9 | Lubricator Oil Bottle | 1 | 60D | | | | | | | | |
| 10 | Center Block Assembly | 1 | 60H | | | W60H | 60H | | W60H | 60H | W60H |
| 11 | O-Ring | 7 | 20JH | | | | | | | | |
| 12 | Block Bushing | 1 | N/A | | | 60N | N/A | | 60N | N/A | 60N |
| 13 | Check Body | 1 | 20K8 | | | W20K8 | 20K8 | | W20K8 | 20K8 | W20K8 |
| 14 | Nipple | 1 | 20F | 20FS | 20F | | | 20FS | 20F | 20FS | 20F |
| 15 | Check Ball | 1 | 20M | | | | | | | | |
| 16 | Block Gasket | 2 | 60P | | | | | | | | |
| 17 | Shaft | 1 | 61A | | | | | | | | |
| 18 | Shaft Stud | 2 | T21F | | N/R | | | T61F | | | |
| 19 | Piston, Outer | 2 | B61B | | 61B | | | S61B | | H61B | |
| 20 | Piston, Inner | 2 | 61C | | | | | | | | |
| 21 | Air Chamber | 2 | 62 | | | | | | | | |
| 22 | Water Chamber | 2 | 65 | | W65 | | | S65 | | H65 | |
| 23 | Clamp Band (Large) | 2 | 64 | S64 | 64 | S64 | | | | | |
| 24 | Clamp Band (Small) | 4 | 69 | S69 | 69 | S69 | | | | | |
| 25 | Discharge Manifold | 1 | 66 | B66 | W66 | | | S66 | | H66 | |
| 26 | Inlet Housing | 1 | 67 | B67 | W67 | | | S67 | | H67 | |
| 27 | Reducer Bushing | 1 | 60AP | 70AP | 60AP | 70AP | 60AP | 70AP | | | |
| 28 | Air Valve Cap Screw | 4 | 60AS | 70AS | 60AS | 70AS | 60AS | 70AS | | | |
| 29 | Hex Head Cap Screw | 3 | 62B | | | | | | | | |
| 30 | Hex Head Nut | 3 | 62C | | | | | | | | |
| 31 | Diaphragm* | 2 | 63 | | | | | | | | |
| 32 | Valve Ball* | 4 | 71 | | | | | | | | |
| 33 | Valve Seat* | 4 | 70 | | | | | | | | |

*For optional elastomers, consult local distributor.

For Teflon fitted models see next page.

SECTION VII: DRAWINGS

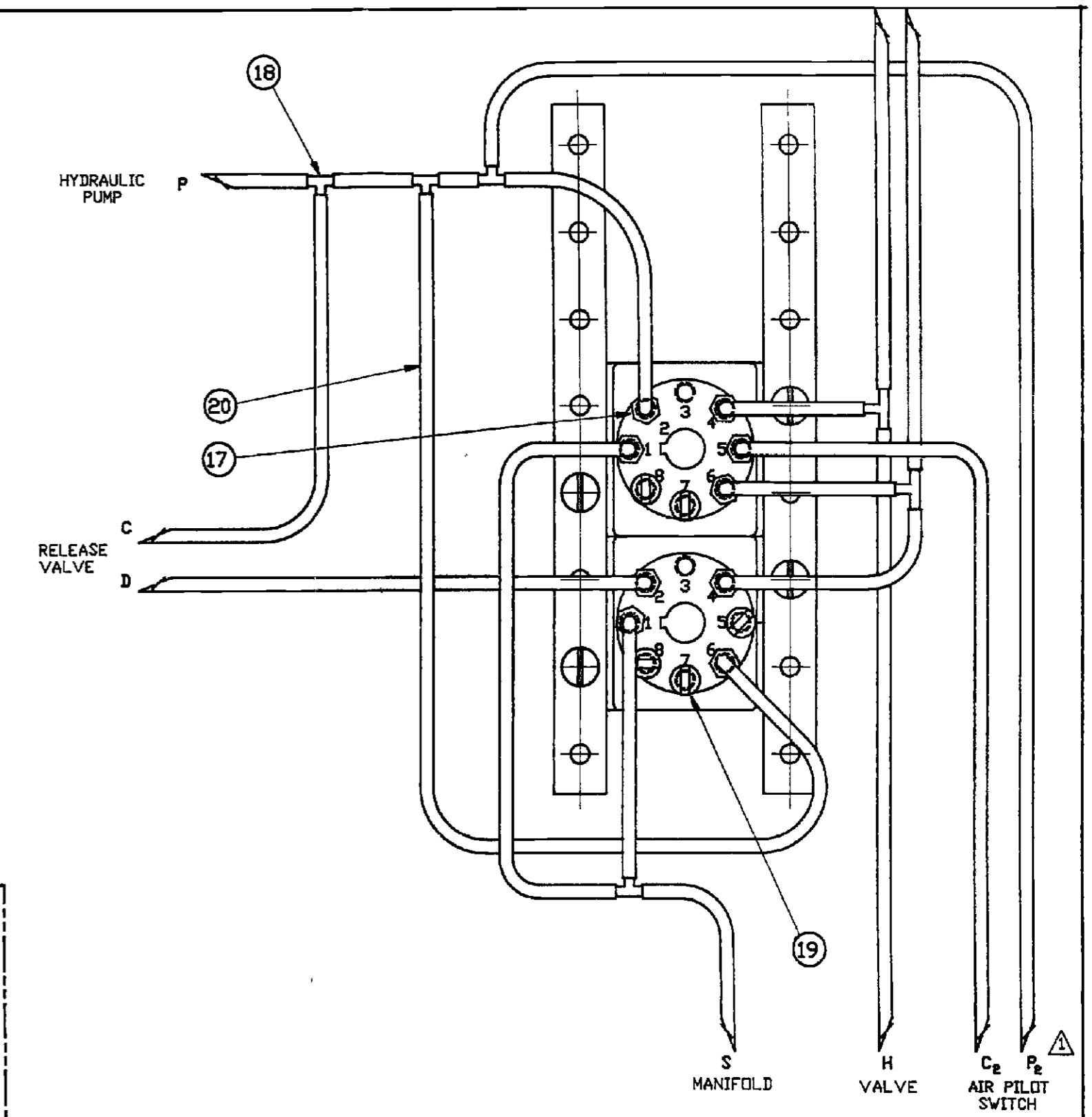
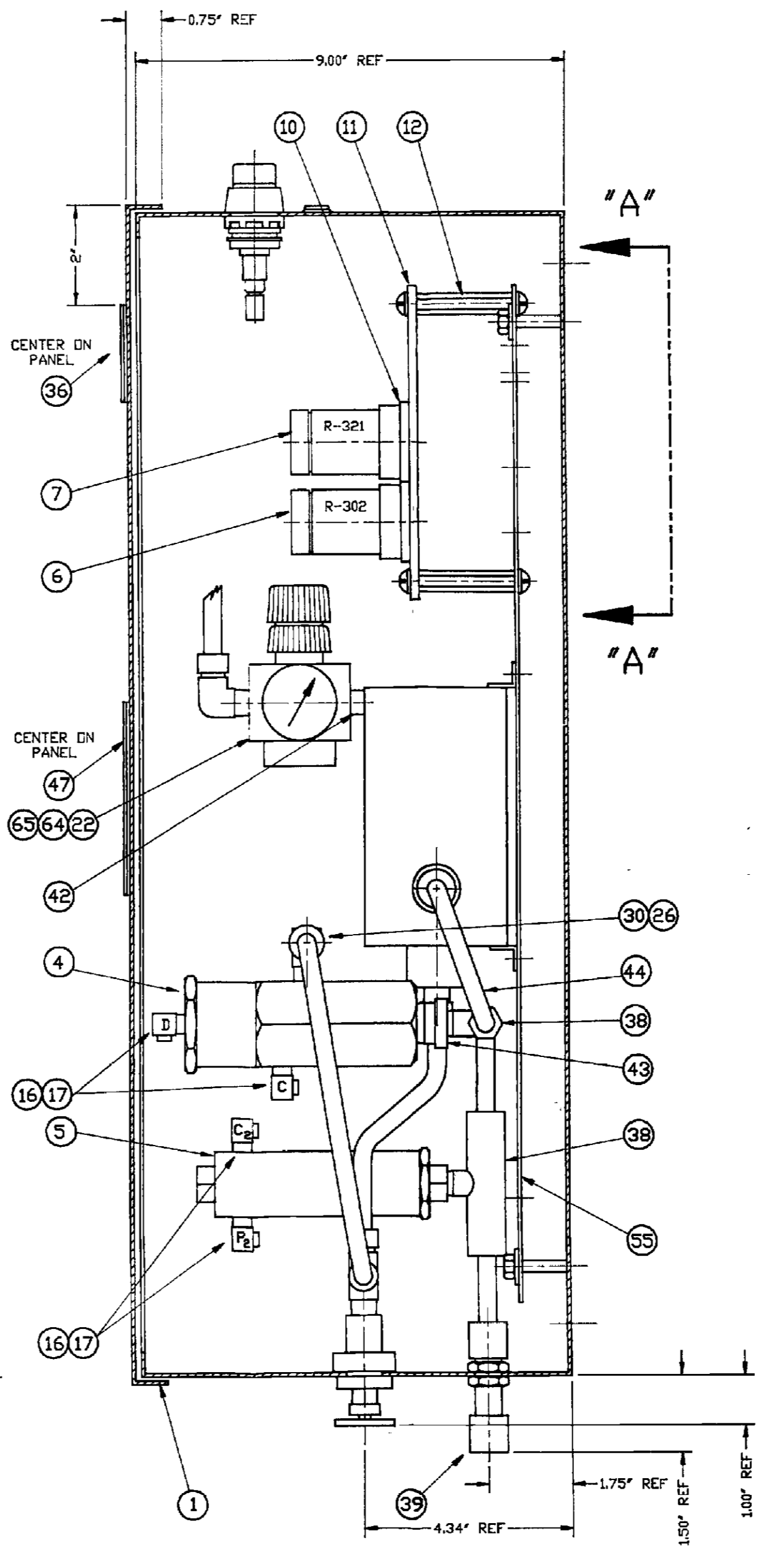
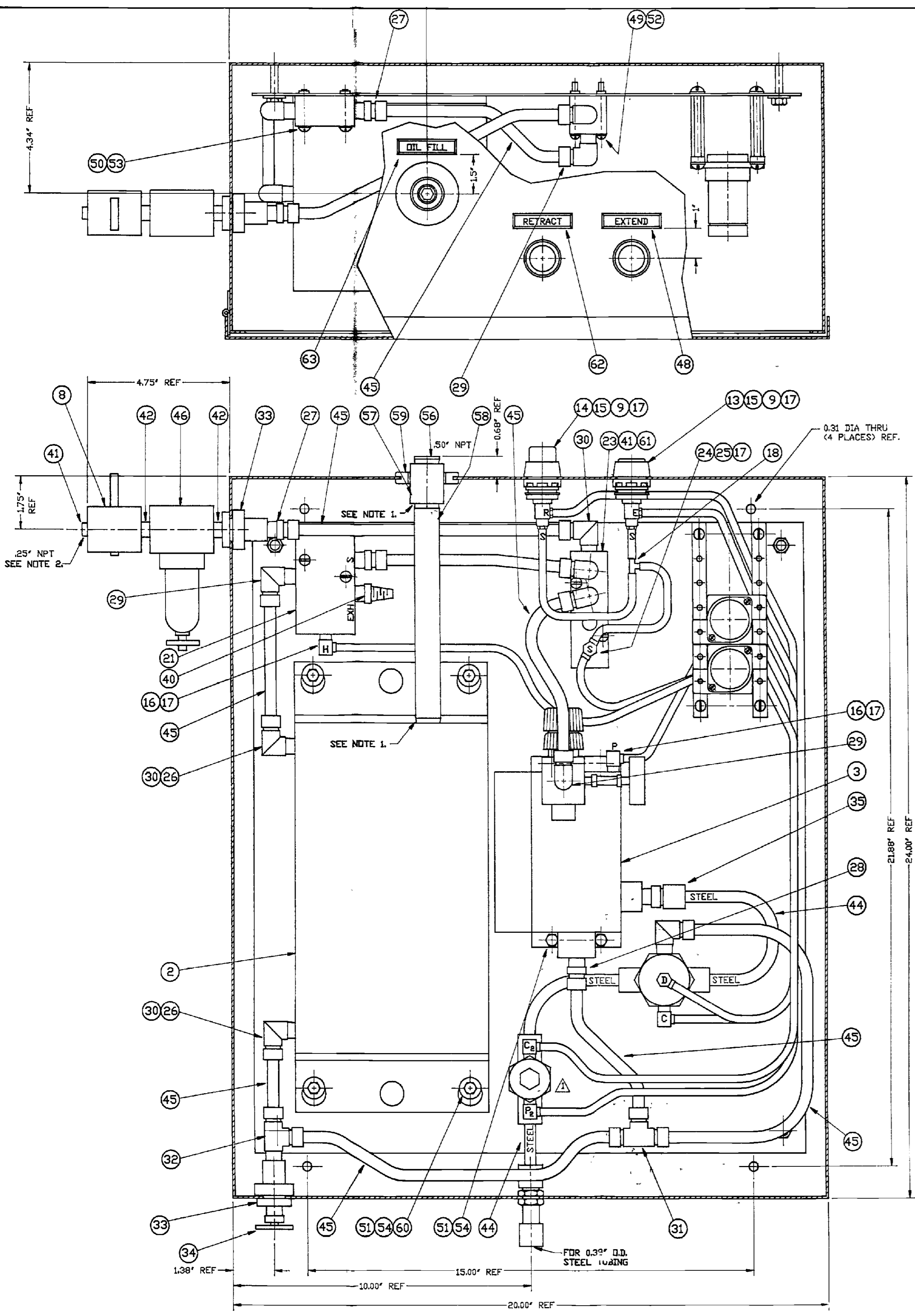

VIEW A-A
SCALE: 1=1

REF. DWG.- B - 41097010 AIR/OIL SCHEMATIC
SEE SEPARATE PARTS LIST - 696554

- NOTES:
1. USE LOCKTITE
2. FOR SHIPPING ONLY.
3. ALL PIPE THREAD FITTINGS USE TEFLON PASTE UNLESS OTHERWISE NOTED (DO NOT USE TEFLON TAPE)

| | | | | |
|--|--------------------------------------|------|----------------|----------|
| REV | DESCRIPTION | BY | DATE | APPD. |
| 2 | ADDED ITEM 64 & 65 | JR | 3/11/92 | BHP |
| 1 | REVISED LABELING OF AIR PILOT SWITCH | JR | 5/6/92 | BHP |
| NETZSCH INC. EXTON, PA. 19341-1393 | | | | |
| TITLE 470MM & 630MM LP AIR/OIL POWER PACK | | | | |
| DRAWN | JR | DATE | 4/2/92 | CHKD |
| SCALE | .5=1 | APPD | BHP | DATE |
| SHEET NUMBER | 1 of 1 | SIZE | DRAWING NUMBER | SHTY REV |
| ORDER/PROJECT NUMBER | D41097112 | | | |

02349HHBIX

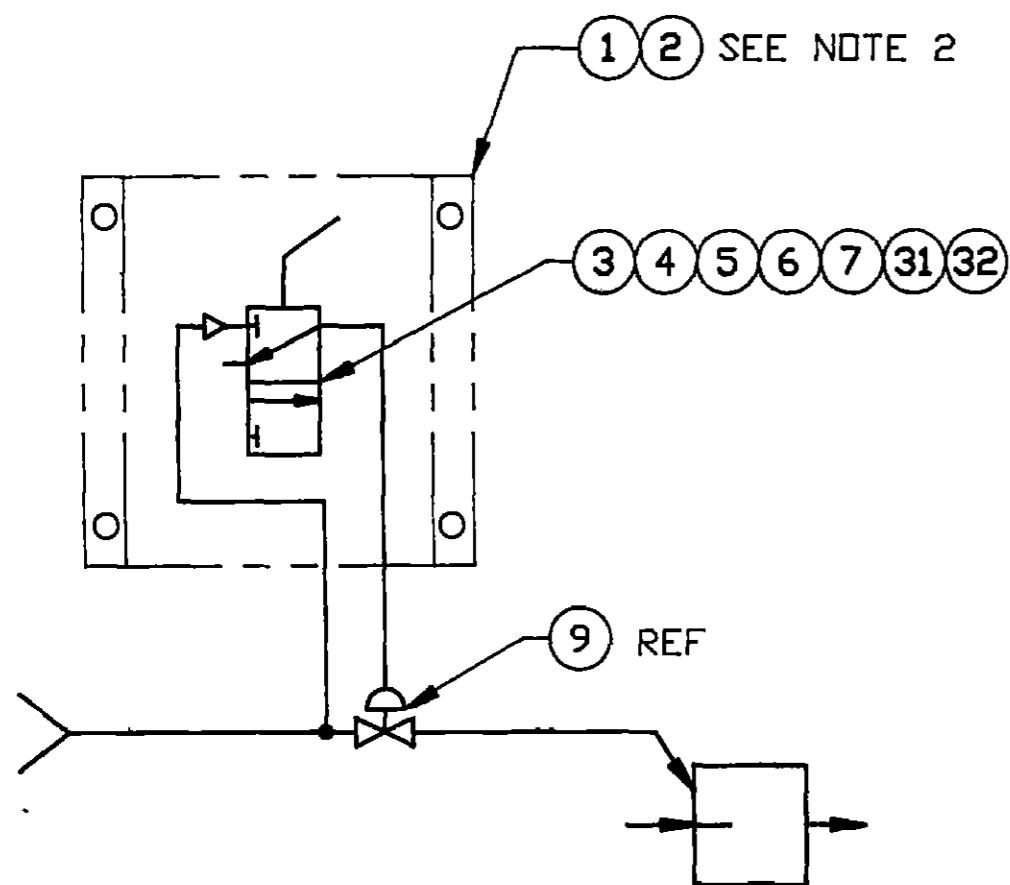
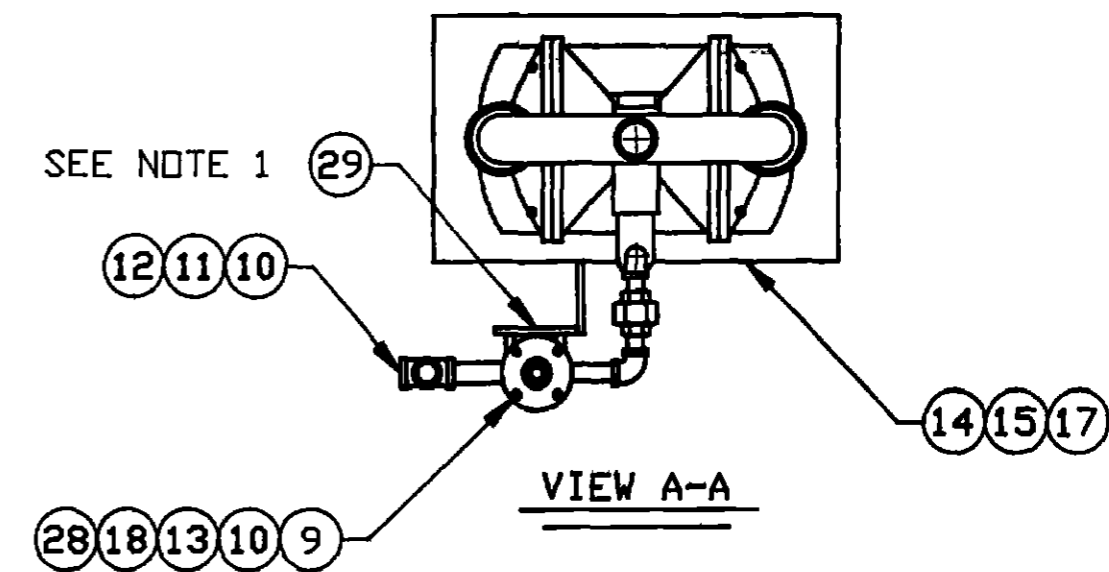
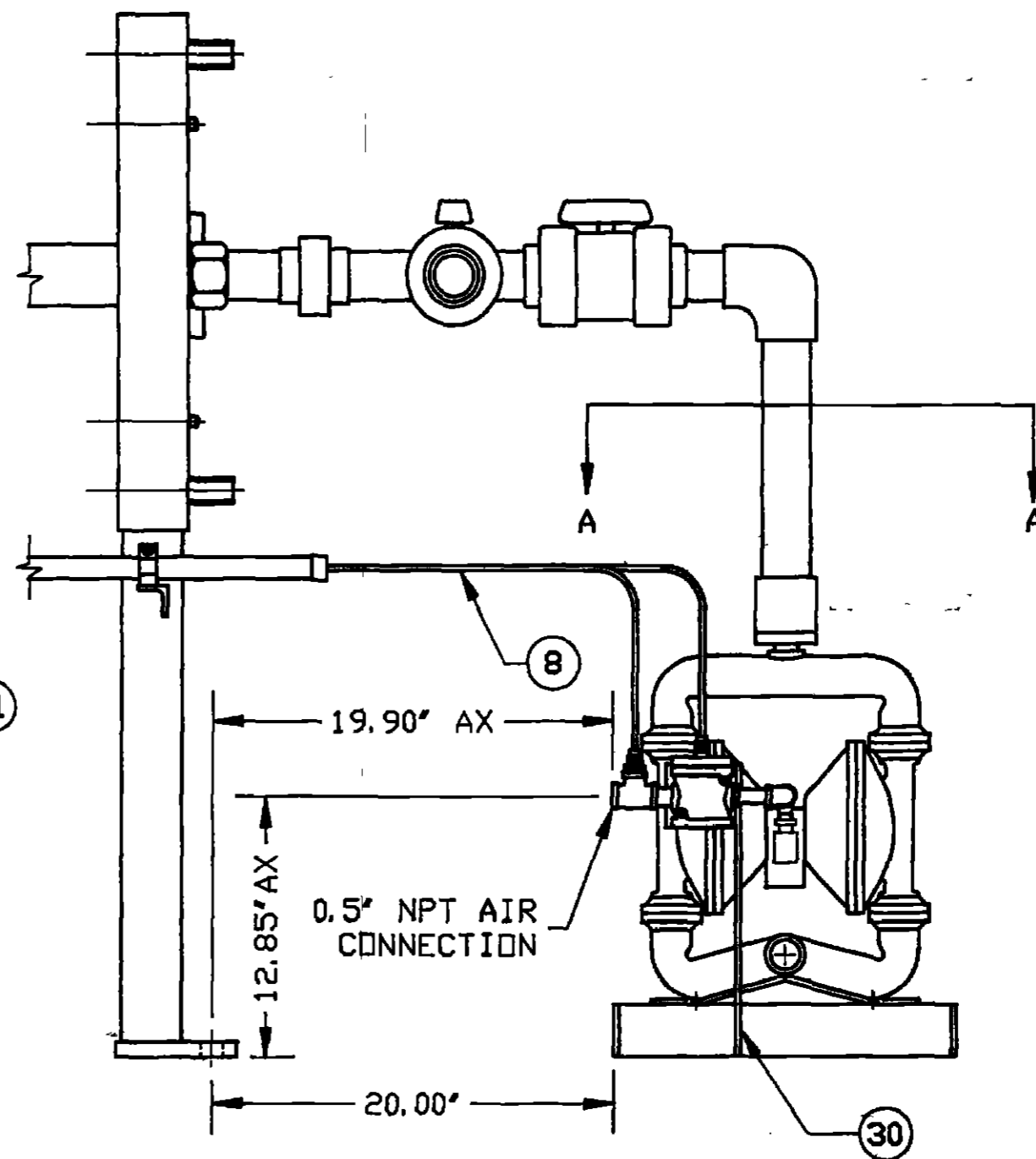
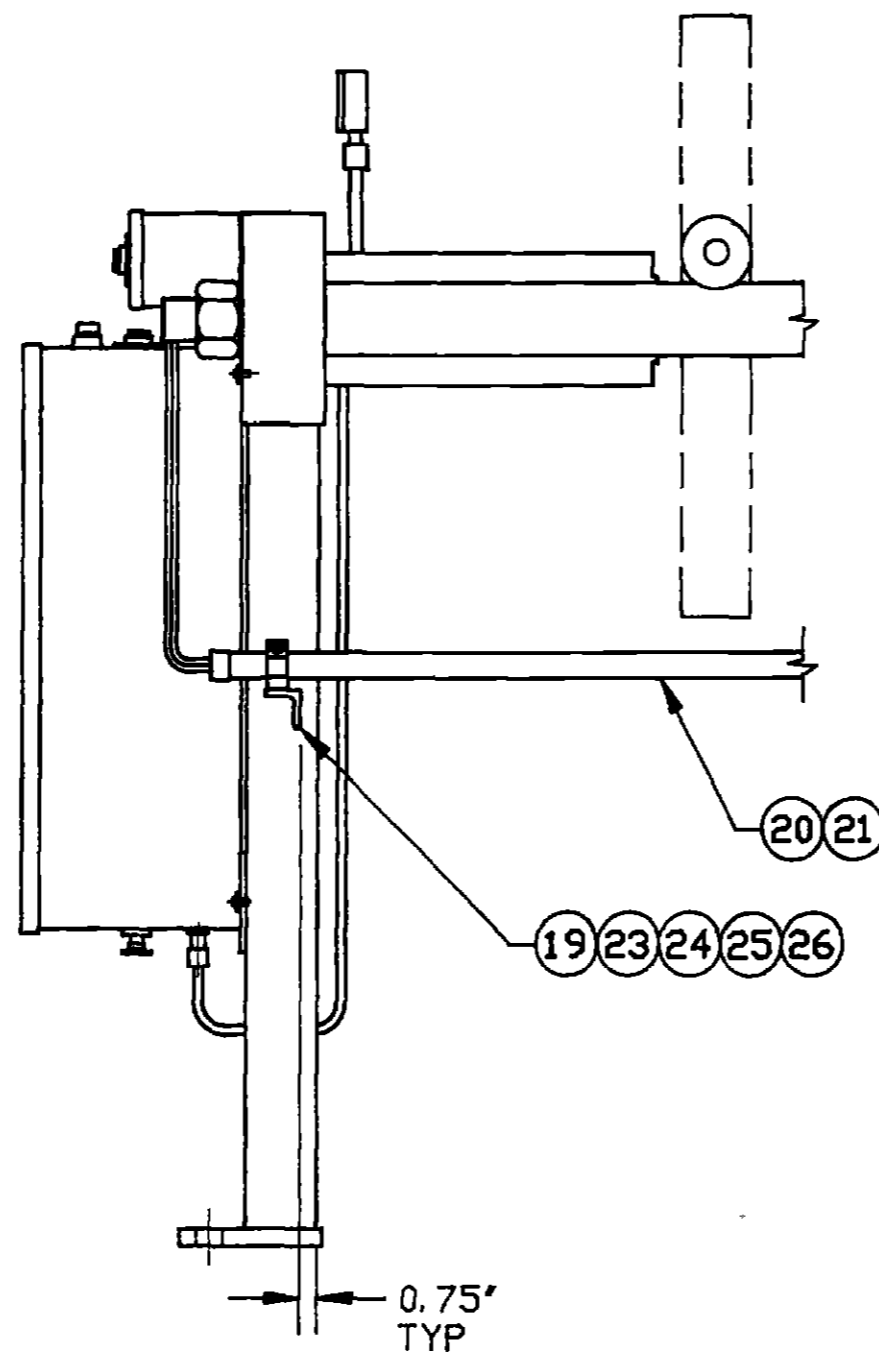
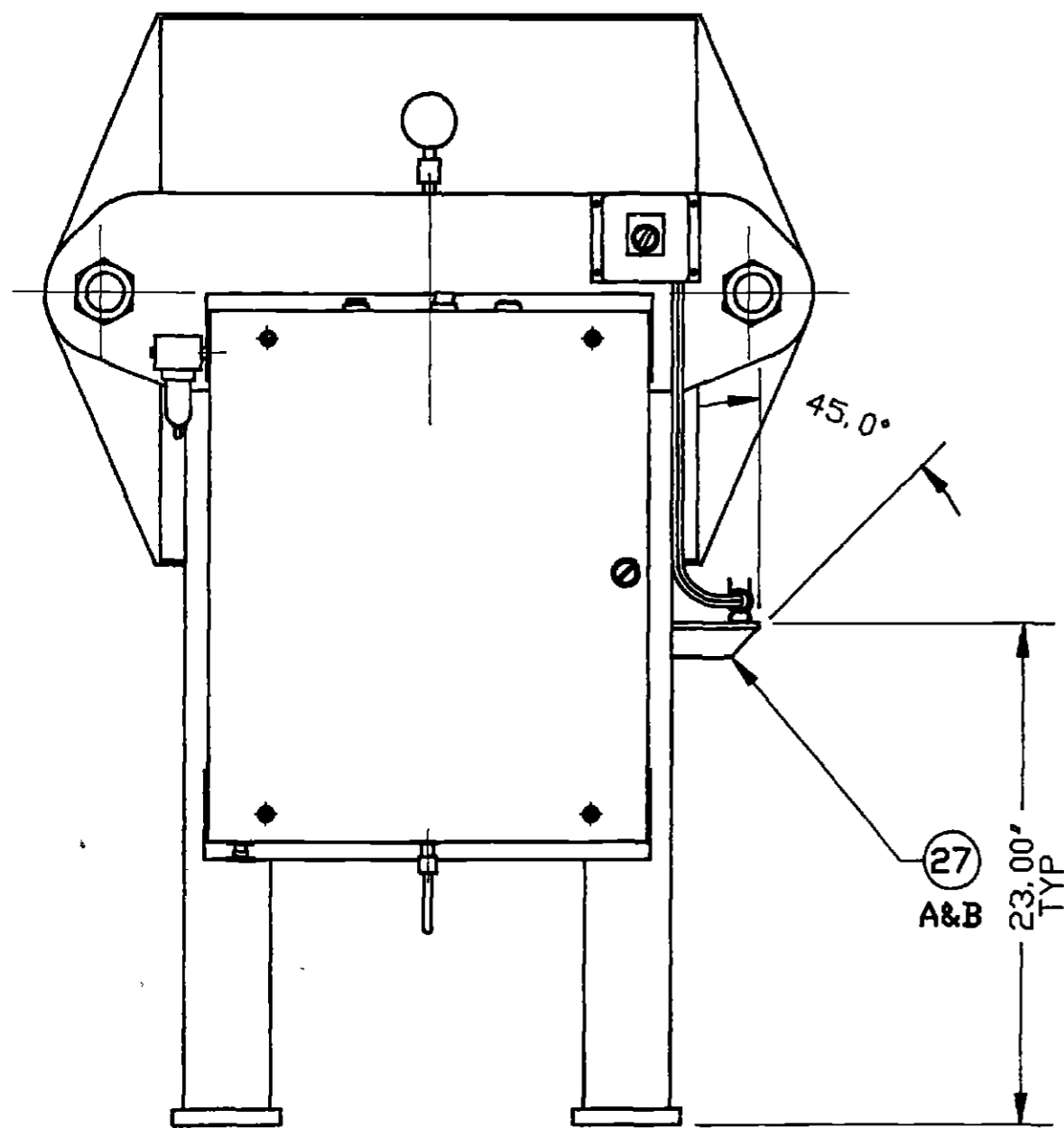

FEED PUMP
DETAIL ITEM# 31

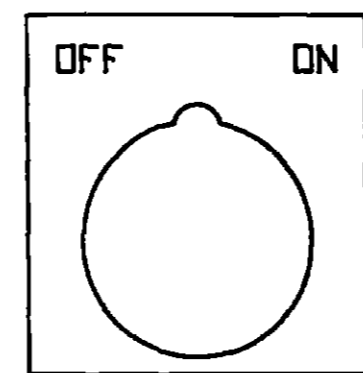

DETAIL ITEM# 32

- NOTES:
 1. DRILL (2) .31 ϕ HOLES AT ASSY
 2. DRILL 1.25 ϕ HOLE AT ASSY FOR ITEM 2

P/N 698542

| REV. | DESCRIPTION | BY | DATE | APP'D. |
|---|-------------|--------------------------|----------------|--------------|
| | | | | |
| NETZSCH INCORPORATED EXTON, PA. 19341-1393 | | | | |
| TITLE PUMP CONTROL SYSTEM AIR OPERATED 630 I LP | | | | |
| DRAWN TH DATE 04/24/95 | | CHKD | DATE | |
| SCALE .125=1 | | APP'D. <i>Bill Davis</i> | | DATE 4/28/95 |
| SHEET NUMBER of | | SIZE | DRAWING NUMBER | SHT REV |
| ORDER/PROJECT NUMBER | | C 41170510 | | |

NETZSCH
Filtration Systems

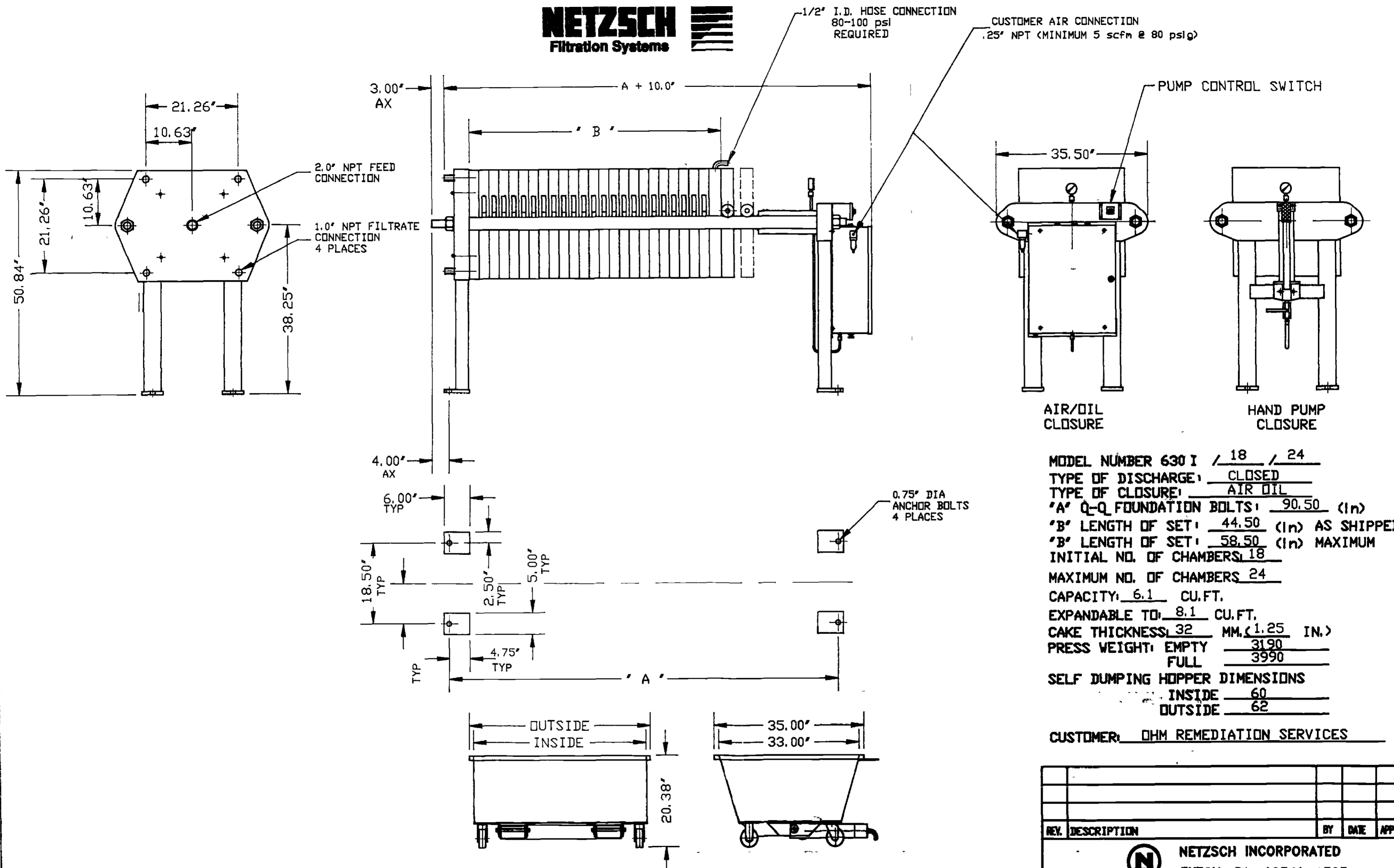

MODEL NUMBER 630 I / 18 / 24
 TYPE OF DISCHARGE: CLOSED
 TYPE OF CLOSURE: AIR OIL
 'A' Q-Q FOUNDATION BOLTS: 90.50 (In)
 'B' LENGTH OF SET: 44.50 (In) AS SHIPPED
 'B' LENGTH OF SET: 58.50 (In) MAXIMUM
 INITIAL NO. OF CHAMBERS: 18
 MAXIMUM NO. OF CHAMBERS: 24
 CAPACITY: 6.1 CU.FT.
 EXPANDABLE TO: 8.1 CU.FT.
 CAKE THICKNESS: 32 MM. (1.25 IN.)
 PRESS WEIGHT: EMPTY 3190
 FULL 3990
 SELF DUMPING HOPPER DIMENSIONS
 INSIDE 60
 OUTSIDE 62

CUSTOMER: DHM REMEDIATION SERVICES

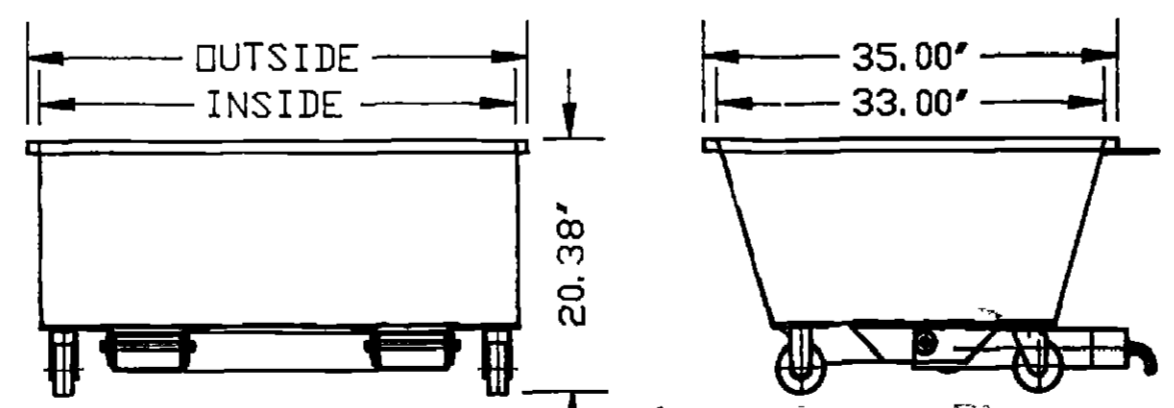

OPTIONAL SELF-UNLOADING DUMPSTER

NOTES:

1. MAXIMUM PRODUCT OPERATING PRESSURE 100 psig
2. DO NOT WELD TO PRESS STRUCTURE WITHOUT PRIOR APPROVAL OF NETZSCH INCORPORATED
3. FILTRATE CONNECTIONS TO BE PIPED FOR GRAVITY DRAIN

| | | | | |
|--|---------------------------|----------------|-------------|---------|
| REV. | DESCRIPTION | BY | DATE | APP'D. |
| NETZSCH INCORPORATED EXTON, PA. 19341-1393 | | | | |
| TITLE 630mm LP FILTER PRESS CLOSED FILTRATE | | | | |
| DRAWN TH | DATE 04/19/95 | CHKD | DATE | |
| SCALE .0625=1 | APP'D. <i>[Signature]</i> | | DATE 5-1-95 | |
| SHEET NUMBER 1 of 1 | SIZE | DRAWING NUMBER | | SHT REV |
| ORDER/PROJECT NUMBER | C 41170310 | | | |
| 0401088095 | | | | |

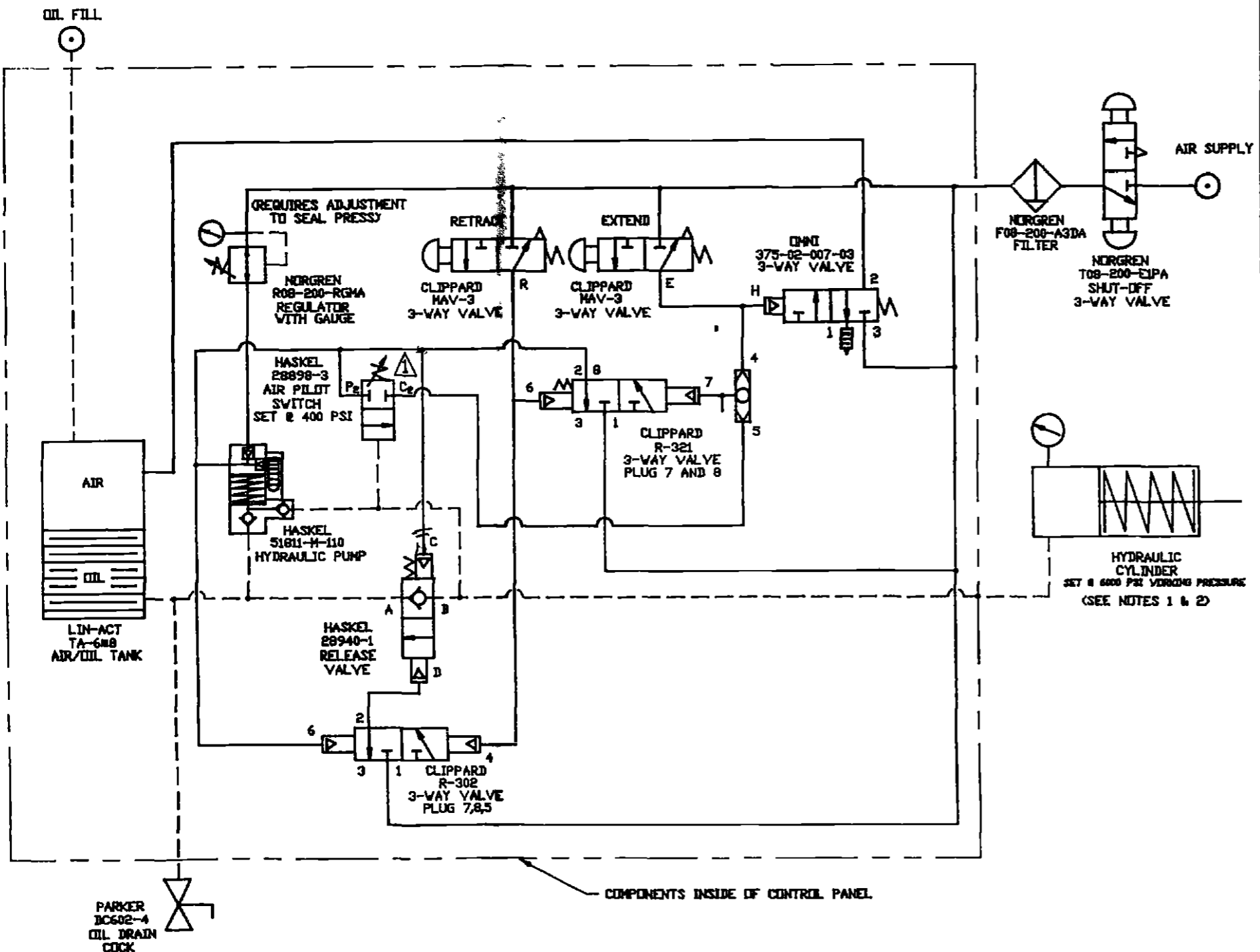

NOTES:
 1. TO AVOID DAMAGING CYLINDER, DO NOT EXTEND & PRESSURIZE TO END OF STROKE.
 2. ADJUST AIR REGULATOR TO ACHIEVE 6000 PSI @ CYLINDER WHEN FILTER PRESS IS CLOSED.

--- OIL LINES
 — AIR LINES

REF. DWG. D-41097110 AIR/OIL POWER PACK ASSY.

COMPONENTS INSIDE OF CONTROL PANEL

| MACHINING TOLERANCES UNLESS OTHERWISE SPECIFIED | |
|--|--------|
| .X | ± .030 |
| .XX | ± .015 |
| .XXX | ± .005 |
| ANGLES ± 1° | |
| FRACTION ± 1/16" | |

| REV. | DESCRIPTION | BY | DATE | APP'D. |
|------|---------------------------------------|----|----------|--------------------|
| 2 | CHANGED 7000 psi TO 6000 psi | TH | 07/19/94 | <i>[Signature]</i> |
| 1 | REVISED LABELING OF AIR PILDOT SWITCH | JR | 5/6/92 | BHP |

NETZSCH INC.
 EXTON, PA. 19341-1393

TITLE **470MM & 630MM LP AIR/OIL SCHEMATIC**

| | | |
|----------------------|-------------------|----------------|
| DRAWN JR DATE 4/1/92 | CHKD | DATE |
| PLOT @ .5=1 | APP'D BHP | DATE 4/3/92 |
| SHEET NUMBER 1 of 1 | SIZE | DRAWING NUMBER |
| ORDER/PROJECT NUMBER | B 41097012 | |

NOTE:
1. PVC PIPE TO BE CUT TO FIT AT ASSY.

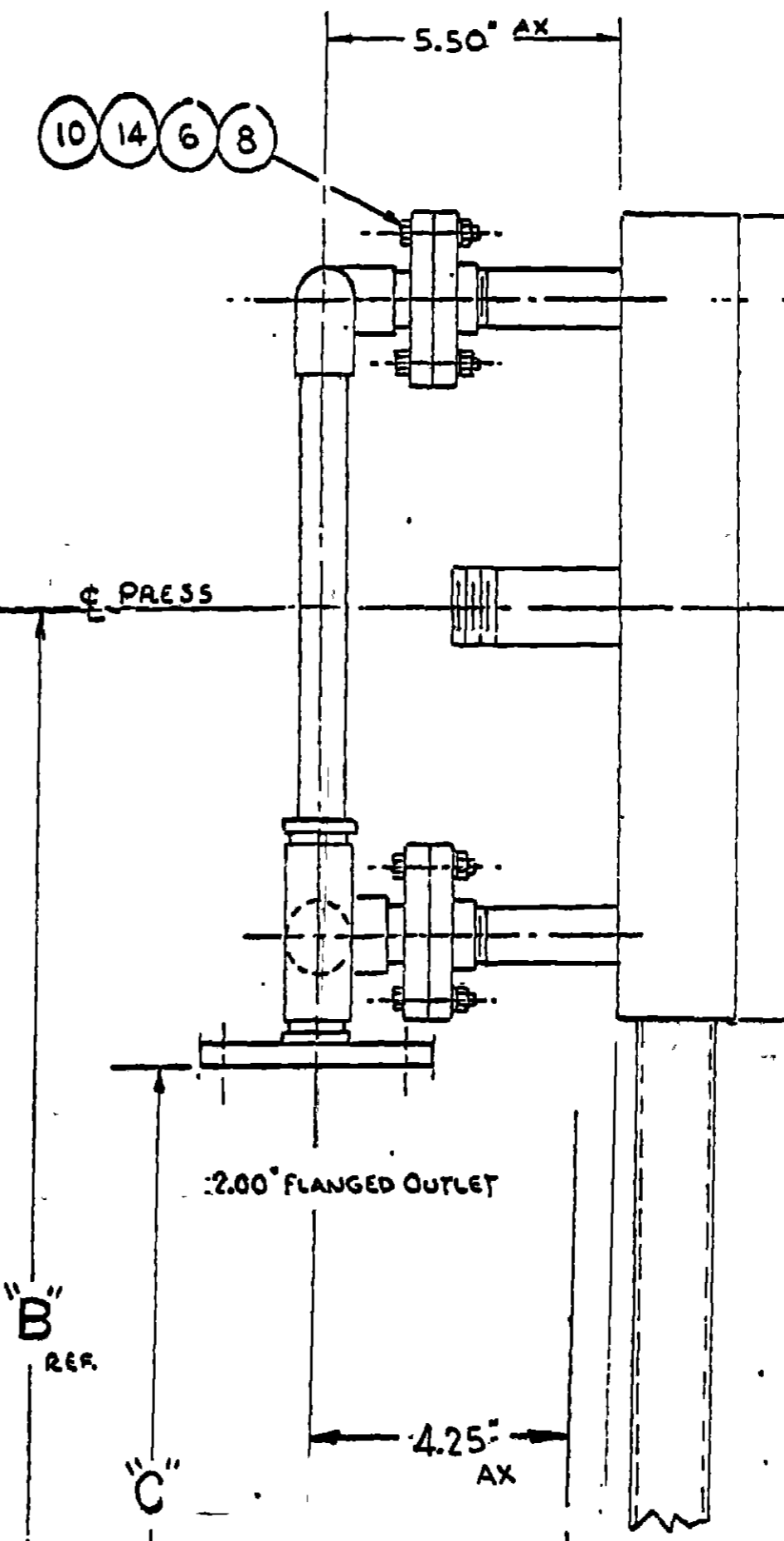
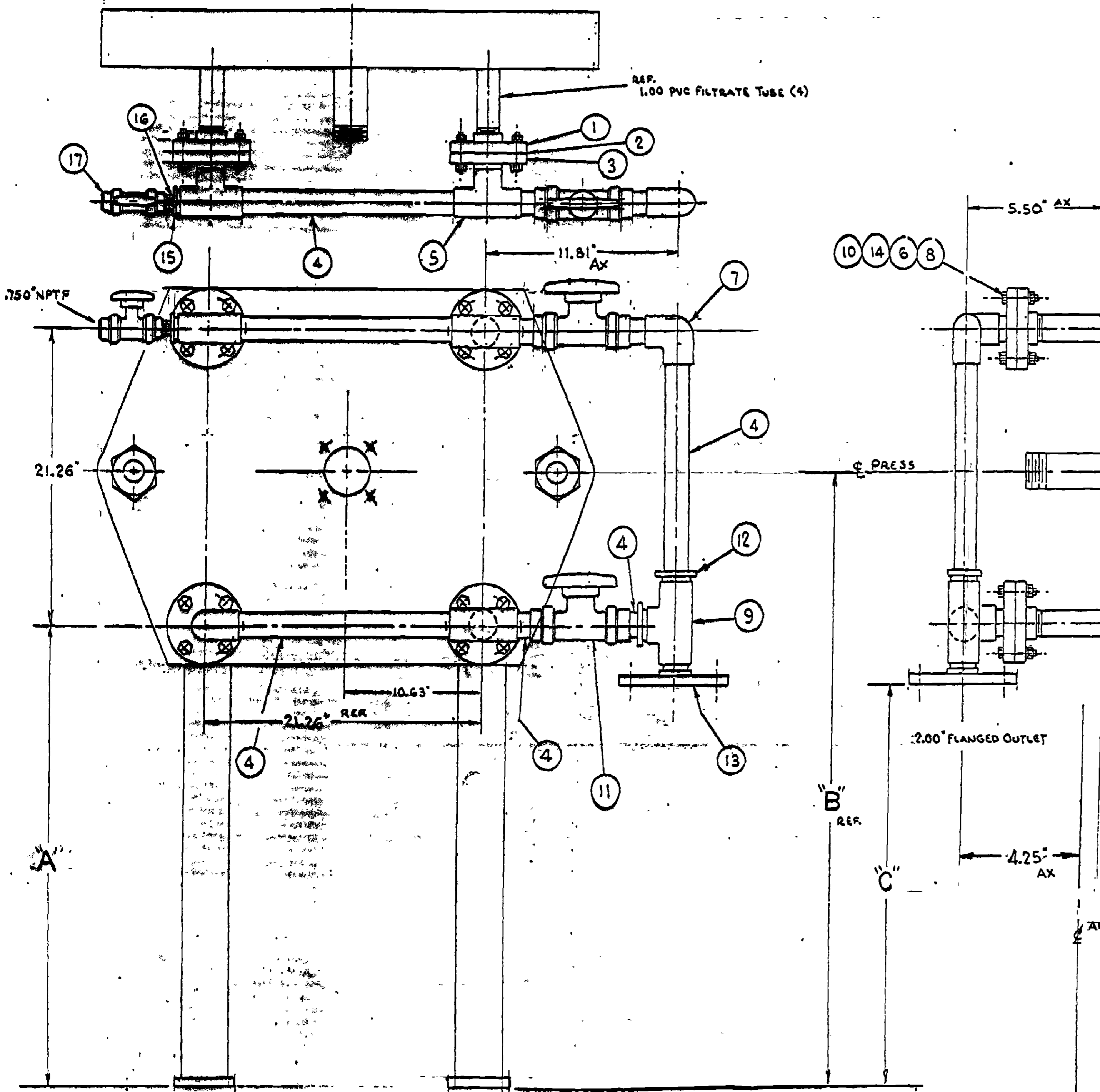

| PART NO | A | B | C |
|---------|-------|-------|-------|
| 697001 | 22.62 | 38.25 | 24.75 |
| 698281 | 59.87 | 70.50 | 57.00 |

A

B
RER

C

ANCHOR BOLT

| REV. | BY | DATE | APPD. |
|------|----|----------|-------------|
| 2 | JC | 2/10/95 | [Signature] |
| 1 | JC | 10/25/92 | [Signature] |

NETZSCH INC.
Exton, PA 19341-1393

TITLE
FILTRATE HEADER ASSY. 630LP w/AIR BLOW

DRAWN GH DATE 10-15-92 QWRD DATE

SCALE NONE APPD. [Signature] DATE 10/16/92

SHEET NUMBER 1 of 1 DRAWING NUMBER

PROJECT NUMBER **C-41114512** DWT REL

INGERSOLL RAND - AIR COMPRESSOR

Site: MCB Camp Lejeune, NC - OU2
Groundwater Treatment Plant
Delivery Order No. 0015

Date service rep on site: February 6, 1996

Name of representative: Mr. Gary Michael
(770) 936-6200

Questions & Comments:

Question: Should the air compressor be run continuously?

Comments: Normal usage of compressed air in the water treatment plant is approximately 12 cfm. The air compressor is designed for 100 cfm total from the two air compressors. The air compressor can be run in intermittent operations instead of continuous. If the air compressor cycles more than 6 times per hour, then the compressor should be run in the continuously mode.

Question: How do you make the compressor run continuously?

Comments: This can be done by turning the set screw on the auxiliary brass valve (located behind the pressure gauge directly underneath the air compressor crankcase). Turning clockwise all the way down will make the compressor run intermittently, and "on" and "off" will be regulated by tank pressure. Turning the set screw counterclockwise all the way up allows the compressor to run continuously. If the air tank is full, the air compressor will stop, but the motor will keep running under the continuous mode.

Question: Will the two air compressors come on together?

Comments: The two air compressors will cycle alternately by a cycle relay. But if the air pressure is really low in the air tank, both compressors will come on together.

Question: Do the air compressor need a oil separator?

Comments: There is a coalescent filter at the air dryer outlet to capture the oil. The filter should be drained once a day or once a shift.

Question: What are the pressures set at for the compressor to turn on and off?

Comments: The air compressors are set to turn off automatically at 125 psi, and turn on automatically at 80 psi. The "on" pressure can be adjusted by turning the green colored spring inside the regulator box (one for each compressor) up or down. Turning the screw clockwise and lower the spring downward raises the "on" pressure, and counterclockwise and up to decrease the "on" pressure.

Question: What would the compressed air exit temperature be at the compressor discharge?

Comments: The compressed air temperature at the compressor outlet prior to the aftercooler is around 400 deg F. High temperature shut off is set at 500 deg F. If high

Ingersoll Rand - Air Compressor

Page 2 of 2

temperature trips the compressor, it needs to be reset with the 'reset' button located underneath the compressor mounted on the frame. Then press the reset button on the control panel to reset the alarm light.

Question: What is the exit air temperature after the air dryer?

Comments: The exit air temperature after the aftercooler is about 100 deg F. and about 95 deg F. after the air dryer. The air dryer cools the air to drop out the moisture and reheats it at the exit.

Question: What are the ratings for the compressed air line or 'green' line made by Chemtrol?

Comments: The Chemtrol air lines are rated for 185 psi at 110 deg F. but drops significantly to 100 psi at 140 deg F.

Question: What is the pressure relief valve on the air tank set at?

Comments: The pressure relief valve (located behind the control panel) on the air tank is set to open at 135 psi and has demonstrated to do so.

Question: What are the lubrication schedules?

Comments: The motor bearings (two on each motor) should be greased once every three months. The motor oil in the air compressor crankcase should be checked daily with the dip stick. The oil should be changed after the first 500 hours of operation, and every 1,000 hours afterwards. The oil must be re-filled when the low oil level light is illuminated in the panel.

Question: What are the pressures for the intercooler and the distance piece?

Comments: The normal pressure for the intercooler is 30 psi, and a max of 60 psi. The normal pressure for the distance piece is about 15 psi.

Question: Does the air dryer need to be warmed up prior to start up?

Comments: The air dryer needs to be warmed up for 24 hours, by turning the power on, if the dryer has been sitting on a shut down mode for a long time and the unit is cold. Warming the dryer will help to separate the Freon from the motor oil in the crankcase prior to starting the unit up.

Question: What should you do when the high evaporator temperature alarm comes on in the dryer?

Comments: When the high evaporator temperature comes on in the dryer, the coil at the front end of the dryer needs to be cleaned.

Question: Do you need to drain the water from the air tank?

Comment: The air tank is equipped with an automatic solenoid drain valve that will open automatically. This solenoid valve should be plugged into an outlet. The hand valve upstream of the solenoid should be left on.

INGERSOLL-RAND®

AIR COMPRESSORS

DXR_{SERIES}

**DXR SERIES
REFRIGERATED AIR DRYERS**

| | | |
|--------|--------|---------|
| DXR75 | DXR230 | DXR750 |
| DXR100 | DXR300 | DXR1000 |
| DXR140 | DXR425 | |
| DXR180 | DXR550 | |

This dryer was purchased from (Distributor name,
Address and phone no.)

Name _____

Address _____

Phone No. _____

Ingersoll-Rand Company reserves the right to make changes or add improvements without notice and without incurring any obligation to make such changes or add such improvement to products sold previously.

Model _____

Qty. on order _____

Customer Order No. _____

Ingersoll-Rand Order No. _____

For ready reference:

Record the serial number and model number of your dryer here.

Serial No. _____

Model No. _____

Bulletin IR553 Revision C 12/94
Ingersoll-Rand Company 1994

OPERATOR'S INSTRUCTION MANUAL

Before installation or starting the dryer for the first time, study this manual carefully to obtain a clear knowledge of the dryer and of the duties to be performed while operating and maintaining the dryer.

RETAIN THIS MANUAL WITH DRYER.

This technical manual contains IMPORTANT SAFETY DATA and should be kept with the dryer at all times.

Table of Contents

| | |
|---|-----------|
| INTRODUCTION | 1 |
| SAFETY | 1 |
| Safety Instructions | 1 |
| Safety Labels | 1 |
| Data Plate | 1 |
| RECEIVING AND INSPECTION | 1 |
| INSTALLATION | 2 |
| Ambient Air Temperature | 2 |
| Location and Clearance | 2 |
| System Arrangement | 2 |
| Piping and Connections | 2 |
| Drains | 2 |
| Electrical Connections | 3 |
| Cooling Water | 3 |
| Air-cooled Models | 3 |
| HOW IT WORKS | 3 |
| Airflow | 3 |
| Refrigeration System | 4 |
| INSTRUMENTATION | 4 |
| Power ON Signal | 4 |
| High Evaporator Temperature Light | 4 |
| SYSTEM OPERATION MONITOR | 5 |
| Indicating lights | 5 |
| Temperature SCAN/SEEK button | 6 |
| Critical Air and Refrigerant Temperatures | 7 |
| Intermediate Air Temperature | 7 |
| Remote Alarm Contacts | 8 |
| AUTOMATIC DRAIN VALVE (ADV) | 8 |
| Equipment rated 75 scfm through 300 scfm | 8 |
| All Other Models | 8 |
| SIZING VERIFICATION | 8 |
| START-UP | 9 |
| SHUTDOWN | 10 |
| MAINTENANCE | 10 |
| General | 10 |
| Daily Maintenance | 11 |
| Monthly Maintenance | 11 |
| SERVICE DUE Indicator | 11 |
| Ambient Air Filter | 11 |
| Returns to Manufacturer | 11 |
| Automatic Drain Valve Disassembly and Servicing | 11 |
| FIELD SERVICE GUIDE | 12 |
| SPECIFICATIONS | 17 |
| REPLACEMENT PARTS | 18 |
| ELECTRICAL SCHEMATICS | 20 |

INTRODUCTION

DXR Series refrigerated air dryers use mechanical refrigeration to dry compressed air to pressure dew points as low as NFPA Class H (33°F-39°F). They deliver the required dew point at specified inlet air temperature, pressure and airflow. Any change in these operating conditions may affect performance. See Table 11 for rated capacity and other dryer specifications.

To ensure continuing good performance and safe operation of the dryer, everyone who installs, uses or maintains it must read and carefully follow the instructions in this manual.

SAFETY

DXR Series dryers are designed and built with safety as a prime consideration; industry-accepted safety factors have been used in the design. Each dryer is checked at the factory for safety and operation. All necessary adjustments are made before shipment.

Follow the maintenance schedules outlined in this manual for good performance and safe operation. Maintenance should be done only by qualified personnel with proper tools.

Carefully read the following safety rules before proceeding with installation, operation or maintenance. The rules are essential to ensure safe dryer operation. Failure to follow these rules may void the warranty or result in dryer damage or personal injury.

1. Do not install or try to repair a dryer that has been damaged in shipment. See Receiving and Inspection for instructions.
2. Compressed air and electricity have the potential to cause personal injury or equipment damage. Before doing any work on the dryer, be sure the electrical supply has been locked and tagged and the internal pressure of the dryer has been vented to the atmosphere.
3. Do not operate the dryer at pressures or temperatures above the maximum conditions shown on the data plate.
4. Always supply electrical power that complies with the voltage shown on the data plate.

5. Do not readjust the dryer without factory authorization.
6. Work on the refrigeration system must be done only by a competent refrigeration mechanic.
7. Use only manufacturer's genuine replacement parts. The manufacturer bears no responsibility for hazards caused by the use of unauthorized parts.

Safety Instructions

Safety instructions in this manual are boldfaced for emphasis. The signal words **DANGER**, **WARNING** and **CAUTION** are used to indicate hazard seriousness levels as follows:

DANGER—Immediate hazard which **WILL** result in severe injury or death.

WARNING—Hazard or unsafe practice which **COULD** result in severe injury or death.

CAUTION—Hazard or unsafe practice which **COULD** result in minor injury or in product or property damage.

Safety Labels

Dryer labels providing important safety information are included in this manual near corresponding text. If any of the labels is missing or damaged, contact your local distributor, request the label by its part number and apply it to the dryer.

Data Plate

The dryer data plate contains critical safety and identification information. If the data plate is missing or damaged, contact your local distributor and request a replacement.

RECEIVING AND INSPECTION

Inspect the dryer closely when it is received. Record any indication of damage on the delivery receipt, especially if the dryer will not be immediately uncrated. Obtain the delivery person's signed agreement to recorded damages to facilitate future insurance claims.

Since the dryer is shipped F.O.B. New Castle, Delaware, the manufacturer's responsibility for the shipment ceases when the carrier signs the bill of lading.

If goods are received short or in damaged condition, notify the carrier and insist on a notation of the loss or damage across the face of the freight bill. Otherwise no claim can be enforced against the carrier.

If concealed loss or damage is discovered, notify your carrier at once and request an inspection. This is absolutely necessary. Unless you do this the carrier will not consider any claim for loss or damage. The carrier will make an inspection and may grant a concealed damage notation. If you give the carrier a clear receipt for goods that have been damaged or lost in transit, you do so at your own risk and expense.

The manufacturer is willing to assist you in collecting claims for loss or damage. Willingness does not make the manufacturer responsible for collecting claims or replacing material. Claim filing and processing is your responsibility.

INSTALLATION

Ambient Air Temperature

Locate the dryer indoors where the ambient air temperature will be between 40°F and 100°F. Intermittent operation at ambient temperatures up to 120°F will not damage the dryer but may result in a higher dew point or dryer shutdown due to high refrigerant discharge pressure (see Field Service Guide). Call your local distributor if prolonged operation at ambient temperatures above 100°F or below 40°F is unavoidable.

Do not operate air-cooled dryers at ambient air temperatures below 40°F. Such operation may result in low suction pressure, causing freeze-up.

Location and Clearance

Mount the dryer on a level base and bolt down if base vibrates. If the dryer is air cooled, install it in a clean, well ventilated area to reduce fouling of the condenser coils with dirt and dust. Allow 24 inches clearance on the sides and front of the dryer for cooling airflow on air-cooled dryers and for service access on both air-cooled and water-cooled dryers.

System Arrangement

Liquid water adversely affects dryer performance. To prevent "slugging" the dryer with liquid water, locate the dryer downstream of an aftercooler and a mechanical separator. Install drain valves to discharge condensate that collects in these areas.

If the airflow is relatively constant and will not cause short term overloading of the dryer, it is recommended that the dryer be located downstream of the receiver tank. If the nature of the application is such that the air demand regularly exceeds the dryer flow rating, it is recommended that the dryer be located upstream of the receiver.

For safety and convenience, install inlet and outlet shutoff valves and depressurization valves at the locations indicated. These valves allow the dryer to be isolated and depressurized for servicing. Bypass piping may be installed around the dryer for uninterrupted airflow when the dryer is serviced. If the compressed air operation cannot tolerate undried air for short periods, install a second dryer in the bypass line.

Compressed air systems commonly require filters to remove compressor oils, particulates, condensed liquids and other contaminants. When an oil-removal filter is used, install the filter downstream of the DXR Series dryer. At this location, the life of the replaceable filter element is prolonged since some of the entrained oil is removed by the dryer and drained through the separator.

Piping and Connections

Piping must be furnished by the user unless otherwise specified. Connections and fittings must be rated for the maximum operating pressure given on the dryer data plate and must be in accordance with applicable codes. Support all piping; do not allow the weight of any piping to stress the dryer or filters. Proper sizing of piping should be determined using good engineering practice. See Table 10 for dryer inlet and outlet connections.

Drains

Condensate must be drained from the dryer to prevent its reentrainment. The dryers are equipped with an automatic drain valve. A condensate hose is coiled and secured inside the dryer cabinet for shipping. Uncoil the hose and run it to a waste disposal collection system that meets applicable regulations. Pipe or copper tubing 1/2-inch or larger is recommended for condensate discharge lines. Do not use 1/4-inch or 5/16-inch O.D. flexible tubing unless the

Discharge line is shorter than 10 feet. Install the discharge lines so that condensate can be seen as it drains.

Electrical Connections

Standard models are constructed according to NEMA Type 1 electrical standard. Field wiring must comply with local and national fire, safety and electrical codes. Installation must be in accordance with the National Electrical Code. Confirm that your line voltage is the same as the voltage listed on the data plate.

Dryers are wired so that the crankcase heaters (if supplied) and drain valves are energized when power is supplied, even if the power switch is turned off. See the electrical schematics for wiring details.

Cooling Water

Water-cooled condensers are optional. The suffix W on the model number indicates water-cooled. The user is responsible for piping the water to and from the condenser. A factory-installed water regulating valve in the condenser inlet connection is standard.

Required water flow rate depends on water temperature (refer to Table 1). The valve supplied with the dryer automatically adjusts the flow to compensate for variations in water temperature, water pressure and dryer air load.

Operating the dryer with inadequate condenser cooling water (temperatures above or pressures below those in Table 1) will cause a rise in dew point unless the dryer inlet airflow is reduced. The refrigerant discharge pressure control will shut down the refrigerant compressor if cooling water is inadequate.

If the cooling water is dirty, install a strainer ahead of the condenser inlet. Install shutoff valves so that the strainer can be drained and cleaned at regular intervals.

Air-cooled Models

Cooling air must be drawn from a clear, well ventilated area to reduce dust and dirt accumulation on the condenser coils. Air temperature should not exceed 100°F. Required air flow rates are shown in Table 2.

Table 1
COOLING WATER REQUIREMENTS

| DRYER MODEL | WATER CONN. (in NPT) | COOLING WATER REQUIRED ^a | | | | |
|-------------|----------------------|-------------------------------------|------|------|------|------|
| | | 60°F | 70°F | 80°F | 85°F | 90°F |
| | | GPM | GPM | GPM | GPM | GPM |
| DXR180-W | 3/8 | .6 | .8 | 1.1 | 1.5 | 2 |
| DXR230-W | 3/8 | .4 | .7 | 1.1 | 1.5 | 2.1 |
| DXR300-W | 3/8 | .7 | 1 | 1.6 | 2.3 | 3.5 |
| DXR425-W | 3/8 | .6 | 1 | 2.1 | 2.7 | 4.2 |
| DXR550-W | 3/8 | 1.6 | 2 | 2.8 | 3.8 | 5.5 |
| DXR750-W | 1/2 | 1.5 | 2 | 3.7 | 5.4 | 10 |
| DXR1000-W | 1/2 | 2.5 | 3 | 4.5 | 5.7 | 9 |

^a Minimum water pressure is 25 psig for city water and 35 psig for tower water. Maximum water pressure is 150 psig.

Table 2
COOLING AIR REQUIREMENTS

| MODEL | COOLING AIR (cfm) |
|------------------------|-------------------|
| DXR75, DXR100, DXR140 | 475 |
| DXR180, DXR230, DXR300 | 1400 |
| DXR425 | 3000 |
| DXR550 | 2700 |
| DXR750 | 5200 |
| DXR1000 | 4800 |

HOW IT WORKS

Airflow (refer to Figure 1)

DXR Series dryers use refrigeration cooling to condense entrained moisture out of the airstream. Warm saturated air enters the air-to-air heat exchanger where it is cooled by outgoing cold air. The inlet air is further cooled in the refrigeration chiller. Cooling condenses entrained moisture. The condensate is removed by a centrifugal separator and an automatic drain valve.

The cold, dry air is reheated by incoming warm air as it passes back through the air-to-air heat exchanger. Using the outgoing air to pre-cool the inlet air condenses up to 65 percent of the moisture out of the inlet air before it reaches the chiller. Pre-cooling the inlet air reduces the heat load on the refrigerant compressor, permitting the use of a smaller refrigerant compressor.

Refrigeration System

The refrigeration system is designed and fabricated in accordance with recognized commercial/industrial practices. It consists of a compressor and the controls, safety interlocks and associated equipment necessary for safe performance.

In models DXR75 through DXR100 a constant pressure expansion valve modulates the refrigerant flow to eliminate freeze-ups and assure continuous, automatic dew point control. The constant pressure expansion valve adjusts the flow of liquid refrigerant to the chiller. The valve responds to pressure changes of refrigerant leaving the chiller to maintain the proper cooling rate under all load conditions.

Models rated for 140 scfm and larger utilize a thermostatic expansion valve (TEV) and a hot gas bypass valve (HGBV) to modulate the refrigerant flow. The TEV adjusts the flow of liquid refrigerant to the chiller. A temperature sensor downstream of the chiller opens and closes the TEV in response to the temperature of the refrigerant leaving the chiller to maintain the proper cooling rate under all load conditions. The HGBV delivers hot

refrigerant gas to the chiller in response to changes in refrigerant pressure. This prevents icing in the chiller and short cycling in the refrigerant compressor during extended periods of system operation at low load.

All refrigerant valves are adjusted at the factory; operation is fully automatic.

INSTRUMENTATION

Standard DXR Series dryers models DXR75 through DXR300 have two indicator lights: Power and High Evap Temperature.

Power Signal

All dryers are equipped with an ON-OFF switch on the front panel. A white light signals when power is on.

High Evaporator Temperature Light

The red High Evap Temperature light on the front panel warns the operator when the temperature inside the evaporator (chiller) is higher than normal. It is normal for this light to be on when the dryer is first turned on and remain on until the refrigeration system has reached normal operating temperatures (about 30 minutes). If the High Evap Temperature light turns on during normal dryer operation, turn the dryer off to avoid compressor damage. Have a refrigeration mechanic identify and correct the malfunction. If the dryer is under warranty, call your local distributor for authorization before servicing.

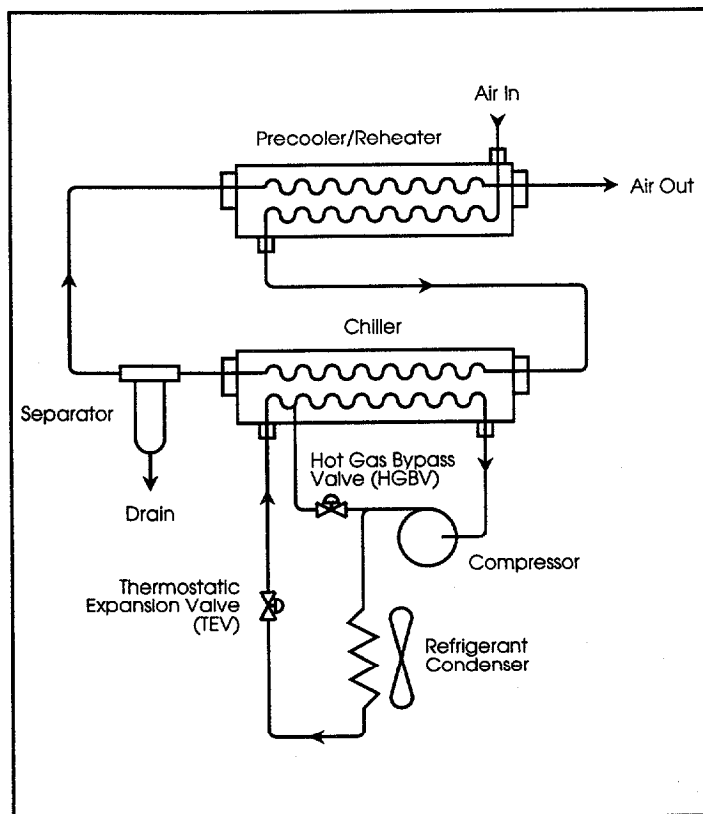

Figure 1.
Air and refrigerant flow schematic, models rated for 140 scfm and larger; for models rated 75 and 100 scfm, the TEV and HGBV are replaced by a single constant pressure valve (CPV).

SYSTEM OPERATION MONITOR

A System Operation Monitor is an option on dryers rated 75 scfm through 300 scfm (designated by the suffix T in the model number) and is standard on dryers rated 425 scfm and larger. The monitor measures and displays critical air and refrigerant temperatures, signals operating conditions which may affect dryer performance, and enables panel adjustment of the automatic drain valve. There is also a light to indicate the need for routine service.

The monitor consists of (refer to Figure 2):

- indicating lights
- alphanumeric display
- controls (push buttons) that provide access to critical air and refrigerant temperatures
- schematic with lights that correspond to the locations of the temperature sensors in the system
- drain valve controls
- temperature sensor probes

Indicating lights

The System Operation Monitor has four indicating lights: **NORMAL OPERATION**, **CHECK OPERATING CONDITIONS**, **SERVICE DUE** and **SYSTEM ALARM**. Table 3 provides instructions for using the indicating lights to monitor dryer operation.

NORMAL OPERATION—The green **NORMAL OPERATION** indicator will light when the temperature inside the evaporator (chiller) is normal.

CHECK OPERATING CONDITIONS—The red **CHECK OPERATING CONDITIONS** indicator will light when the temperature inside the evaporator is too high.

SERVICE DUE—The blue **SERVICE DUE** indicator will light under two conditions: as a reminder to perform routine maintenance after 4,500 hours of dryer service (approximately six months) and when a temperature sensor probe fails.

SYSTEM ALARM—The red **SYSTEM ALARM** indicator signals air system or dryer operating conditions that may affect dew point performance or cause damage to the dryer.

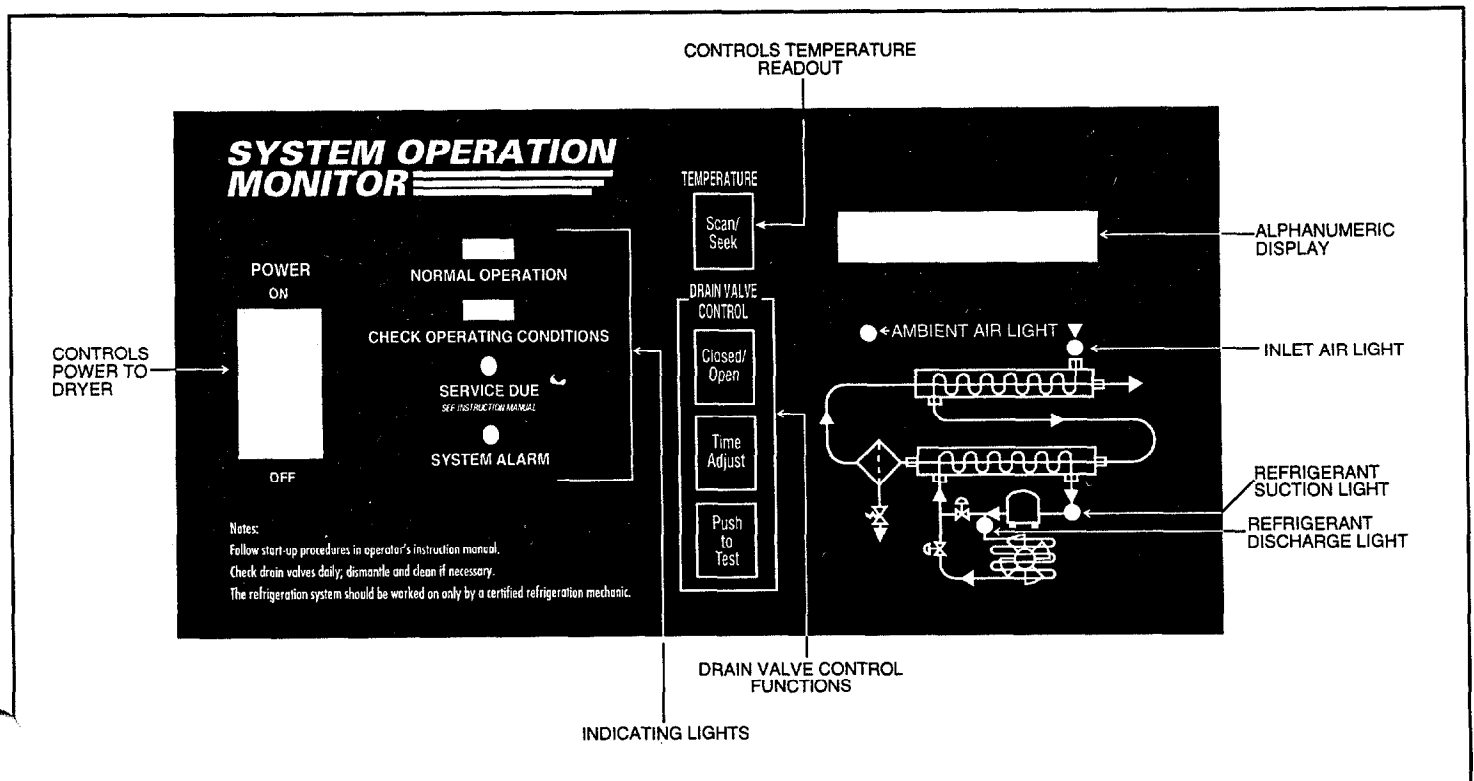

Figure 2.
System Operation Monitor

Temperature SCAN/SEEK push button

The SCAN/SEEK push button on the System Operation Monitor provides a readout on the alphanumeric display of the following temperatures:

- inlet air
- refrigerant suction
- refrigerant discharge
- ambient air

The display can be programmed to automatically scan each temperature for five seconds in sequence or to con-

tinuously display any selected reading. The corresponding light on the system schematic will illuminate when the temperature is displayed.

To scan the temperatures (normal mode): press and hold the SCAN/SEEK button for three seconds. Each temperature will then be displayed for five seconds in the following sequence: inlet air, refrigerant suction, refrigerant discharge and ambient air. To stop the scan mode push the TIME ADJUST button once.

To display any selected temperature (seek/test mode): press the SCAN/SEEK button once. The display will read the same temperature until the button is pressed again.

Table 3
SYSTEM OPERATION MONITOR INDICATING LIGHTS

| INDICATING LIGHT | INDICATES | ACTION REQUIRED | NOTES |
|-----------------------------------|--|---|---|
| NORMAL OPERATION | The temperature inside the evaporator (chiller) is normal. | This indicator should light within 30 minutes of start-up, after the refrigeration system has stabilized. It should remain on when the dryer is operating. | Indicator will go off if the CHECK OPERATING CONDITIONS indicator comes on or when a temperature sensor probe has failed. |
| CHECK OPERATING CONDITIONS | The temperature inside the evaporator (chiller) is too high. | It is normal for this light to be on when the dryer is first turned on and remain on until the dryer has reached normal operating temperatures (about 30 minutes). If the CHECK OPERATING CONDITIONS indicator turns on during normal operation, turn the dryer off to avoid compressor damage. Have a refrigeration mechanic identify and correct the malfunction. If the dryer is under warranty, call your local distributor for authorization before servicing | Indicator will remain illuminated until problem has been corrected. |
| SERVICE DUE | 1. 4,500 hours of dryer service (approximately six months) has passed; routine maintenance should be performed. | 1. See maintenance section in this manual for further instructions. | See maintenance section in this manual for instructions on resetting indicator. |
| | 2. A temperature sensor probe is sensing temperature outside of normal range or probe has failed. The probe may sense temperatures outside of normal range for up to two minutes after startup or in extreme temperature conditions. (The alphanumeric display will read T1, T2, T3, T4 or T5 MALFUNCTION. T1 = inlet air, T2 = refrigerant suction, T3 = refrigerant discharge, T4 = ambient air, T5 = evaporator.) | 2. Check sensor probe. Replace if necessary. | Indicator will go off when the dryer is turned off. This will not affect the 4,500 hour routine maintenance indicator. |
| SYSTEM ALARM | 1. Inlet air temperature is too high. | Determine which temperature(s) is out of range. See Table 3 and the Field Service Guide in this manual for possible causes/remedies | Indicator will not stop flashing until the problem has been corrected. |
| | 2. Refrigerant suction temperature is too low. | | |
| | 3. Ambient air temperature is too low. | | |
| | 4. Ambient air temperature is too high. | | |

When in seek mode, it will not monitor for abnormal conditions.

Critical Air and Refrigerant Temperatures

Table 5 provides the normal range for each displayed temperature when the dryers are operated in accordance with specified conditions. If a temperature reaches the **warning** set point indicated in the table, the corresponding light on the system schematic will flash during the 5-second display. If the temperature reaches the **alarm** set point indicated in the table, the System Alarm indicator will flash. Refer to the Field Service Guide in this manual if any temperature readout falls outside the normal range.

Inlet Air Temperature—If the inlet air temperature falls outside the normal range, the dryer may fail to achieve the required dew point. Check the compressor aftercooler and adjust aftercooler operation to ensure specified inlet air temperature to the dryer.

Refrigerant Suction Temperature—If the dryer has been operating for more than 20 minutes and the refrigerant suction light flashes, there may be a malfunction in the refrigeration system. Turn the dryer off and have a refrigeration mechanic identify and correct the malfunction. If the dryer is under warranty, call your local distributor for authorization before servicing.

Refrigerant Discharge Temperature—This temperature is used by service personnel to analyze the performance of the refrigeration system.

Ambient Air Temperature—If the ambient air temperature falls outside the acceptable range the dryer may fail to achieve the required dew point or dryer shutdown may result due to high refrigerant discharge pressure.

Intermediate Air Temperature

This temperature is used by service personnel to analyze the performance of the refrigeration system. Intermediate air temperature is displayed by putting monitor in Scan mode then pushing and holding down the TIME ADJUST and CLOSED/OPEN buttons simultaneously for three seconds. The intermediate air temperature will be displayed for 30 seconds. The digital display will then return to its last temperature readout.

Intermediate air temperature varies with operating conditions and ambient air temperature. Table 4 lists approximate normal ranges of this temperature at various inlet flows and dew point classes.

Table 5
AIR AND REFRIGERANT TEMPERATURES

| DIGITAL DISPLAY | TEMPERATURE PROBE LOCATION | COMMENTS | NORMAL TEMPERATURE RANGE | WARNING SET POINT | ALARM SET POINT |
|-----------------------|---|---|--------------------------|--------------------|--------------------|
| Inlet Air | Inlet air piping | Inlet air temperature varies with changes in aftercooler cooling medium temperature and air compressor unloading. Inlet temperatures higher than 100°F reduce drying capacity. | 40°F – 120°F | 100°F | 120°F |
| Refrigerant Suction | Refrigerant line upstream of compressor | These refrigerant temperatures vary with the refrigeration load and are controlled by refrigeration valve settings. These readings are used primarily by service personnel to analyze refrigeration system performance. | 32°F – 55°F | N.A. | 25°F |
| Refrigerant Discharge | Refrigerant line downstream of compressor | | 140°F – 240°F | N.A. | N.A. |
| Ambient Air | Outside the condenser | Ambient air temperatures higher than 100°F will reduce drying capacity. | 35°F – 120°F | > 100°F/ < 35°F | > 120°F/ < 35°F |
| Intermediate Air | Outside surface of chiller discharge piping | Intermediate air temperature varies with inlet air pressure, ambient temperature and airflow. This reading is used primarily by service personnel to analyze refrigeration system performance. | Variable; see Table 3 | N.A. | N.A. |

Table 4
INTERMEDIATE AIR TEMPERATURE

| DRYER INLET AIRFLOW (% of rated capacity) | APPROXIMATE NORMAL RANGE ^a | |
|--|---------------------------------------|-----------------------------------|
| | Class H dew point (33°F - 39°F) | Class M dew point (50° - 54°F) |
| 80 - 100 | 35°F - 45°F | 50°F - 60°F |
| 50 - 79 | 45°F - 55°F | 60°F - 70°F |
| 25 - 49 | 55°F - 65°F | 70°F - 80°F |
| 10 - 24 | 65°F - 75°F | 80°F - 90°F |
| No airflow | 75°F - 100°F | 90°F - 100°F |

^a Based on 90°F - 100°F dryer inlet air temperature and 100°F ambient air temperature. These ranges are approximate and may vary with changes in inlet air pressure, ambient temperature and inlet airflow.

Remote Alarm Contacts (Optional)

Dry (unpowered) contacts including one normally open set and one normally closed set are provided to signal remote indication if the CHECK OPERATING CONDITIONS or SYSTEM ALARM indicators are activated. The contacts are 2½ Amps max., unfused, and 120/240 VAC max.

AUTOMATIC DRAIN VALVE (ADV)

All dryers are equipped with an electronic drain valve that automatically discharges condensate from the dryer.

Equipment rated 75 scfm through 300 scfm

On models DXR75 through DXR300 not equipped with the optional System Operation Monitor, the ADV and its controls are accessible from the left side of the dryer, behind the removable panel. The ADV has two LED indicators and a test button to help verify operation. Pushing the test button causes the drain port to click open. One LED indicates that power is supplied to the ADV; the other LED indicates that the drain port is open. The power indicator turns off when the drain port opens. If either LED fails to turn on at the proper time, refer to the maintenance section of this manual. If the dryer is under warranty, call your local distributor for authorization before servicing.

ADV operation is controlled by an electronic timer. The drain opening can be set from 0.5 sec to 10 sec. The drain cycle can be set from 0.5 min to 45 min.

All Other Models

On all models equipped with a System Operation Monitor drain valve controls are on the monitor. The ADV controls allow the period of drain opening to be set from 1 second to 10 seconds and the drain closed (cycle) time to be set from 0.5 minutes to 10 minutes. A test push button helps to check ADV operation. When the button is pushed, the drain port clicks open with a clearly audible sound.

To set the drain closed (cycle) time:

The monitor must be in the Scan mode. Press the CLOSED/OPEN button once. The display will show the current setting for the ADV closed time.

Press and hold the TIME ADJUST button. Release the button when the display reads the desired time. The selected time will be locked into memory.

To set the drain open time:

The monitor must be in the Scan mode. If monitor is not already in the mode for adjusting drain closed time, slowly push the CLOSED/OPEN button once. Allow a few seconds for monitor to set up, then push the button a second time. The display will show the current setting for the ADV open time.

Press and hold the TIME ADJUST button. Release the button when the display reads the desired time. The selected time will be locked into memory.

ADV Adjustment

To minimize air losses, the ADV timer should be adjusted to open the drain port just long enough to discharge accumulated condensate. Set the timer so that only air discharges at the end of the open period. Recommended initial settings are a 3-second drain opening and a 3-minute drain closed time (cycle). The separator or filter bowl is likely to fill with water if the drain cycle is too long. If liquid discharges as the port is closing, set the timer for a shorter cycle or a longer opening.

SIZING VERIFICATION

Before operating the dryer, verify that it is accurately sized for your installation.

Refrigerated dryers achieve their required dew point at specified inlet air temperature, pressure and airflow. If operating temperature or pressure is different from specified conditions dew point will vary. Use the following formula to determine allowable flow at operating conditions.

$$\text{Maximum Allowable Flow} = \text{Rated Capacity} \times F_{PT} \times F_D$$

Where:

Maximum Allowable Flow = Maximum flow corrected for operating conditions.

Rated Capacity = Maximum flow at standard rating conditions (see Table 11 for rated capacity).

F_{PT} = Correction factor for inlet pressure different from 100 psig and inlet temperature different from 100°F. See Table 7 for pressure and temperature correction factors.

F_D = Dew point correction factor for dew point different from Class H (33°F-39°F). See Table 6 for dew point correction factors. This correction applies only to DXR Series dryers.

**Table 6
DEW POINT CORRECTION FACTORS
DXR SERIES DRYERS**

| PRESSURE DEW POINT | CORRECTION FACTOR |
|--------------------|-------------------|
| 33°F – 39°F | 1.0 |
| 40°F – 44°F | 1.1 |
| 45°F – 49°F | 1.2 |
| 50°F – 54°F | 1.3 |

**Table 7
PRESSURE/TEMPERATURE CORRECTION FACTORS
DXR SERIES DRYERS**

| INLET AIR TEMPERATURE (°F) | INLET AIR PRESSURE (psig) | | | | | | | | | |
|----------------------------|--------------------------------|------|------|------|------|------|------|------|------|------|
| | 60 | 80 | 90 | 100 | 110 | 125 | 150 | 200 | 220 | 250 |
| | Correction Factor (F_{PT}) | | | | | | | | | |
| 80 | 1.03 | 1.20 | 1.28 | 1.35 | 1.38 | 1.43 | 1.49 | 1.58 | 1.61 | 1.65 |
| 90 | 0.93 | 1.08 | 1.15 | 1.21 | 1.24 | 1.27 | 1.34 | 1.42 | 1.44 | 1.48 |
| 100 | 0.77 | 0.89 | 0.95 | 1.00 | 1.02 | 1.06 | 1.11 | 1.17 | 1.19 | 1.23 |
| 110 | 0.59 | 0.66 | 0.70 | 0.74 | 0.75 | 0.78 | 0.82 | 0.87 | 0.88 | 0.91 |
| 120 | 0.44 | 0.50 | 0.53 | 0.56 | 0.57 | 0.59 | 0.62 | 0.66 | 0.67 | 0.68 |
| 130 | 0.35 | 0.40 | 0.43 | 0.46 | 0.46 | 0.48 | 0.51 | 0.54 | 0.55 | 0.56 |

START-UP

Follow the procedure below to start your dryer. Failure to follow the prescribed start-up procedure will invalidate the warranty. If problems arise during start-up call your local distributor.

1. Turn off the dryer ON/OFF switch.
2. Turn on the main electrical power to the dryer.

Models rated for 180 scfm through 1000 scfm:

The crankcase heater is wired to be on when power is supplied to the dryer. **The crankcase heater must be warmed up for 4 hours before starting the dryer. This warm-up heats the compressor oil and boils off liquid refrigerant to prevent damage to the compressor.**

During the warm-up period:

- Do not turn the dryer switch on.
- Compressed air may flow through the dryer during warm-up but drain valves will not be functional.

After the main electrical power to the dryer has been on for 4 hours the dryer may be started.

To start all dryers:

1. Turn the power switch to ON. The refrigerant compressor will turn on; the HIGH EVAP TEMPERATURE light may turn on. On models equipped with a System Operation Monitor the monitor will turn on and the CHECK OPERATING CONDITIONS indicator may turn on. If the dryer does not start in this way, call your local distributor.

2. Confirm that condensate is discharging from the automatic drain valves.
3. Check ADV timing. See Automatic Drain Valve section for ADV adjustment procedure.
4. Check that the main electrical supply voltage matches the voltage specified on the dryer data plate.
5. Check customer-supplied circuit breakers or fuses. Reset or replace as required.
6. Check proper connection and support of compressed air lines to the dryer; check bypass valving system, if installed.
7. Ensure adequate ventilation for air-cooled dryers.
8. For water-cooled models, check that the water supply is connected to the water regulating valve on the condenser. Confirm that the cooling water supply meets the required flow and temperature (see Table 1).
9. Confirm that the inlet air temperature, pressure and airflow to the dryer meet the specified requirements (see Tables 10 and 11).
10. Confirm that the condensate lines from the automatic drain valve discharges into a collection tank or an environmentally approved disposal system.
11. After 30 minutes of operation, check the HIGH EVAP light or CHECK OPERATING CONDITIONS indicator. If this indicator is lit, turn the dryer off and call your local distributor.
12. If the CHECK OPERATING CONDITIONS indicator has turned off after 30 minutes of operation, check the following temperatures on the System Operation Monitor:
 - Refrigerant discharge (head) temperature should be within the range of 140°F to 220°F.
 - Refrigerant suction temperature should be within the range of 32°F to 55°F.

If either temperature is out of range, see the Field Service Guide for correction.

The dryer is designed to run continuously. Let the dryer run even when the demand for compressed air is interrupted; the dryer will not freeze up. If the supply power has been turned off for more than four hours, supply power to the dryer; warm up the crankcase heater (if applicable) for 4 hours

before starting the dryer to vaporize any accumulated liquid refrigerant from the compressor oil.

SHUTDOWN

When the dryer must be shut down for maintenance or other reasons, use the following procedures.

If electrical repairs must be made:

1. Turn off the power switch.
2. Disconnect the main power supply.
3. Lock out and tag the power supply in accordance with OSHA requirements.

DANGER

Portions of the control circuit remain energized when the power switch is in the OFF position. Disconnect supply power to the dryer before performing maintenance on the electrical system.

If mechanical repairs must be made, vent the internal pressure of the dryer to atmospheric pressure.

Restart the dryer according to the start-up instructions.

MAINTENANCE

DXR Series dryers require little maintenance for satisfactory operation. Good performance can be expected if the following routine maintenance steps are taken.

DANGER

Dismantling or working on any component of the compressed air system under pressure may cause equipment failure and serious personal injury. Before dismantling any part of the dryer or compressed air system, completely vent the internal pressure to the atmosphere.

General

For continued good performance of your refrigerated dryer, all refrigeration system maintenance should be per-

med by a competent refrigeration mechanic. Before corrective maintenance is done during the warranty period, call your local distributor and proceed according to instructions. Refer to the warranty for limits of your coverage.

Daily Maintenance

Check the operation of the automatic drain valve at least once during each 8-hour shift. See the Field Service Guide for remedies to ADV malfunctions. See the Instrumentation section for ADV adjustment.

For models with the System Operation Monitor, check the following readouts.

- high evaporator temperature
- refrigerant suction temperature
- refrigerant discharge temperature
- alarm lights

Refer to the Instrumentation section and the Field Service Guide for further information.

Monthly Maintenance

For air-cooled condensers, inspect the condenser coils. Remove dust, dirt or other particles with a soft brush or with compressed air from an OSHA-approved air nozzle that limits its discharge pressure to 30 psig. If the coils are coated with oil, grease or other substances that reduce the cooling efficiency, clean the coil.

Service Due Indicator

On systems equipped with the System Operation Monitor the blue SERVICE DUE indicator will light after 4,500 hours (six months) of dryer operation. At this time, complete the following:

- Disassemble and clean automatic drain valve.
- Disassemble and clean separator bowl.
- For air-cooled condensers, inspect the condenser coils; clean if necessary. Lubricate fan motors with 20 wt motor oil.
- For water-cooled condensers, clean customer-supplied strainer.

To reset the SERVICE DUE INDICATOR:

1. Turn the power switch to the OFF position.
2. Hold down the PUSH TO TEST and CLOSED/OPEN buttons simultaneously.
3. Turn the power switch to the ON position.
4. Wait two seconds. Release the PUSH TO TEST and CLOSED/OPEN buttons. The indicator is now reset.

Ambient Air Filter

For units equipped with the optional ambient air filter (designated by the suffix F in the model number), inspect the filter element. If necessary, replace the element by lifting it out and slipping in a replacement. See the replacement parts lists for replacement element model numbers.

Returns to Manufacturer

If the dryer or a component of the dryer must be returned to the manufacturer, first call your local distributor for a return authorization number and shipping address. Your distributor will inform you whether the dryer or only a component must be returned. Mark the package with the return authorization number and ship freight prepaid as directed by your local distributor.

Automatic Drain Valve (ADV) Disassembly and Servicing

All DXR Series dryers have a timer-controlled automatic drain valve. The valve body is mounted on the frame bottom; a hose connects the valve body to the separator.

CAUTION

Do not disassemble ADV timer or attempt to repair electrical parts. Replace timer if defective.

The ADVs discharge condensate through a full-port drain opening. The valve body may need to be cleaned under conditions of gross particulate contamination.

To disassemble the ADV valve body for cleaning or other maintenance:

1. Turn power switch off.
2. Disconnect main power supply to dryer.

3. Lock out and tag power supply in accordance with OSHA requirements.

WARNING

If power supply is not disconnected before disassembly, serious personal injury and valve damage may result.

4. Remove hoses that connect the ADV to the separator.
5. Remove screw and washer from front of ADV.
6. Remove the power supply connector and gasket (with the timer assembly if attached) from the solenoid coil housing. Do not damage or lose the gasket.
7. Remove 13mm nut and spring washer from top of solenoid coil housing.
8. Lift solenoid coil housing off solenoid core in valve body.
9. Unscrew solenoid core from valve body.

Once the ADV is disassembled, the following maintenance can be performed.

1. Inspect diaphragm; clean or replace as required.
2. Remove debris from valve body.
3. Wipe solenoid core components with a clean cloth or blow out debris with compressed air from an OSHA-approved air nozzle that limits its discharge pressure to 30 psig.
4. Check that small port in diaphragm assembly is clear and solenoid coil moves freely in housing. Viton diaphragm seals are compatible with commonly used synthetic lubricants.
5. If timer is attached to valve body, check electrical continuity across timer assembly.

To reassemble the ADV, reverse the sequence of the preceding steps. After the ADV is reassembled, connect the main power supply to the dryer. When the dryer is returned to service, check the ADV for air or condensate leaks; tighten connections as required to correct leaks. Check the drain cycle; adjust the timer according to the procedure in the ADV Adjustment section.

FIELD SERVICE GUIDE

Problems most frequently encountered with refrigerated dryers are water downstream of the dryer and excessive pressure drop. Most causes can be identified and remedied by following this guide.

DANGER

Closed refrigeration systems are potentially dangerous. Work on the refrigeration system must be done only by a competent refrigeration mechanic.

Do not release fluorocarbon refrigerants indoors; do not discharge liquid refrigerants into floor drains. Refrigerant vapors may accumulate in low places. Inhalation of high concentrations may be fatal.

Do not smoke while working on the refrigeration system or when a refrigerant leak is suspected. Burning materials may decompose refrigerants, forming toxic gas or acids that may cause serious injury and property damage.

The refrigerant valves are adjusted at the factory with the refrigerant system operating and no airflow through the dryer. While the dryer is operating, the suction pressure/temperature may fluctuate slowly with changes in the refrigeration load. To determine the suction pressure/temperature, a refrigeration mechanic should attach a set of gauges to the unit. Gauge readings should be as follows:

**Table 8
SUCTION PRESSURE/TEMPERATURE**

| REFRIGERANT | WITHOUT AIRFLOW | WITH AIRFLOW |
|-------------|-----------------|--------------|
| R134a | 30 psig/33°F | 35 psig/40°F |
| R22 | 58 psig/33°F | 68 psig/40°F |

Do not adjust refrigerant valves without factory authorization. Adjustments must be made only with no airflow into the dryer.

CAUTION

Do not introduce mineral oils into the refrigeration system of DXR Series dryers models DXR75 and DXR100. Servicing equipment should contain **NO TRACE OF MINERAL OILS**. Use only polyol esters (POEs) approved for use with R134a refrigerant.

**Table 9
REFRIGERANT PRESSURE SWITCH SETTINGS**

| Fan Cycle Control | | | | |
|----------------------------------|-------|-----|-----|-----|
| Pressure Switch Setting | | | | |
| Model | R134a | | R22 | |
| | On | Off | On | Off |
| DXR75 | 225 | 150 | NA | NA |
| DXR100 | | | | |
| DXR140 | NA | | 225 | 150 |
| DXR180, DXR230 DXR300A | | | 275 | 195 |
| DXR425 DXR550 DXR750, DXR1000 | | | 275 | 195 |

| Refrigerant Compressor Control | | |
|--------------------------------|---------|--------|
| Pressure Switch Setting | | |
| Sensor Location | R22 | |
| | Cut out | Cut In |
| Compressor Discharge | 405 | 280 |
| Compressor Suction | 40 | 60 |

FIELD SERVICE GUIDE

| PROBLEM | SYMPTOM(S) | POSSIBLE CAUSE | REMEDY |
|----------------------------|--|--|---|
| Water downstream of dryer. | No discharge from automatic drain valves (ADV's). | ADV failure or accumulation of dirt in ADV. | Dismantle ADV; clean, repair or replace. See Maintenance section. |
| | Inlet air temperature is outside normal range or reaches alarm set point. | Aftercooler malfunction. | Check aftercooler discharge temperature. Reduce temperature to 120°F max.; reduce airflow if temperature is above 100°F. (See Sizing Verification.) |
| | Liquid water entering dryer. | Aftercooler drain valve malfunction. | Dismantle aftercooler drain valve; clean, repair or replace. |
| | Excessive airflow (may also cause high pressure drop). | Dryer improperly sized. | Check airflow and dryer capacity (see Table 8). Reduce airflow or resize and replace dryer. |
| | Refrigerant compressor cut out by high refrigerant discharge pressure control. | 1. Condenser fouled or clogged. | 1. Clean condenser coils (see Maintenance, Monthly). |
| | | 2. Fan motor stopped. | 2. Repair or replace fan motor. |
| | | 3. Inlet air temperature too high. | 3. Check aftercooler discharge temperature. Reduce temperature to 120°F max.; reduce airflow if temperature is higher than 100°F (see Airflow section). |
| | | 4. Air in refrigeration system. | 4. Have refrigeration mechanic locate and repair leak. Recharge. Refer to data plate for refrigerant type and quantity. |
| | | 5. Ambient air temperature too high for air-cooled compressor. | 5. Vent compressor room to outside. |
| | | 6. Aftercooler coolant air blowing on air-cooled condenser. | 6. Baffle or vent to outside air. |
| | Compressor cuts out on internal overload. | 1. Inadequate ventilation of air-cooled compressor. | 1. Ensure adequate ventilation of the condensing unit (see Clearance). Motor will re-start automatically when compressor is cool. |
| | | 2. Insufficient cooling water for water-cooled compressor. | 2. Ensure adequate cooling water (see Table 1). Motor will re-start automatically when compressor is cool. |
| | | 3. Leak in refrigeration system. | 3. Locate leak. Repair and recharge. Motor will re-start automatically when compressor is cool. |
| | | 4. Incorrect adjustment of refrigeration control valves. | 4. Call your local distributor. |
| | Compressor windings read open or shorted. | Compressor burned out. | Have refrigeration mechanic check and replace. |
| HIGH EVAP light on. | 1. Leak in refrigeration system. | 1. Locate leak; repair and recharge. | |
| | 2. Improper adjustment of HGBV. | 2. Remove cap from HGBV and screw out HGBV 1/2 turn with an allen wrench to lower suction temperature to the level listed in the Refrigerant Flow section. | |
| | 3. Air or noncondensables in refrigeration system. Possible leak in chiller. | 3. Locate leak; repair and recharge. If chiller must be replaced, consult your local distributor. | |

| PROBLEM | SYMPTOM(S) | POSSIBLE CAUSE | REMEDY |
|---|--|---|---|
| Water downstream of dryer. | Suction temperature higher than 65°F. | 1. Improper adjustment of HGBV. | 1. Remove cap from HGBV and screw out HGBV ½ turn with an allen wrench to lower suction temperature to the level listed in the Refrigerant Flow section. |
| | | 2. Inlet air temperature higher than 130°F. | 2. Reduce aftercooler discharge temperature to design conditions (130°F max.). |
| | | 3. Excessive airflow | 3. Check airflow and system capacity. Reduce airflow or resize and replace system. |
| | | 4. Leak in refrigeration system. | 4. Locate leak; repair and recharge. |
| | Refrigerant discharge temperature lower than 140°F. | Low ambient temperature. | Consult your local distributor. |
| | Refrigerant discharge temperature higher than 250°F. | 1. Condenser fouled or clogged. | 1. Clean or replace condenser. |
| | | 2. Fan motor inoperative (air-cooled condensers only). | 2. Replace fan motor. |
| | | 3. Incorrect fan cycling switch setting (air-cooled condensers only). | 3. Consult your local distributor. |
| | | 4. Inlet air temperature too high. | 4. Check temperature of inlet air. Reduce to design conditions. |
| | | 5. High ambient temperature. | 5. Ventilate area. |
| 6. Incorrect water valve adjustment (water-cooled condensers only). | | 6. Adjust water valve to 210 psig. To decrease the pressure, turn the slotted square extension on the water regulating valve (at the compressor inlet) clockwise, increasing the water flow. To increase the pressure, turn the extension counterclockwise. | |
| High pressure drop across dryer. | Inlet air temperature lower than 40°F. | Low ambient temperature. | Turn off dryer until ambient temperature exceeds required pressure dew point. |
| | Excessive airflow (may also cause water downstream of dryer). | Dryer improperly sized. | Check airflow and dryer capacity (see Table 8). Reduce airflow or resize and replace dryer. |
| | Dryer icing up. | Suction temperature lower than 32°F. | Adjust HGBV clockwise to raise to 33°F. Bypass the dryer while adjusting. |
| | Intermediate air temperature below 32°F. | Dryer icing up. | 1. Adjust operating conditions to meet sizing conditions. 2. Adjust HGBV to raise suction temperature to the level listed in the Refrigerant Flow section. |
| High suction temperature. | Intermediate air temperature too high. Frosting of compressor or no cooling. Refrigerant suction temperature too high. | 1. Loss of refrigerant charge. Refrigerant compressor cycles on low pressure control. | 1. Locate leak. Repair and recharge. |
| | | 2. Refrigerant filter/dryer plugged up. | 2. Replace filter/dryer. |
| High suction temperature. | Refrigerant discharge temperature higher than 220°F. Refrigerant suction temperature higher than 65°F. | Water in refrigeration system. Leak in chiller or water-cooled condenser. | Locate leak. Repair leak or replace chiller or condenser. |

| PROBLEM | SYMPTOM(S) | POSSIBLE CAUSE | REMEDY |
|---|---|---|--|
| Intermediate air temperature too high. | High suction temperature. | 1. Loss of refrigerant charge. Refrigerant compressor cycles on low pressure control. | 1. Locate leak. Repair and recharge. |
| | | 2. Refrigerant filter/dryer plugged up. | 2. Replace filter/dryer. |
| No condensate from automatic drain valve (ADV). | Valve continuously venting. | 1. Clogged diaphragm. | 1. Clean diaphragm. |
| | | 2. Short in electrical component. | 2. Check and replace connector or timer assembly. |
| | Valve not cycling | 1. No electrical power. | 1. Check and correct power supply and connections. |
| | | 2. Timer malfunction. | 2. Replace timer assembly. |
| | | 3. Solenoid coil malfunction. | 3. Replace solenoid coil. |
| | | 4. Clogged ports. | 4. Clean ports. |
| | No response when test button is pushed. | 1. No electrical power. | 1. Check and correct power supply and connections. |
| 2. Timer malfunction. | | 2. Replace timer assembly. | |

**Table 10
DIMENSIONS AND CONNECTION SIZES**

| MODEL NO. | MAX OPERATING PRESSURE (PSIG) | DIMENSIONS (inches) | | | IN-OUT CONNECTIONS (in NPT) |
|-----------|-------------------------------|---------------------|----|----|-----------------------------|
| | | W | H | D | |
| DXR75 | 250 | 35 | 35 | 21 | 1¼ |
| DXR100 | 250 | 35 | 35 | 21 | 1½ |
| DXR140 | 250 | 35 | 39 | 21 | 2 |
| DXR180 | 250 | 34 | 40 | 36 | 2 |
| DXR230 | 250 | 34 | 40 | 36 | 2½ |
| DXR300 | 250 | 34 | 40 | 36 | 2½ |
| DXR425 | 250 | 36 | 64 | 36 | 3 |
| DXR550 | 250 | 36 | 64 | 36 | 3 |
| DXR750 | 250 | 36 | 73 | 48 | 3 |
| DXR1000 | 250 | 36 | 73 | 48 | 3 |

**Table 11
DRYER SPECIFICATIONS**

| DRYER MODEL | RATED CAPACITY ^a (scfm) | POWER SUPPLY (V/0/Hz) | ALLOWABLE VOLTAGE RANGE | | REFRIGERANT COMPRESSOR RATING (HP) | INPUT POWER (KW) | REFRIGERANT TYPE ^b |
|-------------|---------------------------------------|--------------------------|-------------------------|-----|------------------------------------|------------------|-------------------------------|
| | | | Min | Max | | | |
| DXR75 | 75 | 115/1/60 | 104 | 126 | 1/3 | .76 | R134a |
| | | 208-230/1/60 | 198 | 253 | 1/3 | | |
| DXR100 | 100 | 115/1/60 | 104 | 126 | 1/2 | .88 | R134a |
| | | 208-230/1/60 | 198 | 253 | 1/2 | | |
| | | 460/1/60 | 414 | 506 | 1/2 | | |
| DXR140 | 140 | 115/1/60 | 104 | 126 | 3/4 | 1.01 | R22 |
| | | 208-230/1/60 | 198 | 253 | 3/4 | | |
| | | 460/1/60 | 414 | 506 | 3/4 | | |
| DXR180 | 180 | 208-230/1/60 | 198 | 253 | 1 | 1.64 | R22 |
| | | 460/3/60 | 414 | 506 | 1 | | |
| DXR230 | 230 | 208-230/1/60 | 198 | 253 | 1 1/2 | 2.20 | R22 |
| | | 208-230/3/60 | 198 | 253 | 1 1/2 | | |
| | | 460/3/60 | 414 | 506 | 1 1/2 | | |
| DXR300 | 300 | 208-230/1/60 | 198 | 253 | 1 1/2 | 2.20 | R22 |
| | | 208-230/3/60 | 198 | 253 | 1 1/2 | | |
| | | 460/3/60 | 414 | 506 | 1 1/2 | | |
| DXR425 | 425 | 208-230/3/60 | 198 | 253 | 2 | 2.73 | R22 |
| | | 460/3/60 | 414 | 506 | 2 | | |
| | | 575/3/60 | 518 | 632 | 2 | | |
| DXR550 | 550 | 208-230/3/60 | 198 | 253 | 3 | 3.46 | R22 |
| | | 460/3/60 | 414 | 506 | 3 | | |
| | | 575/3/60 | 518 | 632 | 3 | | |
| DXR750 | 750 | 208-230/3/60 | 198 | 253 | 4 | 5.58 | R22 |
| | | 460/3/60 | 414 | 506 | 4 | | |
| | | 575/3/60 | 518 | 632 | 4 | | |
| DXR1000 | 1000 | 208-230/3/60 | 198 | 253 | 5 | 6.83 | R22 |
| | | 460/3/60 | 414 | 506 | 5 | | |
| | | 575/3/60 | 518 | 632 | 5 | | |

^aRating conditions, in accordance with Recommended Standard NFPA/T3.27.2-1981 (ANSI B93.45M and CAGI Standard No. ADF100 for Class H (33°F-39°F) pressure dew point, are 100°F inlet temperature, 100% inlet relative humidity, 100°F ambient temperature and 5 psi maximum pressure drop.

^b Refer to dryer data plate for refrigerant charge.

REPLACEMENT PARTS

| DESCRIPTION | PART NO. | | | | |
|--|---------------------|---------------------|-------------|-------------|-------------|
| | DXR75A | DXR100 | DXR140 | DXR180 | DXR230 |
| Filter-Drier | 7DE30AM | 7DE30AM | 7DE30AM | 7DE30AP | 7DE30AP |
| Constant Pressure Valve | 7DE305ES | 7DE305ES | NA | NA | NA |
| Expansion Valve | NA | NA | 7DE305DX | 7DE305FA | 7DE305ED |
| Hot Gas Bypass Valve | NA | NA | 31DE128B | 31DE128B | 31DE128B |
| High Evap Light | 7DE130FS | 7DE130FS | 7DE130FS | 7DE130FV | 7DE130FV |
| Power On Light | 7DE130FR | 7DE130FR | 7DE130FR | 7DE130FT | 7DE130FT |
| On-Off Switch | 7DE240JA | 7DE240JA | 7DE240JA | 7DE240JA | 7DE240JA |
| Automatic Drain Valve (ADV) | ADV-1711 | ADV-1711 | ADV-1711 | ADV-1723 | ADV-1723 |
| ADV Repair Kit | 7DE347AB | 7DE347AB | 7DE347AB | 7DE347AB | 7DE347AB |
| ADV Solenoid Coil | 7DE345NT | 7DE345NT | 7DE345NT | 7DE345NV | 7DE345NV |
| ADV Valve Body with Coil | 7DE345NS | 7DE345NS | 7DE345NS | 7DE345NP | 7DE345NP |
| ADV Timer | 7DE270CF | 7DE270CF | 7DE270CF | 7DE270CF | 7DE270CF |
| Compressor 115/60/1 | 7DE40LC | 7DE40LD | 7DE40KZ | NA | NA |
| Compressor 230/60/1 | 7DE40LC | 7DE40LD | 7DE40KZ | 7DE40HB | 7DE40LR |
| Compressor 230/60/3 | NA | NA | NA | NA | 7DE40LV |
| Compressor 460/60/3 | NA | NA | NA | 7DE40LW | 7DE40LT |
| Compressor 460/60/1 | NA | CONSULT DISTRIBUTOR | | NA | NA |
| Transformer 230/60/1 | CONSULT DISTRIBUTOR | | | NA | NA |
| Transformer 460/60/1 | NA | CONSULT DISTRIBUTOR | | NA | NA |
| Condenser (Air-cooled) ^a | 42DE5043A | 42DE5043A | 42DE5043A | 42DE5044A | 42DE5044A |
| Fan Motor ^a | 7DE41VA | 7DE41VA | 7DE41VA | 7DE41VD | 7DE41VD |
| Fan Blades ^a | 7DE41VF | 7DE41VF | DE41VF | 7DE41VG | 7DE41VG |
| Fan Pressure Switch ^a | 7DE60ED | 7DE60ED | 7DE60ED | 7DE60EF | 7DE60EF |
| Condenser (Water-cooled) ^b | NA | NA | NA | 7DE50NS | 7DE50NT |
| Water Regulating Valve ^b | NA | NA | NA | 31DE138A | 31DE138A |
| Ambient Air Filter Element (Option) | 7DE96GB | 7DE96GB | 7DE96GB | 7DE96GD | 7DE96GD |
| Separator (complete) ^d | 7DE220FK | 7DE220FL | 7DE220FM | 7DE220FM | AD20 |
| System Operation Monitor ^c | 42DE5099AD | 42DE5099AD | 42DE5099AD | 42DE5099ED | 42DE5099ED |
| System Operation Monitor (Pyramid 2000) ^c | 42DE5099ADP | 42DE5099ADP | 42DE5099ADP | 42DE5099EDP | 42DE5099EDP |
| Temperature Probe | 42DE9146C | 42DE9146C | 42DE9146C | 42DE9146C | 42DE9146C |

^aOnly for air-cooled models.

^bOnly for water-cooled models.

^cElectrical components listed are for standard voltage units.

REPLACEMENT PARTS

| DESCRIPTION | PART NO. | | | | |
|--|-------------|---------------------|-------------|-------------|-------------|
| | DXR300 | DXR425 | DXR550 | DXR750 | DXR1000 |
| Filter-Drier | 7DE30AP | 7DE30AP | 7DE30AP | 7DE30AQ | 7DE30AQ |
| Expansion Valve | 7DE305ED | 7DE305ET | 7DE305BW | 7DE305EE | 7DE305EE |
| Hot Gas Bypass Valve | 31DE128B | 7DE315AF | 7DE315AF | 7DE315AF | 7DE315AF |
| High Evap Light | 7DE130FV | 7DE130FS | 7DE130FS | 7DE130FS | 7DE130FS |
| Power On Light | 7DE130FT | 7DE130FR | 7DE130FR | 7DE130FR | 7DE130FR |
| On-Off Switch | 7DE240JA | 7DE240JA | 7DE240JA | 7DE240JA | 7DE240JA |
| Automatic Drain Valve (ADV) | ADV-1723 | ADV-1711 | ADV-1711 | ADV-1711 | ADV-1711 |
| ADV Repair Kit | 7DE347AB | 7DE347AB | 7DE347AB | 7DE347AB | 7DE347AB |
| ADV Solenoid Coil | 7DE345NV | 7DE345NT | 7DE345NT | 7DE345NT | 7DE345NT |
| ADV Valve Body with Coil | 7DE345NP | 7DE345NL | 7DE345NL | 7DE345NL | 7DE345NL |
| ADV Timer | 7DE270CF | 7DE270CF | 7DE270CF | 7DE270CF | 7DE270CF |
| Compressor 115/60/1 | NA | NA | NA | NA | NA |
| Compressor 230/60/1 | 7DE40LR | NA | NA | NA | NA |
| Compressor 230/60/3 | 7DE40LV | 7DE40JF | 7DE40KG | 7DE40JH | 7DE40LS |
| Compressor 460/60/3 | 7DE40LT | 7DE40HD | 7DE40KF | 7DE40HF | 7DE40LQ |
| Compressor 575/60/3 | NA | 7DE40HD | 7DE40KF | 7DE40HF | 7DE40LQ |
| Transformer 575/60/3 | NA | 7DE275X | 7DE275X | 7DE275X | 7DE275W |
| Condenser (Air-cooled) ^a | 42DE5044A | CONSULT DISTRIBUTOR | | | |
| in Motor ^a | 7DE41VD | 7DE41VN | 7DE41VN | 7DE41VR | 7DE41VR |
| an Blades ^a | 7DE41VG | 7DE41VP | 7DE41VP | 7DE41VQ | 7DE41VQ |
| Fan Pressure Switch ^a | 7DE60EF | 7DE60EF | 7DE60EF | 7DE60EF | 7DE60EF |
| Condenser (Water-cooled) ^b | 7DE50NT | 7DE50MZ | 7DE50MZ | 7DE50MK | 7DE50MV |
| Water Regulating Valve ^b | 31DE138A | 31DE138A | 31DE138A | 31DE138A | 31DE138A |
| Ambient Air Filter Element (F Option) | 7DE96GD | 7DE96GE | 7DE96GE | 7DE96GC | 7DE96GC |
| Separator (complete) | AD20 | 7DE220DA | 35DE19B | 35DE19B | 35DE19B |
| System Operation Monitor ^c | 42DE5099ED | 42DE5099AD | 42DE5099AD | 42DE5099AD | 42DE5099AD |
| System Operation Monitor (Pyramid 2000) ^c | 42DE5099EDP | 42DE5099ADP | 42DE5099ADP | 42DE5099ADP | 42DE5099ADP |
| Temperature Probe | 42DE9146C | 42DE9146C | 42DE9146C | 42DE9146C | 42DE9146C |

^aOnly for air-cooled models.

^bOnly for water-cooled models.

^cElectrical components listed are for standard voltage units.

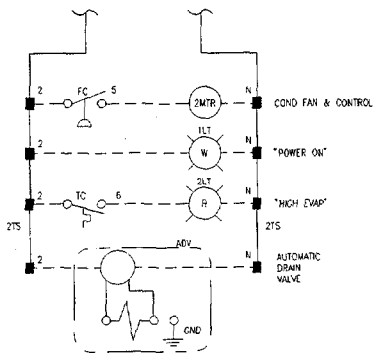
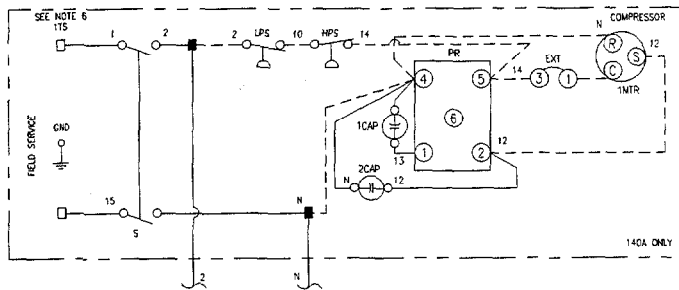
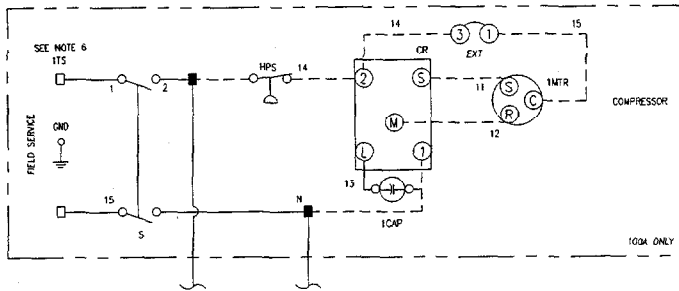
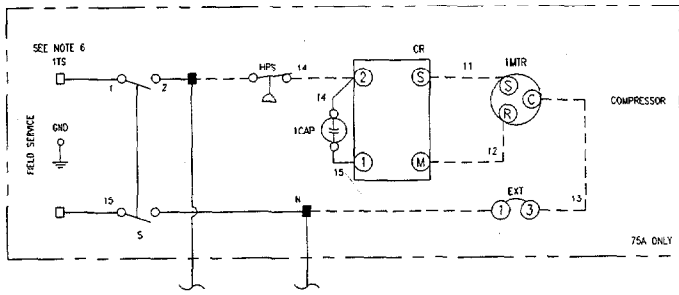

SCHEMATIC FOR STANDARD DRYER

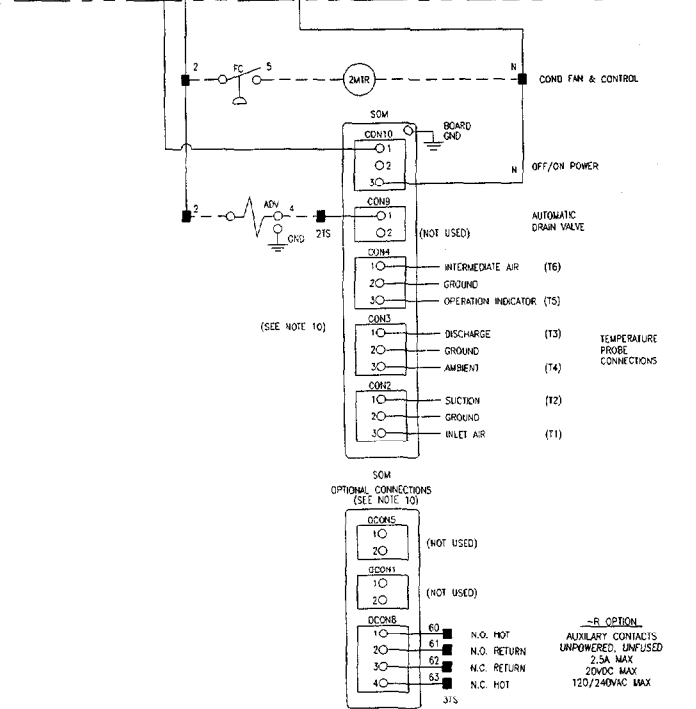
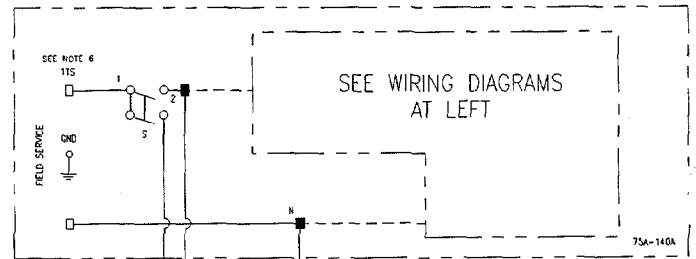

SCHEMATIC FOR DRYER WITH 'T' OPTION

Figure 3a.
Electrical schematic models DXR75 through DXR140.

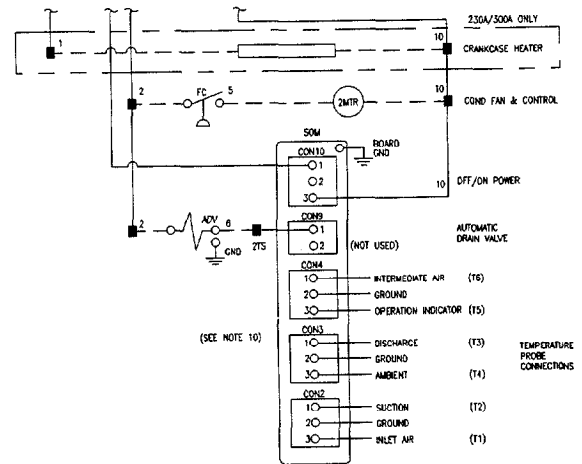
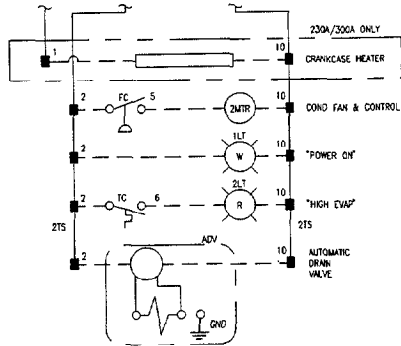
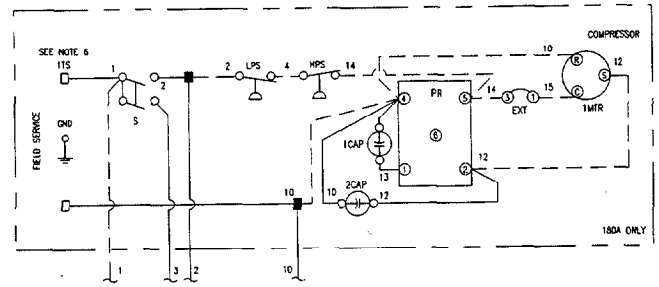
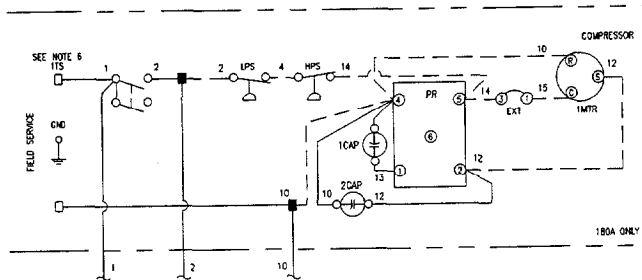
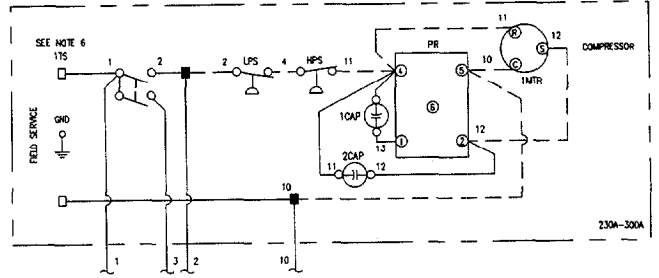
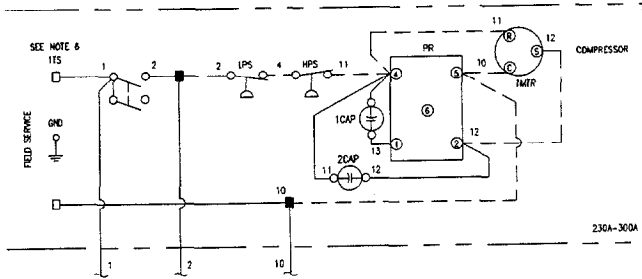

SCHEMATIC FOR STANDARD DRYER

SCHEMATIC FOR DRYER WITH 'T' OPTION

Figure 3b.
Electrical schematic models DXR180 through DXR300.

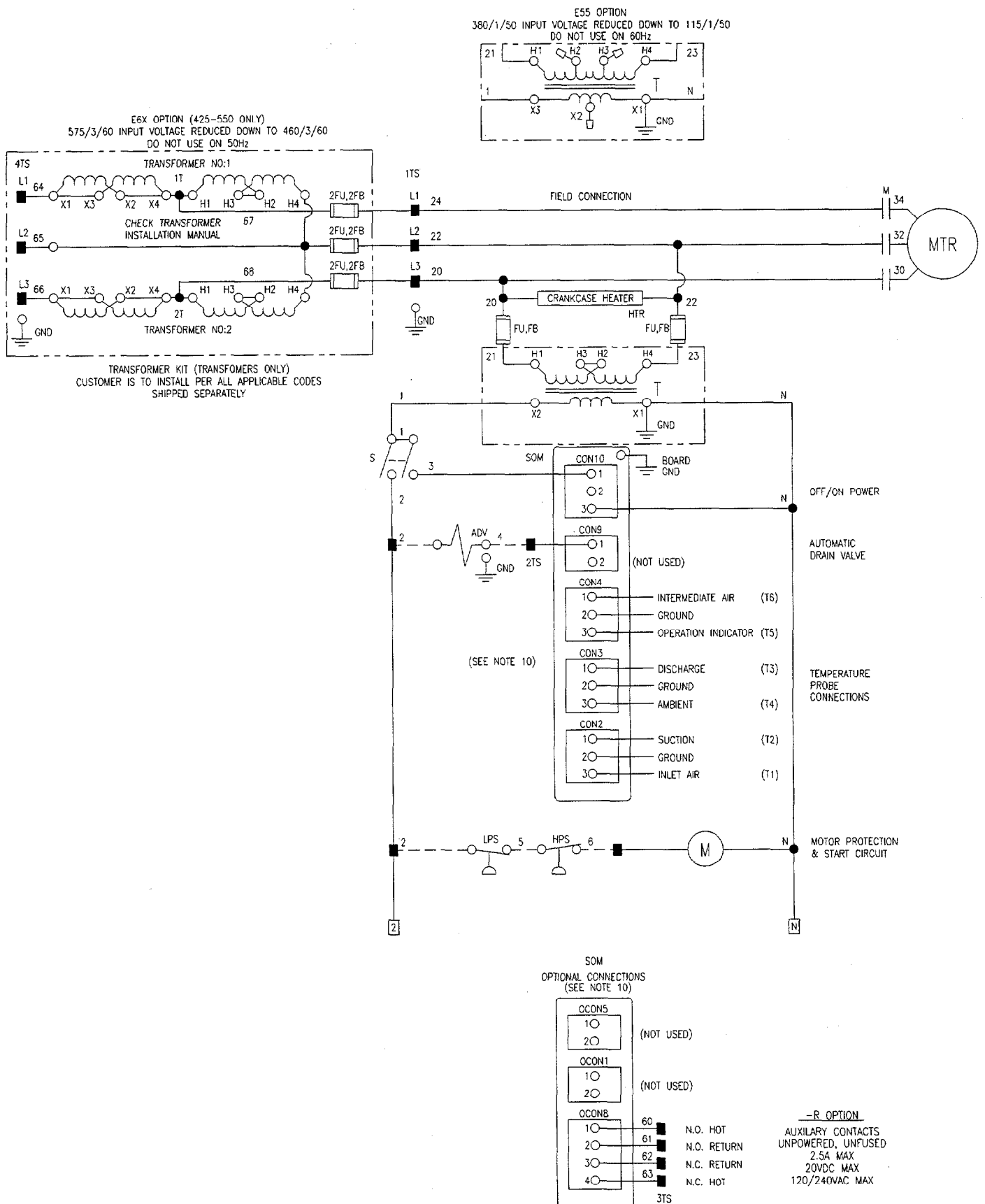

Figure 3e.
Electrical schematic models DXR425-W through DXR1000-W.

INGERSOLL RAND AIR COMPRESSOR

lecomair.wp

Site location: Camp Lejeune, OU2, N.C.
Date service man on site: February 6 & 7, 1996
Name of service man: Mr. Walt Warren, 1-800-331-8091

Questions & Comments:

1. Question: Should the air compressor be run continuously?

Comments: Normal usage of compressed air in the water treatment plant is approximately 12 cfm. The air compressor is designed for 100 cfm total from the two air compressors. The air compressor can be run in intermittent operations instead of continuous. If the air compressor cycles more than 6 times per hour, then the compressor should be run in the continuously mode.

2. Question: How do you make the compressor run continuously?

Comments: This can be done by turning the set screw on the auxiliary brass valve (located behind the pressure gauge directly underneath the air compressor crankcase). Turning clockwise all the way down will make the compressor run intermittently, and "on" and "off" regulated by tank pressure.

Turning the set screw counterclockwise all the way up allows the compressor to run continuously. If the air tank is full, the air compressor will stop, but the motor will keep running under the continuous mode.

3. Question: Will the two air compressors come on together?

Comments: The two air compressors will cycle alternately by a cycle relay. But if the air pressure is really low in the air tank, both compressors will come on together.

4. Question: Do the air compressor need a oil separator?

Comments: There is a coalescent filter at the air dryer outlet to capture the oil. The filter should be drained once a day or once a shift.

5. Question: What are the pressures set at for the compressor to turn on and off?

Comments: The air compressors are set to turn off automatically at 125 psi, and turn on automatically at 80 psi. The "on" pressure can be adjusted by turning the green colored spring inside the regulator box (one for each compressor) up or down. Turning the screw clockwise and

lower the spring downward raises the "on" pressure, and counterclockwise and up to decrease the "on" pressure.

6. Question: What would the compressed air exit temperature be at the compressor discharge?

Comments: The compressed air temperature at the compressor outlet prior to the aftercooler is around 400 deg F. High temperature shut off is set at 500 deg F. If high temperature trips the compressor, it needs to be reset with the 'reset' button located underneath the compressor mounted on the frame. Then press the reset button on the control panel to reset the alarm light.

7. Question: What is the exit air temperature after the air dryer?

Comments: The exit air temperature after the aftercooler is about 100 deg F, and about 95 deg F. after the air dryer. The air dryer cools the air to drop out the moisture and reheats it at the exit.

8. Question: What are the ratings for the compressed air line or 'green' line made by Chemtrol?

Comments: The Chemtrol air lines are rated for 185 psi at 110 deg F. but drops significantly to 100 psi at 140 deg F.

9. Question: What is the pressure relief valve on the air tank set at?

Comments: The pressure relief valve (located behind the control panel) on the air tank is set to open at 135 psi and has demonstrated to do so.

10. Question: What are the lubrication schedules?

Comments: The motor bearings (two on each motor) should be greased once every three months.

The motor oil in the air compressor crankcase should be checked daily with the dip stick. The oil should be changed after the first 500 hours of operation, and every 1,000 hours afterwards. The oil must be re-filled when the low oil level light is illuminated in the panel.

11. Question: What are the pressures for the intercooler and the distance piece?

Comments: The normal pressure for the intercooler is 30 psi, and a max of 60 psi. The normal pressure for the distance piece is about 15 psi.

12. Question: Does the air dryer need to be warmed up prior to start up?

Comments: The air dryer needs to be warmed up for 24 hours, by turning the power on, if the dryer has been sitting on a shut down mode for a long time and the unit is cold. Warming the dryer will help to separate the Freon from the motor oil in the crankcase prior to starting the unit up.

13. Question: What should you do when the high evaporator temperature alarm comes on in the dryer?

Comments: When the high evaporator temperature comes on in the dryer, the coil at the front end of the dryer needs to be cleaned.

14. Question: Do you need to drain the water from the air tank?

Comment: The air tank is equipped with an automatic solenoid drain valve that will open automatically. This solenoid valve should be plugged into an outlet. The hand valve upstream of the solenoid should be left on.

TYPE-30

PARTS

LIST

Concentric Ring Valve
Non-Lubricated Cylinder
Type Compressors For
Oil-Free Air

Model **10T3NL**

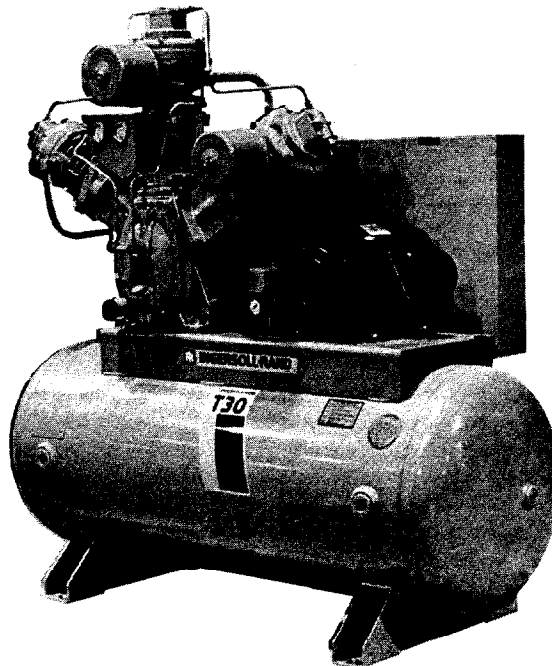

INGERSOLL-RAND®
AIR COMPRESSORS

REFER ALL COMMUNICATIONS TO THE NEAREST
INGERSOLL-RAND SERVICE DISTRIBUTOR.

Form SCD 168-C
November 1988
Supersedes 168B

STATEMENT CONCERNING THE USE OF THIS EQUIPMENT FOR BREATHING AIR AND/OR AQUA LUNG SERVICE.

If the model number on this air compressor contains the letters "BAP", the compressor is suitable for use in breathing air services. In the absence of such a designation, the compressor is NOT considered as capable of producing air of breathing quality. For a compressor to be capable of use in breathing air services, it must be fitted with additional specialized equipment to properly filter and/or purify the air to meet all applicable federal, state and local laws, rules, regulations and codes, such as but not limited to, OSHA 29 CFR 1910.34, Compressed Gas Association Commodity Specifications G-7.1-1966, Grade D Breathing Air, and/or Canadian Standards Association. Should the Purchaser and/or User fail to add such specialized equipment and proceeds to use the compressor for breathing air service, the Purchaser/User assumes all liability resulting therefrom without any responsibility or liability being assumed by Ingersoll-Rand Company.

The Purchaser is urged to include the above provision in any agreement for any resale of this compressor.



Hazardous vapors. Can cause severe nausea, fainting or death.

Compressed air from this air compressor may contain poisonous carbon monoxide.

Certain sprayed material such as paints, insecticides, weed killer, sand, etc., may be harmful if inhaled or used in a closed area.

Never directly inhale the compressed air produced by this air compressor.

Always read labels with containers when spraying paints or poisons.

Always use the compressor in a well ventilated area.

Use a respirator or mask whenever there is a chance that you might inhale anything that you are spraying. If a mask is used, read all the instructions with the mask so that you will know that it will protect you from what you are spraying.



Hazardous voltage. Can cause severe injury or death. (Applies to models powered by electric motors.)

Always disconnect the power supply before doing any maintenance or repair work.

Always connect the power supply to a properly grounded electrical circuit with the specified voltage and fuse protection.

Never use the compressor in the rain, in a wet area or near an explosive atmosphere.



Flammable vapors. Can cause a fire or an explosion, and result in severe injury or death.

Sparks from the motor's electrical contacts can ignite flammable vapors from gasoline, natural gas, or solvents.

Do not operate the air compressor in any areas where explosive or flammable vapors or liquids may exist.



Compressed air has great force.

Over-pressurizing the air receiver can cause the air receiver to rupture or explode, and result in severe injury or death.

Changes to the air receiver structure will cause the air receiver to weaken and can cause the air receiver to rupture or explode, and result in severe injury or death.

Weakening of the air receiver structure caused from internal rusting of the air receiver can cause the air receiver to rupture or explode, and result in severe injury or death.

Air pressure beyond design limits can cause the air receiver to rupture or explode, and result in severe injury or death.

Improper use of air tools or air attachments can cause explosion, and result in severe injury.

The air receiver is protected from over-pressurizing by a safety valve. **DO NOT REMOVE, MAKE ADJUSTMENTS, OR SUBSTITUTIONS FOR THIS VALVE.** Occasionally pull the ring on the safety valve to make sure that the valve operates freely. If the valve is stuck or does not operate smoothly, it must be replaced.

Never drill into, weld to, or change the air receiver in any manner.

Drain water/condensate from the air receiver daily or before each use.

Pressure switch/unloader valve operation is related to motor/engine horsepower, air receiver rating, and safety valve setting. **DO NOT ATTEMPT TO ADJUST, REMOVE, OR BY-PASS THE PRESSURE SWITCH, OR CHANGE AND MODIFY ANY PRESSURE CONTROL RELATED DEVICE**

Do not use any air tools or air attachments without determining the maximum air pressure recommended for that particular air tool or air attachment.

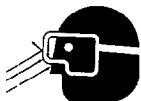

Compressed air. Can propel dirt, sand, metal shaving, etc., and result in severe injury.

Never point any air nozzle or air sprayer toward any part of the body, or toward another person.

Always wear safety glasses or goggles.



Moving parts. can cause severe injury.

The electric motor air compressor models are designed to cycle automatically when the power is ON. During service or repair work, this automatic cycling can cause severe injury.

Always disconnect the power supply on electric motor models before attempting to do any maintenance or repair work to the compressor.

Always disconnect the power supply on electric motor models if the compressor is to be left unattended.

Always make sure that the air pressure is released from the compressor, the air receiver, and all air attachments before doing any maintenance or repair work.

Never operate the compressor with the belt guard assembly removed.

Never operate the compressor with a damaged or broken belt guard assembly.



Hot parts. Air compressors get hot while running, and result in severe burn if touched.

Never touch the bare compressor, the motor/engine, or the discharge tubing during or shortly after operating the compressor.

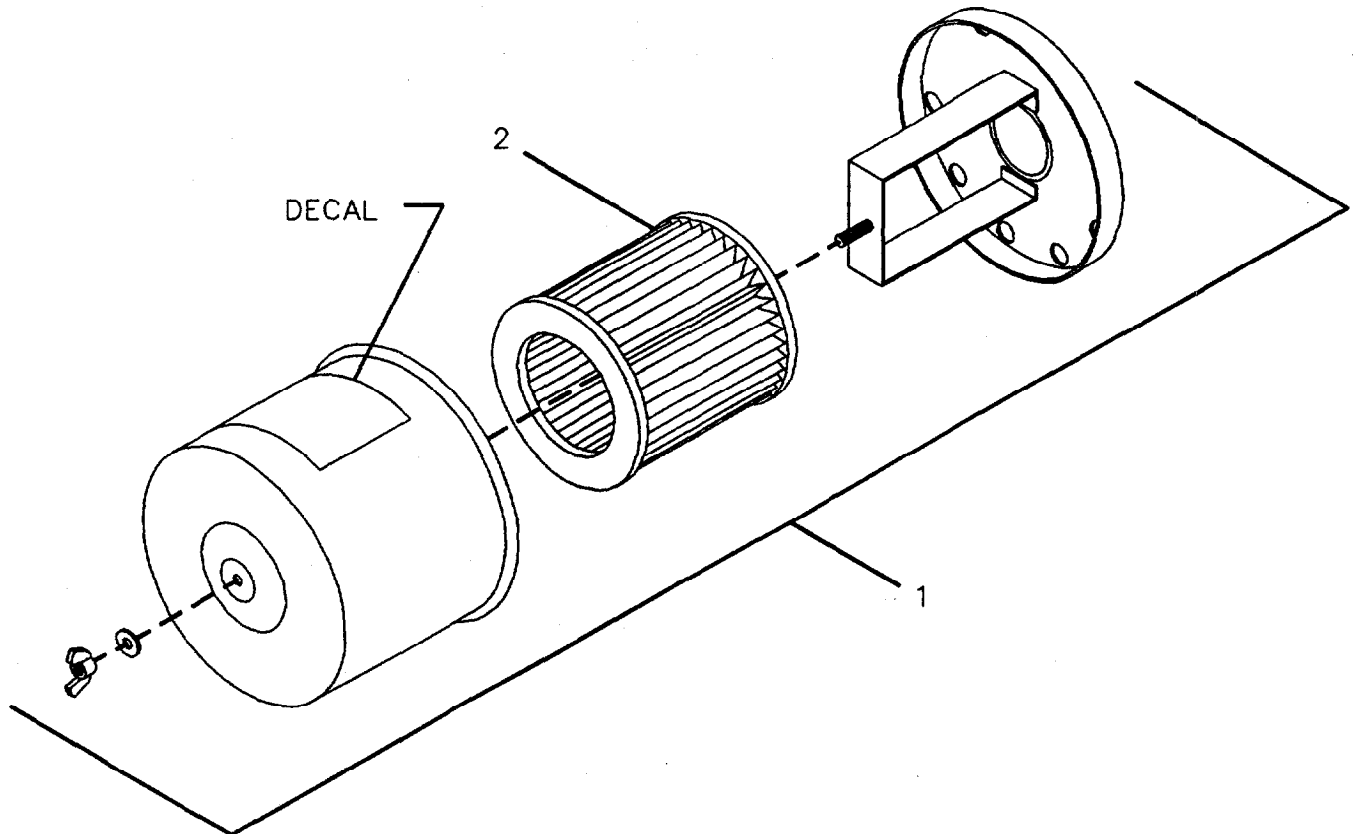

FIGURE 1. INLET FILTER ASSEMBLY

| REF. NBR. | PART NUMBER | DESCRIPTION | UNITS PER ASSY. | REC. SPARES | | |
|-----------|-------------|---|-----------------|-------------|---|---|
| | | | | 1 | 2 | 3 |
| 1-1 | 32109779 | FILTER COMPLETE - INLET | 1 | | | |
| 1-2 | 32012957 | <ul style="list-style-type: none"> ● ELEMENT, FILTER - 10 MICRON <p>IF FILTER ELEMENT IS DESIRED WE RECOMMEND AN ECONOMICAL FILTER KIT. SEE PAGE 17.</p> | 1 | 2 | 2 | 2 |

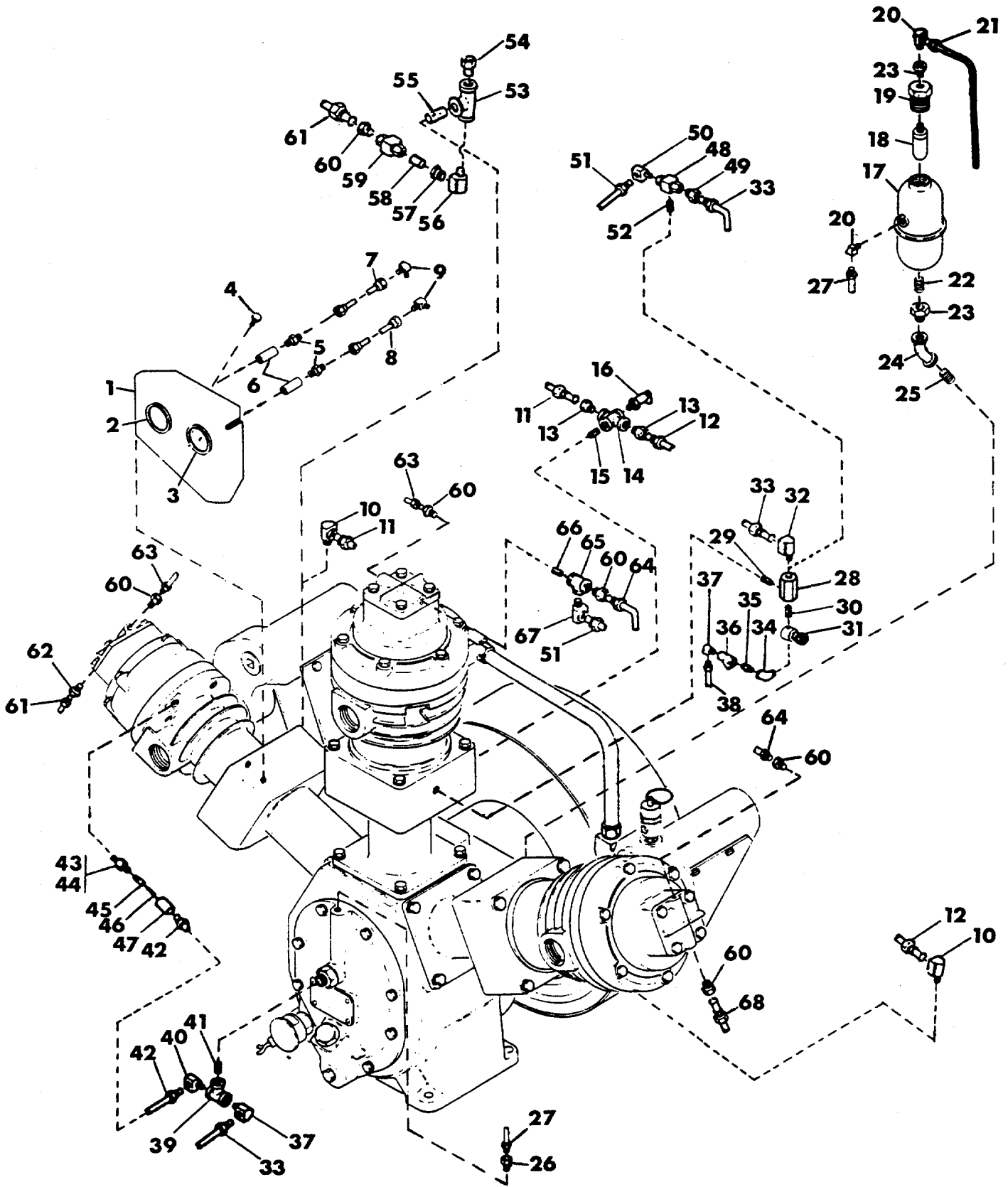

FIGURE 2. MODEL 10T3NL BARE COMPRESSOR

| REF. NBR. | PART NUMBER | DESCRIPTION | UNITS PER ASSY. | REC. SPARES | | |
|--|-------------|---|-----------------|-------------|---|---|
| | | | | 1 | 2 | 3 |
| 2-1 | 37140068 | PANEL—GAUGE | 1 | | | |
| 2-2 | 32020547 | GAUGE—INTERCOOLER PRESSURE | 1 | | | 1 |
| 2-3 | 32020554 | GAUGE—DISTANCE PIECE PRESSURE | 1 | | | 1 |
| 2-4 | 32175572 | CAPSCREW 1/4 X 1/2 | 4 | | | |
| 2-5 | 30640569 | CONNECTOR, MALE 1/8 X 1/8 | 2 | | | |
| 2-6 | 32131674 | COUPLING—PIPE 1/8 IN | 2 | | | |
| 2-7 | 37140225 | TUBE ASM—INTERCOOLER TO GAUGE | 1 | | | |
| 2-8 | 37140233 | TUBE ASM—DISTANCE PIECE TO GAUGE | 1 | | | |
| 2-9 | 32158016 | ELBOW—GAUGE LINE | 2 | | | |
| 2-10 | 95040143 | ELBOW—TUBE | 2 | | | |
| 2-11 | 32059479 | TUBE ASM—BETWEEN CYLINDER DISTANCE PIECES | 1 | | | |
| 2-12 | 32059461 | TUBE ASM—BETWEEN CYLINDER DISTANCE PIECES | 1 | | | |
| 2-13 | 95083143 | CONNECTOR—TUBE | 2 | | | |
| 2-14 | 32127201 | CROSS—PIPE 1/4 IN | 1 | | | |
| 2-15 | 95477667 | NIPPLE—PIPE 1/4 IN | 1 | | | |
| 2-16 | 72062151 | VALVE—SAFETY | 1 | | | |
| 2-17 | 37140316 | TRAP—BREATHER | 1 | | | |
| 2-18 | 37140324 | ELEMENT—BREATHER TRAP | 1 | | | |
| 2-19 | 37140332 | PLUG—BREATHER TRAP | 1 | | | |
| 2-20 | 95110441 | ELBOW—TUBE | 2 | | | |
| 2-21 | 32027294 | TUBE ASM—BREATHER TRAP TO ATMOSPHERE | 1 | | | |
| 2-22 | 95477667 | NIPPLE—PIPE 1/4 IN | 1 | | | |
| 2-23 | 32179046 | BUSHING—REDUCING 3/8 X 1/4 | 2 | | | |
| 2-24 | 95030672 | ELBOW—PIPE 3/8 — 45° | 1 | | | |
| 2-25 | 95691077 | NIPPLE—PIPE 3/8 IN | 1 | | | |
| 2-26 | 32157554 | CONNECTOR—TUBE | 1 | | | |
| 2-27 | 32172579 | TUBE ASM—FRAME END COVER TO BREATHER TRAP | 1 | | | |
| 2-28 | 30220362 | VALVE ASM—UL 100 | 1 | | | |
| 2-29 | 95796017 | NIPPLE—PIPE 1/8 IN | 1 | | | |
| 2-30 | 95426714 | NIPPLE CLOSE 1/4 X 7/8 | 1 | | | |
| 2-31 | 32019770 | REGULATOR (SET AT 25—30 PSI) | 1 | | 1 | 1 |
| 2-32 | 95031860 | ELBOW—TUBE | 1 | | | |
| 2-33 | 32027302 | TUBE ASM—PILOT VALVE TEE TO SHUTTLE VALVE | 1 | | | |
| 2-34 | 95069316 | ELBOW—PIPE STREET 1/4 IN | 1 | | | |
| 2-35 | 95640157 | NIPPLE—PIPE SHORT | 1 | | | |
| 2-36 | 32020372 | FILTER | 1 | | | |
| 2-37 | 95110441 | ELBOW—TUBE | 2 | | | |
| 2-38 | 32170276 | TUBE ASM—STRAINER TO RECEIVER CONTROL PIPING TEE | 1 | | | |
| 2-39 | 95298485 | TEE—PIPE 1/4 IN | 1 | | | |
| 2-40 | 95040143 | ELBOW—TUBE | 1 | | | |
| 2-41 | 95477667 | NIPPLE—PIPE 1/4 IN | 1 | | | |
| 2-42 | 32019598 | TUBE ASM—PILOT VALVE TEE TO RELIEF | 1 | | | |
| 2-43 | 30291801 | VALVE—CYLINDER RELIEF COMPLETE | 1 | | | |
| 2-44 | 35154111 | ● BODY—RELIEF VALVE | 1 | | | |
| 2-45 | 35154129 | ● BARE—RELIEF VALVE | 1 | | | |
| 2-46 | 30672638 | ● SPRING | 1 | | | |
| 2-47 | 30279293 | ● CAP—RELIEF VALVE | 1 | | | |
| NOTE: PARTS LISTED BELOW USED WITH OPTIONAL CONSTANT SPEED OR DUAL CONTROL OPERATION. | | | | | | |
| 2-48 | 37007572 | VALVE—SHUTTLE | 1 | | | 1 |
| 2-49 | 95082483 | CONNECTOR—TUBE | 1 | | | |
| 2-50 | 95031860 | ELBOW—TUBE | 1 | | | |
| 2-51 | 32027336 | TUBE ASM—SHUTTLE VALVE TO C.S. UNLOADER | 1 | | | |
| 2-52 | 95796017 | NIPPLE—CLOSE | 1 | | | |
| 2-53 | 95298485 | TEE—PIPE 1/4 IN | 1 | | | |
| 2-54 | 95083143 | CONNECTOR—TUBE | 1 | | | |
| 2-55 | 95477667 | NIPPLE—PIPE 1/4 IN | 1 | | | |
| 2-56 | 37143542 | ELBOW—PIPE 1/4 IN | 1 | | | |
| 2-57 | 95038030 | BUSHING, REDUCING | 1 | | | |
| 2-58 | 95796017 | NIPPLE—PIPE 1/8 IN | 1 | | | |
| 2-59 | 32001141 | VALVE—CHECK | 1 | | 1 | 1 |
| 2-60 | 95082483 | CONNECTOR—TUBE | 6 | | | |
| 2-61 | 32027344 | TUBE ASM—BETWEEN DISTANCE PIECE AND C.S. UNLOADER | 1 | | | |
| 2-62 | 37144508 | ORIFICE | 1 | | | |
| 2-63 | 32060386 | TUBE ASM—BETWEEN L.P. AND H.P. UNLOADER | 1 | | | |
| 2-64 | 32027567 | TUBE ASM—BETWEEN LOW PRESSURE UNLOADERS | 1 | | | |
| 2-65 | 95063418 | TEE—PIPE 1/8 IN | 1 | | | |
| 2-66 | 95796017 | NIPPLE—PIPE | 1 | | | |
| 2-67 | 95031860 | ELBOW—TUBE | 1 | | | |
| 2-68 | 32170284 | TUBE ASSEMBLY AUXILARY VALVE/CS HEAD | 1 | | | |

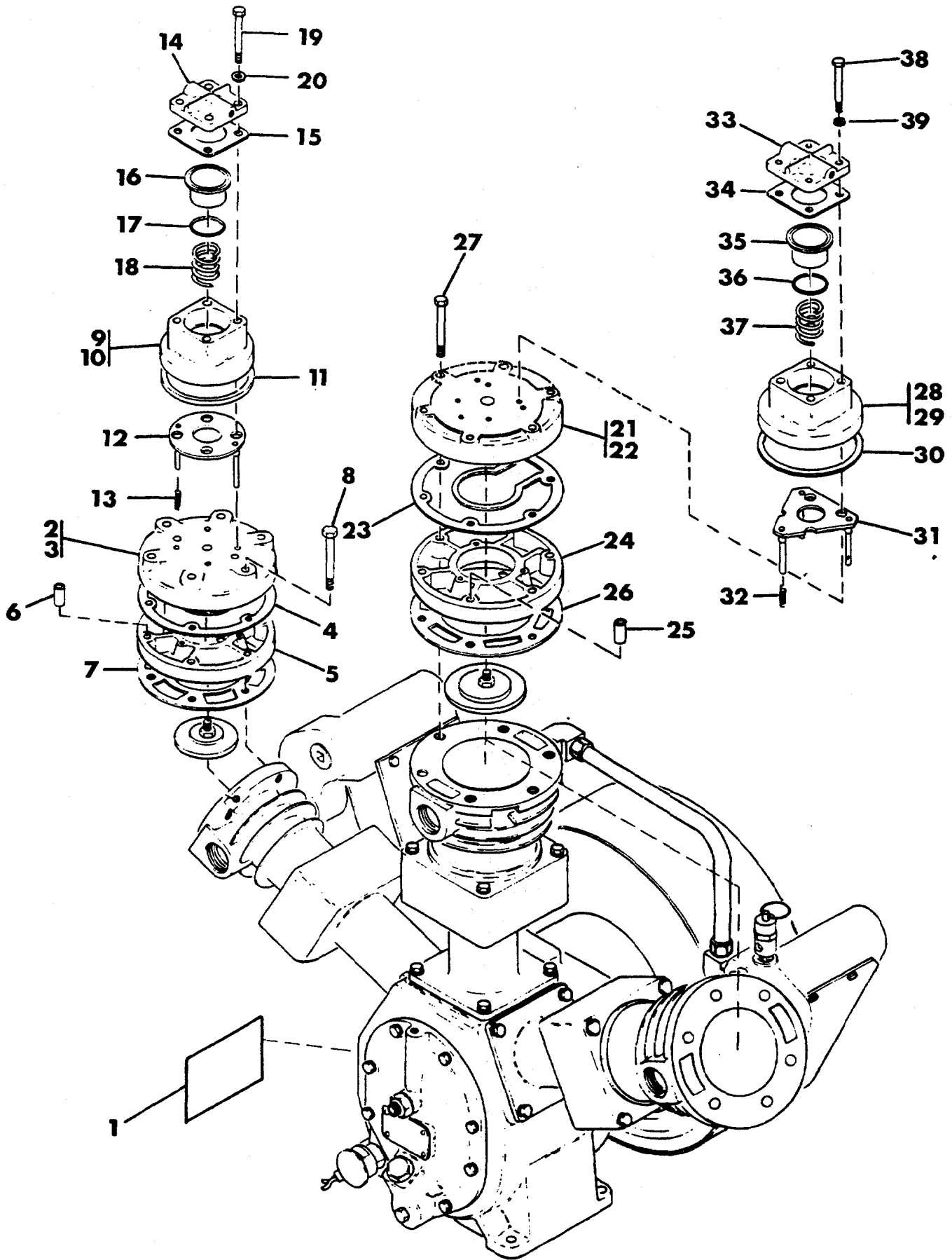

FIGURE 3. MODEL 10T3NL BARE COMPRESSOR

| REF. NBR. | PART NUMBER | DESCRIPTION | UNITS PER ASSY. | REC. SPARES | | |
|-----------|-------------|---|-----------------|-------------|---|---|
| | | | | 1 | 2 | 3 |
| 3-1 | 97003636 | DECAL—DANGER | 1 | | | |
| 3-2 | 37176203 | HEAD—AIR COMPLETE—FOR AUTOMATIC START AND STOP OPERATION | 1 | | | |
| 3-3 | 37130408 | ● HEAD—TOP HALF | 1 | | | |
| 3-2 | 37176211 | HEAD—AIR—COMPLETE—FOR (OPTIONAL) CONSTANT SPEED OR DUAL CONTROL OPERATION | 1 | | | |
| 3-3 | 37130457 | ● HEAD—TOP HALF | 1 | | | |
| 3-4 | 37130432 | ● ● GASKET—BETWEEN HALVES | 1 | 1 | 1 | 2 |
| 3-5 | 37130424 | ● HEAD—BOTTOM HALF COMPLETE | 1 | | | |
| 3-6 | 37114030 | ● ● DOWEL | 1 | | | |
| 3-7 | 30294630 | ● ● GASKET—AIR HEAD TO CYLINDER | 1 | 1 | 1 | 2 |
| 3-8 | 95053054 | ● CAPSCREW 1/2 X 3 | 6 | | | |
| 3-9 | 31117567 | UNLOADER—CONSTANT SPEED—COMPLETE | 1 | | | |
| 3-10 | 37004728 | ● BODY—UNLOADER—COMPLETE | 1 | | | |
| 3-11 | 30294631 | ● ● GASKET—BODY | 1 | 1 | 1 | 2 |
| 3-12 | 32016552 | ● PLATE—UNLOADER | 1 | | | |
| 3-13 | 32012395 | ● SPRING | 2 | | | |
| 3-14 | 30211460 | ● COVER—UNLOADER—COMPLETE | 1 | | | |
| 3-15 | 30294656 | ● ● GASKET—COVER | 1 | 1 | 1 | 2 |
| 3-16 | 30284749 | PISTON—UNLOADER—COMPLETE | 1 | | | |
| 3-17 | 32136715 | ● ● O-RING | 1 | 1 | 2 | 2 |
| 3-18 | 30416853 | ● SPRING | 1 | | | |
| 3-19 | 95102042 | ● CAPSCREW 3/8 X 3 1/2 | 4 | | | |
| 3-20 | 30345227 | ● WASHER—STEEL 3/8 IN | 4 | | | |
| 3-21 | 37101326 | HEAD—AIR—COMPLETE—FOR AUTOMATIC START AND STOP OPERATION | 2 | | | |
| 3-22 | 37130481 | ● HEAD—TOP HALF | 2 | | | |
| 3-21 | 37045861 | HEAD—AIR—COMPLETE—FOR (OPTIONAL) CONSTANT SPEED OR DUAL CONTROL OPERATION | 2 | | | |
| 3-22 | 37130515 | ● HEAD—TOP HALF | 2 | | | |
| 3-23 | 37007747 | ● ● GASKET—BETWEEN HALVES | 2 | 2 | 2 | 4 |
| 3-24 | 37130499 | ● HEAD—BOTTOM HALF—COMPLETE | 2 | | | |
| 3-25 | 37114030 | ● ● DOWEL | 2 | | | |
| 3-26 | 30294193 | ● ● GASKET—AIR HEAD TO CYLINDER | 2 | 2 | 4 | 4 |
| 3-27 | 95053054 | ● CAPSCREW | 12 | | | |
| 3-28 | 30292007 | UNLOADER—CONSTANT SPEED—COMPLETE | 2 | | | |
| 3-29 | 31517709 | ● BODY—UNLOADER—COMPLETE | 2 | | | |
| 3-30 | 30294698 | ● ● GASKET—BODY | 2 | 2 | 4 | 4 |
| 3-31 | 32016537 | ● PLATE—UNLOADER—COMPLETE | 2 | | | |
| 3-32 | 32012395 | ● SPRING | 6 | | | |
| 3-33 | 30211460 | ● COVER—UNLOADER—COMPLETE | 2 | | | |
| 2-34 | 30294656 | ● ● GASKET—COVER | 2 | | | |
| 3-35 | 30284749 | ● PISTON—UNLOADER—COMPLETE | 2 | | | |
| 3-36 | 32136715 | ● ● O-RING | 2 | 2 | 4 | 4 |
| 3-37 | 30416853 | ● SPRING | 2 | | | |
| 3-38 | 95102042 | ● CAPSCREW 3/8 X 3 1/2 | 8 | | | |
| 3-39 | 30345227 | ● WASHER—STEEL 3/8 IN | 8 | | | |
| | | | 1 | | | |

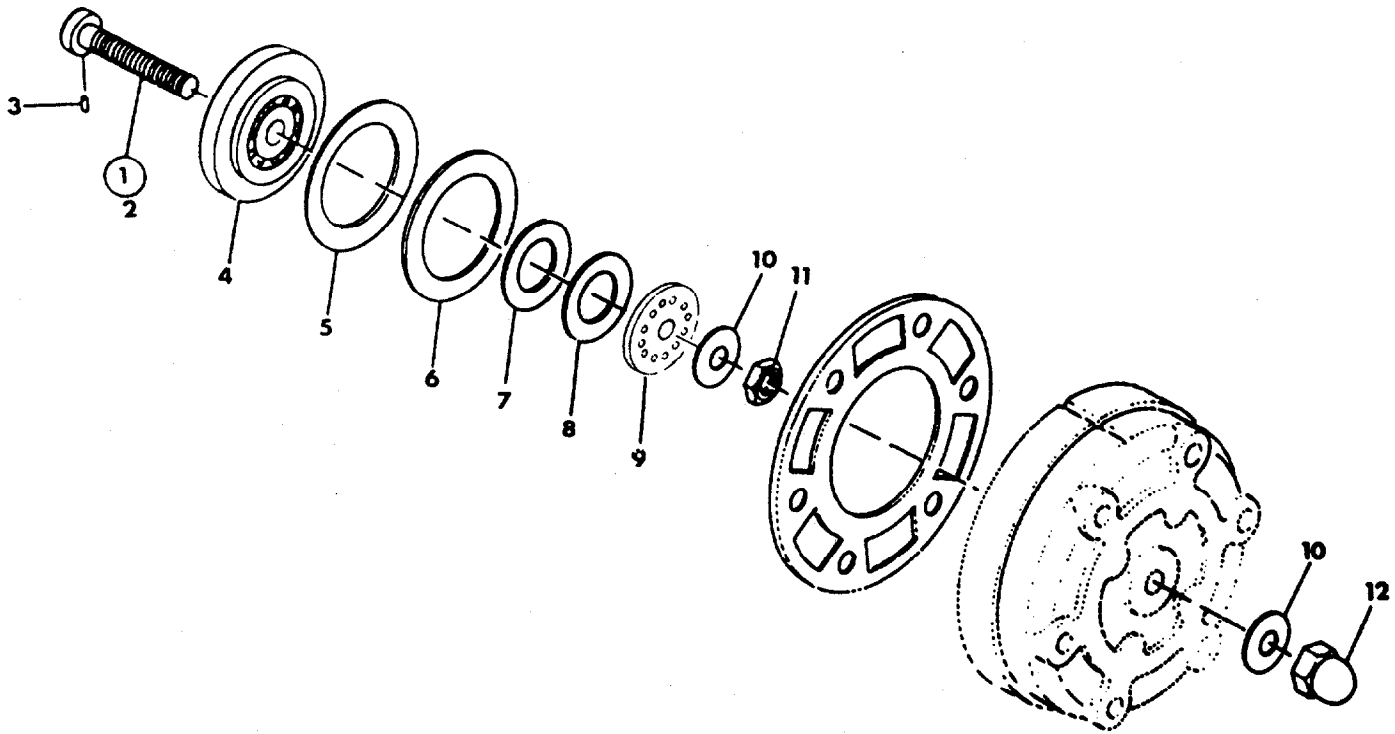

FIGURE 4. 40 GA CONCENTRIC RING VALVE ASSEMBLY

| REF. NBR. | PART NUMBER | DESCRIPTION | UNITS PER ASSY. | REC. SPARES | | |
|-----------|-------------|---|-----------------|-------------|---|---|
| | | | | 1 | 2 | 3 |
| 4-1 | 37004835 | VALVE—COMPLETE | 1 | | 1 | 1 |
| 4-2 | 30220925 | ● BOLT—VALVE | 1 | | | |
| 4-3 | 37002656 | ● ● PIN—BOLT | 1 | | | |
| 4-4 | 30217707 | ● SEAT—DISCHARGE VALVE | 1 | | | |
| 4-5 | 30221527 | ● SPRING—INLET VALVE | 1 | 1 | 1 | 1 |
| 4-6 | 30215859 | ● PLATE—INLET VALVE | 1 | 1 | 1 | 1 |
| 4-7 | 30215917 | ● PLATE—DISCHARGE VALVE | 1 | 1 | 1 | 1 |
| 4-8 | 30221394 | ● SPRING—DISCHARGE VALVE | 1 | 1 | 1 | 1 |
| 4-9 | 30218838 | ● PLATE—DISCHARGE VALVE STOP | 1 | | | |
| 4-10 | 32158644 | ● WASHER—SPRING—BELLEVILLE | 2 | | | 2 |
| 4-11 | 95076808 | ● NUT 5/8—18 | 1 | | | |
| 4-12 | 30287643 | ● NUT—ACORN | 1 | | | |
| | | IF VALVE REPLACEMENT IS DESIRED WE RECOMMEND AN ECONOMICAL VALVE/GASKET KIT. SEE PAGE 17. | | | | |

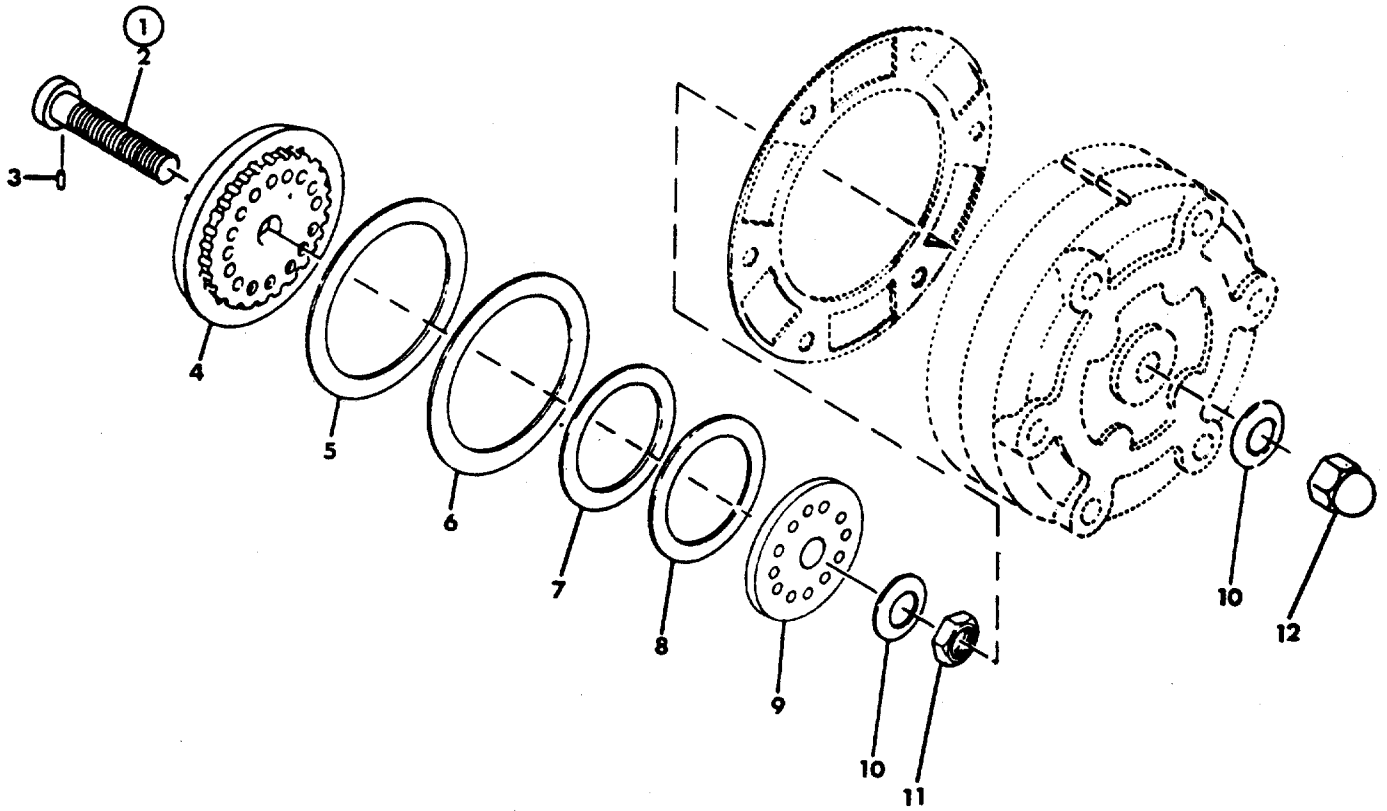

FIGURE 5. 50 GA CONCENTRIC RING VALVE ASSEMBLY

| REF. NBR. | PART NUMBER | DESCRIPTION | UNITS PER ASSY. | REC. SPARES | | |
|-----------|-------------|---|-----------------|-------------|---|---|
| | | | | 1 | 2 | 3 |
| 5-1 | 37004843 | VALVE—COMPLETE | 1 | | 1 | 1 |
| 5-2 | 30279897 | ● BOLT—VALVE | 1 | | | |
| 5-3 | 30289631 | ● ● PIN—BOLT | 1 | | | |
| 5-4 | 30229538 | ● SEAT—DISCHARGE VALVE | 1 | | | |
| 5-5 | 30221550 | ● SPRING—INLET VALVE | 1 | 1 | 1 | 1 |
| 5-6 | 30215891 | ● PLATE—INLET VALVE | 1 | 1 | 1 | 1 |
| 5-7 | 30181499 | ● PLATE—DISCHARGE VALVE | 1 | 1 | 1 | 1 |
| 5-8 | 30221501 | ● SPRING—DISCHARGE VALVE | 1 | 1 | 1 | 1 |
| 5-9 | 30218978 | ● PLATE—DISCHARGE VALVE STOP | 1 | | | |
| 5-10 | 37092897 | ● WASHER—SPRING—BELLEVILLE | 2 | | | 2 |
| 5-11 | 95076816 | ● NUT 3/4—16 | 1 | | | |
| 5-12 | 30287650 | ● NUT—ACORN | 1 | | | |
| | | IF VALVE REPLACEMENT IS DESIRED WE RECOMMEND AN ECONOMICAL VALVE/GASKET KIT. SEE PAGE 17. | | | | |

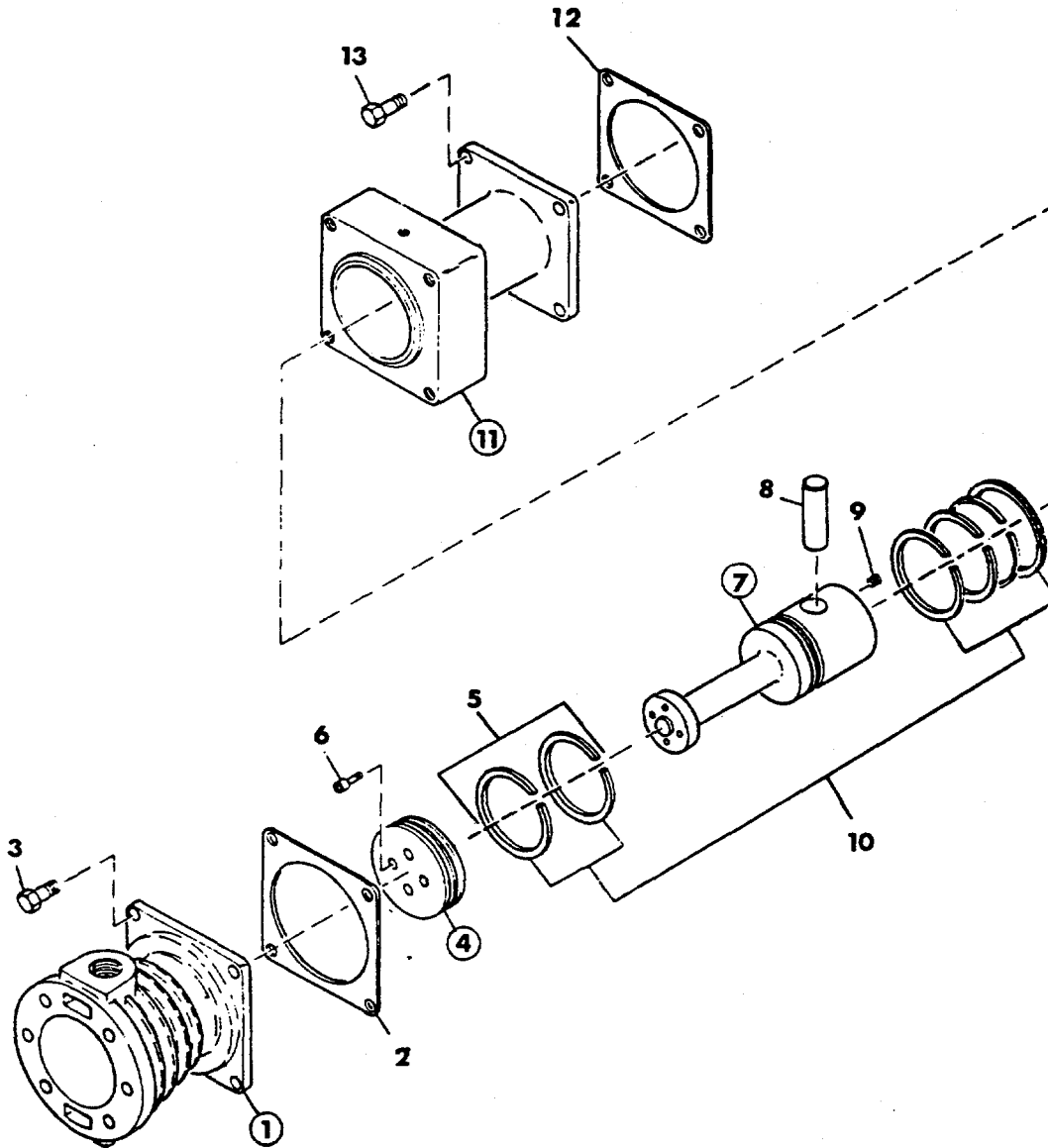

FIGURE 6. 4 1/2 INCH DIAMETER PISTON, CYLINDER AND CROSS HEAD ASSEMBLY

| REF. NBR. | PART NUMBER | DESCRIPTION | UNITS PER ASSY. | REC. SPARES | | |
|-----------|-------------|---|-----------------|-------------|---|---|
| | | | | 1 | 2 | 3 |
| 6-1 | 37154200 | CYLINDER | 1 | | | |
| 6-2 | 37135985 | GASKET | 1 | 1 | 1 | 2 |
| 6-3 | 95053575 | CAPSCREW 1/2 X 1/4 | 4 | | | |
| 6-4 | 37140050 | PISTON | 1 | | 1 | 1 |
| 6-5 | 37139862 | PISTON RING | 1 | 1 | 1 | 2 |
| 6-6 | 95067732 | SCREW—HOLLOW HEX HEAD | 4 | | | |
| 6-7 | 32054488 | CROSSHEAD PISTON ASSY. | 1 | | | |
| 6-8 | 37170271 | ● PIN—CROSSHEAD | 1 | | | |
| 6-9 | 95065678 | SCREW—SET HOLLOW HEAD CUP POINT | 2 | | | |
| 6-10 | 32015125 | SET, RING | 1 | 1 | 1 | 2 |
| 6-11 | 37181146 | GUIDE—CROSSHEAD | 1 | | | |
| 6-12 | 30294201 | GASKET | 1 | 1 | 1 | 2 |
| 6-13 | 95053575 | CAPSCREW 1/2 X 1/4 | 4 | | | |
| | | IF RING REPLACEMENT IS DESIRED WE RECOMMEND AN ECONOMICAL RING/GASKET KIT. SEE PAGE 17. | | | | |

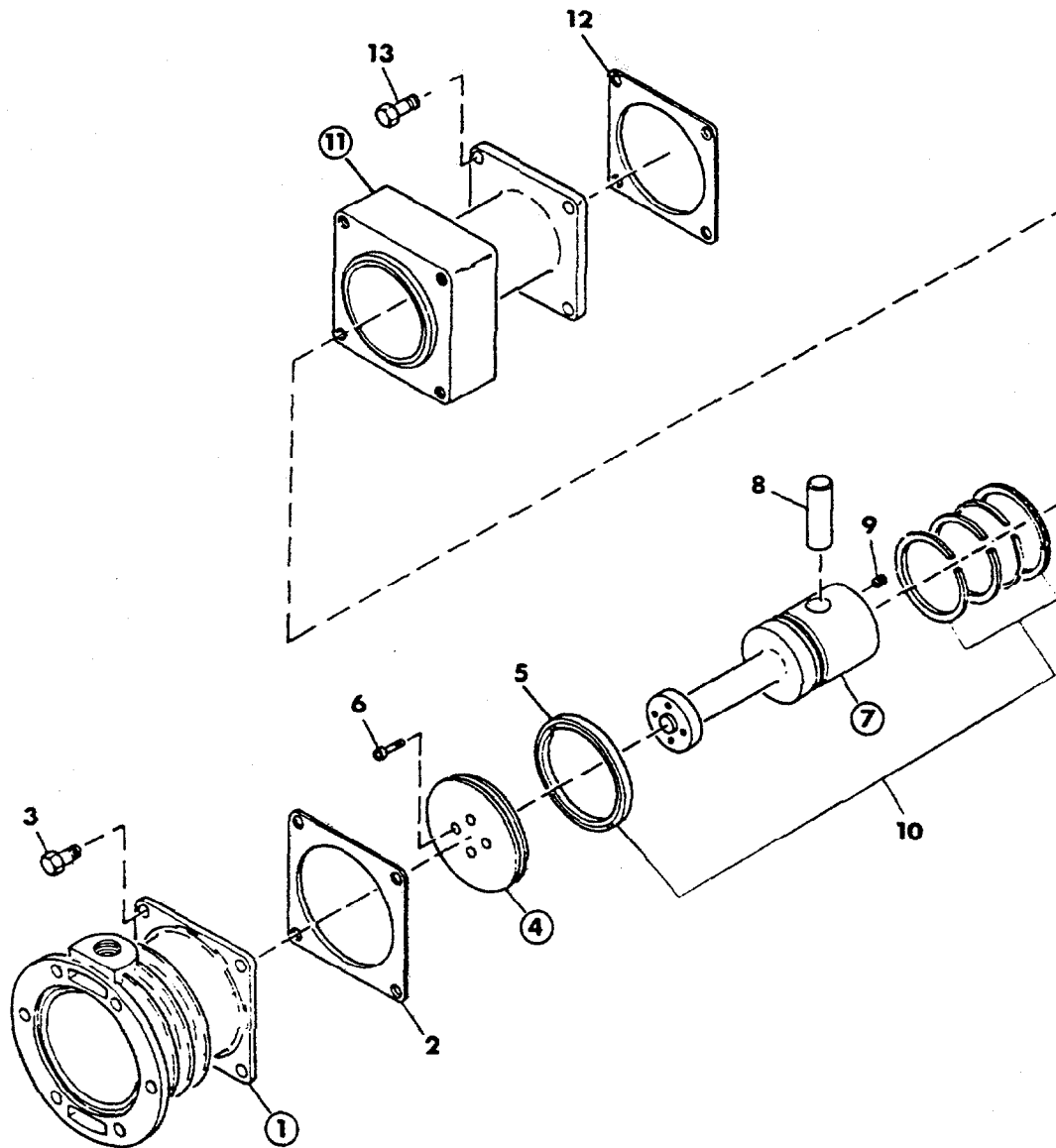

FIGURE 7. 5 INCH DIAMETER PISTON, CYLINDER AND CROSS HEAD ASSEMBLY

| REF. NBR. | PART NUMBER | DESCRIPTION | UNITS PER ASSY. | REC. SPARES | | |
|---|-------------|---------------------------------|-----------------|-------------|---|---|
| | | | | 1 | 2 | 3 |
| 7-1 | 37154192 | CYLINDER | 1 | | | |
| 7-2 | 37135985 | GASKET | 1 | 1 | 1 | 2 |
| 7-3 | 95053575 | CAPSCREW 1/2 X 1 1/4 | 4 | | | |
| 7-4 | 37140043 | PISTON | 1 | | 1 | 1 |
| 7-5 | 37197993 | PISTON RINGS | 1 | 1 | 1 | 2 |
| 7-6 | 95067617 | SCREW—HOLLOW HEX HEAD | 4 | | | |
| 7-7 | 32054488 | CROSSHEAD PISTON ASSY. | 1 | | | |
| 7-8 | 37170271 | ● PIN—CROSSHEAD | 1 | | | |
| 7-9 | 95065678 | SCREW—SET HOLLOW HEAD CUP POINT | 2 | | | |
| 7-10 | 32015109 | SET, RING | 1 | 1 | 1 | 2 |
| 7-11 | 37181146 | GUIDE—CROSSHEAD | 1 | | | |
| 7-12 | 30294201 | GASKET | 1 | 1 | 1 | 2 |
| 7-13 | 95053575 | CAPSCREW 1/2 X 1 1/4 | 4 | | | |
| IF RING REPLACEMENT IS DESIRED WE RECOMMEND AN ECONOMICAL RING/GASKET KIT. SEE PAGE 17. | | | | | | |

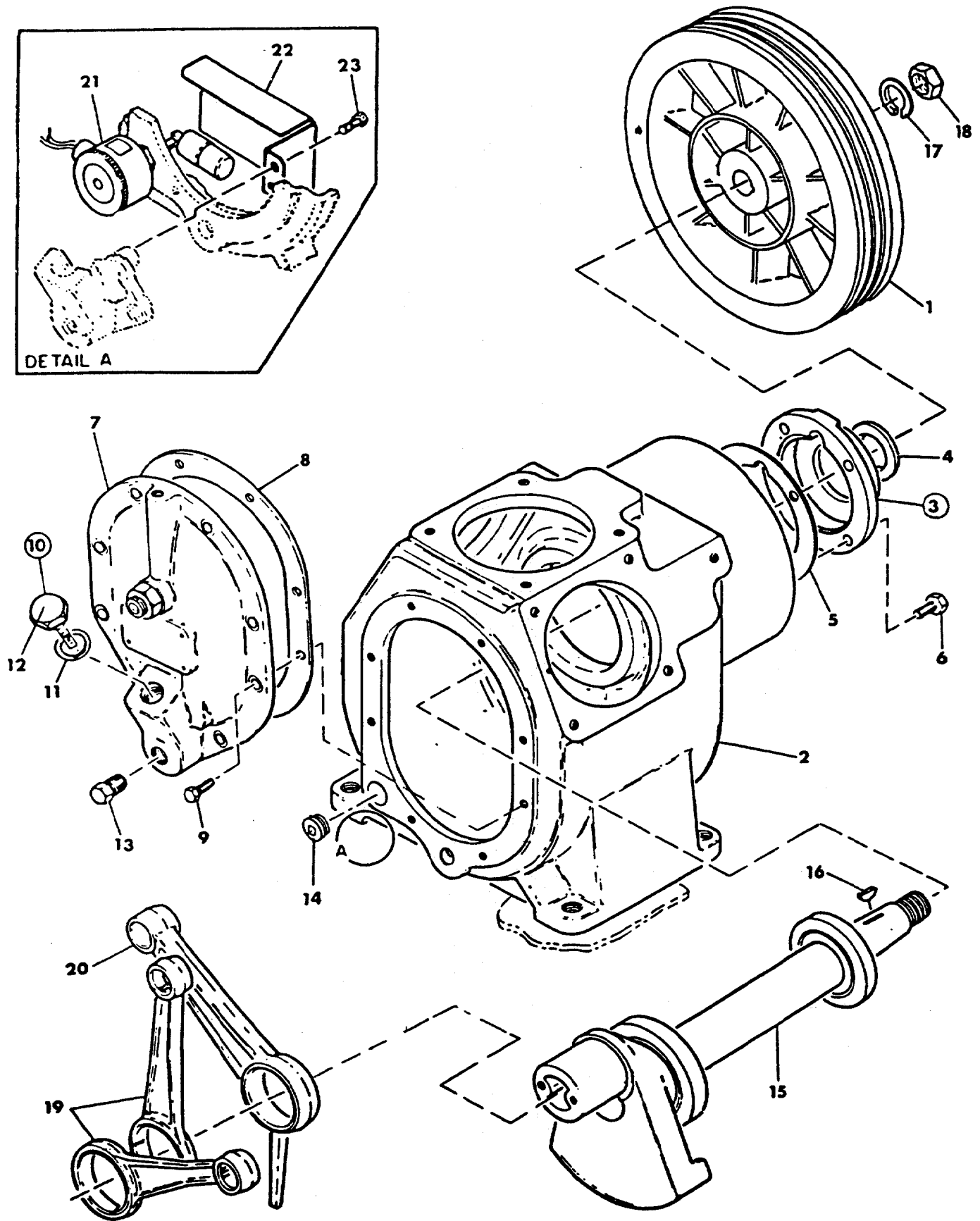
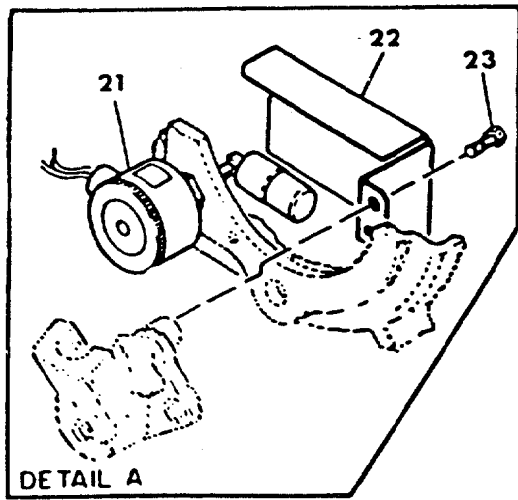

FIGURE 8. COMPRESSOR FRAME ASSEMBLY

| REF. NBR. | PART NUMBER | DESCRIPTION | UNITS PER ASSY. | REC. SPARES | | |
|-----------|-------------|---|-----------------|-------------|---|---|
| | | | | 1 | 2 | 3 |
| 8-1 | 32020323 | WHEEL—"V" BELT | 1 | | | |
| 8-2 | 32012536 | FRAME—COMPRESSOR | 1 | | | |
| 8-3 | 37004371 | COVER—SHAFT END COMPLETE | 1 | | | |
| 8-4 | 37007655 | ● SEAL—SHAFT OIL | 1 | | 1 | 2 |
| 8-5 | 30295174 | ● GASKET | 1 | 1 | 1 | 2 |
| 8-6 | 95251013 | CAPSCREW | 4 | | | |
| 8-7 | 37004306 | COVER—FRAME END COMPLETE | 1 | | | |
| 8-8 | 30439269 | ● GASKET | 1 | 1 | 1 | 2 |
| 8-9 | 95251013 | CAPSCREW | 8 | | | |
| 8-10 | 30289003 | ● GAUGE—OIL COMPLETE | 1 | | | |
| 8-11 | 95018149 | ● O-RING | 1 | 1 | 1 | 2 |
| 8-12 | 32000655 | ● DECAL—OIL GAUGE | 1 | | | |
| 8-13 | 95344651 | PLUG—PIPE HEX HEAD | 1 | | | |
| 8-14 | 32179020 | PLUG—PIPE SOCKET HEAD | 1 | | | |
| 8-15 | 32056269 | CRANKSHAFT—COMPLETE | 1 | | | |
| 8-16 | 95047437 | ● KEY—WOODRUFF | 1 | | | |
| 8-17 | 95064754 | ● WASHER—LOCK | 1 | | | |
| 8-18 | 30280671 | ● NUT—BELT WHEEL | 1 | | | |
| 8-19 | 30217202 | ROD—CONNECTING L.P. | 2 | | 1 | 1 |
| 8-20 | 30217319 | ROD—CONNECTING H.P. | 1 | | 1 | 1 |
| | | OPTIONAL EQUIPMENT — DETAIL A. | | | | |
| 8-21 | 32201527 | ● SWITCH—LOW OIL LEVEL SHUTDOWN | 1 | | | |
| 8-22 | 30290043 | ● ● BAFFLE—OIL LEVEL SWITCH | 1 | | | |
| 8-23 | 95311650 | ● ● CAPSCREW 1/4 X 1/2 | 2 | | | |
| | | IF BEARING AND CONNECTING ROD REPLACEMENT IS DESIRED, WE RECOMMEND A BEARING/CONNECTING ROD KIT. SEE PAGE 17. | | | | |

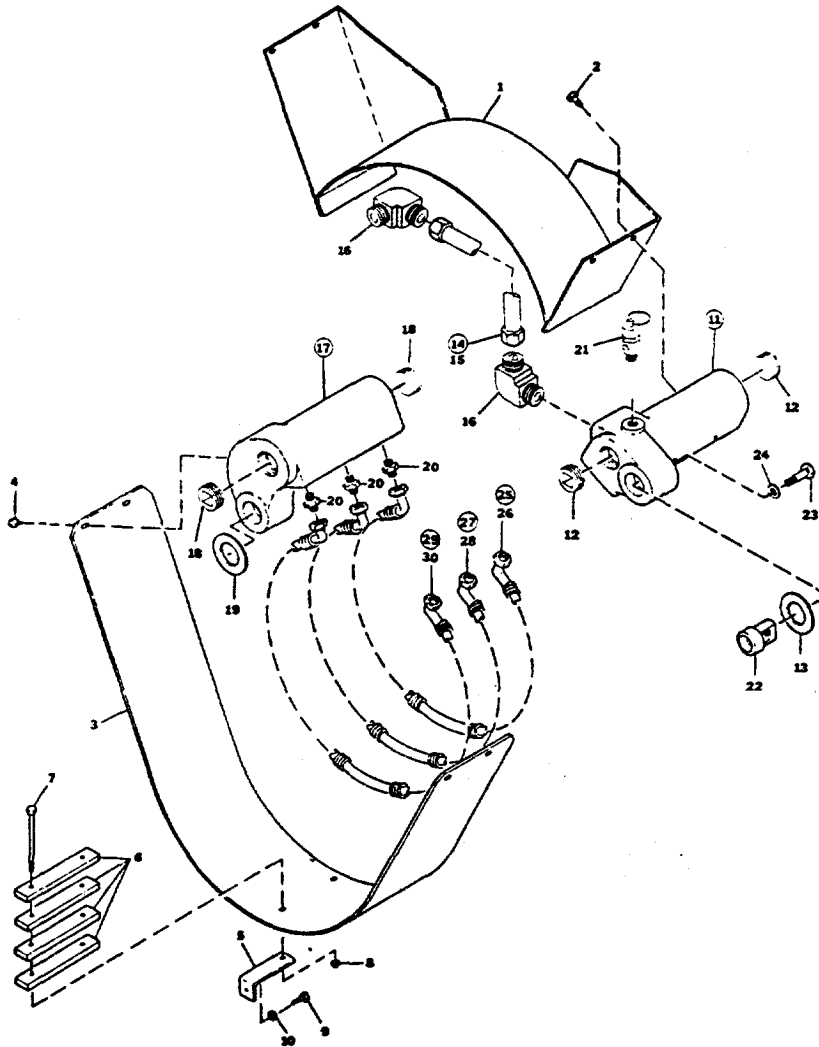

FIGURE 9. AIR INTERCOOLER ASSEMBLY

| REF. NBR. | PART NUMBER | DESCRIPTION | UNITS PER ASSY. | REC. SPARES | | |
|-----------|-------------|-----------------------------|-----------------|-------------|---|---|
| | | | | 1 | 2 | 3 |
| 9-1 | 37140027 | SHROUD—TOP | 1 | | | |
| 9-2 | 32175572 | CAPSCREW 1/4 X 1/2 | 4 | | | |
| 9-3 | 32019986 | SHROUD | 1 | | | |
| 9-4 | 32175572 | CAPSCREW 1/4 X 1/2 | 4 | | | |
| 9-5 | 37140183 | BRACE | 1 | | | |
| 9-6 | 37140175 | CLAMP | 4 | | | |
| 9-7 | 95053484 | SCREW 1/4 X 4 | 2 | | | |
| 9-8 | 95077483 | NUT—ELASTIC STOP 1/4 | 2 | | | |
| 9-9 | 95079711 | CAPSCREW 3/8 X 5/8 | 1 | | | |
| 9-10 | 95081857 | WASHER—LOCK 3/8 | 1 | | | |
| 9-11 | 37143419 | HEADER—L.P. | 1 | | | |
| 9-12 | 95033338 | ● PLUG—PIPE COUNTER—SUNK 1¼ | 2 | | | |
| 9-13 | 30294821 | ● GASKET | 1 | 1 | 1 | 2 |
| 9-14 | 32059495 | TUBE ASM—WITH NUTS | 1 | | | |
| 9-15 | 32039422 | ● NUT—TUBE | 2 | | | |
| 9-16 | 95229183 | ELBOW—TUBE | 2 | | | |
| 9-17 | 37139995 | HEADER—H.P. | 1 | | | |
| 9-18 | 95033338 | ● PLUG—PIPE COUNTER—SUNK 1¼ | 2 | | | |
| 9-19 | 30294821 | ● GASKET | 1 | 1 | 1 | 2 |
| 9-20 | 95083184 | CONNECTOR—TUBE | 22 | | | |
| 9-21 | 72062151 | VALVE—SAFETY | 1 | | | 1 |
| 9-22 | 30221113 | CONNECTION—MANIFOLD | 2 | | | |
| 9-23 | 95052924 | CAPSCREW 1/2 X 1½ | 2 | | | |
| 9-24 | 30345235 | WASHER—STEEL | 2 | | | |
| 3-25 | 37140076 | TUBE—FINNED ASM—WITH NUTS | 4 | | 1 | 2 |
| 9-26 | 95227260 | ● NUT—TUBE | 8 | | | |
| 9-27 | 37140084 | TUBE—FINNED ASM—WITH NUTS | 3 | | 1 | 2 |
| 9-28 | 95227260 | ● NUT—TUBE | 6 | | | |
| 9-29 | 37140092 | TUBE—FINNED ASM—WITH NUTS | 4 | | 1 | 2 |
| 9-30 | 95227260 | ● NUT—TUBE | 8 | | | |

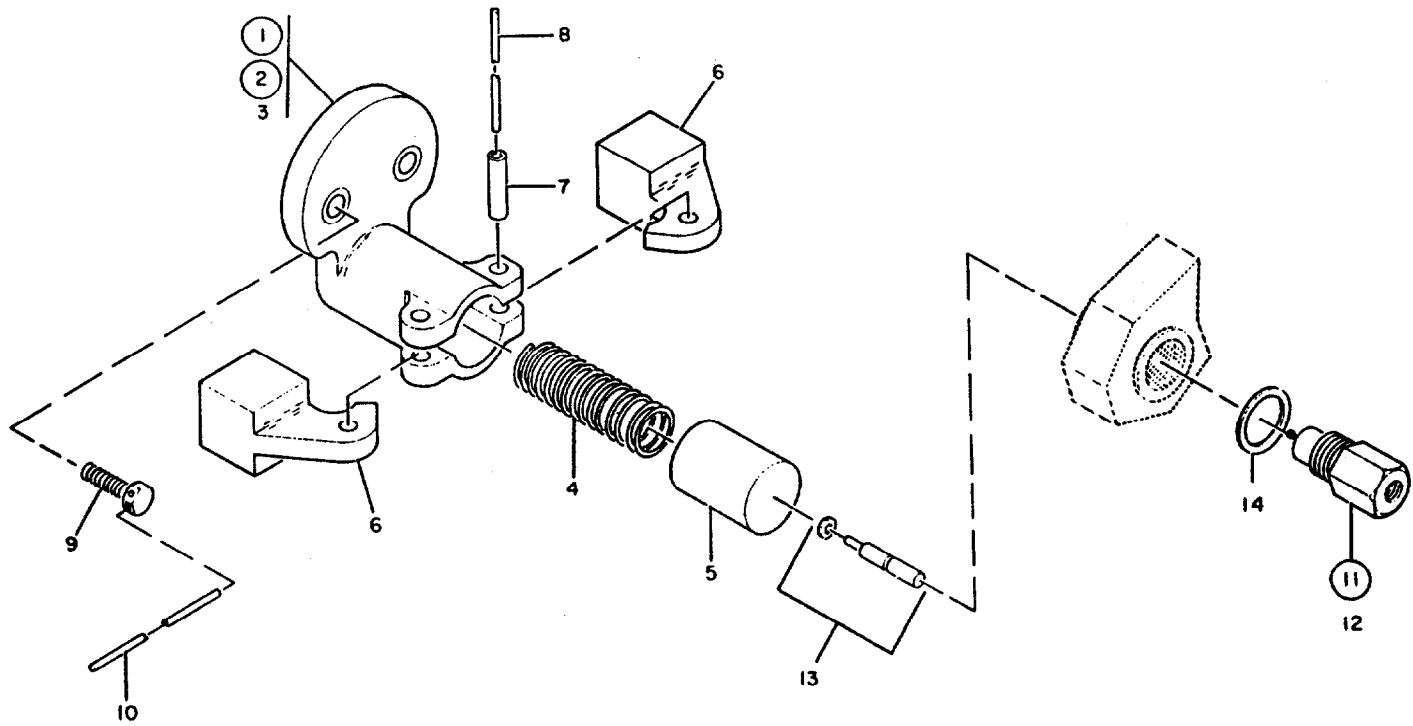
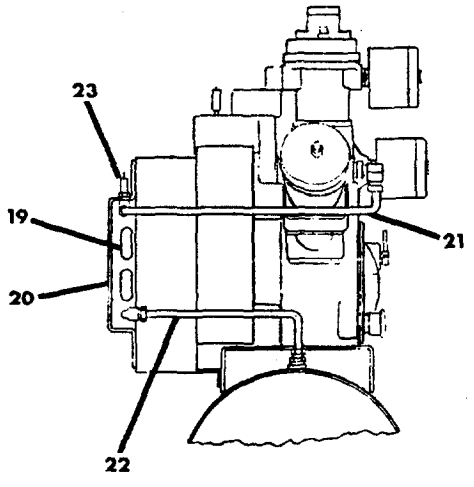
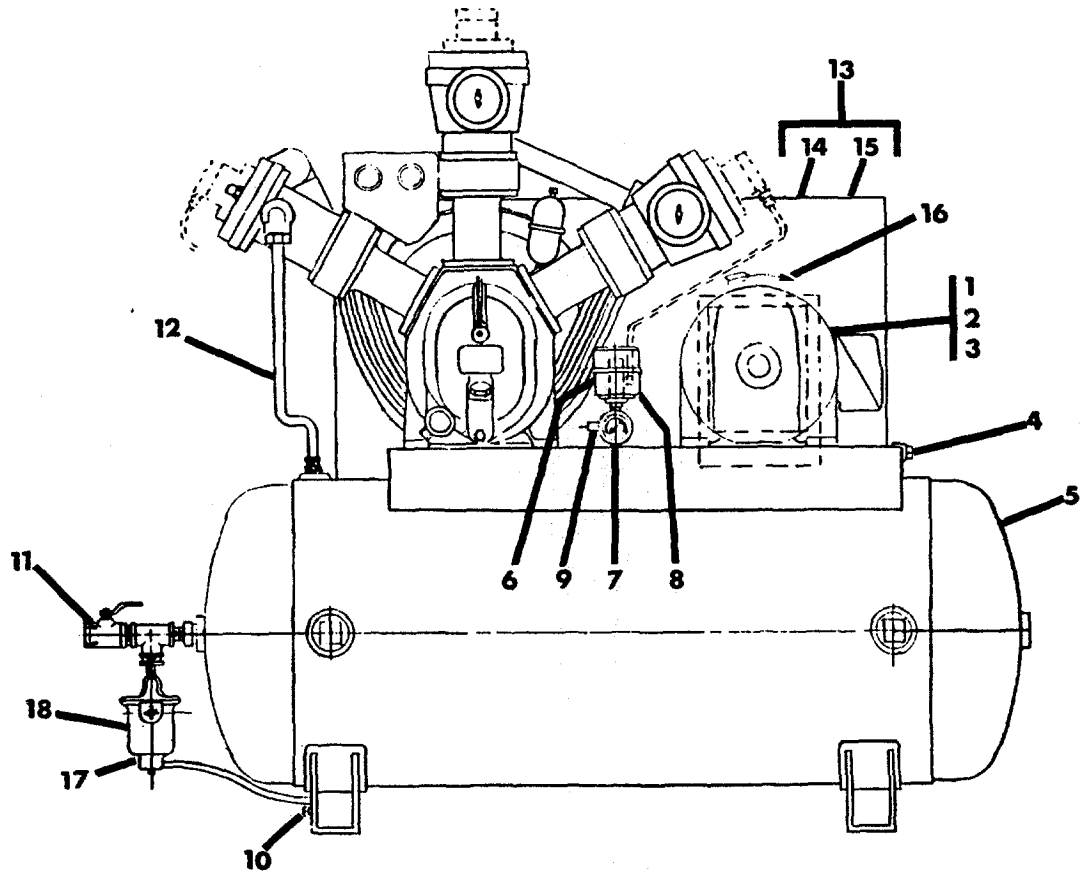
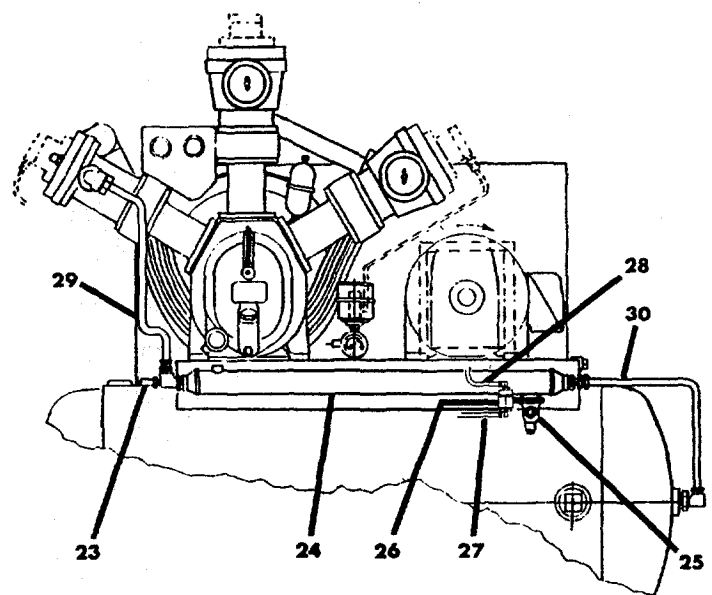

FIGURE 10. CENTRIFUGAL UNLOADER AND PILOT VALVE ASSEMBLIES

| REF. NBR. | PART NUMBER | DESCRIPTION | UNITS PER ASSY. | REC. SPARES | | |
|-----------|-------------|----------------------------|-----------------|-------------|---|---|
| | | | | 1 | 2 | 3 |
| 10-1 | 37129681 | UNLOADER—CENTRIFUGAL | 1 | | | |
| 10-2 | 30290944 | ● CAP ASSEMBLY—CRANKPIN | 1 | | | |
| 10-3 | 30287767 | ●● CAP—CRANKPIN | 1 | | | |
| 10-4 | 30815898 | ●● SPRING | 1 | | | 1 |
| 10-5 | 30285688 | ●● PLUNGER | 1 | | | |
| 10-6 | 30220875 | ●● WEIGHT | 2 | | | |
| 10-7 | 30214951 | ●● PIN | 2 | | | |
| 10-8 | 90799271 | ●● LOCKWIRE | 1 | | | |
| 10-9 | 95101929 | CAPSCREW | 2 | | | |
| 10-10 | 90799289 | LOCKWIRE | 1 | | | |
| 10-11 | 37046869 | ● VALVE ASM—PILOT—COMPLETE | 1 | | 1 | 1 |
| 10-12 | 37113701 | ●● VALVE ASSEMBLY | 1 | | | |
| 10-13 | 32028706 | ●● PIN ASSEMBLY, THRUST | 1 | 1 | 1 | 2 |
| 10-14 | 30346597 | WASHER—COPPER | 1 | | | |



**DETAIL A - AIR COOLED
AFTERCOOLER**



DETAIL B - WATER COOLED AFTERCOOLER

FIGURE 11. COMPRESSOR DRIVE, AIR RECEIVER, AND ACCESSORIES.

| REF. NBR. | PART NUMBER | DESCRIPTION | UNITS PER ASSY. | REC. SPARES | | |
|-----------|-------------|---|-----------------|-------------|---|---|
| | | | | 1 | 2 | 3 |
| 11-1 | | MOTOR † | 1 | | | |
| 11-2 | | PULLEY, MOTOR † | 1 | | | |
| 11-3 | | BELT, V † | 3 | | 3 | 3 |
| 11-4 | 32188690 | TIGHTENER, BELT—COMPLETE—10 H.P. STD. | 1 | | | |
| 11-4 | 32188708 | TIGHTENER, BELT—COMPLETE—15 H.P. STD. | 1 | | | |
| 11-5 | 32162406 | RECEIVER ASSEMBLY 120 GAL. HORIZONTAL | 1 | | | |
| 11-6 | 32169997 | VALVE, AUXILIARY CONSTANT SPEED | 1 | | | 1 |
| 11-6 | 32151722 | VALVE, AUXILIARY DUAL CONTROL | 1 | | | 1 |
| 11-7 | 32013872 | GAUGE, PRESSURE | 1 | 1 | 1 | 1 |
| 11-8 | 37005907 | SWITCH, PRESSURE—STANDARD | 1 | 1 | 1 | 1 |
| 11-9 | 72061971 | VALVE, SAFETY—RECEIVER | 1 | | 1 | 1 |
| 11-10 | 32027120 | VALVE, DRAIN—MANUAL | 1 | | | |
| 11-11 | 32180242 | VALVE, BALL—SERVICE | 1 | | | |
| 11-12 | 32117970 | TUBE ASSEMBLY—COMPRESSOR/RECEIVER | 1 | | | |
| 11-13 | 32002594 | BELT GUARD—COMPLETE | 1 | | | |
| 11-14 | 32003378 | ● BACK, BELT GUARD | 1 | | | |
| 11-15 | 37154812 | ● COVER, BELT GUARD | 1 | | | |
| 11-16 | 30286686 | DECAL, ROTATION ARROW | 1 | | | |
| | | OPTIONAL EQUIPMENT | | | | |
| 11-17 | 32005282 | TRAP, AUTO DRAIN | 1 | | | |
| 11-18 | 32180200 | VALVE, BALL—1/4 | 1 | | | 1 |
| | | DETAIL A | | | | |
| 11-19 | 32003220 | COIL, AFTERCOOLER | 1 | | | 1 |
| 11-20 | 32003246 | COVER, AIRCOOLED AFTERCOOLER | 1 | | | |
| 11-21 | 32118069 | TUBE ASSEMBLY, COMPRESSOR/ACAC. | 1 | | | |
| 11-22 | 32118077 | TUBE ASSEMBLY, ACAC/RECEIVER | 1 | | | |
| 11-23 | 31385693 | VALVE, SAFETY—DISCHARGE | 1 | | 1 | 1 |
| | | DETAIL B | | | | |
| 11-24 | 32144412 | AFTERCOOLER, WATER COOLED | 1 | | | |
| 11-25 | 35229723 | VALVE, WATER | 1 | | | |
| 11-26 | 30220651 | VALVE, REVERSING | 1 | | | |
| 11-27 | 32146581 | TUBE ASSEMBLY, REV. VALVE/HEAD | 1 | | | |
| 11-28 | 32146599 | TUBE ASSEMBLY, REV. VALVE/INTRCL. | 1 | | | |
| 11-29 | 32146565 | TUBE ASSEMBLY, COMPR./WCAC | 1 | | | |
| 11-30 | 32146433 | TUBE ASSEMBLY, WCAC/RECVR. | 1 | | | |
| | | † SPECIFY DISCHARGE PRESSURE OF COMPRESSOR AND COMPLETE MOTOR NAMEPLATE DATA. | | | | |

STEP SAVER KIT

For your convenience, the following parts and/or spare parts for your compressor are available in parts kits. When ordering the kits below, use kit names as Description and the Part No. as shown.

| PART NO. | DESCRIPTION |
|----------|-----------------------------|
| 32127482 | KIT, FILTER |
| 32132953 | KIT, VALVE/GASKET |
| 32132961 | KIT, RING/GASKET |
| 32132979 | KIT, BEARING/CONNECTING ROD |
| 37126729 | KIT, GASKET |

NOTICE

THE USE OF REPAIR PARTS OTHER THAN THOSE INCLUDED WITHIN THE INGERSOLL-RAND COMPANY APPROVED PARTS LIST MAY CREATE UNSAFE CONDITIONS OR MECHANICAL FAILURES OVER WHICH THE INGERSOLL-RAND COMPANY HAS NO CONTROL. THEREFORE, INGERSOLL-RAND COMPANY CAN BEAR NO RESPONSIBILITY FOR EQUIPMENT IN WHICH NON-APPROVED REPAIR PARTS ARE INSTALLED.

The manufacturer reserves the right to make changes or add improvements without notice and without incurring any obligation to make such changes or add such improvements to products sold previously.

GLOSSARY

GROUP ASSEMBLY PARTS LIST

Parts are listed in disassembly sequence, where applicable. The relationship of an article to its next higher assembly is indicated by indenture. For example, in the description column;

Assemblies and Detail Parts

- . Attaching Parts for Assemblies and Detail Parts
- .. Subassemblies
- ... Attaching Parts of Subassemblies
- ... Detail Parts for Subassemblies, etc.

ITEM COLUMN

The item number is the number assigned to the part in the listing. This item number identifies the part on the associated illustration.

PART NUMBER COLUMN

All numbers shown are Ingersoll-Rand part numbers which must be specified when ordering replacement parts. The letters NSS indicates that the part is "Not Sold Separately" with certain models. The letter NA indicates that the part is "Not Applicable" to certain models.

DESCRIPTION COLUMN

The description column contains the standard item name with modifiers. The relationship of an article to its next higher assembly is shown in this column by indenture.

QTY PER ASSEMBLY COLUMN

The quantities specified in this column are the number of parts used per one next higher assembly and are not necessarily the total number of parts used in the overall model. The letters NA indicate that the part is "Not Applicable" to certain models.

HOW TO SELECT RECOMMENDED SPARES

This catalog contains a listing of the parts which are included in each of the following classes of recommended spares.

CLASS I — **MINIMUM**—Suggested for Domestic Service where interruptions in service are not important.

CLASS II — **AVERAGE**— Suggested for Domestic Service where some interruptions in continuity of service are not objectionable.

CLASS III — **MAXIMUM**—Suggested for Export or for Domestic Service where interruption in service are objectionable.

When ordering recommended spares or step-saver kit, please follow the procedure as outlined for compressor parts.

ORDERING INSTRUCTIONS

Refer all communications to the nearest Ingersoll-Rand Service Distributor

HOW TO ORDER COMPRESSOR PARTS

When ordering replacement parts, please specify:

1. The **MODEL** and **SERIAL NUMBER** as stamped on Compressor Nameplate.
2. The **FORM NUMBER** of this booklet.
3. The **QUANTITY, DESCRIPTION & PART NUMBER** exactly as listed.

EXAMPLE

Send the following parts for a Model _____

Serial No. _____

Literature Form Number _____

| | |
|--------------------|------------|
| 1 Switch, Pressure | (32147738) |
| 1 Element-Filter | (97021745) |
| 1 Gauge, Pressure | (32013872) |

LOOK WHAT INGERSOLL-RAND CAN DO FOR YOU

Ingersoll-Rand Company
Small Compressor Division
Campbellsville, Ky. 42718



SPECIAL ENGINEERING SERVICE

We can help you with your compressed air problems by surveying your needs and recommending the proper compressor and air piping system for maximum efficiency.



EFFICIENT FIELD SERVICE

We maintain a staff of trained mechanics to provide you with preventive maintenance or meet any emergencies you may have.



SPARE PARTS

We stock genuine I-R spare parts for your I-R equipment, avoiding possible costly delays or the substitution by inferior parts. As a result, old machines are kept in good-as-new condition.



COMPLETE REPAIR SERVICE

Trained mechanics will repair or overhaul compressors by factory recommended methods, using only genuine I-R parts.



COMPLETE STOCK OF EQUIPMENT

Our stock of complete machines which can usually take care of any need, is backed up by Ingersoll-Rand prompt factory shipment to assure you on-time delivery.

A SUBSTITUTE IS NOT A REPLACEMENT.

You can protect your compressor by insisting on genuine Ingersoll-Rand replacement parts and maintenance kits. Not only are they made with precise dimensions, and OEM-specified metallurgy, but each one is backed by our warranty. Ask your Air Center, distributor, or direct Ingersoll-Rand salesperson for an "It's Real Ingersoll-Rand" sticker to mark your unit, and be sure that your machines are equipped with only the best - genuine Ingersoll-Rand replacement parts.

DISTRIBUTED BY:



SAFETY PRECAUTIONS

DO NOT DESTROY

This manual contains important safety information, and should be made available to all personnel who operate and/or maintain this product. Carefully read this manual before attempting to operate or perform maintenance on this compressor.

**INSTRUCTION
MANUAL**

MODELS

5T2NL & 10T3NL

Concentric Ring Valve

Air Compressors

With Non-lubricated Cylinder

for Oil-Free Air

 **INGERSOLL-RAND®**

T30

REFER ALL COMMUNICATIONS TO THE NEAREST
INGERSOLL-RAND FULL SERVICE DISTRIBUTOR.

Form SCD-421
May 1988

⚠ WARNING

STATEMENT CONCERNING THE USE OF THIS EQUIPMENT FOR BREATHING AIR AND/OR AQUA LUNG SERVICE.

If the model number on this air compressor contains the letters "BAP", the air compressor is suitable for breathing air services. Compressors that DO NOT bear this designation are NOT capable of producing air of breathing quality. For use in breathing air applications, an air compressor must be fitted with additional specialized equipment to properly filter and/or purify the air to meet all applicable federal, state and local laws, rules, regulations and codes, such as, but not limited to, OSHA 29 CFR 1910.34. Compressed Gas Association Commodity Specifications G-7.1-1966. Grade D Breathing Air, and/or Canadian Standards Association. Should the Purchaser and/or User fail to add such specialized equipment, and proceed to use the air compressor for breathing air service, the Purchaser/User assumes all liability resulting therefrom without any responsibility or liability being assumed by Ingersoll-Rand Company.

The purchaser is urged to include the above provisions in any agreement for any resale of this air compressor.



Hazardous Vapors. Can cause severe nausea, fainting or death.
Compressed air from this air compressor may contain poisonous carbon monoxide.
Certain sprayed material such as paints, insecticides, weed killer, sand, etc., may be harmful if inhaled or used in a closed area.

Never directly inhale the compressed air produced by this air compressor.

Always read labels with containers when spraying paints or poisons.

Always use the air compressor in a well-ventilated area.

Use a respirator or mask whenever there is a chance that you might inhale any sprayed material. If a mask is used, read all instructions provided with the mask to ensure it will protect you from the materials you are spraying.



Hazardous Voltage. Can cause severe injury or death.

Always disconnect power supply before performing any maintenance or repair work.

Always connect power supply to a properly grounded electrical circuit with the specified voltage and fuse protection.

Never operate compressor in rain, a wet area, or near an explosive environment.



Flammable vapors. Can cause a fire or explosion, and result in severe injury or death.

Sparks from the motor's electrical contacts can ignite flammable vapors from gasoline, natural gas or solvents.

Do not operate the air compressor in any areas where explosive or flammable vapors or liquids may exist.



Compressed air has great force.

Over-pressurizing the air receiver, or using a receiver which does not meet the design limits for this compressor, can cause the air receiver to rupture or explode, and result in severe injury or death.

Changes to the air receiver structure will cause the air receiver to weaken and can cause the air receiver to rupture or explode, and result in severe injury or death.

Internal rusting in the air receiver will cause the air receiver to weaken and can cause the air receiver to rupture or explode, and result in severe injury or death.

Air pressure beyond design limits can cause the air receiver to rupture or explode, and result in severe injury or death.
Improper use of air tools or air attachments can cause explosion, and result in severe injury or death.

The air receiver is equipped with a relief valve to protect against over-pressurization. **DO NOT REMOVE, ADJUST OR MAKE SUBSTITUTIONS FOR THE RELIEF VALVE.** Periodically pull the ring on the relief valve to ensure it operates freely. If the valve is stuck or does not operate freely, it must be replaced.

Never drill into, weld to, or alter the air receiver in any manner.

Drain water/condensate from the air receiver daily or before each use.

Pressure switch and unloader valve operation is related to motor/engine horsepower, air receiver rating, and relief valve setting. **DO NOT ATTEMPT TO ADJUST, REMOVE OR BYPASS THE PRESSURE SWITCH, OR CHANGE OR MODIFY ANY PRESSURE CONTROL RELATED DEVICE.**

Do not use any air tools or air attachments without first determining the maximum air pressure recommended for that particular air tool or air attachment.



Compressed air. Can propel dirt, sand, metal shavings, etc., and result in severe injury.

Never point air nozzle or sprayer toward any part of the body, or another person.

Always wear safety glasses or goggles when servicing the compressor.



Moving Parts. Can cause severe injury.

Compressors equipped with electric motors are designed to cycle automatically when the power is ON. Automatic cycling during service or repair can cause severe injury.

Always disconnect the power supply on electric motor models before performing any maintenance or repair work on the compressor.

Always disconnect the power supply on electric motor models if the compressor is to be left unattended.

Always ensure pressure is released from the compressor, air receiver, and all attachments before performing any maintenance or repair.

Never operate the compressor with the beltguard assembly removed, damaged or broken.



Hot Parts. Compressors get hot while running, and can cause severe burn if touched.

Never touch the compressor, motor/engine, or tubing during or shortly after compressor operation.

WARNING: THE EXPORT OR RE-EXPORT OF THIS DRAWING OR A PRODUCT PRODUCED BY THIS DRAWING IS SUBJECT TO U.S. EXPORT ADMINISTRATION REGULATIONS AND OTHER APPLICABLE GOVERNMENTAL RESTRICTIONS OR REGULATIONS.

INDEX

| | |
|---|--------|
| SECTION I | |
| GENERAL DESCRIPTION | 4 |
| Application | 5 |
| SECTION II | |
| INSTALLATION AND START-UP | |
| RECOMMENDATIONS | 5-9 |
| Location and Foundation | 6 |
| Inlet Piping | 6 |
| Electrical | 6-7 |
| Wiring | 7 |
| Fuses | 7 |
| Magnetic Starter | 7 |
| Typical Wiring Diagrams | 28-29 |
| Compressor Startup | 7 |
| Pressure Regulation | 7 |
| Low Oil Level Switch | 8 |
| Discharge Piping | 8-9 |
| Complete Warranty Registration | 9 |
| SECTION III | |
| REGULATION | 9-11 |
| Automatic Start and Stop Control | 9 |
| Pressure Switch Adjustment | 9 |
| Constant Speed Control | 10 |
| Dual Control | 10 |
| Auxiliary Valve Adjustment | 10 |
| SECTION IV | |
| OPERATION | 11-16 |
| Operating Checks | 11 |
| Compressor Lubrication | 11 |
| Frame Oil Change | 11 |
| Lubricating Oil Recommendations | 11-12 |
| Motor Lubrication and Care | 12 |
| Sleeve Bearing Motors | 12 |
| Sleeve Bearing Motors | 12 |
| Ball Bearing Motor with Grease Fittings | 12 |
| Air Inlet Filter/Silencer | 12 |
| Breather Trap | 12 |
| Intercooler | 12 |
| SECTION V | |
| Safety Valve | 13 |
| Operation of Starting Unloading System | 13 |
| Pilot Valve Adjustment | 14 |
| Cylinder Relief Valve | 14 |
| Distance Piece Pressure System | 14 |
| Compressor Identification Chart | 16 |
| SECTION V | |
| TROUBLE GUIDE | 17 |
| SECTION VI | |
| MAINTENANCE | 18-21 |
| ROUTINE INSPECTION AND SERVICE | 18 |
| General | 20 |
| Torque Values | 20 |
| Air Valve Cleaning | 20 |
| Belt Installation and Adjustment | 21 |
| Standard Belts | 21 |
| SECTION VII | |
| OPTIONAL EQUIPMENT | |
| ACCESSORIES AND PIPING ARRANGEMENT | 22-29 |
| Aftercoolers | 22 |
| Air-Cooled Aftercoolers | 22 |
| Water-Cooled Aftercoolers | 22 |
| Automatic Water Valve | 22 |
| Automatic Drain Trap | 23 |
| Priming | 24 |
| Air Receiver | 24 |
| SECTION VIII | |
| PARTS LIST | 24-27 |
| Model 5T2NL | 24-25 |
| Model 10T3NL | 26-27 |
| Step Saver Kits | 25, 27 |
| SECTION IX | |
| TYPICAL WIRING DIAGRAMS | 28-29 |

SECTION I

GENERAL DESCRIPTION

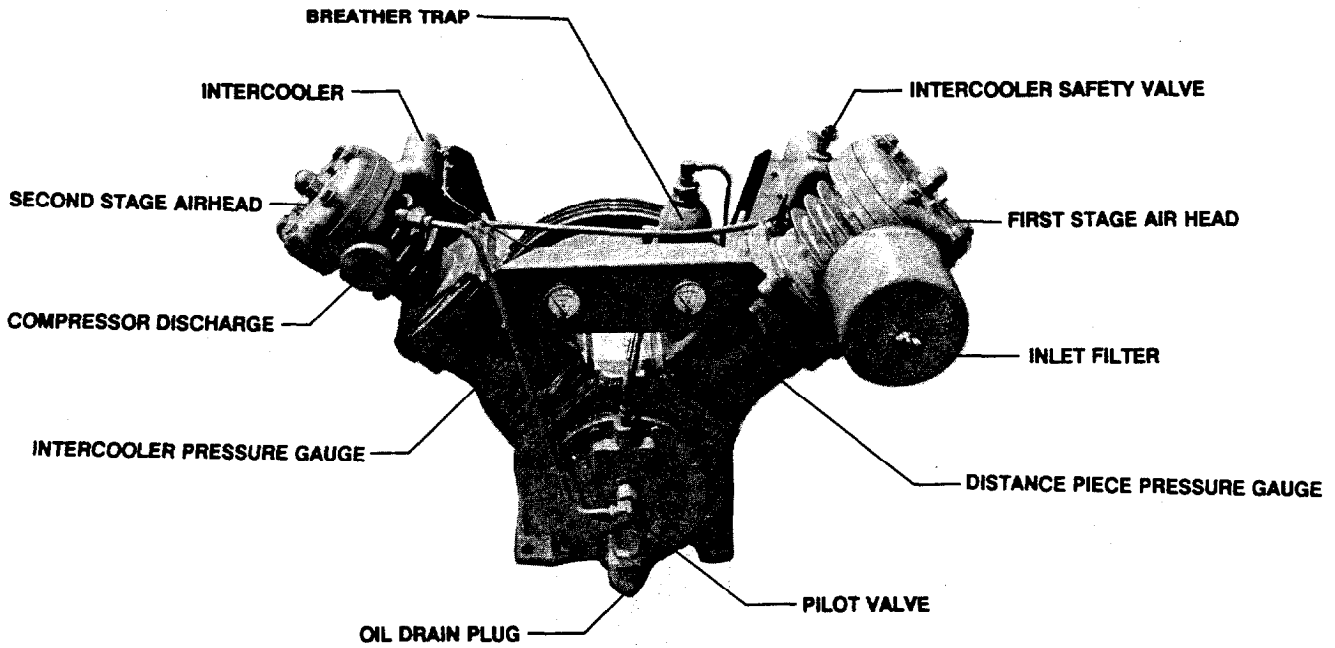

Figure 1-1. Model 5T2NL Two-stage, two cylinder compressor.

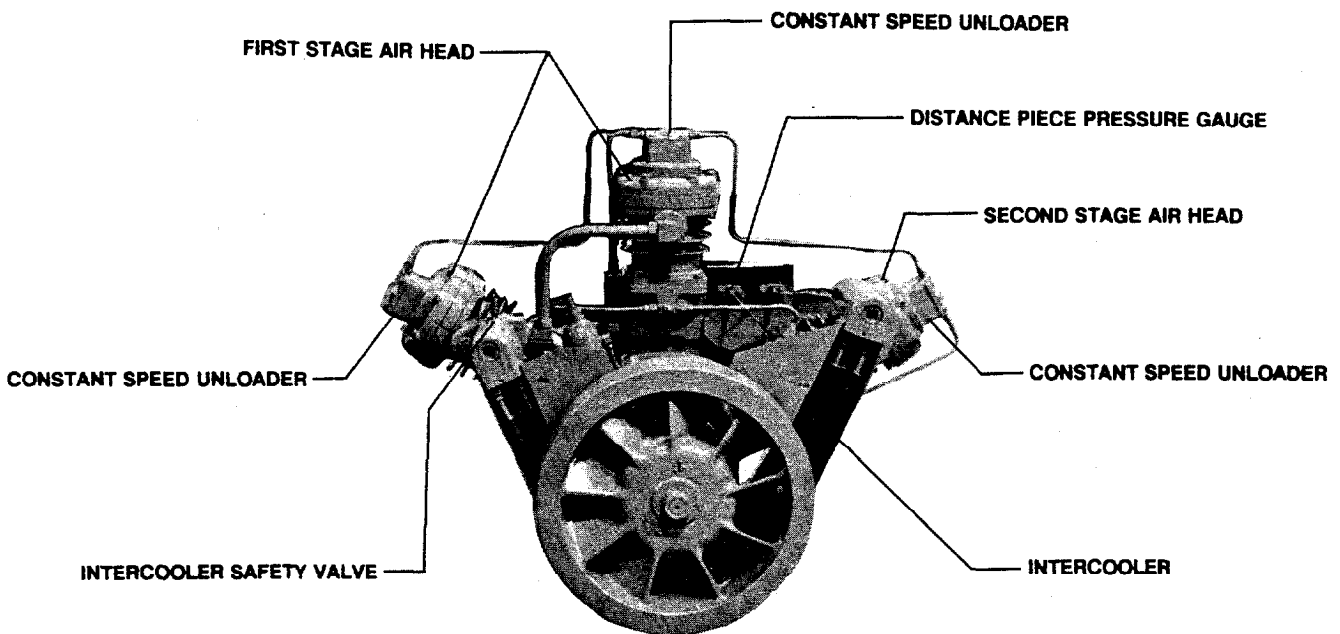

Figure 1-2. Model 10T3NL Two-stage, three cylinder compressor.

APPLICATION

Ingersoll-Rand's 5 through 15 H.P. Non-Lubricated units are two stage, single-acting, compressors that do not require installation on a special foundation. All models can be furnished as compact, self-contained, receiver-mounted units, automatically regulated and driven by an electric motor. A water-cooled or air-cooled aftercooler along with an automatic condensate drain valve can be furnished as optional equipment. The units are also sold as bare, baseplate, or duplex mounted compressors.

These compressors may be used for any compressed air application requiring air from 50 to 125 psi. (3.52 to 8.79 kg/cm²) with piston displacement from 26.4 to 67.1 (.735 to 1.9M³/Min.)

Application of these compressors is common as either a primary or supplementary source of air for instrument control and any application where oil in the discharge air might prove detrimental to the process involved or the food being processed. Many applications are found not only in hospitals and laboratories, but also in the chemical, food, packaging, brewing, and also in the distilling industries.

Moderate compressor speeds along with time proven, efficient concentric ring valves, solid-end connecting rods and positive-acting starting unloading provide long-life dependability. Also, simplified design permits rapid access to any part of the unit for inspection or replacement of parts.

PRINCIPLE OF OPERATION

The design of the Models 5T2NL and 10T3NL Compressor differs from conventional units primarily in the pistons and rings. Reference to the illustration shown in Figure 1-1 & Figure 1-2 will aid in clarifying the principle of operation, and will assist the reader in locating the various compressor assemblies.

Air enters the cylinders through the inlet filter silencer and inlet valve. On the compression stroke, the air is compressed from its original volume to a smaller volume, or higher pressure, and is then pushed out of the cylinder through the discharge valve and into the intercooler tubes, where the heat of first-stage compression is removed by the action of the fan passing cool air over the intercooler tubes. On the suction stroke of the second-stage piston this cooled air enters the second-stage cylinder through the inlet valve. The compression stroke of the second-stage piston compresses the air to the final discharge pressure and forces it out through the discharge valve into the receiver or system.

To prevent oil or oil vapor from migrating into the compressed air, the distance piece above the cross head is pressurized. The lower end of the elongated piston is splash lubricated and contains two compression rings for stabilizing distance piece pressure, a scrapper ring with vent holes, and an oil control ring in a groove with drain holes.

The piston forms the support for the piston ring and does not touch the cylinder wall, the necessary guiding and support coming from the cross head. The compression rings and the oil control ring and scrapper ring are spaced to prevent overlap in their travel, thus leaving a safe margin between the dry and oiled sections of the assembly.

As an added precaution against oil contamination of the air, a positive reduced first stage oil suppressing air pressure is applied to the intermediate volume between the compression and cross-head rings through an orifice in the first-stage piston. As an extra precaution, the Model 10T3NL incorporates an injected distance piece pressure from the air receiver. This regulator controlled pressure insures a constant 25 (1.75 kg/cm²) to 30 (2.11 kg/cm²) PSIG distance piece pressure during compressor operation.

This pressure is piped across to all cylinders and is absolutely vital for the satisfactory operation of the Models 5T2NL and 10T3NL compressors.

The Model 5T2NL and 10T3NL, if regulated by Constant Speed Control or Dual Control, has special provisions made for maintaining this oil suppressing air pressure whenever the compressor operates in the unload cycle. The auxiliary valve supplies air pressure through the constant speed unloaders, orifice, and check valve when the compressor is in the unload cycle. When operating in the load cycle a reduced air pressure is received from a small hole in the low pressure piston. For Auto Start and Stop Control models, this provision is the same as operating in the load cycle.

This Model 10T3NL incorporates the above system but uses the air receiver pressure injected by means of an air pressure regulator and UL-100 valve to insure a stable distance piece pressure of 25-30 PSIG during both the load and unload cycle.

Starting unloading is accomplished through the action of the centrifugal unloader and pilot valve by relieving the air pressure from inside the compressor upon stopping.

The operation of the Duplex Model is basically the same as the air receiver model, except with the duplex model two compressors are used on one air receiver instead of one compressor.

SECTION II

INSTALLATION AND START-UP RECOMMENDATIONS

Step 1.

Unload the compressor from delivering vehicle — the purchaser must arrange for adequate lifting equipment at the job site.

IMPORTANT NOTE: The purchaser assumes title to the compressor equipment at the manufacturers shipping dock. Immediately upon receipt of the equipment, it should be inspected for any damage that may have occurred during shipment. If damage is present, demand an inspection immediately by an inspector from the carrier. Ask him how to file a claim for damages.

Step 2.

Check compressor nameplate to be sure the unit is the model and size ordered. Do this before uncrating. Check Receiver Nameplate to be sure the tank is adequate for pressure at which you intend to operate.

Step 3.

Check motor nameplate to be sure motor is suitable for your electrical conditions (Volts-Phase-Hertz).

IMPORTANT NOTE: Do Not Use Triple Voltage 3 Phase Motor For 200-208 Voltage 3 Phase Application. Must Use 200 Volt Motor Only.

Step 4. LOCATION & FOUNDATION

NOTE: Ideal ambient temperature is (70°F) (21°C).

In cold climates, it is desirable to install the compressor within a heated building. Choose a clean, relatively cool location, and provide ample space around the unit for cooling and general accessibility. Place the beltwheel side toward the wall, leaving at least 15" (380mm) for air circulation to the beltwheel fan. The location should also be near a source of water and a drain line to simplify piping connections if a water-cooled aftercooler is to be used. (Note: If a detached receiver is to be used, consider placing the receiver outdoors to provide more effective heat dissipation, keeping in mind that condensed water in the receiver may freeze).

Provide adequate fresh air and exhaust ventilation from area in which the compressor is located. Provide 1,000 cu. ft. fresh air per minute per 5 horsepower. Ventilation by gravity or mechanical means is approved.

INLET PIPING — If the air in the vicinity of the compressor is unduly dirty or contains corrosive fumes, we recommend piping the air filter to a source of cleaner air or use a special heavy duty filter. If it is found necessary to install inlet piping, make the line as short and direct as possible and as large, or larger than the diameter of the inlet connection at the compressor. The inlet piping must increase in diameter for every 50' (15.25 m) of length. If the total length is between 50' (15.25 m) and 100' (30.5 m), increase the pipe diameter at the mid-point in the length, i.e., if the total length is 80' (24.4 m), increase the pipe diameter at the 40' (12.2 m) point. Attach the air cleaner to the end of the inlet air line, and if the inlet is piped outdoors, it should be hooded to prevent the entrance of rain or snow. See Figure 2-1. Fine airborne dust, such as cement and rock dust, require special filtration equipment not furnished as standard equipment on this compressor. Such filtration equipment is available from your local Ingersoll-Rand Distributor.

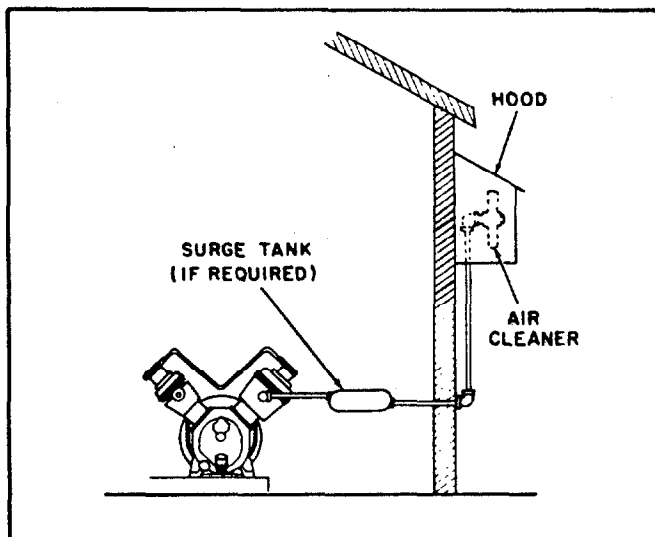

Figure 2-1. Inlet piping arrangement.

NOTE: If the compressor is to be run with Constant Speed Regulation. (See Section III, Regulation), and the air inlet is to be piped away, a small surge tank should be installed in the inlet piping next to the compressor. See Figure 2-1. If a surge tank is not installed, the air that surges in and out of the inlet when the compressor is running unloaded, will cause the inlet piping to heat up. When the compressor loads, the hot piping would increase the temperature of the inlet air to a point that would contribute to carbonization and consequent valve trouble. The capacity of the surge tank should be 4 gal. (15.1 liters) minimum.

A well ventilated location should be selected for this machine when operating in very damp climates or under conditions of high humidity. These atmospheric conditions are conducive to the formation of water in the frame, and if adequate operation and ventilation are not provided, rusting, oil sludging and rapid wear of running parts will result. This is particularly true when operating on very intermittent duty applications.

The unit may be bolted to any substantial, relatively level floor or base. If such a surface is not available, an adequate base must be constructed. Should a concrete base be necessary, make certain the foundation bolts are positioned correctly to accept the receiver feet, and that these bolts project at least 1" (25.4 mm) above the surface of the foundation.

The unit must be levelled and bolted in a manner which avoids pre-stressing the receiver in order to prevent vibration and insure proper operation. The following technique is recommended for anchoring this unit:

- A. Tighten evenly, and to a moderate torque, the nuts of any three of the four receiver feet. Check the unit for level. If the unit is not level, insert metal shims, as shown in Figure 2-2, under one or two of the feet to obtain level, and retighten the nuts.
- B. Note the distance the unanchored foot is elevated above the base and insert a metal shim of equal thickness under this foot to provide firm support. Shims must be at minimum the same dimension as bottom of foot.
- C. After all shims are inserted and the unit is level, pull up the nuts on all receiver feet to a moderate (not excessively tight) torque.
- D. Check for receiver stress by loosening nuts (one at a time), and note any upward movement of the mounting foot. Any noticeable movement indicates that step B must be repeated.

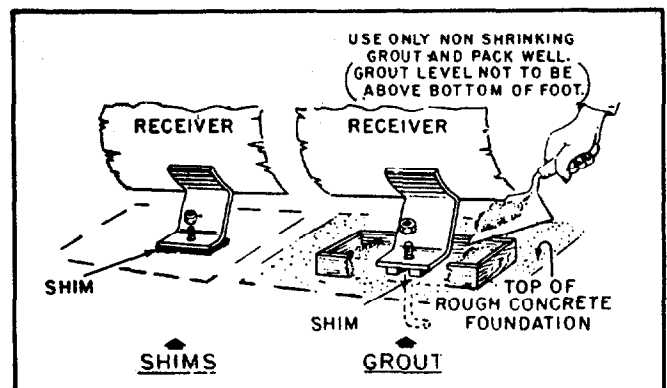

Figure 2-2. Methods of Leveling Unit.

Severe vibration will result when nuts are pulled down tightly and feet are not level. This can lead to welds cracking or fatigue failure of receiver. This is a very important part of installation.

THE COMPRESSOR SHOULD NEVER BE OPERATED WHILE MOUNTED TO THE SHIPPING CRATE SKID.

Step 5. ELECTRICAL WIRING

(See electrical diagrams on Page 28-29)

To avoid invalidating your fire insurance, it is advisable to have the electrical work done by a licensed electrician who is familiar with the regulations of the National Board of Fire Underwriters and the requirements of the local code.

Sizes of copper wire to use for distances up to 100 feet (30.5 m) from the feeder.

| MOTOR HORSEPOWER | SINGLE PHASE | THREE PHASE | | | |
|------------------|-----------------|-----------------|-----------------|----------------------|--|
| | 230V AWG-(75°C) | 200V AWG-(75°C) | 230V AWG-(75°C) | 460V-575V AWG-(75°C) | |
| 5 | 8 | 10 | 12 | 14 | |
| 7½ | — | 8 | 10 | 14 | |
| 10 | — | 8 | 8 | 12 | |
| 15 | — | 4 | 6 | 10 | |

The wire sizes recommended in the above table are suitable for the compressor unit. If other electrical equipment is connected to the same circuit, the total electrical load must be considered in selecting the proper wire sizes. A burned out motor may result unless it is properly protected.

Before wiring the compressor to the power supply, the electrical rating of the motor, as shown on the motor nameplate, must be checked against the electrical supply. If they are not the same, do not connect the motor.

It is important that the wire used be the proper size and all connections secured mechanically and electrically. The size of the wire shown in the table above is a safe guide.

If the distance is more than 100 feet (30.5 m), larger wire will probably be necessary and your electrical contractor or local electric company should be consulted for recommendations. The use of too small wire results in sluggish operation, unnecessary tripping of the overload relays or blown fuses.

FUSES

Fuse failure usually results from the use of fuses of insufficient capacity. If fuses are the correct size and still fail, check for conditions that cause local heating, such as bent, weak or corroded fuse clips. Refer to the table below for recommendations on the proper fuse size to be used.

DUAL ELEMENT FUSE SIZE

| MOTOR HORSEPOWER | VOLTAGE | | | | |
|------------------|--------------|-------------|-----|-----|-----|
| | SINGLE PHASE | THREE PHASE | | | |
| | 230 | 200 | 230 | 460 | 575 |
| 5 | 40 | 25 | 25 | 15 | 10 |
| 7½ | — | 40 | 35 | 20 | 15 |
| 10 | — | 50 | 40 | 20 | 20 |
| 15 | — | 60 | 60 | 30 | 25 |

MAGNETIC STARTER

(See Electrical Diagrams On Page 28-29)

This compressor must be equipped with a magnetic starter. Note that the Pressure Switch (when used), the Oil Level Switch and the On-Off Switch are wired to the operating coil of the magnetic starter and serves to interrupt current flow to the motor.

All starters must include thermal overload protection to prevent possible motor damage from overloading. These starting switches are furnished with the manufacturer's instructions for installation. Ingersoll-Rand cannot accept responsibility for damages arising from failure to provide adequate motor protection.

Step 6. COMPRESSOR STARTUP

Do not connect the compressor piping to your system at this time.

(A) Fill the crankcase to the proper level with the correct grade of lubricating oil. (See Page 11 for Lubrication Specifications.) Tighten the oil plug. **HAND TIGHTEN ONLY.**

(B) Check compressor rotation by flicking "Start-Stop" switch. Rotation is shown by arrow on belt guard back. If rotation is incorrect, interchange two of the three leads on the three phase motors. On single phase motors, refer to reverse wiring diagram on motor name plate.

(C) Prime the condensate trap if supplied on your compressor. (See Page 23 for Priming instructions.) A floor drain should be provided in a nearby location for condensate drainage. A floor drain is desirable whether the compressor is equipped with an automatic condensate trap or not. All compressors will have water condensate in the air receiver.

Your compressor should now be ready for the initial startup and checks. Close the service valve and start the compressor.

NOTE: If equipped with (OPTIONAL) Water Cooled After-cooler, turn on cooling water flow (See Page 22 for Adjustment Procedures).

Step 7. PRESSURE REGULATION

Allow the air receiver to build up to pressure for which you ordered the machine. At this pressure, if the unit is equipped with Automatic Start & Stop regulation, the pressure switch should cause the unit to stop. If the unit is equipped with Constant Speed Control, it should unload (run without compressing air).

Open the service valve and/or drain valve to let pressure in the receiver drop. Note the pressure at which the compressor starts/reloads. If the unit does not Start and Stop/Load and Unload at the correct pressure you may need to adjust, the Pressure Switch/Auxiliary Valve. (See section III, Regulation, if adjustments are necessary).

AIR PRESSURE REGULATOR: The Model 10T3NL incorporates an injected distance piece pressure from the air receiver. This regulator controlled pressure insures a constant 25 to 30 PSIG distance piece pressure during compressor operation. This pressure is piped across to all cylinders and is absolutely vital for the satisfactory operation of the Model 10T3NL compressor.

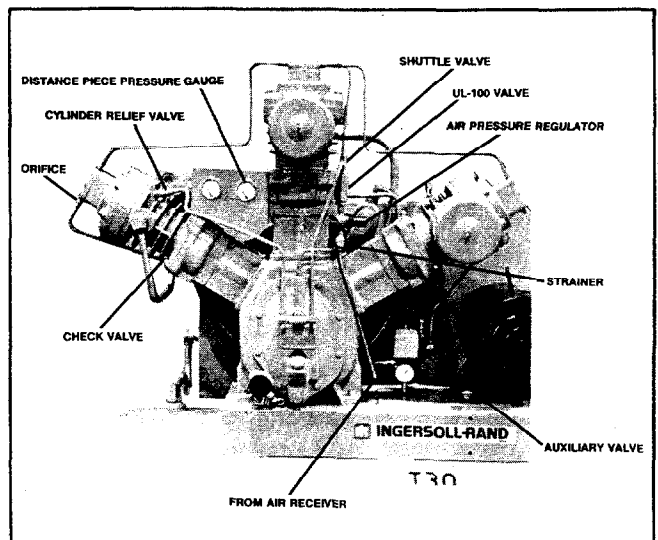

The air pressure regulator is used to adjust the distance piece pressure to a 25 to 30 PSIG pressure setting. After the compressor has raised the air receiver pressure to the normal operating pressure, adjust the air pressure regulator while observing the distance piece pressure gauge. The gauge should read from 25 to 30 PSIG. Pull out on the regulator adjustment

knob to unlock the knob, and turn the adjustment knob clockwise to increase the operating pressure of the regulator. Turn the adjustment knob counter-clockwise to decrease the operating pressure of the regulator. After adjusting to the desired pressure, push-in on the adjusting knob to lock regulator at that pressure setting.

The distance piece pressure gauge should be observed from the initial start-up in case the air pressure regulator has been tampered with after being shipped from the factory. If tampering has occurred, adjustment of the regulator may be required prior to the normal operating air receiver pressure.

Run the compressor for about 5 minutes by bleeding air from the receiver to let the unit warm up and observe for excess vibration or any unusual noise. While the compressor is running, pull ring on all safety valves to be sure they relieve and reseal properly. Do this several times.

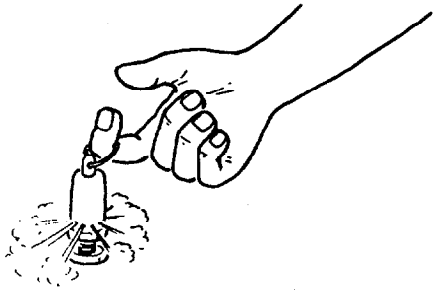

IF YOUR COMPRESSOR DOES NOT OPERATE PROPERLY, SHUT-DOWN IMMEDIATELY, AND CALL YOUR LOCAL INGERSOLL-RAND DISTRIBUTOR.

Step 8. LOW OIL LEVEL SWITCH

An optional float activated switch is available to protect your compressor against damage due to insufficient oil level. The switch operates on a fail-safe principle and is mechanically actuated for sealed, friction-less operation. Low oil level in the frames causes the switch contacts to open, thus shutting the unit down until the proper oil level has been restored.

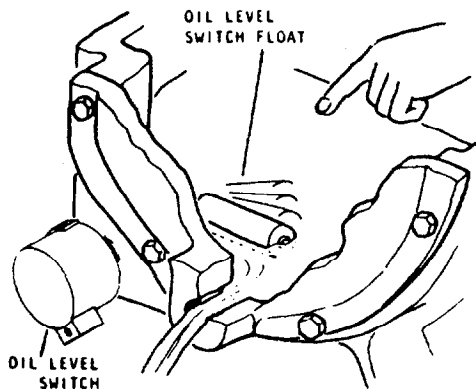

The Low Oil Level Switch is a single pole, double throw snap switch, available with a NEMA 1 or a NEMA 7 enclosure. (See Wiring Diagram on Page 28-29 for connection of the Low Oil Level Switch.)

NEMA 1 ENCLOSURE: This switch has a maximum rating of 5 amps at 125, 250 or 480 volt operation and uses a 3/8" nominal size flexible steel conduit, of a length as required, over the switch lead wires. The switch is not acceptable for greater than 480 volts.

NEMA 7 ENCLOSURE: This switch has a maximum rating of 4 amps at 250 volt operation and is equipped with a 1/2" NPT nonremovable fitting.

WARNING



Hazardous voltage.

Connecting pressure switch or low oil level switch directly to motor can cause severe injury or death.

Always insure the pressure switch or low oil level switch is connected thru the control circuit of a magnetic starter.

During the initial run, stop unit and drain oil from crankcase into clean can until switch clicks or breaks circuit with continuity tester.

This is a "float" type switch which sometimes gets cocked in shipping. If cocked or stuck, open disconnect switch, drain remaining oil, remove crankcase cover and then free the float. Reassemble and then reuse the same oil.

NOTE: If float is cocked in the low position, compressor cannot start.

Step 9 DISCHARGE PIPING

The following general instructions cover only the installation of discharge piping and placement of the pressure switch and safety valves in systems using a detached receiver. Discharge piping should be the same size as the compressor discharge connection or the receiver discharge connection. All pipe and fittings must be certified safe for the pressures involved. Pipe thread lubricant is to be used on all threads, and all joints are to be made up tightly, since small leaks in the discharge system are the largest single cause of high operating costs. If your compressor runs more than you believe it should, the most likely cause is a leaky pipe line. Leaks are easily located by squirting soap and water solution around the joints and watching for bubbles.

When a sub-base mounted unit or a bare compressor is supplied, it is very important to observe the following points when installing the piping between the compressor and the receiver.

WARNING



This machine contains high pressure air which can cause injury or death from flying parts.

If an aftercooler or any other restriction is added to the compressor discharge, a safety valve must be installed between the compressor discharge and the restriction.

1. If possible, run the piping down from the compressor discharge to permit the condensate to drain into the receiver. If this is not possible, install a "drain leg" as shown in Figure 2-3. The drain leg should project down from the compressor discharge and be at least 10" (254 mm) long. Put a drain valve at the end of this pipe and drain at least weekly, or as often as necessary.

PRESSURE SWITCH, AUXILIARY VALVE AND PRESSURE GAUGE - If a receiver mounted unit is purchased, a pressure gauge, auxiliary valve and/or pressure switch will be mounted on the receiver.

If the receiver is detached as shown in Figure 2-3, these items must be installed and connected by the customer. Make certain that they are located high enough on the receiver to prevent condensate from draining into them.

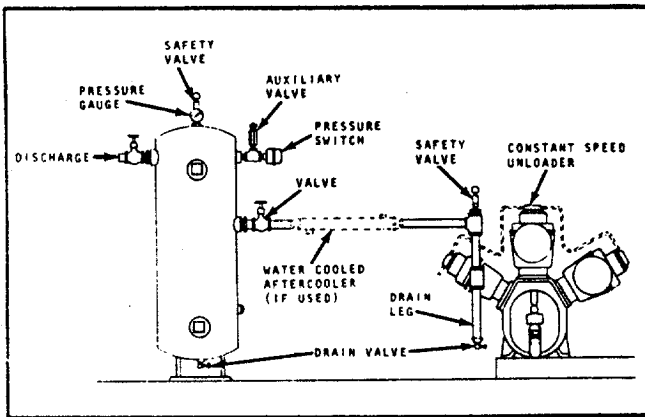

Figure 2-3. Typical piping arrangement for compressor and detached receiver.

The length of the tube line connecting the auxiliary valve to the constant speed unloaders will have a bearing on the operation of the regulation system. Determine the maximum tube length experimentally, and if it is necessary to install the auxiliary valve closer to the compressor, select a pulsation free point in the discharge line that registers actual receiver pressure and mount the valve in an upright position. If necessary, the auxiliary valve may be connected to a small surge tank installed in the discharge line close to the compressor discharge.

Step 10. COMPLETE WARRANTY REGISTRATION _____

Completion of the registration form indicates satisfactory installation and performance of start-up operations. If any defects are apparent in the equipment; contact the nearest I-R Distributor or Ingersoll-Rand District office. The I-R service literature included with the unit has instructions for minor adjustments. Minor adjustments are not considered warranty.

SECTION III REGULATION

TYPES OF REGULATION _____

Your compressor may be regulated by one of the following methods:

AUTOMATIC START & STOP CONTROL - Makes or breaks electrical contact to the motor at predetermined pressures. This type of regulation is used when the demand for air is small or intermittent, but where pressure must be continuously maintained.

CONSTANT SPEED CONTROL - Unloads the compressor at a predetermined pressure while the motor continues to operate. This type of regulation is used when the demand for air is practically constant at the capacity of the compressor.

DUAL CONTROL — Permits a manual selection between Automatic Start and Stop Control and Constant Speed Control, depending upon the air requirements.

AUTOMATIC START AND STOP CONTROL _____

Automatic Start and Stop Control is obtained by means of a pressure switch which makes the breaks an electrical circuit, starting and stopping the driving motor, thereby maintaining the air receiver pressure within definite limits. The pressure switch is piped to the receiver and is actuated by changes in air receiver pressure.

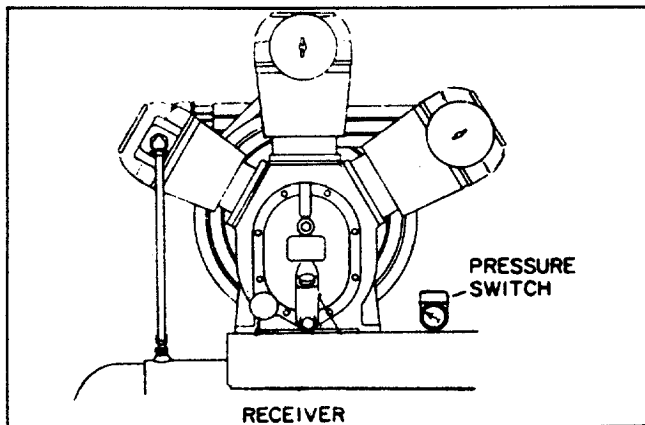

Figure 3-1. Typical Automatic Start and Stop arrangement.

PRESSURE SWITCH ADJUSTMENT _____

The pressure switch has a Range Adjustment and a Differential Adjustment. See Figure 3-2. The Cut-out (Compressor Shut-down) is the pressure at which the switch contacts open, and the Cut-in (Compressor Restart) is the pressure at which the switch contacts close.

The cut-out point may be increased by screwing the range adjustment clockwise. Screwing the range adjustment counter-clockwise decreases the cut-out point. Note the pressure gauge reading at which the compressor cuts-in and out and re-establish pressure setting if necessary.

The differential pressure may be increased by screwing the differential adjustment clockwise. Backing off the differential adjustment will narrow the span. It is advisable to have as wide a differential as possible to avoid frequent starting and stopping of the compressor. Note the pressure gauge reading at which the compressor cuts-out and re-establish this point if necessary.

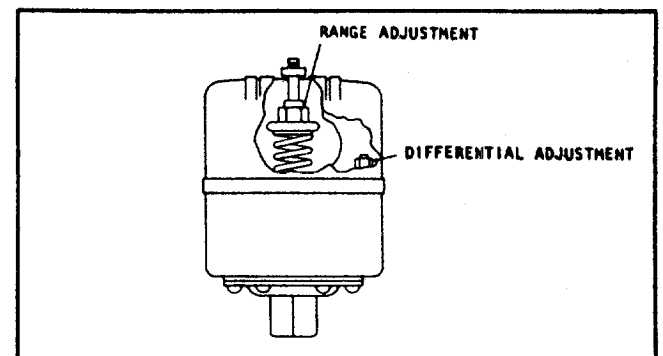

Figure 3-2. Typical pressure switch cut-in and cut-out adjustment.

NOTE: There is interaction between these two adjustments, i.e., if the cut-out is increased, the differential will also increase, or if the differential is narrowed, the cut-out will be reduced, etc. These factors must be considered when adjusting the switch and compensate for accordingly.

CONSTANT SPEED CONTROL

Constant Speed Control is obtained by means of an auxiliary valve that controls the operation of the Constant Speed Unloaders, thereby loading and unloading the compressor in accordance with air receiver pressure. This action maintains receiver pressure within definite limits while the compressor continues to operate.

The auxiliary valve is piped directly to the receiver, and the valve opens when receiver pressure exceeds the preset pressure of the valve spring, unseating the ball piston. This action permits receiver pressure to pass directly to the Constant Speed Unloaders. See Figure 3-6.

When the pressure enters the constant speed unloaders, it forces the unloader plate down against the resistance of the

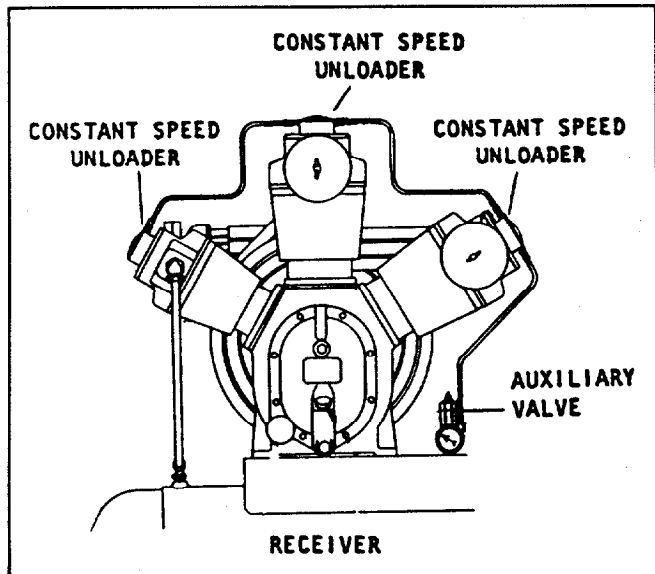

Figure 3-3. Typical Constant Speed Control arrangement.

unloader spring. Pins on the lower end of the unloader plate engage the inlet valve plate, forcing it down and holding the inlet valve open. The compressor is now operating unloaded, since air will surge in and out of the open valves but will not be compressed.

When the receiver pressure falls below the pressure differential for which the auxiliary valve is set, the valve closes, and the pressure to the unloaders is shut off directly by the auxiliary valve. With the receiver pressure removed from the unloaders, the unloader spring returns the unloader plate to the top of the airhead cover. The unloader pins now disengage the inlet valve plate and since the inlet valve is now permitted to operate normally the compressor reloads.

DUAL CONTROL

Dual Control is accomplished by adjusting the lockout knob on the top of the auxiliary valve. See Figure 3-4. For constant speed operation, turn the knob counterclockwise until fully open. This adjustment will allow the valve to function. Turning the knob clockwise locks-out rotation. Note the pressure gauge reading at which the compressor cuts-out and re-establish this point if necessary.

NOTE: For proper dual control operation, the cut-out setting of the pressure switch must be at least 5 psig greater than the cut-out pressure of the auxiliary valve.

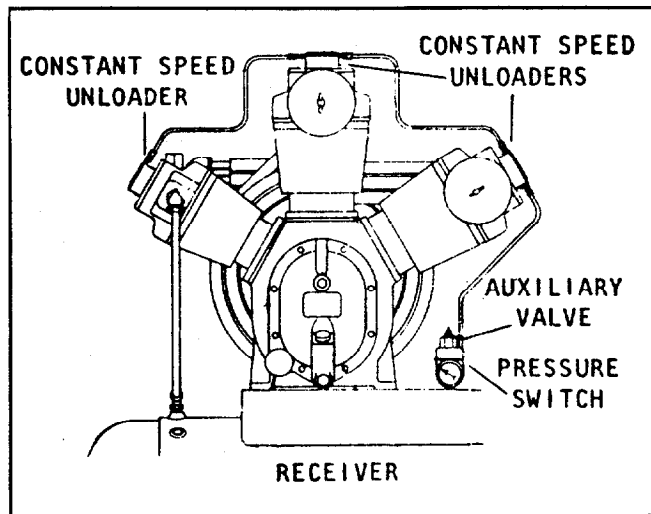

Figure 3-4. Typical Dual Control arrangement.

AUXILIARY VALVE ADJUSTMENT

The auxiliary valve should be mounted on the receiver, if possible, and piped to the unloaders. Install the auxiliary valve in the vertical position at a location that is free of vibrations.

The valve has a cut-out and a differential adjustment. The cut-out point is the pressure at which the valve will open allowing the compressor to unload, the cut-in point is the pressure at which the valve will close allowing the compressor to reload, and the differential is the span between the cut-out and the cut-in points.

To adjust the cut-out pressure, (See Figure 3-5), loosen the range locknut and turn the range adjustment screw clockwise for higher pressure and counterclockwise for lower pressure. Retighten the range locknut after adjusting the cut-out pressure.

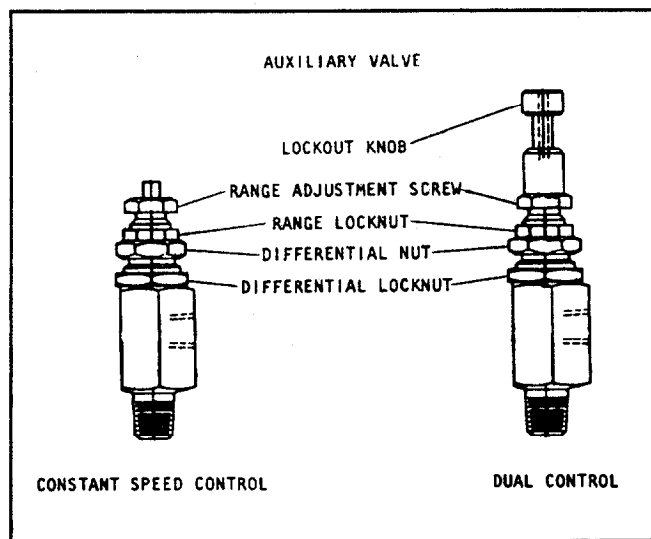

Figure 3-5. Typical Auxiliary Valve adjustments.

The differential pressure will vary with the change in cut-out pressure.

The differential pressure is preset at approximately 15% of the cut-out pressure and should not be re-adjusted unless absolutely necessary. Small differentials, 5 PSIG or less, tends to produce internal chattering and should be avoided.

To adjust the differential pressure, (See Figure 3-6), loosen the differential locknut and turn the differential nut clockwise for greater differential and counterclockwise for less differential. While adjusting the differential nut, the range locknut should be

loosened and the range adjustment screw must be held from turning to avoid changing the cut-out pressure. Retighten the differential locknut and the range locknut after adjusting the differential pressure.

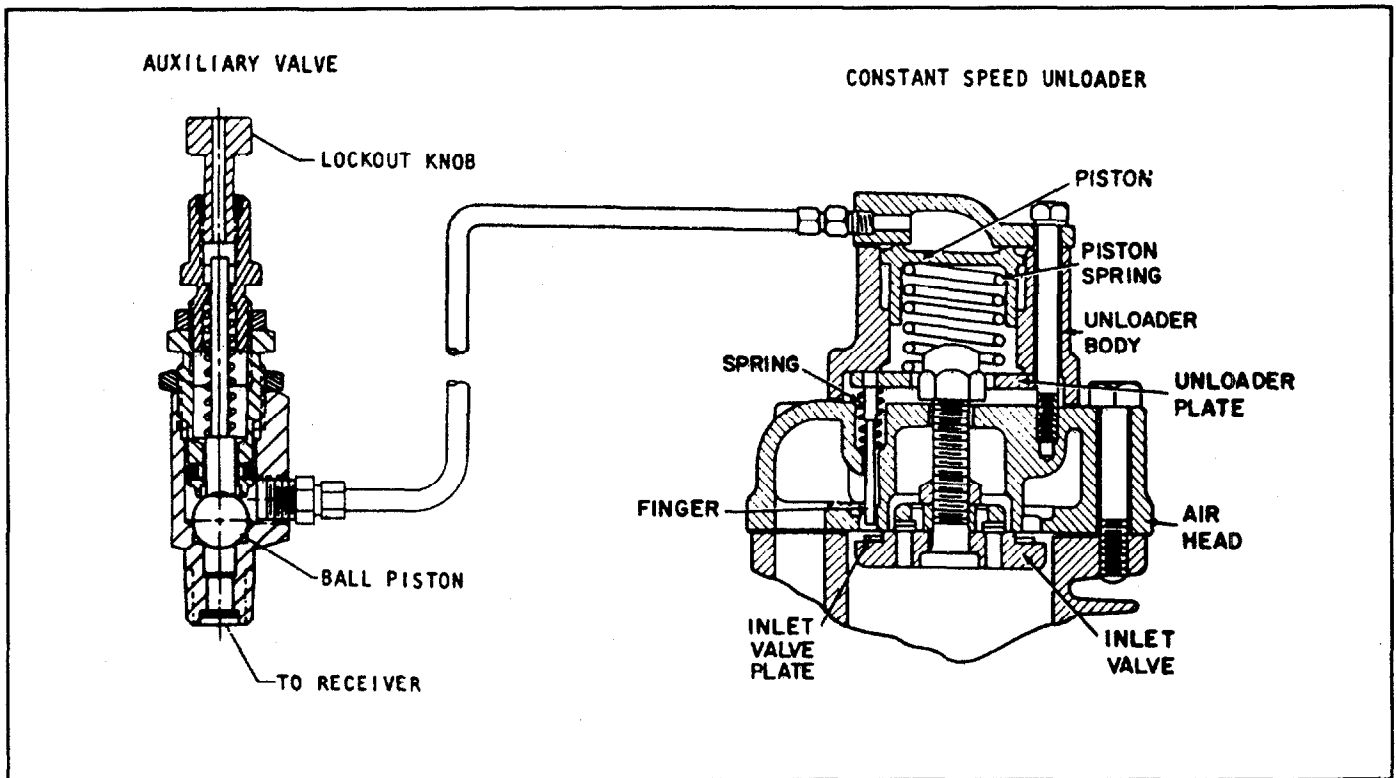

Figure 3-6. Auxiliary Valve and Constant Speed Unloader.

SECTION IV OPERATION

OPERATING CHECKS

Satisfactory operation of any piece of mechanical equipment depends, to a large degree, upon adherence to a preventive maintenance schedule.

To obtain optimum performance at minimum cost, observe the "Maintenance" guide on page 18.

COMPRESSOR LUBRICATION

FRAME OIL CHANGES — Oil changes should be made every 500 hours of operation or every 90 days, whichever occurs first. Important: For maximum removal of impurities, drain only when frame oil is hot. After the operator has observed the condition of

the oil from a number of changes, the length of time between changes may be extended if so warranted. Frame oil capacity for the Model 5T2NL is 2 quarts (1.89 liters), and the Model 10T3NL is 3 quarts (2.84 liters).

LUBRICATING OIL RECOMMENDATIONS

Although Ingersoll-Rand does not recommend any particular brand of lubricating oil, a non-detergent, petroleum lubricating oil containing only rust, oxidation, and anti-foaming inhibitors may be used in any TYPE 30 product. The petroleum lubricating oil may be Naphthenic or Paraffinic based.

The viscosity should be selected for the temperature immediately surrounding the unit when it is in operation. Synthetic oils are not recommended in the non-lube compressors.

Check the oil level in the bare compressor before each use by removing the oil filler plug and wiping clean. Place the oil gauge into the filler hole until the threads touch (DO NOT ENGAGE THE THREADS.) Remove the gauge and read the oil level. If oil level drops below the safe point, add oil to bring level back to the FULL mark. Do not over fill. Replace oil plug HAND TIGHTEN ONLY.

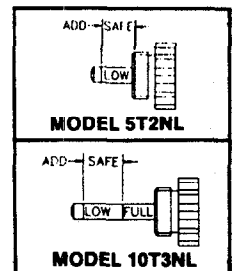

WARNING



Flushing compressor frame with gasoline, kerosene or flammable fluid can cause severe injury or death.

Use a regular flushing oil to flush out compressor frame.

OIL VISCOSITY TABLE

| Temp. Range | Viscosity at 100° F (37.8°C) | |
|----------------------------------|---------------------------------|-------------|
| | SSU | Centistokes |
| 40°F & Below (4.4°C & Below) | 150 | 32 |
| 40°F to 80°F (4.4°C to 26.7°C) | 500 | 110 |
| 80°F to 125°F (26.7°C to 51.7°C) | 750 | 165 |

The viscosities given in the table are intended as a general guide only. Heavy-duty operating conditions require heavier viscosities, and where borderline temperature conditions are encountered the viscosity index of the oil should be considered. Always refer your specific operating conditions to your industrial lubricant supplier for recommendations.

MOTOR LUBRICATION & CARE

Depending upon the type of electric motor driving your unit, the following lubricating schedule should be observed.

SLEEVE BEARING MOTORS - Are to be oiled at least once every three months with an oil of a viscosity of 150 to 230 SSU at 100°F (32 to 55 centistokes at 37.8°). Note: Do not fill the oil reservoir with an excessive amount of oil, since it may work onto the commutator.

BALL BEARING MOTORS WITH GREASE FITTINGS - Ball bearing motors that have grease fittings and plugs near the bearings are to be repacked with grease once a year. Use a very good grade of ball bearing grease.

BALL BEARING MOTORS PRELUBRICATED FOR LIFE - These motors have no grease fitting or plugs near the bearing and do not require lubrication.

Several major points contributing to proper motor operation and care are given in the following paragraphs. For more detailed instructions, refer to the manufacturers' specific recommendations.

On some types of motors, such as direct current and single-phase motors, the commutator and brushes should be cleaned periodically with a piece of canvas or non-linting cloth. If the commutator of any motor becomes contaminated with oil or grease, it should be cleaned immediately by a competent electrician, otherwise serious damage will result.

It is also a good practice to monthly blow off the motor windings with a jet of air to prevent an accumulation of dirt. An occasional revarnishing of the windings will greatly prolong the life of the motor.

If it is ever necessary to renew the brushes, they must be carefully sanded to fit the contour of the commutator, and the brushes must be made to fit loosely in their holders. Do not use emery cloth for fitting purposes.

If the motor is located in an atmosphere where it is exposed to appreciable quantities of water, oil, dirt or fumes, it must be specially constructed.

AIR INLET FILTER/SILENCER

It is very important that the air inlet filter/silencer be kept clean at all times. A dirty inlet filter reduces the capacity of the compressor.

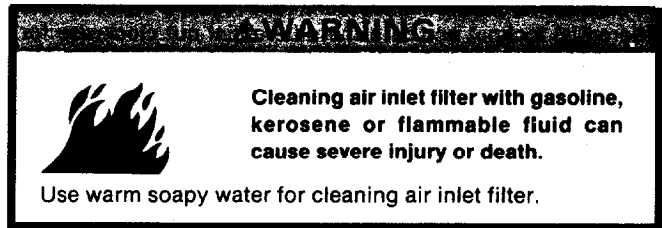

The filtering element should be taken out at least once a month and cleaned by vacuuming or washing in mild detergent and water. Allow to dry and then reinstall.

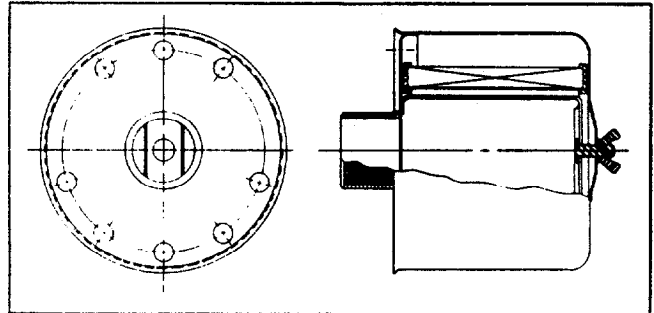

Figure 4-1. Air Inlet Filter/Silencer.

The standard inlet air filter is suitable only for normal industrial applications. Should the compressor be located in an area where the atmosphere contains a heavy concentration of dust and dirt, an air filter utilizing a specially designed, heavy duty (4 micron) element should be used.

All applications of this nature should be referred to the nearest Ingersoll-Rand sales office or distributor.

BREATHER TRAP

The breather trap mounts directly to the compressor frame and vents to atmosphere through the breather trap exhaust line. A filtering element is located in the top of the breather trap which serves to prevent oil from leaving the frame in the vented air flow. When the compressor shuts down, the trapped oil drips into the frame, preventing oil carry-over to atmosphere. The pilot valve is also vented to the side of the breather trap to prevent loss of oil to atmosphere and to minimize noise when compressor unloads.

THE BREATHER TRAP FILTERING ELEMENT SHOULD BE CLEANED AFTER EVERY 500 HOURS OF OPERATION.

INTERCOOLER

This compressor is equipped with an intercooler between the first-stage and the second-stage. See Figure 4-2. The purpose of the intercooler is to remove most of the heat of the first-stage compression from the air before it enters the second-stage, thus improving efficiency and decreasing the final discharge air temperature.

The intercooler consists of one or more finned tubes connecting the discharge of the first-stage to the inlet of the second-stage. The compressed air flows through these tubes and its heat is transferred to the cooling fins, where the air from the belt wheel fan passing over the fins dissipates the heat to atmosphere.

Never permit the air flow to these tubes to become obstructed, and clean the surfaces of the tubes whenever deposits of oil, dirt or grease are observed. Use a non-flammable safety solvent for cleaning purposes. During regular overhaul periods, the tubes should be removed from their headers and inspected internally. If the interior of the tubes requires cleaning, cap one end and fill it with a non-flammable safety solvent to help loosen internal deposits of oil, dirt and carbon. Always flush the tubes with warm water and permit them to dry thoroughly before replacing.

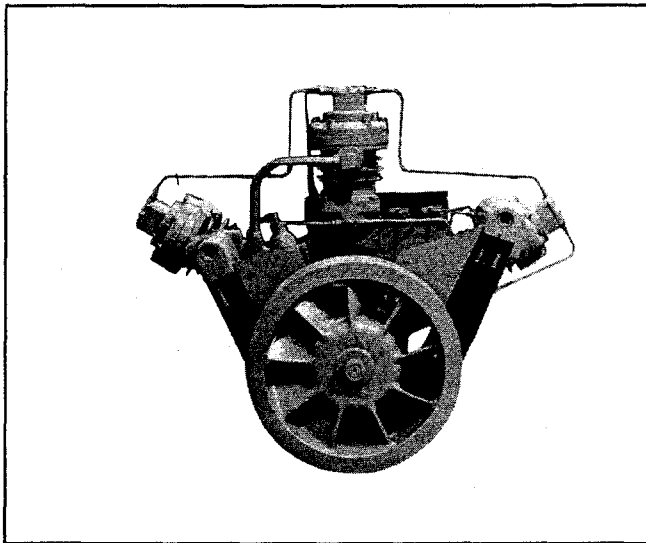
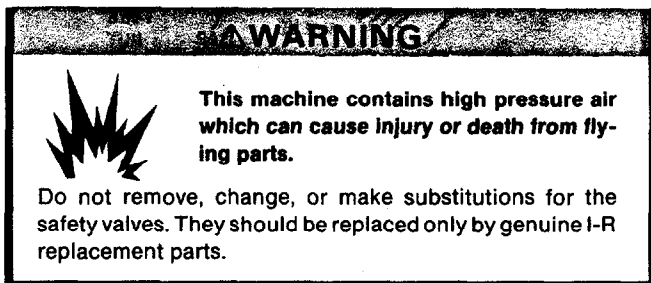

Figure 4-2. Intercooler Tubes and Safety Valves.

SAFETY VALVE



Safety Valves are designed to protect against damage from over pressure. This compressor will be furnished with the following safety valves.

1. Intercooler Safety Valve - All units will be supplied with one 60 psig safety valve installed in the intercooler. See Figure 4-2.
2. Receiver Safety Valve - Receiver mounted units will be supplied with a 135 psig safety valve installed in the receiver.

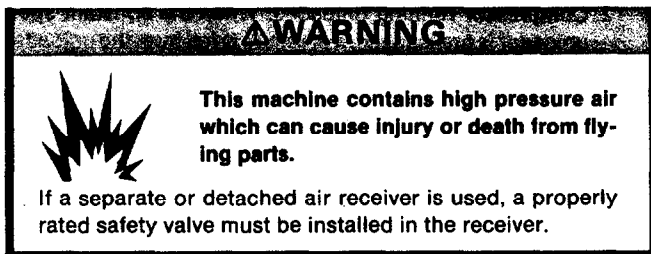

3. Discharge Safety Valve - On units that are supplied with a water-cooled or air-cooled aftercooler there will be a 325 psig safety valve installed between the compressor discharge and the cooler.

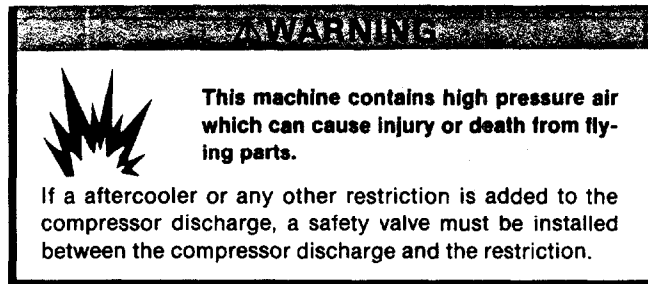

STARTING UNLOADING

OPERATION OF STARTING UNLOADING SYSTEM — The purpose of the system is to relieve cylinder pressure when the compressor stops permitting it to start against a light load; increasing the life of the driver and belts and also reducing the possibility of tripping the overload relay. The system operates in the following manner:

As shown in Figure 4-3, the centrifugal unloader is attached to the end of the crankshaft, thus when the compressor is in operation, centrifugal force acts upon the unloader weights and they swing outward. (See Figure 4-4). When the compressor stops, these weights retract, (Figure 4-3) permitting the thrust pin spring to move the plunger and thrust pin outward. The thrust pin opens the pilot valve and pressure bleeds from the cylinders to atmosphere via the path shown in Figure 4-3. The cylinders and intercooler are now relieved of all pressure and the compressor is unloaded.

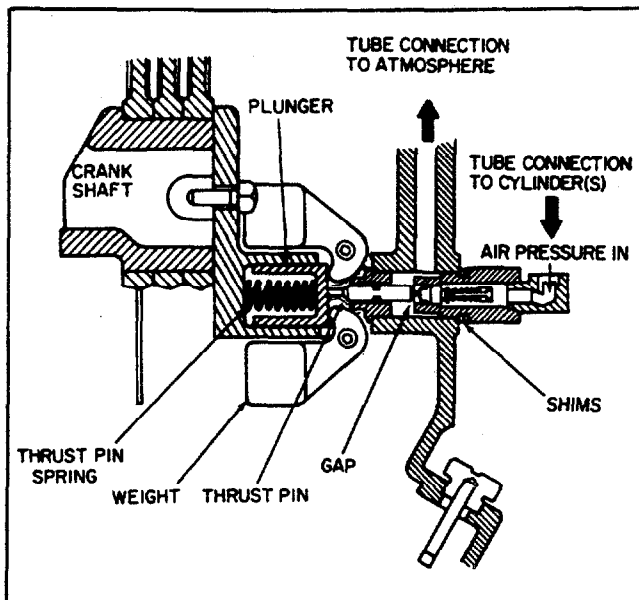

Figure 4-3. Position of weight and thrust pin when compressor is stopped.

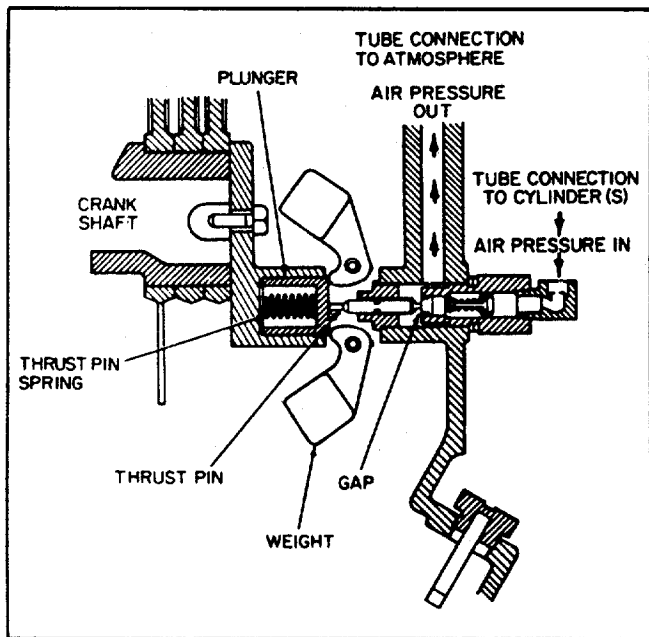

Figure 4-4. Position of weight and thrust pin when compressor is operating.

When the compressor starts, centrifugal force acts upon the unloader weights and they swing outward. This permits the plunger and thrust pin to move inward and the pilot valve to close. The escape path to atmosphere for the cylinder pressure is now closed and the compressor pumps air in a normal manner.

If the pilot valve tube line is excessively hot, it is a good indication that the pilot valve is leaking and adjustment is required.

PILOT VALVE ADJUSTMENT - To adjust the pilot valve, refer to Figure 4-3, and proceed as follows:

1. Stop the compressor. (Disconnect the electrical supply main switch to prevent accidental start-up.)
2. Remove the pilot valve tube and tube fittings.
3. Remove the pilot valve body and all existing shims.
4. Screw the pilot valve body back into the frame end cover (without any shims) until contact with the thrust pin is felt. Advance the pilot valve body $\frac{1}{4}$ to $\frac{1}{2}$ turn more.

NOTE: If contact with the thrust pin cannot be felt, the following steps may be necessary to locate the contact point.

- a. Insert a small instrument (Punch, rod, nail, etc.) into the end of the pilot valve until it contacts the valve stem.
- b. While still inserted in the pilot valve, make a mark on the instrument even with the outside edge of the pilot valve body.
- c. Keeping the instrument pressed lightly against the valve stem, screw the pilot valve body into the frame end cover. When the mark on the instrument starts moving out away from the edge of the pilot valve body, contact has been made with the thrust pin.
- d. Advance the pilot valve body $\frac{1}{4}$ to $\frac{1}{2}$ turn more and proceed with step five.

5. Measure the gap between the pilot valve body and the frame end cover.

6. Remove the pilot valve body and add enough shims to fill the gap measured in step five.
7. Screw the pilot valve body back into the frame end cover until the body is tight on the shims.
8. Reconnect the pilot valve tube and tube fittings.

If leakage still exists repeat the above steps. If leaking cannot be stopped by adjustment, replacement of the pilot valve may be required. Use the above procedure, starting with step four, when installing the new pilot valve.

CYLINDER RELIEF VALVE—The cylinder relief valve, located in the cylinder, acts as a check valve to prevent air from surging in and out of the pilot valve tube line; thereby, maintaining a high volumetric efficiency. This valve is not adjustable. If it leaks and a thorough cleaning does not correct the problem, replace the internal valve parts.

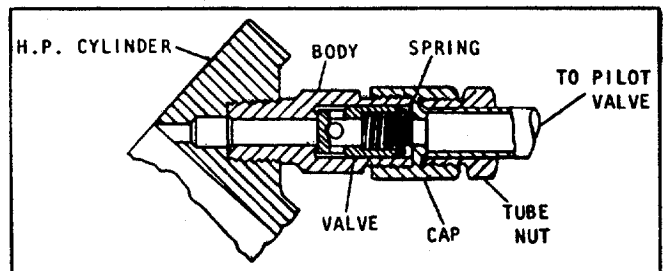

Figure 4-5. Cylinder relief valve.

DISTANCE PIECE PRESSURE SYSTEM

A positive air pressure in the distance piece is absolutely vital to insure oil free air from the compressor discharge. The oil free air pressurizing the distance piece causes a flow from the distance piece into the frame thereby preventing oil vapor present in the frame from entering the distance piece. Thus, with the air in the distance piece being oil free, no oil can enter the compression chamber. This is accomplished as follows:

MODEL 5T2NL

1. Compressor running loaded: A small hole in the low pressure piston bleeds air into the distance piece. An equalizing line connects all distance pieces to balance this pressure.
2. Compressor running unloaded: When the constant speed unloader is pressurized, a pressure is fed from the unloaders through an orifice and check valve into the distance piece. The check valve prevents flow back into the unloaders, when no pressure exists in the constant speed unloaders.

The four-ring design crosshead allows sealing of the air between the rings and the crosshead. The oil scrapper ring is placed above the oil control ring to scarp oil into the compressor frame and to prevent oil from entering the distance piece. The bottom oil control ring still allows adequate lubrication for the crosshead and crosshead guide.

MODEL 10T3NL

The Model 10T3NL is similar in operation to the 5T2NL. To insure a proper distance pressure on the three-cylinder compressor, an injected air flow from the air receiver to the distance piece is used.

1. Compressor running loaded: A positive air pressure is applied to the UL-100 valve from the second stage through

the cylinder relief valve. The pressure opens the UL-100 valve allowing air receiver pressure to flow through a strainer, air pressure regulator (Set a 25 to 30 PSIG), and into the distance piece. The air pressure regulator maintains a consistent 25 to 30 PSIG in the distance piece during all load conditions.

2. Compressor running unloaded (Does not apply to Auto Start and Stop Control Models): When the constant speed unloaders are pressurized, air pressure is forced to the shuttle valve and the UL-100 valve from the unloaders. The air pressure moves the shuttle valve seal in the opposite direction from the loaded cycle and allows the air to enter

the distance piece from the air receiver. Unload cycle distance piece pressure is approximately 5 PSIG less than in the load cycle.

3. Shutdown conditions: The UL-100 valve is a normally closed pneumatic device. It will remain closed until a direct air pressure is applied to either side. When the compressor shutdown, the pilot valve unloads removing the air pressure from the UL-100 valve which closes the valve, and prevents air pressure from entering the distance piece. This prevents air loss from the air receiver when the compressor is not in operation.

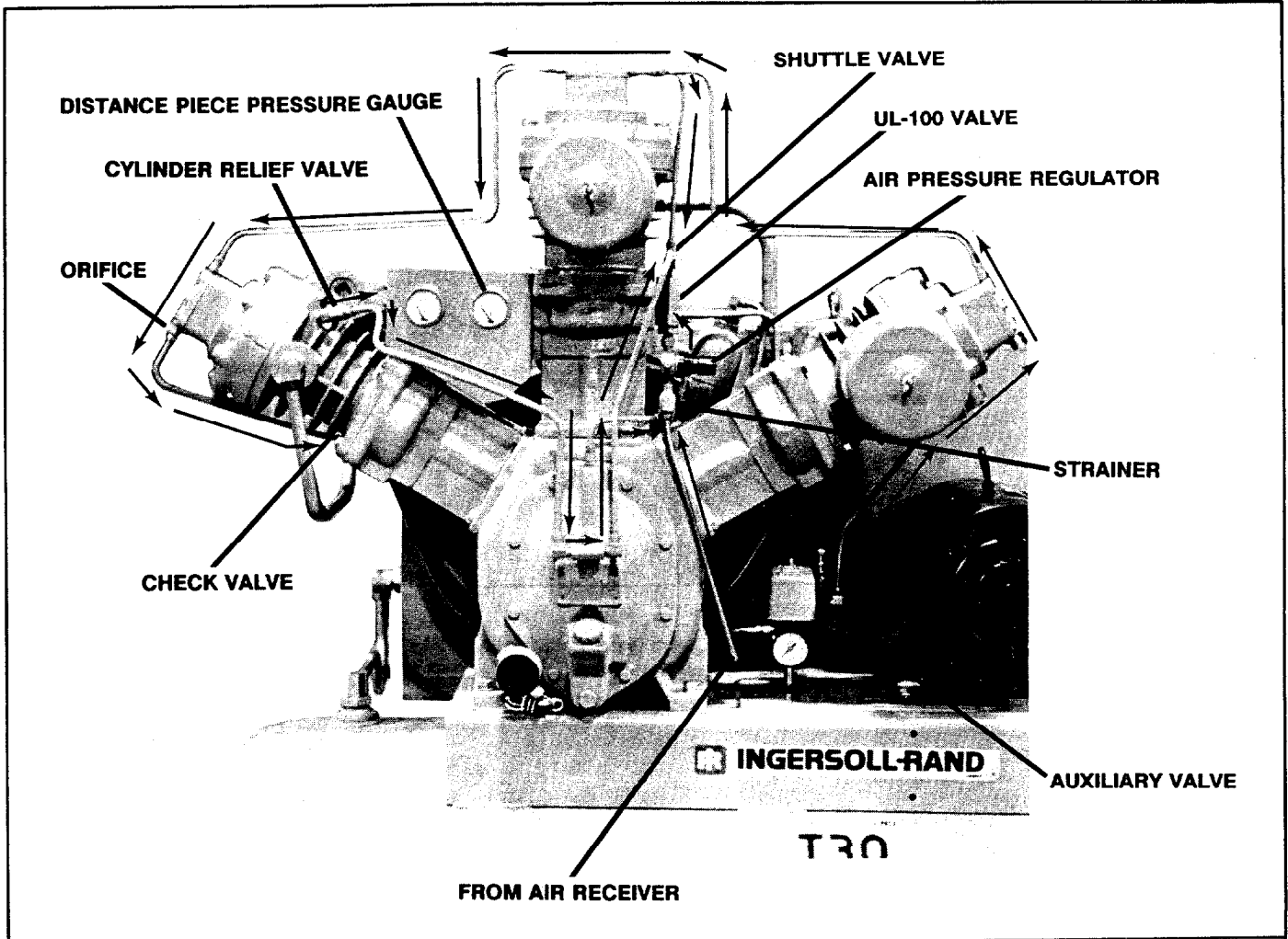

Figure 4-6. Compressor Identification Chart

LEGEND

MODEL 5T2NL

1. Distance Piece Balanced Pressure Line
2. Distance Piece Air Pressure Gauge
3. Cylinder Relief Valve
4. Cylinder Relief Valve Line
5. Pilot Valve
6. Frame Vent Line
7. Breather Trap
8. Breather Trap Exhaust Line
- * 9. Auxiliary Valve Line
- * 10. Auxiliary Valve
- * 11. Constant Speed Unloaders Connecting Line
- * 12. Orifice
- * 13. Distance Piece Pressure Line
- * 14. Check Valve
15. Intercooler Air Pressure Gauge
16. Compressor Discharge Line
17. Air Receiver Pressure Gauge

* Not supplied with Auto-Start-And-Stop Control Models.

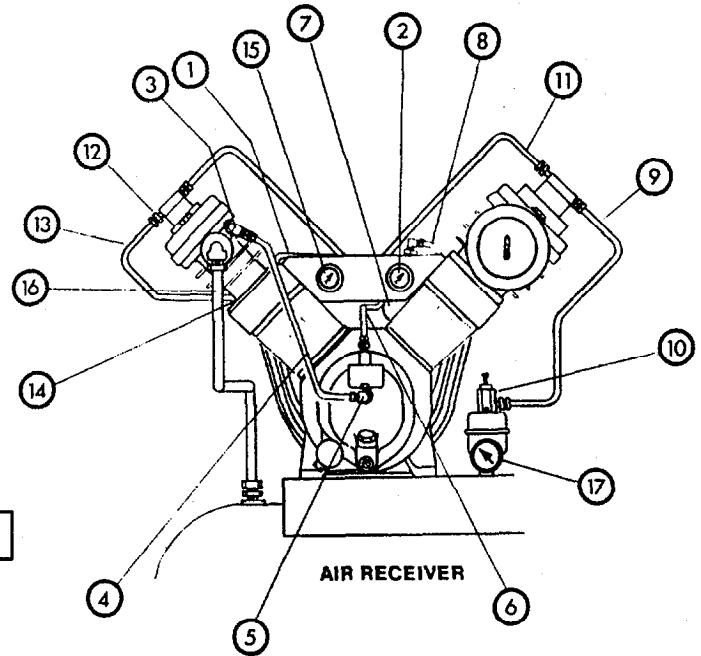

Figure 4-7. Compressor Identification Chart

LEGEND

MODEL 10T3NL

1. Air Receiver Pressure Line
2. Distance Piece Air Pressure Regulator
3. UL-100 Valve Assembly
4. Cylinder Relief Valve
5. Cylinder Relief Valve Line
6. Pilot Valve
- * 7. Shuttle Valve (Elbow Supplied On Auto-Start-And-Stop Models)
8. Distance Piece Balanced Pressure Line
9. Distance Piece Air Pressure Gauge
- * 10. Constant Speed Unloaders Connecting Line
- * 11. Orifice
- * 12. Distance Piece Pressure Line
- * 13. Check Valve
14. Frame Vent Line
15. Breather Trap
16. Breather Trap Exhaust Line
17. Intercooler Air Pressure Gauge
- * 18. Auxiliary Valve Line
- * 19. Auxiliary Valve
20. Compressor Discharge Line
21. Air Receiver Pressure Gauge
22. Strainer

* Not supplied with Auto-Start-And-Stop Control Models.

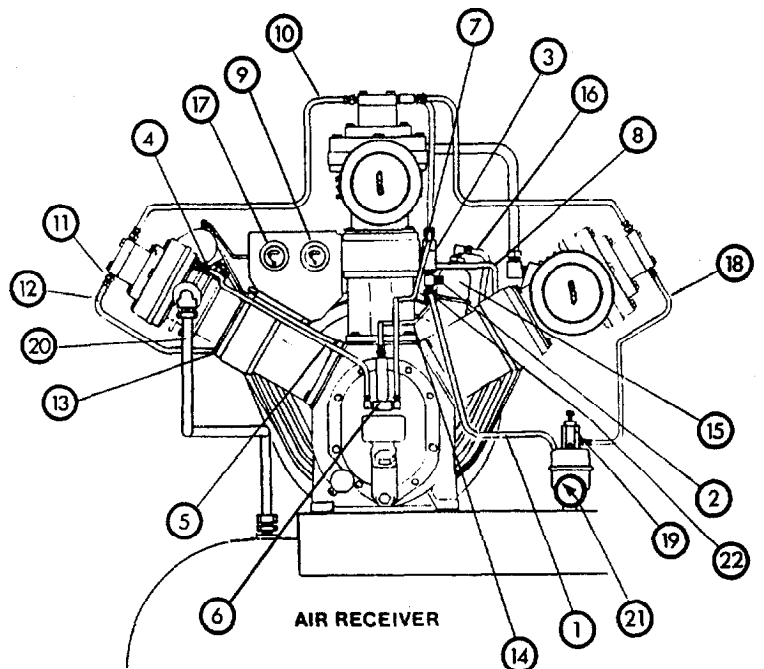

SECTION V

TROUBLE GUIDE

| TROUBLE | CHECK POINT NUMBERS |
|---|------------------------------|
| Oil in disch air | 8-10-24-33-35-36-37 |
| Knocks or rattles | 2-3-20-21-22-23 |
| Water hammer (On units equipped with Water-cooled aftercoolers) | 26 |
| Air delivery has dropped off | 1-2-6-18-20-29 |
| Intercooler safety valve pops or high pressure gauge reading | 20-31 |
| Trips motor overload or draws excessive current | 9-14-15-16-17-18-20-22-23-32 |
| Water in frame or rusting in cylinders | 12-13 |
| Machine won't unload | 21 |
| Auxiliary valve chatters, leaks around stem | 21 |
| Excessive starting and stopping (auto start) | 4-6-7-14 |
| Compressor doesn't unload when stopped | 18-36-37 |
| Compressor runs excessively hot | 2-5-7-11-20-27 |
| Compressor won't come up to speed | 15-18 |
| Lights flicker when compressor runs | 15-16 |
| Abnormal piston, ring or cylinder wear | 28-29 |
| High reading on distance piece press gauge | 19-25-29-33 |
| Low reading on distance piece press gauge | 30-35-36-37 |
| Oil seal leaks | 33-34 |

| CHECK POINT NUMBERS | TROUBLE CAUSE |
|---------------------|--|
| 1. | Clogged inlet filter/silencer(s). |
| 2. | Leaking cylinder relief valve. |
| 3. | Loose belt wheel or motor pulley or motor with excessive end play in shaft. |
| 4. | Receiver needs draining. |
| 5. | Air to fan wheel blocked off. |
| 6. | Air leaks in piping. (on machine or in outside system) |
| 7. | High pressure discharge valve leaking. |
| 8. | Oil viscosity too low. |
| 9. | Oil viscosity too high. |
| 10. | Oil level too high. |
| 11. | Oil level too low. |
| 12. | Detergent type oil being used. Change to non-detergent type with rust and oxidation inhibitor. |
| 13. | Extremely light duty or located in a damp humid spot. |
| 14. | Should have constant speed control due to steady demand. |
| 15. | Check line voltage, motor terminals for good contact, tight starter connections, proper starter heaters, fuses, wire size. |
| 16. | Poor power regulation (unbalanced line). Consult with power company. |
| 17. | V-Belts pulled excessively tight. |
| 18. | Leaking or maladjusted centrifugal pilot valve, or defective O-Ring on pilot valve. |
| 19. | Blocked bleed holes in crosshead ring groove. |
| 20. | Leaking, broken, or loose valves. |
| 21. | Leaking, broken or worn constant speed unloader parts. Aux. valve dirty, seats worn. |
| 22. | Worn or scored connecting rod, piston pin or crank pin bearings. |
| 23. | Defective ball bearing on crankshaft or on motor shaft. Loose motor fan. |
| 24. | Oil control ring broken or not seated in, stuck in groove, rough, scratched or excessive end gap (over .020" worn) (.508 mm) or side clearance (over .006") (.152 mm). |
| 25. | Cylinders or piston rings scratched, worn or scored. |
| 26. | Adjust rate of water flow through aftercooler. |
| 27. | Wrong direction of rotation. |
| 28. | Extremely dusty atmosphere. Need more effective air inlet filter/silencer. |
| 29. | NL piston rings scratched, broken or worn. |
| 30. | Stuck, plugged orifice or check valve. (constant speed or dual control). |
| 31. | High press inlet valve leaking. |
| 32. | Scuffed crosshead or crosshead guide. |
| 33. | Plugged oil separator filter. |
| 34. | Oil seal worn or shaft scored. |
| 35. | Bad air pressure regulator or wrong regulator setting. |
| 36. | UL-100 Valve clogged or leaking internally. |
| 37. | Shuttle valve stuck or blocked. |

SECTION VI MAINTENANCE

WARNING



This machine contains high pressure air which can cause injury or death from flying parts.

Always release pressure from compressor and air receiver before removing caps, plugs, fittings, covers, etc.



Hazardous voltage.

Can cause severe injury or death.

Disconnect main power before servicing compressor.

| MAINTENANCE OPERATION | SERVICE INTERVAL | | | | |
|---|--|--------|--------|---------|---------|
| | Operating Hours/Months - whichever comes first | | | | |
| | 500/3 | 1000/6 | 1500/9 | 2000/12 | 2500/15 |
| COMPRESSOR | | | | | |
| Check Distance Piece Pressure Gauge | Daily | | | | |
| Frame Oil Level - Check | Daily | | | | |
| Air Inlet Filter - Inspect and Clean | Weekly | | | | |
| Inspect Oil for Contamination --Change if necessary | Monthly | | | | |
| Frame Oil - Change - Petroleum Lube | X | X | X | X | X |
| Unloader O-Rings -Teflon Lub on Unloader O-Ring | X | X | X | X | X |
| Compressor Valves - Inspect, Clean or Replace | X | X | X | X | X |
| Breather Trap Filter Element - Clean or Replace | X | X | X | X | X |
| Non-Lube Rings -Inspect Teflon and Carbon Rings --Replace if necessary. | | | | X | |
| Intercooler - Clean Exterior | Weekly | | | | |
| Low Oil Level Switch - Check Operation | X | X | X | X | X |
| Operate Safety Valves - Manually | Weekly | | | | |
| Clean Cylinder Cooling Fins | Weekly | | | | |
| V-BELT DRIVE | | | | | |
| Belt Tension - Check | Monthly | | | | |
| MOTOR | | | | | |
| Motor Bearings - Check and Lubricate | | | | X | |
| Clean | Monthly --(Weekly in Dusty Locations) | | | | |
| AFTERCOOLER | | | | | |
| Aircooled: Clean externally | Monthly -- (Weekly in Dusty Locations) | | | | |
| Clean air flow internally | | X | | X | |
| Watercooled: Check discharge water temp.-120°F max | | X | | X | |
| Check water flow rate | Weekly | | | | |
| RECEIVER | | | | | |
| Drain Condensate - Manual | Daily | | | | |
| Operate Safety Valves | Monthly | | | | |
| GENERAL | | | | | |
| Tighten or check all bolts | Monthly | | | | |
| Check for Unusual Noise and Vibration | Daily | | | | |
| Inspect for Air Leaks | Monthly | | | | |

GENERAL

The maintenance section of this book covers only those operations with which maintenance personnel may not be too familiar. It is expected that the average mechanic's training and experience will permit him to perform the more common maintenance functions without the need for detailed instructions.

AIR VALVE CLEANING

To remove and clean a concentric ring valve, observe the following step-by-step procedure:

1. Refer to Figure 6-1. If the air heads are equipped with unloaders, disconnect the tubing to the unloaders, remove the unloader capscrews and lift the unloaders off the air head.
2. Loosen the valve acorn nuts as shown in Figure 6-1, then take out the air head capscrews and remove the air head from the cylinder.
3. The valve itself may now be disassembled. To facilitate the valve disassembly, screw two bolts part way into the two threaded ports located in the valve seat. Clamp these bolts firmly in a vise and remove the locknut and hex nut. Note the manner in which the valve parts are assembled and replace them in the same order and position.

NOTE: Handle the valve parts with care. Do not nick, scratch or bend them.

4. The valve parts may be cleaned by light scraping or stiff brushing (do not use a wire brush.) If necessary, use a non-flammable safety solvent to loosen dirt, oil or carbon deposits.
5. Reassemble the valve parts in their proper sequence and position. Make absolutely certain that the stop-plate is centered properly on its guide; otherwise, the valve will be damaged when it is pulled up tight in the air head. Replace the valve hex nut and washer on the valve bolt. Tighten the valve hex nuts to the following torque:
 High pressure valve assembly - 60 to 70 ft. lbs.
 (8.30 to 9.68 kg/m)
 Low pressure valve assembly - 100 to 120 ft. lbs.
 (13.80 to 16.60 kg/m)

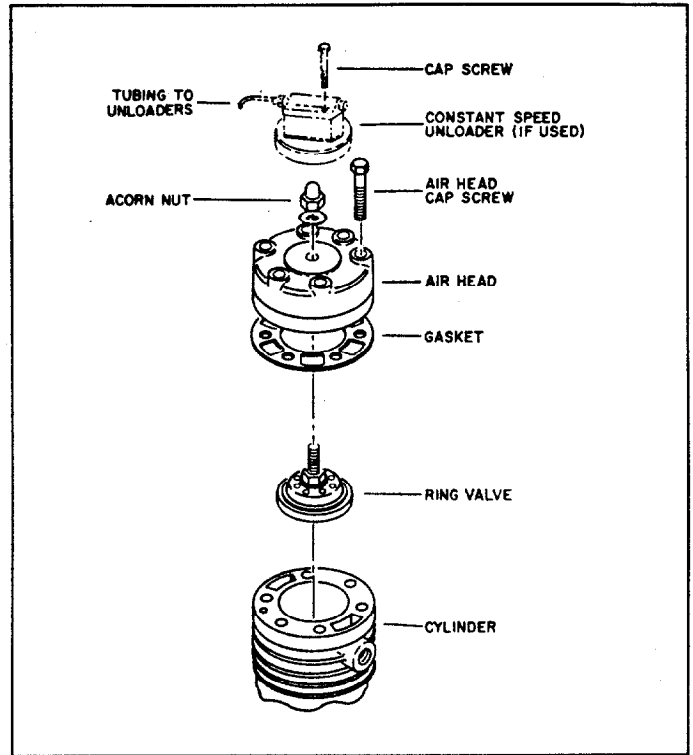

Figure 6-1. Concentric ring valve and air head assembly.

6. Before replacing the valve in the air head, scrape the old shellac off the valve bolt steel washer and coat it with new shellac to prevent air from leaking under the washer. Replace the acorn nut and tighten it to the lower limit of the torque value, recommended below. Do not over tighten this nut, since this will distort the springs and plates, causing the valve to leak. After the valve has been replaced in the air head, make certain that the valve operates freely by lifting at its edges with a knife blade.
7. Replace the air head gasket on the cylinder; then replace the air head. Tighten the air head capscrews to the torque recommended below and replace the unloader if the unit is so equipped.

TORQUE VALUES

We recommend the use of a torque wrench on all bolts, capscrews, and nuts using the values in the following table. The values given are for threads lubricated with oil or grease.

TORQUE VALUE TABLE

| NATIONAL COARSE | | GRADE 2 | | GRADE 5 | | GRADE 8 | |
|-----------------|------------|----------|-----------|----------|-----------|----------|-----------|
| Dia. | Pitch | Ft. Lbs. | Kg-Meters | Ft. Lbs. | Kg-Meters | Ft. Lbs. | Kg-Meters |
| | 1/4" — 20 | 4 | .55 | 6 | .82 | 9 | 1.24 |
| | 5/16" — 18 | 8 | 1.10 | 12 | 1.66 | 18 | 2.49 |
| | 3/8" — 16 | 15 | 2.10 | 23 | 3.18 | 31 | 4.29 |
| | 7/16" — 14 | 24 | 3.32 | 36 | 4.98 | 51 | 7.05 |
| | 1/2" — 13 | 37 | 5.12 | 56 | 7.74 | 80 | 11.06 |
| | 9/16" — 12 | 53 | 7.33 | 81 | 11.20 | 116 | 16.04 |
| | 5/8" — 11 | 68 | 9.40 | 113 | 15.63 | 160 | 22.12 |
| | 3/4" — 10 | 131 | 18.12 | 203 | 28.07 | 286 | 39.55 |

To determine the grade of the bolt or capscrew being tightened, use the following information.

Grade 2: No markings or vendor identification on the head.

Grade 5: Letter "S" or 3 lines and/or vendor identification on the head.

Grade 8: Letter "V" or 6 lines and/or vendor identification on the head.

BELT INSTALLATION AND ADJUSTMENT

When installing new belts, do not pry the belts over the pulley grooves. The proper method of removing and installing new belts is to loosen the anchor screws and the belt tightener screw, Figure 6-2, and push the motor toward the compressor. Use the tightener screw to adjust belt tension on new belts.

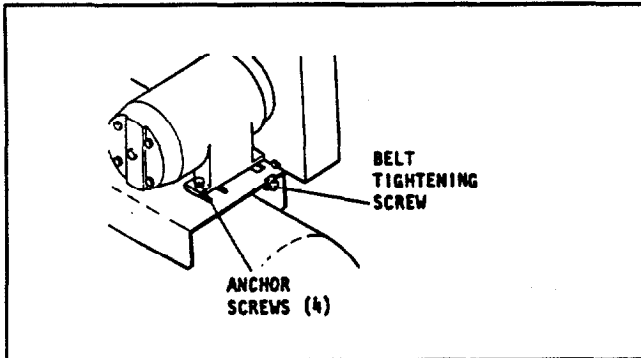

Figure 6-2. Belt Adjustments.

NOTE: The belts must be a matched set to permit equal load distribution.

It is important that the belts be properly adjusted. A belt that is too loose will slip and cause heating and wear, and a belt that is too tight may overload the bearings. A quick check to determine if belt adjustment is proper may be made by observing the slack side of the belt for a slight bow when the unit is in operation. See Figure 6-3. If a slight bow is evident, belts are usually adjusted satisfactorily. However, the recommended method of checking belt tension is by the more accurate spring scale measurement method that follows:

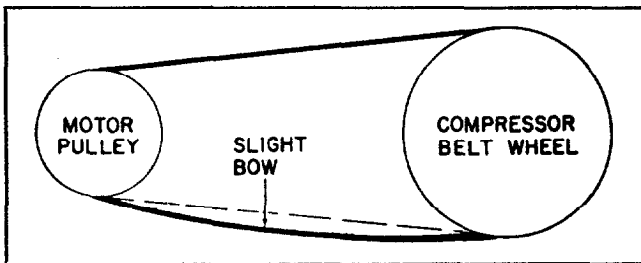

Figure 6-3. Visual Method.

A. Measure the belt span (t) as shown in Figure 6-4.

B. At the center of the span (t), apply a force (perpendicular to the span) by attaching a spring scale to the two outside belts. The force applied to the spring scale should be sufficient to deflect the belts $1/64$ " (.396 mm) for every inch of span length (t). For example, The deflection of 100" (2540 mm) span would be $100/64$ " or $1\ 9/16$ " (39.6 mm), thus, the force applied to the spring scale should deflect the belts to $1\ 9/16$ " (39.6 mm).

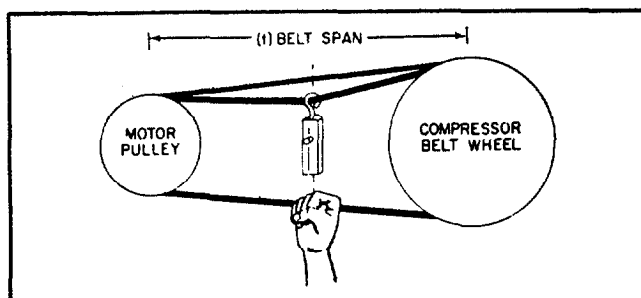

Figure 6-4. Spring Scale Method.

C. When the belts are deflected the necessary distance, compare the spring scale reading (in lbs. force) with the value given in the following table.

STANDARD BELTS

| Belt Type | Normal Tension | 150% Normal Tension |
|-----------|----------------------|---------------------|
| A | 1 1/4 lbs. (.565 kg) | 1 7/8 lbs. (.85 kg) |
| B | 2 3/4 lbs. (1.25 kg) | 4 lbs. (1.81 kg) |

If the reading is between the value for normal tension and 150% normal tension, the belt tension should be satisfactory. A reading below the value for normal tension indicates the belt slack should be reduced, and conversely, a reading exceeding the value for 150% normal tension indicates the belt slack should be increased. Experienced has shown that a new drive can be tightened initially to two times normal tension to allow for any drop in tension during run in.

SECTION VII

OPTIONAL EQUIPMENT

ACCESSORIES AND PIPING ARRANGEMENTS

AFTERCOOLERS

Two types of aftercoolers are used; air-cooled and water-cooled. The purpose of an aftercooler is to reduce the discharge temperature of the compressed air and to facilitate removal of water vapor and oil vapor.

AIR-COOLED AFTERCOOLER

The cooler consists of finned tubing through which compressed air passes on its way to the air receiver. Cooling air drawn over these tubes by the fan-type flywheel cools the compressed air and condenses moisture. This moisture passes on to the receiver and is drained either manually or by an automatic drain trap.

This type aftercooler also acts as a belt guard.

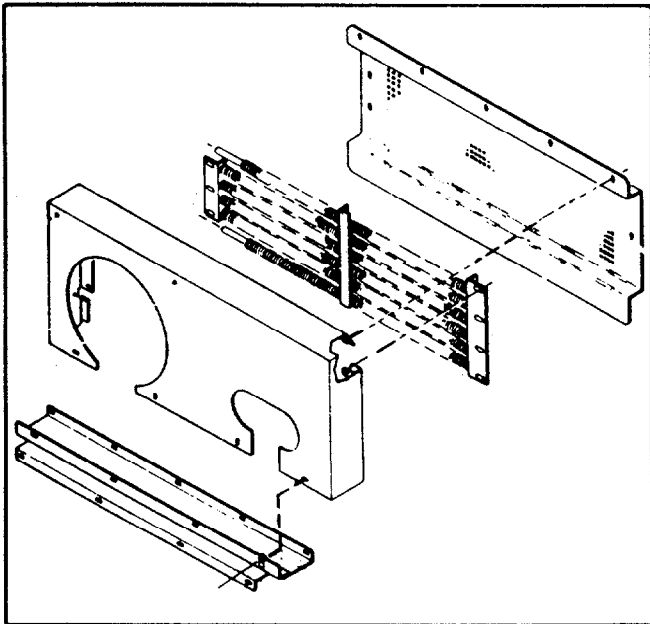

Figure 7-1. Typical Air-Cooled Aftercooler with Belt Guard, (Disassembled).

SERVICING - The air-cooled aftercooler will require very little maintenance. The tubes should be blown clean with compressed air weekly.

WATER-COOLED AFTERCOOLER

The model S-5 or S-6 water-cooled aftercooler may be furnished with your compressor if requested. The air and water inlet and outlet locations are shown in Figure 7-2.

The cooler consists of multi tubes, supported in a shell by internal baffles and headers on each end. The tubes, shell, baffles, and headers are all made of copper and brazed together. The internal baffles divert the water flow for better heat transfer.

Mount the aftercooler as close to the air receiver as possible, using pipe of the same diameter as the compressor discharge port, if the total length is less than 10 feet (3.04 m). If the total length is more than 10 feet (3.04 m), use the next larger diameter size pipe. The aftercooler must be adequately supported.

Air piping from the compressor discharge to the aftercooler should be sloped in such a manner to prevent the condensate from draining into the compressor, but if overhead piping is used, a

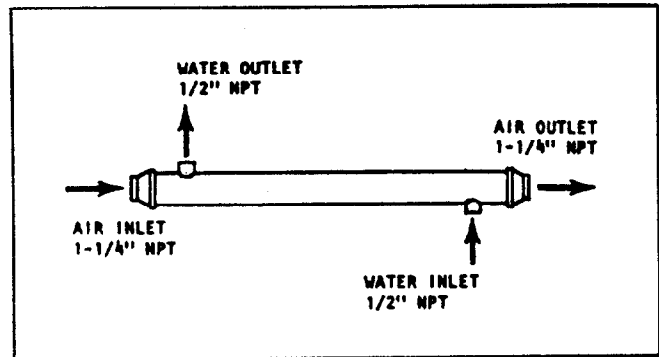

Figure 7-2. Typical water-cooled aftercooler.

drain leg, to trap condensed moisture, should be mounted next to the compressor. (See Figure 2-3.)

An automatic water shut-off valve is available as optional equipment for controlling the flow of water through the aftercooler in synchronization with the operation of the compressor. This valve is always used in conjunction with a manually operated valve for regulating the rate of water flow. The water flow should be adjusted to allow a maximum discharge water temperature of 120° F.

If an automatic water valve is not used, merely install a hand operated valve in the water inlet line.

SERVICING — The water-cooled aftercooler is designed as an efficient but economical throw away type cooler which may be cleaned if desired.

To maintain this cooler, periodically blow compressed air thru each individual tube until they are clean and free of any foreign obstructions.

To clean the water side of the cooler, use a hot water and cleaner solution or a non-flammable chemical flush. Back flush several times until all foreign matters has been dispelled. If calcium build up or other foreign matter is still evident, disposing of the cooler and purchase of a new one is recommended.

AUTOMATIC WATER VALVE

The automatic water valve is furnished only when specified, and it is to be installed in the water inlet line ahead of the aftercooler. Always install a hand valve in the line to control the rate of water flowing through the aftercooler.

The automatic water valve stops the flow of water through the water-cooler aftercooler when the compressor stops or operates unloaded. The operation of the water valve is controlled by air pressure from the compressor intercooler.

When the compressor starts or loads, intercooler air pressure against diaphragm "B" (See Figure 7-3) overcomes the pressure of spring "D". Valve "C" now opens, permitting water to flow through the water valve and the aftercooler. When the compressor stops or unloads, the pressure is removed from the intercooler. Valve "C" now closes, shutting off the water flow.

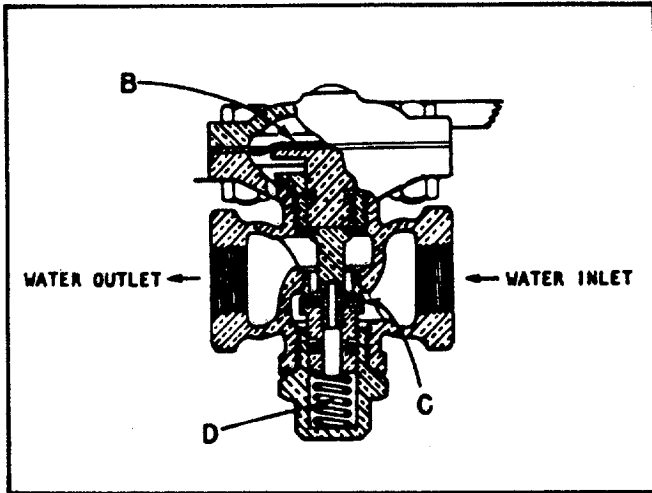

Figure 7-3. Automatic Water Shutoff Valve.

AUTOMATIC DRAIN TRAP

When specified on the purchase order, units are provided with an automatic condensate drain trap. The purpose of the drain trap is to expel the condensate from the receiver and/or the aftercooler.

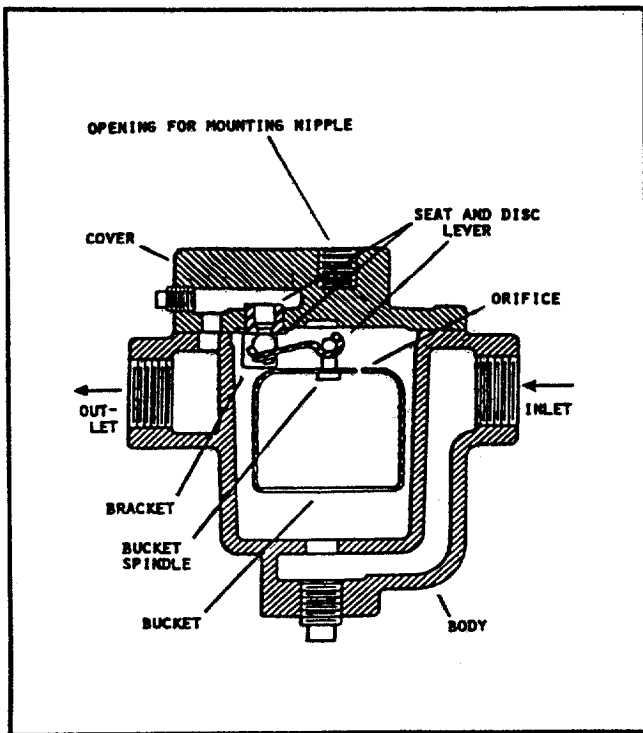



Figure 7-4. Inverted-Bucket, Automatic Condensate Drain Trap.

WARNING



This machine contains high pressure air which can cause injury or death from flying parts.

Always release pressure from compressor and air receiver before removing caps, plugs, fittings, covers, priming condensate trap: etc.

TO PRIME CONDENSATE TRAP: (See Figure 7-5). Close manual shut-off valve installed in bottom side of pipe tee. Remove

pipe plug installed in top of pipe tee, and pour water into top opening of pipe tee until trap and pipe tee are filled with water. Open manual shut-off valve releasing water in pipe tee into air receiver. Re-install pipe plug using pipe thread lubricant and tighten to prevent air leak.

When the inverted-bucket-style, automatic condensate drain trap is properly primed, and as pressure is built up in the air receiver, condensate is forced into the trap and out the trap outlet. However, if the trap is not properly primed, the inverted bucket remains in its down position. This causes the valve to remain open, allowing air pressure leakage to atmosphere.

Where there is little or no condensate present in the air receiver, the trap will continue to expel a small amount of air pressure each time the inverted bucket loses buoyancy. The amount of air pressure lost by the cycling of the inverted bucket is negligible; however, it may present the appearance of a faulty automatic condensate drain trap if this cycling is not properly understood. It is very important to understand that this small amount of intermittent air leakage is perfectly normal and should not give cause for alarm. However, if air leakage occurs on a continuous basis, it could be an indication the trap has lost its prime or that the trap may be faulty.

TO PREVENT REPRIMING TRAP, CLOSE MANUAL SHUT-OFF VALVE ON TRAP BEFORE COMPLETE AIR LOSS OF RECEIVER.

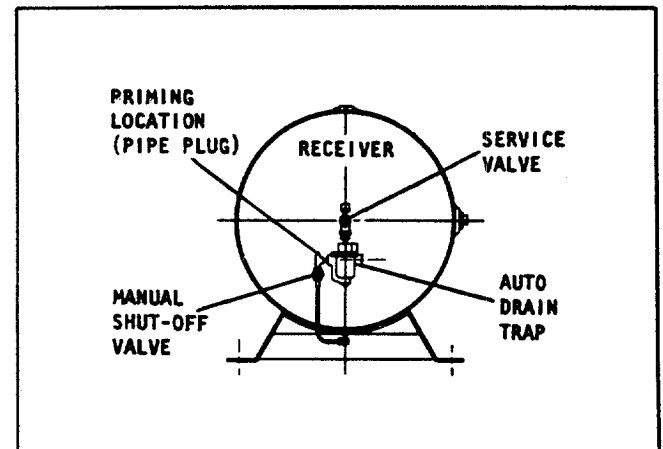



Figure 7-5. Auto Drain Trap priming location.

AIR RECEIVER

If the air system into which the compressor discharges does not have sufficient volume, the compressor will cycle too frequently. In this case, an air receiver must be used to provide enough volume to operate the regulation system of the compressor.

WARNING



This machine contains high pressure air which can cause injury or death from flying parts.

Never operate the compressor above the maximum working pressure of the air receiver.

Air receivers must meet the safety requirement of the state in which they are used.

THE AIR RECEIVER IS MANUFACTURED TO MEET THE REQUIREMENTS OF THE ASME BOILER AND PRESSURE VESSEL CODE.

SECTION VIII
MODEL 5T2NL PARTS LIST

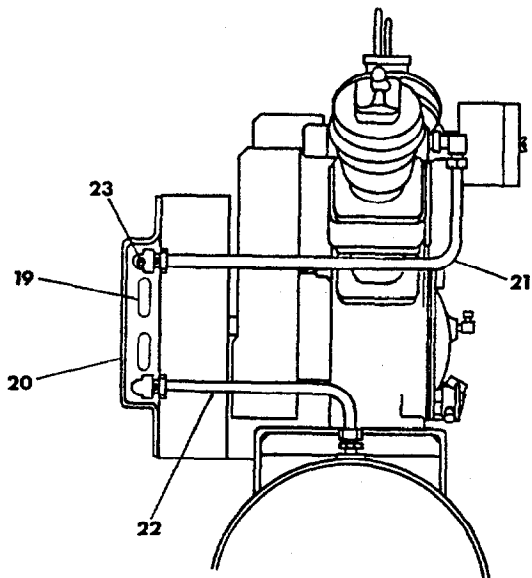
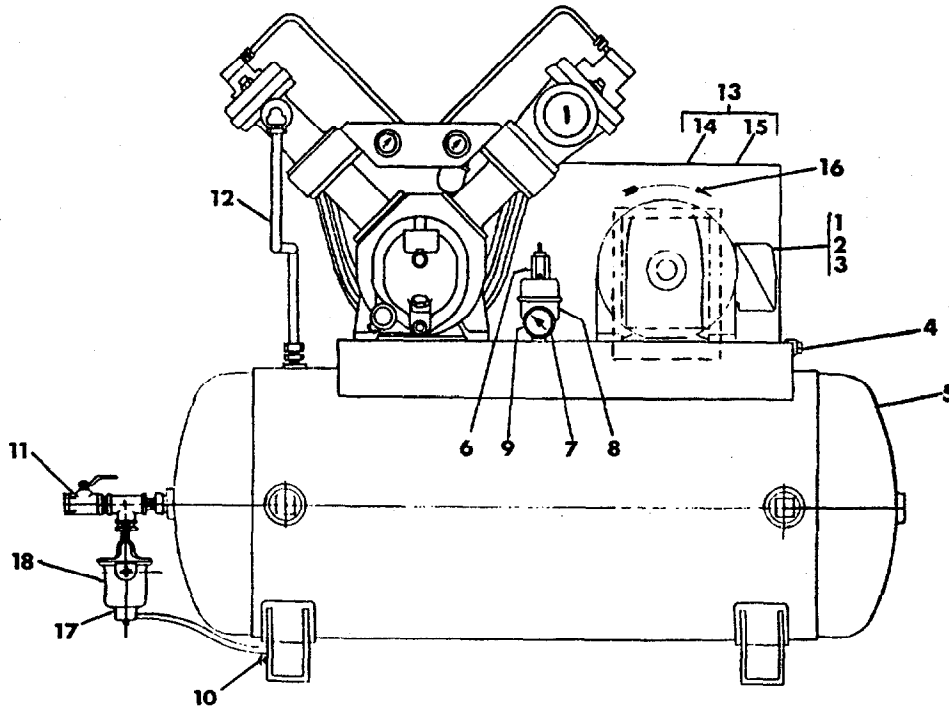

**DETAIL A - AIR COOLED
AFTERCOOLER**

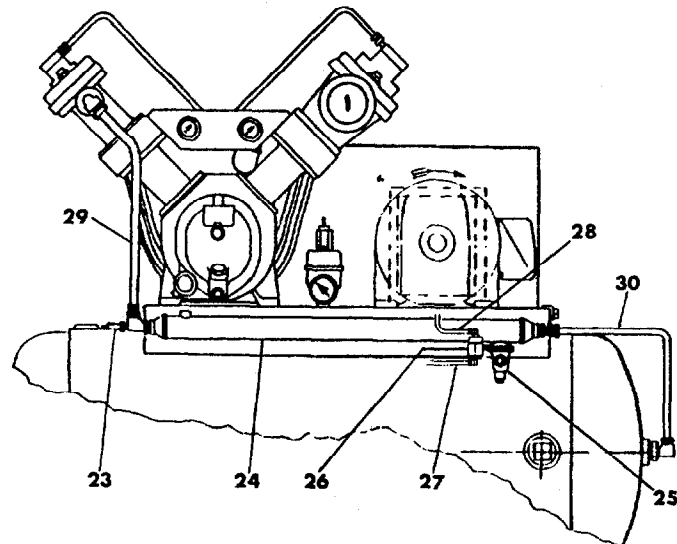

DETAIL B - WATER COOLED AFTERCOOLER

FIGURE 8-1. COMPRESSOR DRIVE, AIR RECEIVER, AND ACCESSORIES.

MODEL 5T2NL PARTS LIST

| REF. NBR. | PART NUMBER | DESCRIPTION | UNITS PER ASSY. | REC. SPARES | | |
|-----------|-------------|---------------------------------------|-----------------|-------------|---|---|
| | | | | 1 | 2 | 3 |
| 11-1 | | MOTOR † | 1 | | | |
| 11-2 | | PULLEY, MOTOR† | 1 | | | |
| 11-3 | | BELT, V † | 3 | | 3 | 3 |
| 11-4 | 32182255 | TIGHTENER, BELT—COMPLETE—5 H.P. STD. | 1 | | | |
| 11-4 | 32182248 | TIGHTENER, BELT—COMPLETE—7½ H.P. STD. | 1 | | | |
| 11-5 | 32162349 | RECEIVER ASSEMBLY 80 GAL. HORIZONTAL | 1 | | | |
| 11-6 | 32169997 | VALVE, AUXILIARY—CONSTANT SPEED | 1 | | | 1 |
| 11-6 | 32151722 | VALVE, AUXILIARY—DUAL CONTROL | 1 | | | 1 |
| 11-7 | 32013872 | GAUGE, PRESSURE | 1 | 1 | 1 | 1 |
| 11-8 | 37005907 | SWITCH, PRESSURE—STANDARD | 1 | 1 | 1 | 1 |
| 11-9 | 72061971 | VALVE, SAFETY—RECEIVER | 1 | | 1 | 1 |
| 11-10 | 32027120 | VALVE, DRAIN—MANUAL | 1 | | | |
| 11-11 | 32180234 | VALVE, BALL—SERVICE | 1 | | | |
| 11-12 | 32058513 | TUBE ASSEMBLY—COMPRESSOR/RECEIVER | 1 | | | |
| 11-13 | 32002586 | BELT GUARD—COMPLETE | 1 | | | |
| 11-14 | 32003394 | ● BACK, BELT GUARD | 1 | | | |
| 11-15 | 32003287 | ● COVER, BELT GUARD | 1 | | | |
| 11-16 | 30286686 | DECAL, ROTATION ARROW | 1 | | | |
| | | OPTIONAL EQUIPMENT | | | | |
| 11-17 | 32005282 | TRAP, AUTO DRAIN | 1 | | | |
| 11-18 | 32180200 | VALVE, BALL—1/4" | 1 | | | 1 |
| | | DETAIL A | | | | |
| 11-19 | 32003212 | COIL, AFTERCOOLER | 1 | | | 1 |
| 11-20 | 32003279 | COVER, AIRCOOLED AFTERCOOLER | 1 | | | |
| 11-21 | 32058521 | TUBE ASSEMBLY—COMPRESSOR/ACAC. | 1 | | | |
| 11-22 | 32058539 | TUBE ASSEMBLY, ACAC/RECEIVER | 1 | | | |
| 11-23 | 31385693 | VALVE, SAFETY—DISCHARGE | 1 | | 1 | 1 |
| | | DETAIL B | | | | |
| 11-24 | 32144404 | AFTERCOOLER, WATER COOLED | 1 | | | |
| 11-25 | 35229723 | VALVE, WATER | 1 | | | |
| 11-26 | 30220651 | VALVE, REVERSING | 1 | | | |
| 11-27 | 32146540 | TUBE ASSEMBLY, REV. VALVE/HEAD | 1 | | | |
| 11-28 | 32146557 | TUBE ASSEMBLY, REV. VALVE/INTRCL. | 1 | | | |
| 11-29 | 32146508 | TUBE ASSEMBLY, COMPR./WCAC | 1 | | | |
| 11-30 | 32146516 | TUBE ASSEMBLY, WCAC/RECVR. | 1 | | | |

† SPECIFY DISCHARGE PRESSURE OF COMPRESSOR AND COMPLETE MOTOR NAMEPLATE DATA.

STEP SAVER KIT

For your convenience, the following parts and/or spare parts for your compressor are available in parts kits. When ordering the kits below, use kit names as Description and the Part No. as shown.

| PART NO. | DESCRIPTION |
|----------|-----------------------------|
| 32166787 | KIT, FILTER |
| 32132912 | KIT, VALVE/GASKET |
| 32132920 | KIT, RING/GASKET |
| 32132938 | KIT, BEARING/CONNECTING ROD |
| 37126711 | KIT, GASKET |

MODEL 10T3NL PARTS LIST

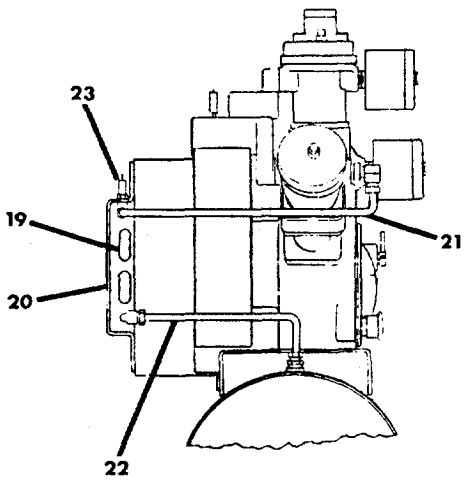
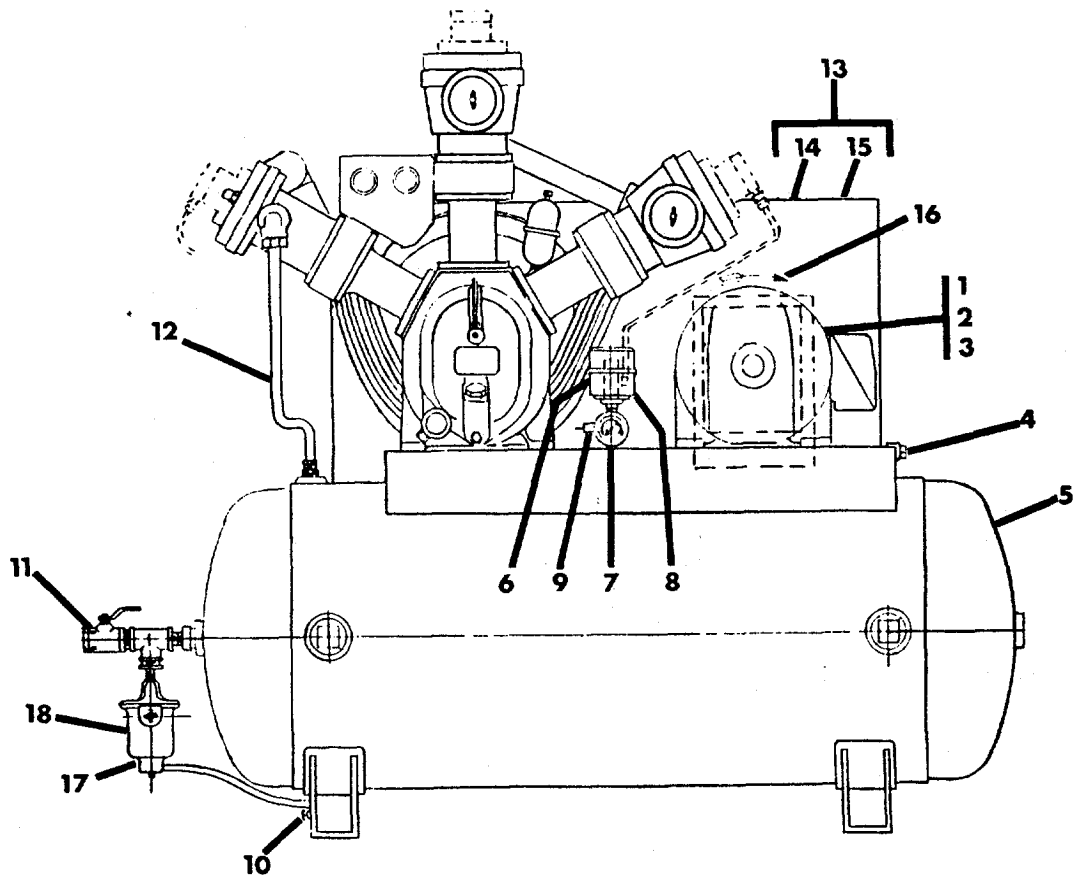

**DETAIL A - AIR COOLED
AFTERCOOLER**

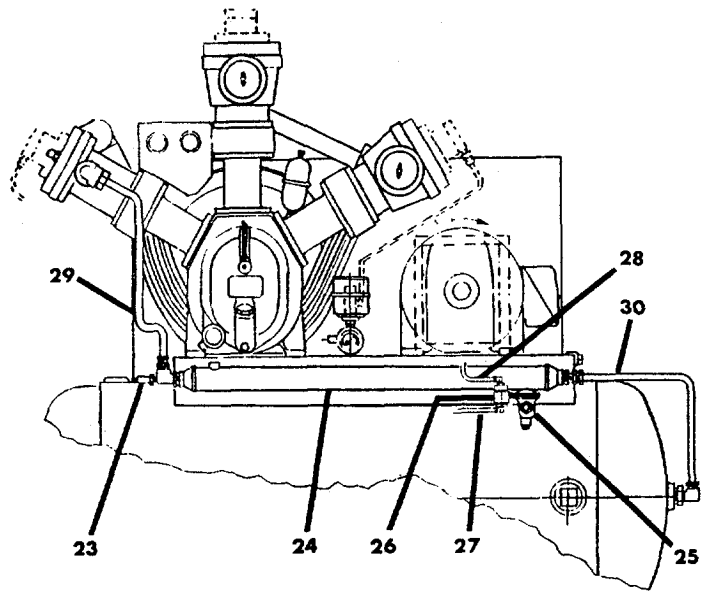

DETAIL B - WATER COOLED AFTERCOOLER

FIGURE 8-2. COMPRESSOR DRIVE, AIR RECEIVER, AND ACCESSORIES.

MODEL 10T3NL PARTS LIST

| REF. NBR. | PART NUMBER | DESCRIPTION | UNITS PER ASSY. | REC. SPARES | | |
|-----------|-------------|---|-----------------|-------------|---|---|
| | | | | 1 | 2 | 3 |
| 11-1 | | MOTOR † | 1 | | | |
| 11-2 | | PULLEY, MOTOR † | 1 | | | |
| 11-3 | | BELT, V † | 3 | | 3 | 3 |
| 11-4 | 32188690 | TIGHTENER, BELT—COMPLETE—10 H.P. STD. | 1 | | | |
| 11-4 | 32188708 | TIGHTENER, BELT—COMPLETE—15 H.P. STD. | 1 | | | |
| 11-5 | 32162406 | RECEIVER ASSEMBLY 120 GAL. HORIZONTAL | 1 | | | |
| 11-6 | 32169997 | VALVE, AUXILIARY CONSTANT SPEED | 1 | | | 1 |
| 11-6 | 32151722 | VALVE, AUXILIARY DUAL CONTROL | 1 | | | 1 |
| 11-7 | 32013872 | GAUGE, PRESSURE | 1 | 1 | 1 | 1 |
| 11-8 | 37005907 | SWITCH, PRESSURE—STANDARD | 1 | 1 | 1 | 1 |
| 11-9 | 72061971 | VALVE, SAFETY—RECEIVER | 1 | | 1 | 1 |
| 11-10 | 32027120 | VALVE, DRAIN—MANUAL | 1 | | | |
| 11-11 | 32180242 | VALVE, BALL—SERVICE | 1 | | | |
| 11-12 | 32117970 | TUBE ASSEMBLY—COMPRESSOR/RECEIVER | 1 | | | |
| 11-13 | 32002594 | BELT GUARD—COMPLETE | 1 | | | |
| 11-14 | 32003378 | ● BACK, BELT GUARD | 1 | | | |
| 11-15 | 37154812 | ● COVER, BELT GUARD | 1 | | | |
| 11-16 | 30286686 | DECAL, ROTATION ARROW | 1 | | | |
| | | OPTIONAL EQUIPMENT | | | | |
| 11-17 | 32005282 | TRAP, AUTO DRAIN | 1 | | | |
| 11-18 | 32180200 | VALVE, BALL—1/4" | 1 | | | 1 |
| | | DETAIL A | | | | |
| 11-19 | 32003220 | COIL, AFTERCOOLER | 1 | | | 1 |
| 11-20 | 32003246 | COVER, AIRCOOLED AFTERCOOLER | 1 | | | |
| 11-21 | 32118069 | TUBE ASSEMBLY, COMPRESSOR/ACAC. | 1 | | | |
| 11-22 | 32118077 | TUBE ASSEMBLY, ACAC/RECEIVER | 1 | | | |
| 11-23 | 32174286 | VALVE, SAFETY—DISCHARGE | 1 | | 1 | 1 |
| | | DETAIL B | | | | |
| 11-24 | 32144412 | AFTERCOOLER, WATER COOLED | 1 | | | |
| 11-25 | 35229723 | VALVE, WATER | 1 | | | |
| 11-26 | 30220651 | VALVE, REVERSING | 1 | | | |
| 11-27 | 32146581 | TUBE ASSEMBLY, REV. VALVE/HEAD | 1 | | | |
| 11-28 | 32146599 | TUBE ASSEMBLY, REV. VALVE/INTRCL. | 1 | | | |
| 11-29 | 32146565 | TUBE ASSEMBLY, COMPR./WCAC | 1 | | | |
| 11-30 | 32146433 | TUBE ASSEMBLY, WCAC/RECVR. | 1 | | | |
| | | † SPECIFY DISCHARGE PRESSURE OF COMPRESSOR AND COMPLETE MOTOR NAMEPLATE DATA. | | | | |

STEP SAVER KIT

For your convenience, the following parts and/or spare parts for your compressor are available in parts kits. When ordering the kits below, use kit names as Description and the Part No. as shown.

| PART NO. | DESCRIPTION |
|----------|-----------------------------|
| 32127482 | KIT, FILTER |
| 32132953 | KIT, VALVE/GASKET |
| 32132961 | KIT, RING/GASKET |
| 32132979 | KIT, BEARING/CONNECTING ROD |
| 37126729 | KIT, GASKET |

SECTION IX

TYPICAL WIRING DIAGRAM

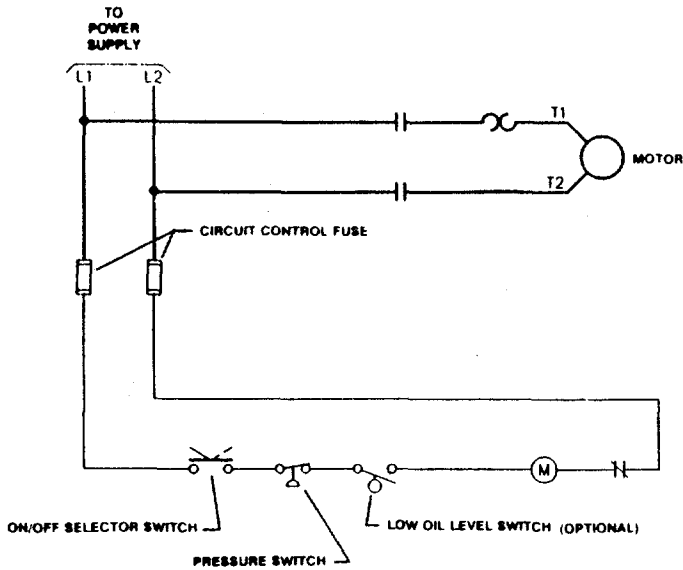

DEFINITE PURPOSE MOTOR STARTER

SINGLE PHASE MOTOR

NOTES:

1. L1, L2, - INDICATES POWER SUPPLY LINE TERMINALS.
2. T1, T2, - INDICATES LOAD TERMINALS.
3. M - INDICATES MAGNETIC STARTER COIL.
4. (OPTIONAL) - INDICATES ACCESSORY ITEM THAT MAY NOT BE SUPPLIED ON YOUR PARTICULAR MODEL.
5. CIRCUIT SHOWN IN NORMAL POSITION DE-ENERGIZED AND WITH COMPRESSOR CRANKCASE EMPTY OF OIL.
6. ALL WIRING TO BE IN ACCORDANCE WITH NATIONAL ELECTRIC CODE. CHECK FOR ADDITIONAL LOCAL AND STATE REGULATIONS AND CODES.
7. PRESSURE SWITCH NOT SUPPLIED ON CONSTANT SPEED CONTROL MODEL.

TYPICAL WIRING DIAGRAM

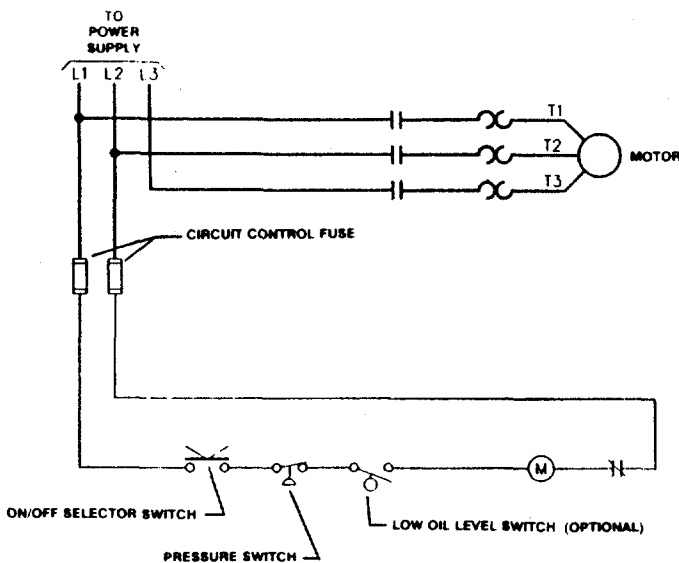

DEFINITE PURPOSE MOTOR STARTER

THREE PHASE MOTOR

NOTES:

1. L1, L2, L3, - INDICATES POWER SUPPLY LINE TERMINALS.
2. T1, T2, T3, - INDICATES LOAD TERMINALS.
3. M - INDICATES MAGNETIC STARTER COIL.
4. (OPTIONAL) - INDICATES ACCESSORY ITEM THAT MAY NOT BE SUPPLIED ON YOUR PARTICULAR MODEL.
5. CIRCUIT SHOWN IN NORMAL POSITION DE-ENERGIZED AND WITH COMPRESSOR CRANKCASE EMPTY OF OIL.
6. ALL WIRING TO BE IN ACCORDANCE WITH NATIONAL ELECTRIC CODE. CHECK FOR ADDITIONAL LOCAL AND STATE REGULATIONS AND CODES.
7. PRESSURE SWITCH NOT SUPPLIED ON CONSTANT SPEED CONTROL MODEL.

TYPICAL WIRING DIAGRAM

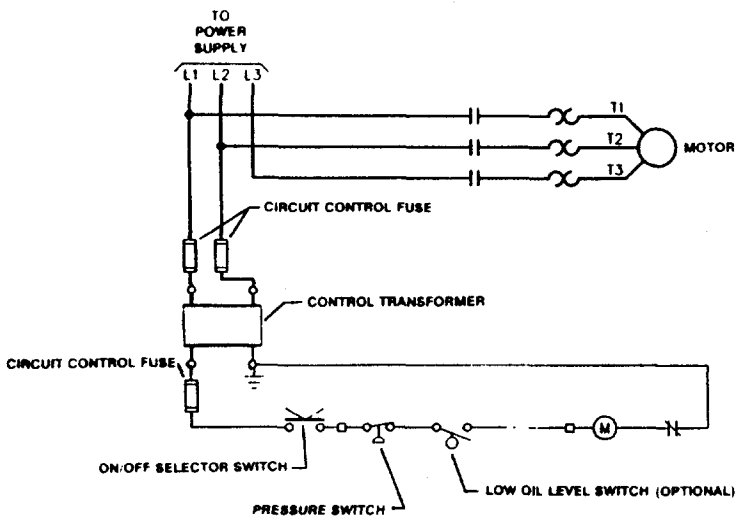

STANDARD NEMA MOTOR STARTER

THREE PHASE MOTOR

NOTES:

1. L1, L2, L3, - INDICATES POWER SUPPLY LINE TERMINALS.
2. T1, T2, T3, - INDICATES LOAD TERMINALS.
3. M - INDICATES MAGNETIC STARTER COIL.
4. (OPTIONAL) - INDICATES ACCESSORY ITEM THAT MAY NOT BE SUPPLIED ON YOUR PARTICULAR MODEL.
5. CIRCUIT SHOWN IN NORMAL POSITION DE-ENERGIZED AND WITH COMPRESSOR CRANKCASE EMPTY OF OIL.
6. ALL WIRING TO BE IN ACCORDANCE WITH NATIONAL ELECTRIC CODE. CHECK FOR ADDITIONAL LOCAL AND STATE REGULATIONS AND CODES.
7. PRESSURE SWITCH NOT SUPPLIED ON CONSTANT SPEED CONTROL MODEL.

TYPICAL WIRING DIAGRAM

NON-COMBINATION ALTERNATOR PANEL

THREE PHASE MOTOR

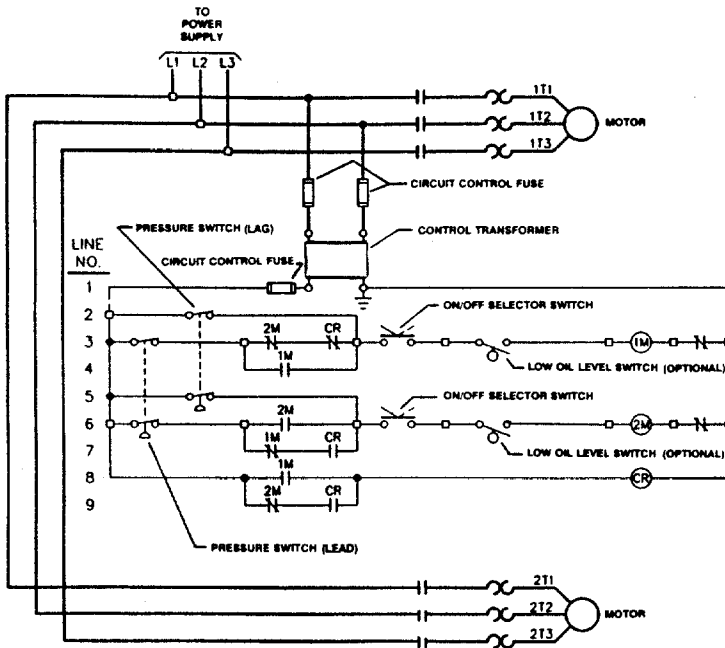

NOTES:

1. L1, L2, L3, - INDICATES POWER SUPPLY LINE TERMINALS.
2. T1, T2, T3, - INDICATES LOAD TERMINALS.
3. M - INDICATES MAGNETIC STARTER COIL.
4. CR - INDICATES CONTROL RELAY.
5. (OPTIONAL) - INDICATES ACCESSORY ITEM THAT MAY NOT BE SUPPLIED ON YOUR PARTICULAR MODEL.
6. CIRCUIT SHOWN IN NORMAL POSITION DE-ENERGIZED AND WITH COMPRESSOR CRANKCASE EMPTY OF OIL.
7. ALL WIRING TO BE IN ACCORDANCE WITH NATIONAL ELECTRIC CODE. CHECK FOR ADDITIONAL LOCAL AND STATE REGULATIONS AND CODES.
8. (LAG) PRESSURE SWITCH TO HAVE LOWER PRESSURE SETTING THAN (LEAD) PRESSURE SWITCH.

TYPICAL WIRING DIAGRAM

COMBINATION ALTERNATOR PANEL

THREE PHASE MOTOR

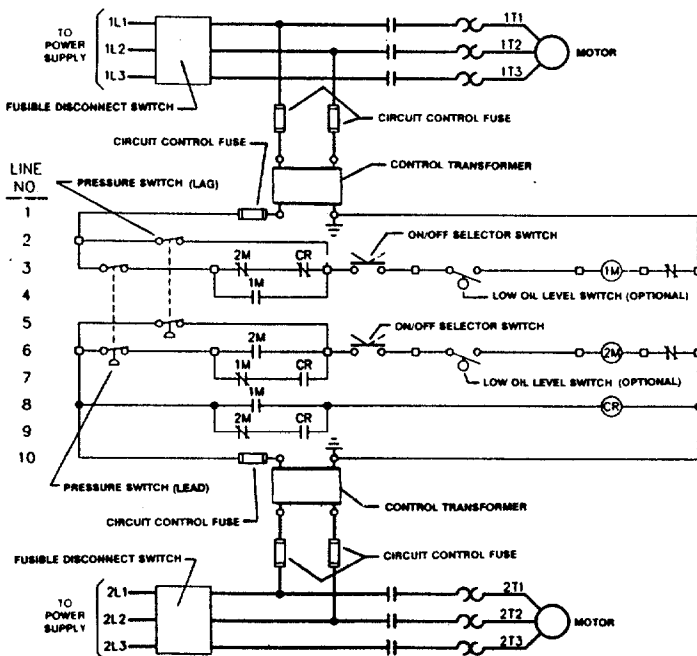

NOTES:

1. L1, L2, L3, - INDICATES POWER SUPPLY LINE TERMINALS.
2. T1, T2, T3, - INDICATES LOAD TERMINALS.
3. M - INDICATES MAGNETIC STARTER COIL.
4. CR - INDICATES CONTROL RELAY.
5. (OPTIONAL) - INDICATES ACCESSORY ITEM THAT MAY NOT BE SUPPLIED ON YOUR PARTICULAR MODEL.
6. CIRCUIT SHOWN IN NORMAL POSITION DE-ENERGIZED AND WITH COMPRESSOR CRANKCASE EMPTY OF OIL.
7. ALL WIRING TO BE IN ACCORDANCE WITH NATIONAL ELECTRIC CODE. CHECK FOR ADDITIONAL LOCAL AND STATE REGULATIONS AND CODES.
8. (LAG) PRESSURE SWITCH TO HAVE LOWER PRESSURE SETTING THAN (LEAD) PRESSURE SWITCH.

NOTICE

THE USE OF REPAIR PARTS OTHER THAN THOSE INCLUDED WITHIN THE INGERSOLL-RAND COMPANY APPROVED PARTS LIST MAY CREATE UNSAFE CONDITIONS OR MECHANICAL FAILURES OVER WHICH INGERSOLL-RAND COMPANY HAS NO CONTROL. INGERSOLL-RAND COMPANY SHALL BEAR NO RESPONSIBILITY FOR EQUIPMENT ON WHICH NON-APPROVED REPAIRS PARTS ARE INSTALLED.

The manufacturer reserves the right to make changes or add improvements without notice and without incurring any obligation to make such changes or add such improvements to products previously sold.

GLOSSARY

GROUP ASSEMBLY PARTS LIST

Parts are listed in disassembly sequence, where applicable. Each assembly is broken down into subassemblies and detail parts, which are indented with "bullet" (•) symbols in the DESCRIPTION column to indicate the relationship to the next higher assembly. For example:

Assemblies and Detail Parts

- Attaching Parts for Assemblies and Detail Parts
 - Subassemblies
 - Attaching Parts of Subassemblies
 - • • Detail Parts for Subassemblies, etc.

REFERENCE NUMBER COLUMN

The reference number is the number assigned to the part in the listing. The reference number corresponds to the item on the associated illustration. Where applicable, the following abbreviations might in this column:

- NI Not Illustrated
- REF Reference Only. Refer to the Figure and Page noted in the DESCRIPTION column.

PART NUMBER COLUMN

All numbers listed in this column are Ingersoll-Rand part numbers, and must be specified when ordering replacement parts. The following abbreviations appear in this column:

- NA Not Applicable. This abbreviation indicates items which are not used on particular models or packages.
- NSS Not Sold Separately. These items must be ordered under the next higher assembly; or, where applicable, as part of a step saver kit.
- * Consumable Materials (lubricants, sealants, etc.). Purchase directly from local Ingersoll-Rand Air Center or Full Service Distributor.
- ** Part Number Varies. Specify the compressor bare speed and complete nameplate data when ordering.

DESCRIPTION COLUMN

The description column identifies the item by standard name followed by modifiers. The modifiers identify specific characteristics (i.e. dimensions, capacity, pressure setting, etc.), and/or the particular location or function on the compressor. Always include the description when ordering replacement parts or kits.

QUANTITY PER ASSEMBLY COLUMN

Quantities listed in this column reflect the number used in the next higher assembly, and are not necessarily the total quantity of the part used in the complete package. Specify the desired quantity when ordering replacement parts.

HOW TO SELECT RECOMMENDED SPARES

Quantities listed in the RECOMMENDED SPARES column reflect the number of each item which we recommend be kept on hand for maintenance or repair. The appropriate quantity for your application will depend on how critical interruptions in service are to your operation. Recommended spares are divided into three classes:

- CLASS 1 MINIMUM. Recommended quantity for Domestic Service where interruptions in service are not important.
- CLASS 2 AVERAGE. Recommended quantity for Domestic Service where interruptions in continuity of service are not objectionable.
- CLASS 3 MAXIMUM. Recommended quantity for International or Domestic Service where interruptions in service are not acceptable.

STEP SAVER KITS

Step Saver Kits are available for all Type 30 compressor models. These kits are designed to provide all of the parts you will need to perform routine maintenance and repair tasks. A list of available Step Saver Kits is included in the Parts List manual which came with your compressor. When ordering Step Saver Kits, please follow the instructions set out below for ordering replacement parts.

ORDERING INSTRUCTIONS

All parts listed in the Part List manual for your compressor are available through your local Ingersoll-Rand Air Center or Full Service Distributor. Consult the Directory of Distributors included with your compressor to locate the distributor in your area.

HOW TO ORDER COMPRESSOR PARTS

- When ordering replacement parts or Step Saver Kits, please specify:
1. The MODEL and SERIAL NUMBER as stamped on the Compressor Nameplate.
 2. The FORM NUMBER of the Parts List Manual, as shown on the lower right-hand corner of the front cover.
 3. The QUANTITY, DESCRIPTION and PART NUMBER exactly as listed.

EXAMPLE

| | |
|------------------------------------|-----------|
| Send the following parts for Model | 7100 |
| Serial Number | T30000000 |
| Literature Form Number | SCD-478A |
| 1 Switch, Pressure - NEMA 1 | 37005907 |
| 1 Element, Filter | 32012957 |
| 1 Gauge, Pressure | 32013872 |

Look What INGERSOLL-RAND Can Do For YOU...

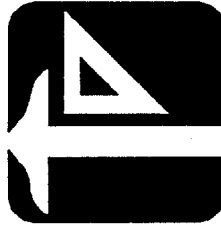

SPECIAL ENGINEERING SERVICE
We can help you to identify and solve your compressed air problems by evaluating your needs and recommending the proper compressor and air piping system to give you maximum efficiency.



EFFICIENT FIELD SERVICE
We maintain a highly trained staff of technicians to service your equipment for preventive maintenance, or to assist you should emergencies ever occur.



SPARE PARTS
By stocking genuine I-R spare parts, we can help you avoid costly delays, or substituting inferior parts. Using genuine I-R parts on your I-R equipment will help to keep even older machines running in good-as-new condition.

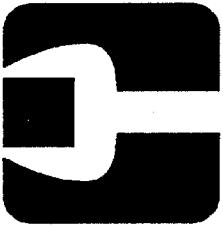

COMPLETE REPAIR SERVICE
Our trained technicians will repair or overhaul your equipment to factory specifications, using only genuine I-R parts.

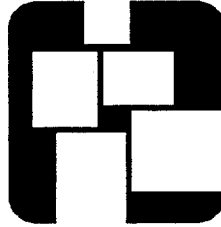

COMPLETE STOCK OF EQUIPMENT
We carry a complete line a I-R equipment and accessories designed to meet any compressed air application. We are backed by Ingersoll-Rand's prompt factory shipment to ensure you on-time delivery.

A SUBSTITUTE IS NOT A REPLACEMENT

Ensure you get peak performance and longevity out of your compressor by insisting on genuine Ingersoll-Rand replacement parts and maintenance kits. Not only are they made to precise dimensions and OEM-specified metalurgy, but each part is backed by the Ingersoll-Rand warranty. Your local Air Center, Full-Service Distributor or direct Ingersoll-Rand salesperson will work with you to ensure you get the parts you need to do the job right. Equip your machines with only the best -

INGERSOLL-RAND GENUINE PARTS.

DISTRIBUTED BY

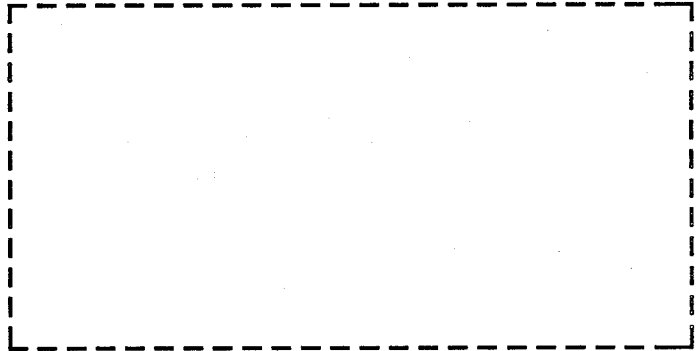

INGERSOLL-RAND COMPANY
Small Compressor Division
Campbellsville, KY 42718

© 1993 INGERSOLL-RAND COMPANY

Printed in the U.S.A.

APPENDIX H PUMPS

| OHM ID NUMBER | PUMP DESCRIPTION | SECTION |
|---------------------|---------------------------------|--------------------------------|
| P - 110 A,B | Air stripper feed pumps | 1 |
| P - 025, 025A | Sump pumps | 2 |
| P - 115 | Containment area sump pump | 2 |
| P - 120 | Jet mixing pump & system | 3 |
| P - 121 | Caustic feed pump | 4 |
| P - 143 | Sludge blowdown pump | 5 |
| P - 145 | Supernatant transfer pump | 1 |
| P - 205 | Spent backwash water pump | 6 |
| P - 211, 212 | Acid feed pump | 4 |
| See Table in Sec. 9 | Well Pumps | 7 |
| P - 241 | Backwash water pump | 1 |
| P - 245 | Reuse water pump | 6 |
| P - 220A,B | GAC adsorber feed pumps | 1 |
| P - 141 | Filter press feed pump | see section on Filter Press |
| X - 132A | Metal scavenger/coagulant pumps | to be purchased |

APPENDIX H

SECTION 1

PUMP DATA

PUMP P - 145

Manufacturer: Goulds

Model: 3196

Size: 1X1.5-6

Manufacturer

Contact: Mike Compton

Phone

Number: (770) 446-3369

PUMP DATA

PUMPS P-110(A,B), P-220(A,B), & P - 241

Manufacturer: Goulds

Model: 3196

Size: 3X4-10H

Manufacturer

Contact: Mike Compton

Phone

Number: (770) 446-3369

GOULDS PUMPS

legould.wp

Site location: Camp Lejeune, OU2, N.C.
Date service man on site: February 8, 1996
Name of service man: Mr. Bill Lynch, 910-799-8800

Questions & Comments:

1. Question: Before you turn on the pump, what item(s) has to be turned on first?

Comments: Before the pump is turned on, the **seal water to the packing** must be turned on first. That means pump P-245 must be turned on to supply the seal water to all the pumps, otherwise the pump packing seals may be damaged. The seal water pump develops 50 psi during today's startup.

2. Question: What other items has to be turned on before starting the pump?

Comments: For all flooded suction pumps (that is pumps sitting at the bottom of the tanks) the pump suction inlet valves and discharge valves have to be opened otherwise the pump could be damaged by dead heading the water.

3. Question: What should the low level shut off in the tank be set at for the pumps to operate properly?

Comments: The low level in the tank for pump shut off should be set at a minimum of 1 foot above the center line of the suction pipe.

4. Question: What pressure should the seal water be set at for the pumps?

Comments: The seal water pressure should be set at approximately 20 to 25 psi. Goulds has issued a recommended seal water pressure list for all the pumps to OHM and this list should be followed. The method of setting the pressure is by setting the seal pressure 10 psi higher than the stuffing box pressure. And the stuffing box pressure is equal to the sum of the suction pressure plus 25% of the discharge pressure.

5. Question: What is the flow rate of water to the pump seals?

Comments: The water flow rate to the pump seal should be approximately 0.5 gpm.

5. Question: What are the maintenance for these pumps?

Comments: The oil in the pumps should be changed after the first 200 hours, and every

3 months or 2,000 hours thereafter.

6. Question: Are there any maintenance needed for the pump motor?

Comments: The pump motor should be greased every 3 months or 2,000 hours. When greasing the motor, be sure to remove the relief plug and see that the old grease comes out.

7. Question: What are other maintenance required?

Comments: The flow and pressure developed by the pump should be checked periodically. If say after one year, the flow and pressure deteriorates, the impeller clearance should be checked and adjusted using the impeller external adjustment bolt. If it does not help, the pump will need to be disassembled and inspected for wear. The impeller and the pump may need to be send in for repair or overhaul.

8. Question: How long do these pumps last?

Comments: If these pumps are properly maintained, they should last minimum two years on up to four to five years or even longer before they will need re-building.

9. Question: If the process has to cycle the pumps on and off, would that hurt the pump?

Comments: Cycling the pump on and off will not hurt the pump as long as the seal water is on and the flow is maintained.

10. Question: What should the rotation of the pump be?

Comments: It is very critical that the pump is turning clockwise or the pump will be damaged. The impeller is screwed on to the shaft, turning counterclockwise will unscrew the impeller and damage the pump.

The clockwise or right hand rotation can be confirmed by standing at the end of the motor and looking at the shaft.

Engineering Document Package

Goulds Serial # 786D828-1-2
Cust: OHM REMEDIATION SERVICES CORP.
P.O. # 1005430
Item # P-110A/B PROJ. CAMP LEJEUNE
Service: STRIPPER FEED PUMPS

SUBMITTAL REVIEW

REVIEW IS FOR GENERAL COMPLIANCE
WITH CONTRACT DOCUMENTS
NO RESPONSIBILITY IS ASSUMED FOR
CORRECTNESS OF DIMENSIONS OR DETAILS.
THE CONTRACTOR/SUPPLIER SHALL ASSUME
FULL RESPONSIBILITY FOR DEVIATIONS FROM
CONTRACT REQUIREMENTS NOT SPECIFICALLY
INDICATED ON THIS SUBMITTAL.

NO EXCEPTIONS MAKE CORRECTIONS
NOTED

AMEND AND
RESUBMIT REJECTED - SEE
REMARKS

Date 6-21-95 By B. Hank

OHM REMEDIATION
SERVICES CORP.
NORCROSS, GEORGIA



GOULDS PUMPS, INC.
INDUSTRIAL PRODUCTS GROUP



GOULDS PUMPS, INC.

INDUSTRIAL PRODUCTS GROUP
ENGINEERED PRODUCTS DIV.

PUMP OUTLINE DRAWING
MODEL 3196 MTX, LTX

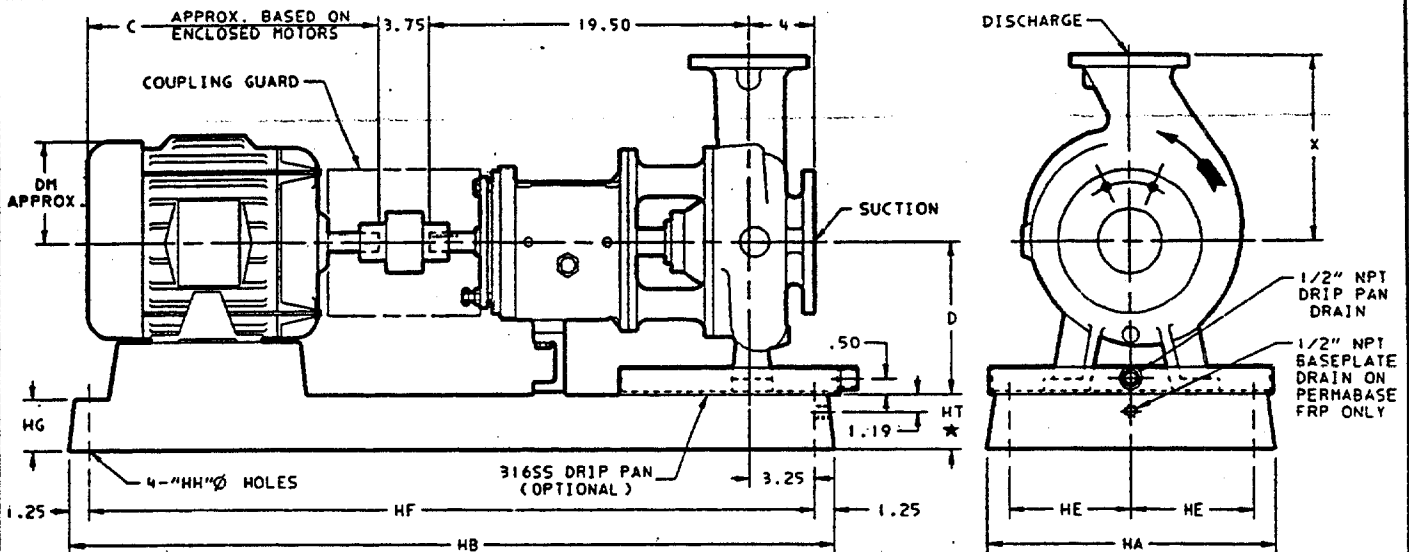

| MOTOR DIMENSIONS (TEFC) | | | | | | |
|-------------------------|------|----|----|-----------------|----------|--|
| MOTORS | | C | DM | WT. INCL. CPLG. | BASE NO. | |
| NEMA | IEC | | | | | |
| 56 | 80 | 11 | 4 | 35 | 1 | |
| 143T | 90S | 13 | 4 | 40 | 1 | |
| 145T | 90L | 14 | 4 | 45 | 1 | |
| 182T | 100L | 15 | 5 | 65 | 1 | |
| 184T | 112M | 16 | 5 | 75 | 1 | |
| 213T | 132S | 18 | 6 | 150 | 1 | |
| 215T | 132M | 20 | 6 | 160 | 1 | |
| 254T | 160M | 23 | 7 | 255 | 2 | |
| 256T | 160L | 24 | 7 | 280 | 2 | |
| 284T | 180M | 26 | 8 | 375 | 2 | |
| 284TS | ---- | 25 | 8 | 345 | 2 | |
| 286T | 180L | 27 | 8 | 430 | 2 | |
| 286TS | ---- | 26 | 8 | 380 | 2 | |
| 324T | 200M | 29 | 9 | 575 | 3 | |
| 324TS | ---- | 27 | 9 | 485 | 3 | |
| 326T | 200L | 30 | 9 | 640 | 3 | |
| 326TS | ---- | 29 | 9 | 570 | 3 | |
| 364T | 225S | 33 | 10 | 810 | 3A | |
| 364TS | ---- | 31 | 10 | 755 | 3A | |
| 365T | 225M | 34 | 10 | 950 | 3A | |
| 365TS | ---- | 32 | 10 | 865 | 3A | |
| 404TS | ---- | 34 | 11 | 1080 | 4 | |
| 405TS | ---- | 36 | 11 | 1110 | 4 | |
| 444TS | ---- | 39 | 13 | 1510 | 4A | |

| BASEPLATE DIMENSIONS | | | | | | | | | | | | | |
|----------------------|----|----|-------------|------|-----------|------|-----------|------|------|-------|------|-----------|-----|
| NO. | HA | HB | HT (D=8.25) | | HT (D=10) | | HG | | HE | HF | HH | WEIGHT | |
| | | | CAST IRON | FRP | CAST IRON | FRP | CAST IRON | FRP | | | | CAST IRON | FRP |
| 1 | 12 | 45 | 3.81 | 3.94 | 3.81 | 3.94 | 3.75 | 3.62 | 4.50 | 42.50 | .75 | 105 | 44 |
| 2 | 15 | 52 | 4.19 | 4.31 | 4.19 | 4.31 | 4.12 | 4.00 | 6.00 | 49.50 | .75 | 155 | 56 |
| 3 | 18 | 58 | 4.81 | 5.06 | 4.81 | 5.06 | 4.75 | 4.75 | 7.50 | 55.50 | 1.00 | 205 | 77 |
| 3A | 18 | 58 | 5.81 | 6.06 | 4.81 | 5.06 | 4.75 | 4.75 | 7.50 | 55.50 | 1.00 | 205 | 77 |
| 4 | 18 | 60 | 6.81 | NA | 5.06 | NA | 4.75 | NA | 7.50 | 57.50 | 1.00 | 240 | NA |
| 4A | 18 | 60 | 7.81 | NA | 6.06 | NA | 4.75 | NA | 7.50 | 57.50 | 1.00 | 240 | NA |

| PUMP DIMENSIONS | | | | | | | |
|-----------------|-------------|------------|-------------|-------|-------|------|--|
| ANSI NO. | DISCH. SIZE | SUCT. SIZE | CAS'G CLASS | D | X | WGT. | |
| A70 | 3 | 4 | 7 | 8.25 | 11.00 | 240 | |
| A60 | 2 | 3 | 8 | 8.25 | 9.50 | 220 | |
| A70 | 3 | 4 | 8G | 8.25 | 11.00 | 240 | |
| A70 | 3 | 4 | 8 | 8.25 | 11.00 | 240 | |
| A05 | 1 | 2 | 10 | 8.25 | 8.50 | 220 | |
| A50 | 1 1/2 | 3 | 10 | 8.25 | 8.50 | 240 | |
| A60 | 2 | 3 | 10 | 8.25 | 9.50 | 250 | |
| A70 | 3 | 4 | 10 | 8.25 | 11.00 | 285 | |
| A40 | 3 | 4 | 10H | 10.00 | 12.50 | 295 | |
| A80 | 4 | 6 | 10 | 10.00 | 13.50 | 325 | |
| A70 | 4 | 6 | 10H | 10.00 | 13.50 | 336 | |
| A20 | 1 1/2 | 3 | 13 | 10.00 | 10.50 | 265 | |
| A30 | 2 | 3 | 13 | 10.00 | 11.50 | 295 | |
| A40 | 3 | 4 | 13 | 10.00 | 12.50 | 350 | |
| A80 | 4 | 6 | 13 | 10.00 | 13.50 | 425 | |

| PUMP MODEL |
|--|
| <input checked="" type="checkbox"/> 3196 MTX |
| <input type="checkbox"/> 3196 LTX |

| AVAILABLE OPTIONS |
|---|
| BASEPLATE: |
| <input checked="" type="checkbox"/> CAST IRON |
| <input type="checkbox"/> PERMABASE™ FRP |
| <input type="checkbox"/> Y-BASE™ |
| 3165S DRIP PAN: |
| <input type="checkbox"/> FURNISHED |
| <input checked="" type="checkbox"/> NOT FURNISHED |
| FLANGES: |
| <input checked="" type="checkbox"/> 150# ANSI FLAT FACE |
| <input type="checkbox"/> 150# ANSI RAISED FACE |
| <input type="checkbox"/> 300# ANSI FLAT FACE |
| <input type="checkbox"/> 300# ANSI RAISED FACE |
| CPLG. GUARD FURNISHED BY: |
| <input checked="" type="checkbox"/> GOULDS |
| <input type="checkbox"/> OTHERS |

INSTALL FOUNDATION IN PIPE SLEEVES. ALLOW .75 TO 1.50 FOR GROUTING. SEE INSTRUCTION BOOK FOR DETAILS.

◆ SUCTION FLANGE HAS (8) 3/4-10 UNC TAPPED HOLES FOR 300# CASING ONLY.

■ SUCTION FLANGE HAS (8) 3/4-10 UNC TAPPED HOLES FOR 150# CASING. (12) 3/4 10 UNC TAPPED HOLES FOR 300# CASING.

◆ FOR 3196 LTX. ADD 20 LBS. TO PUMP WEIGHT GIVEN.

★ TOLERANCE IS +0 -.50 FOR CAST IRON BASEPLATE.

FOR TAPPED OPENINGS REFER TO DRAWING A04196A

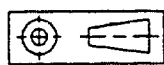

CERTIFIED FOR CONSTRUCTION PURPOSES ONLY WHEN SIGNED.

SIGNATURE *Joyce Sutterby* DATE *6-8-95*

Goulds Serial # 786D828-1-2
Cust: OHM REMEDIATION SERVICES CORP.
P.O. # 1005430
Item # P-110A/B PROJ. CAMP LEJUNE
Service: STRIPPER FEED PUMPS

| | | | | | |
|-------|--|--------------------------|--------------------|---------------|------------|
| ISSUE | DRAWING IS NOT TO SCALE DIMENSIONS IN INCHES WEIGHTS (LBS) ARE APPROXIMATE | DRAWN DDT 08-14-92 | DRAWING A04487A | REVISION 0 | ISSUE 0 |
| | | APPROVED PTM 05-14-93 | | | |



GOULDS PUMPS, INC.

INDUSTRIAL PRODUCTS GROUP
ENGINEERED PRODUCTS DIV.

PUMP TAPPED OPENINGS
MODEL 3196 MTX, LTX

TAPPED OPENINGS

| NO. | SIZE | QTY. | PURPOSE | FURNISHED | | NO. | SIZE | QTY. | PURPOSE | FURNISHED | |
|-----|------|------|-----------------------|-----------|----|-----|------|------|-------------------------|-----------|----|
| | | | | YES | NO | | | | | YES | NO |
| TB | 1/2 | 1 | CASING DRAIN | X | | TL1 | --- | 2 | FRAME COOLER ACCESS | X | |
| TC | 1/2 | 1 | BY-PASS CONNECTION | | X | TN | 1/4 | 4 | GREASE FITTING | X | |
| TD | 3/8 | 1 | DISCHARGE GAUGE CONN. | X | | TN2 | 1/4 | 2 | OIL MIST INJECTION PORT | X | |
| TE | 3/8 | 1 | SUCTION GAUGE CONN. | | | TY | 1/2 | 1 | OIL FILL | X | |
| TF | 3/8 | 1 | BEARING FRAME DRAIN | X | | TZ | 1/4 | 1 | BOTTLE OILER CONNECTION | X | |
| TL | 1/2 | 2 | FRAME COOLING CONN. | | X | | | | | | |

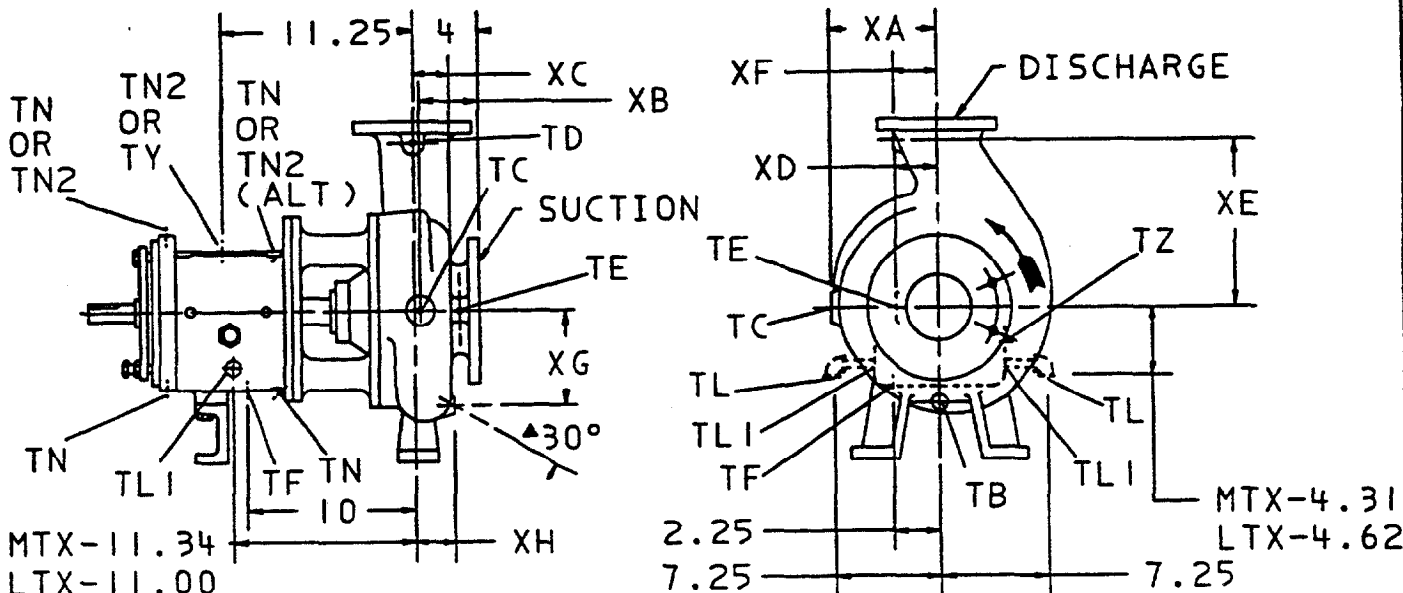

PUMP DIMENSIONS

| ANSI NO. | SIZE | XA | XB | XC | XD | XE | XF | XG | XH |
|----------|------------|------|------|------|------|-------|------|------|------|
| A70 | 3X4-7 | 5.88 | 3.81 | NA | NA | 9.12 | 2.12 | 5.75 | 1.75 |
| A60 | 2X3-8 | 5.88 | 3.81 | 2.38 | 2.00 | 8.00 | 1.50 | 4.62 | 1.44 |
| A70 | 3X4-8G | 5.88 | 3.69 | 2.38 | 2.62 | 9.31 | 2.06 | 5.12 | 1.81 |
| A70 | 3X4-8 | 6.12 | 3.38 | 2.62 | 2.75 | 9.12 | 2.12 | 5.88 | 2.38 |
| A05 | 1X2-10 | 6.00 | 4.12 | 2.38 | 1.75 | 7.25 | 1.00 | 5.38 | 1.00 |
| A50 | 1 1/2X3-10 | 6.75 | 4.25 | 2.38 | 2.38 | 7.19 | 1.00 | 5.81 | 1.03 |
| A60 | 2X3-10 | 6.75 | 4.12 | 2.38 | 2.38 | 7.88 | 1.31 | 5.56 | 1.12 |
| A70 | 3X4-10 | 6.75 | 4.00 | 2.38 | 2.62 | 9.12 | 1.75 | 5.88 | 1.50 |
| X A40 | 3X4-10H | 7.62 | 4.00 | NA | NA | 10.62 | 2.12 | 6.88 | 1.88 |
| A80 | 4X6-10 | 6.88 | 3.56 | NA | NA | 11.38 | 2.44 | 7.25 | 2.50 |
| A70 | 4X6-10H | 7.94 | 4.00 | NA | NA | 11.38 | 2.50 | 7.62 | 3.34 |
| A20 | 1 1/2X3-13 | 8.25 | 4.25 | 2.25 | 2.06 | 8.94 | 1.25 | 7.19 | 1.38 |
| A30 | 2X3-13 | 8.25 | 4.12 | 2.38 | 2.19 | 9.88 | 1.50 | 7.44 | 1.94 |
| A40 | 3X4-13 | 8.50 | 4.00 | 2.62 | 2.62 | 10.62 | 2.12 | 7.88 | 1.69 |
| A80 | 4X6-13 | 8.69 | 3.88 | NA | NA | 11.38 | 2.50 | 8.38 | 2.62 |

CERTIFIED FOR CONSTRUCTION PURPOSES ONLY WHEN SIGNED.

SIGNATURE *Joyce Sutterby* DATE 6-8-95

PUMP MODEL

- 3196 MTX
- 3196 LTX

◆XD=2.38 FOR 300# CASING.

●XB=3.25 FOR 300# CASING.

▲30° ON SIZE 2X3-6, 3X4-7, & 4X6-10 ONLY. ALL OTHERS ARE HORIZONTAL.

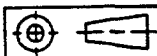

Goolds Serial # 786D828-1-2
 Cust: OHM REMEDIATION SERVICES CORP.
 P.O. # 1005430
 Item # P-110A/B PROJ. CAMP LEJBUNB
 Service: STRIPPER FEED PUMPS

| | | | | | |
|-------|---|----------------------------|--------------------|---------------|------------|
| ISSUE | DRAWING IS NOT TO SCALE DIMENSIONS IN INCHES | DRAWN DDT 3-25-91 | DRAWING A04196A | REVISION 3 | ISSUE 0 |
| | | APPROVED RAS 6-24-91 | | | |



GOULDS PUMPS, INC.

INDUSTRIAL PRODUCTS GROUP
ENGINEERED PRODUCTS DIV.

PUMP TAPPED OPENINGS
GROUP-MTX/LTX

STUFFING BOX/SEAL CHAMBERS/DYNAMIC SEAL

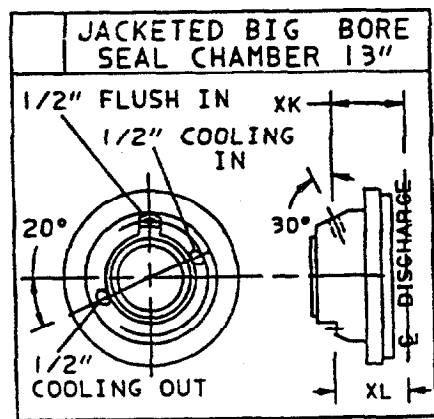
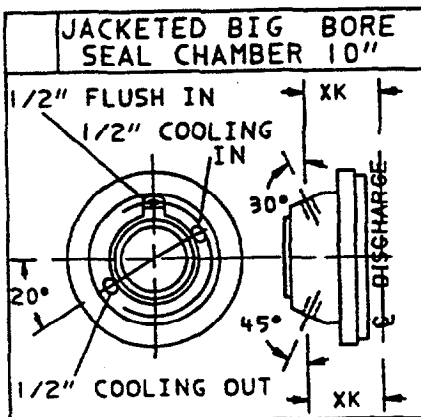
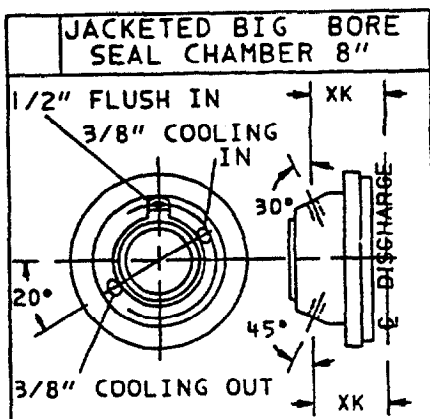
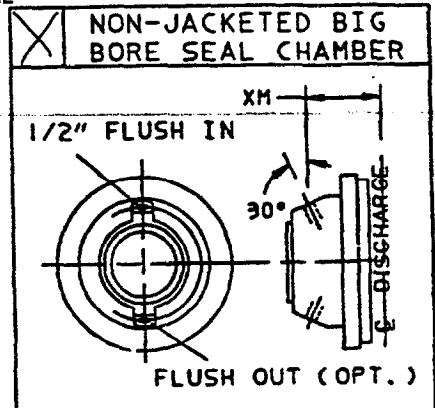
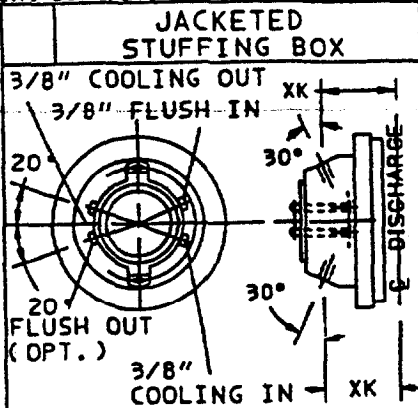
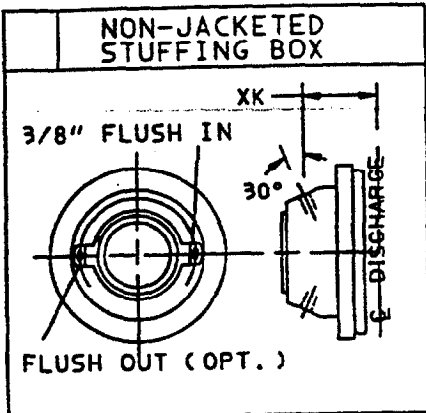

| PUMP DIMENSIONS | | | | | |
|--|-------|--------------|-------|-------|--|
| PUMP MODEL | XK | (MAXIMUM) XJ | XL | XM | |
| <input checked="" type="checkbox"/> 3196 | 3.38 | 2.50 | 3.06 | 3.50 | |
| 3796: 2X2-10 | 5.50 | 4.81 | 5.19 | 5.62 | |
| 3X3-10 | 6.38 | 5.69 | 6.06 | 6.50 | |
| 4X4-10 | 7.12 | 6.44 | 6.81 | 7.25 | |
| 3X3-13 | 6.38 | 5.69 | 6.06 | 6.50 | |
| 4X4-13 | 7.12 | 6.44 | 6.81 | 7.25 | |
| 6X6-13 | 11.50 | 10.81 | 11.19 | 11.62 | |
| 3996 | 3.88 | 3.00 | 3.56 | 4.00 | |
| LF 3196 | 3.38 | 2.50 | 3.06 | 3.50 | |
| CV 3196: 2X2-10 | 5.50 | 4.81 | 5.38 | 5.62 | |
| 3X3-10 | 6.19 | 5.69 | 6.06 | 6.31 | |
| 2X3-13 | 6.00 | 5.69 | 5.88 | 6.19 | |
| 3X4-13 | 6.50 | 6.44 | 6.06 | 6.69 | |

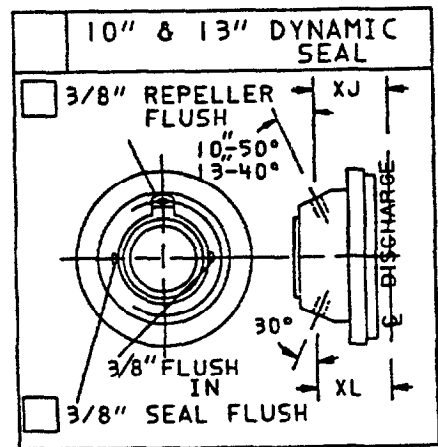

GROUP

MTX

LTX

NOTE: TAPPED OPENINGS NOT AVAILABLE ON TAPER BORE™ PLUS SEAL CHAMBERS

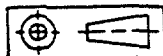

8" DYNAMIC SEAL IS NOT AVAILABLE

CERTIFIED FOR CONSTRUCTION PURPOSES ONLY WHEN SIGNED.

SIGNATURE *Joyce Sutterby* DATE 6-8-95

Goulds Serial # 786D828-1-2
Cust: OHM REMEDIATION SERVICES CORP.
P.O. # 1005430
Item # P-110A/B PROJ. CAMP LEJUNE
Service: STRIPPER PRED PUMPS

ISSUE

DRAWING IS NOT TO SCALE
DIMENSIONS IN INCHES

DRAWN TJA
8-31-94
APPROVED PTH
9-6-94

DRAWING
A05461A

REVISION
0

ISSUE
0

**STUFFING BOX/SEAL CHAMBER GLAND OPTIONS
OPTION FURNISHED WHEN CHECKED**

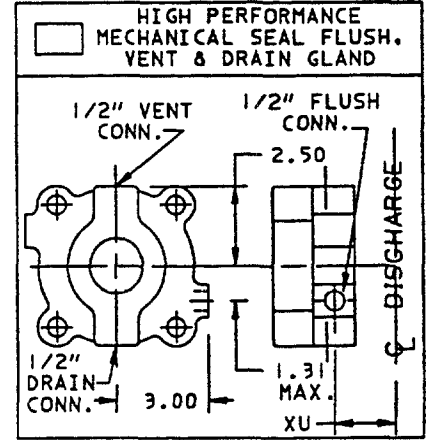
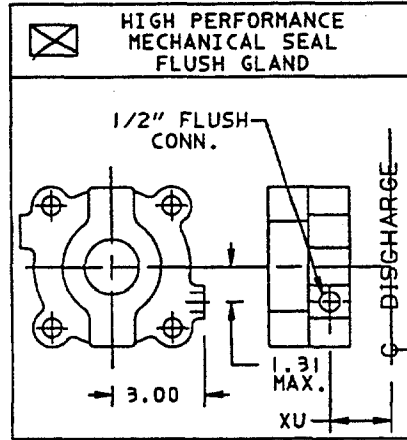
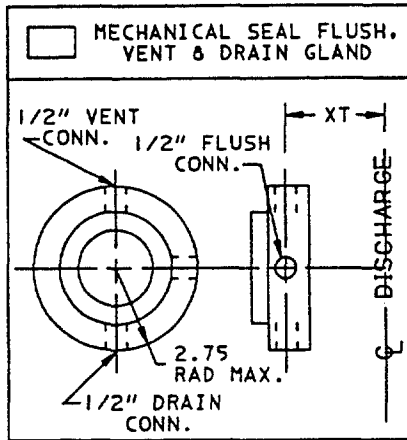
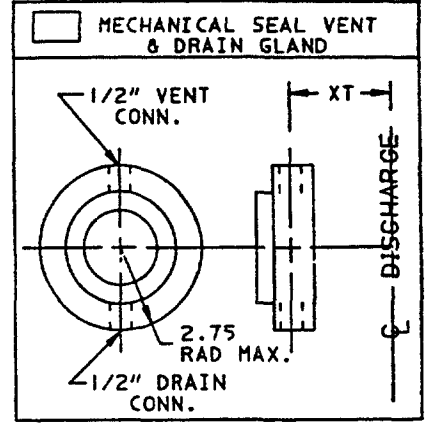
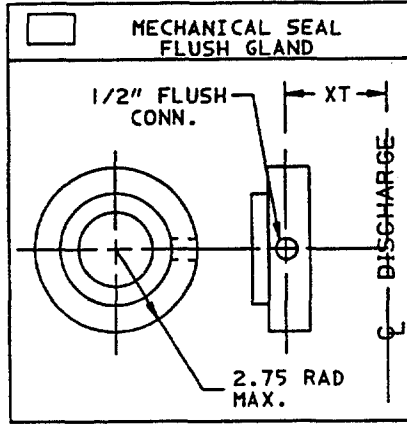
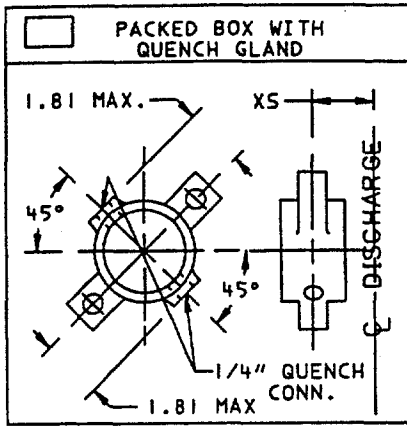

| PUMP MODEL | PUMP DIMENSIONS (MAXIMUM) | | |
|--|---------------------------|-------|-------|
| | XS | XT | XU |
| <input checked="" type="checkbox"/> 3196 | 4.88 | 4.75 | 4.62 |
| <input type="checkbox"/> 3796: 2X2-10 | 7.12 | 7.00 | 6.81 |
| <input type="checkbox"/> 3X3-10 | 8.00 | 7.88 | 7.69 |
| <input type="checkbox"/> 4X4-10 | 8.75 | 8.62 | 8.44 |
| <input type="checkbox"/> 3X3-13 | 8.00 | 7.88 | 7.69 |
| <input type="checkbox"/> 4X4-13 | 8.75 | 8.62 | 8.44 |
| <input type="checkbox"/> 6X6-13 | 13.12 | 13.00 | 12.81 |
| <input type="checkbox"/> 3996 | 5.38 | 5.25 | 5.12 |
| <input type="checkbox"/> LF 3196 | 4.88 | 4.75 | 4.62 |
| <input type="checkbox"/> CV 3196: 2X2-10 | 7.12 | 7.00 | 6.81 |
| <input type="checkbox"/> 3X3-10 | 7.81 | 7.69 | 7.52 |
| <input type="checkbox"/> 2X3-13 | 7.69 | 7.56 | 7.36 |
| <input type="checkbox"/> 3X4-13 | 8.19 | 8.06 | 7.86 |

| GROUP | |
|-------------------------------------|-----|
| <input checked="" type="checkbox"/> | MTX |
| <input type="checkbox"/> | LTX |

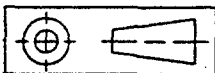

CERTIFIED FOR CONSTRUCTION PURPOSES ONLY WHEN SIGNED.

SIGNATURE *Joyce Sutterby* DATE *6-8-95*

Goolds Serial # 786D828-1-2
Cust: OHM REMEDIATION SERVICES CORP.
P.O. # 1005430
Item # P-110A/B PROJ. CAMP LBJEUNE
Service: STRIPPER FBBD PUMPS

ISSUE

DRAWING IS NOT TO SCALE
DIMENSIONS IN INCHES

DRAWN TJA
09-01-94
CHECKED PTM
09-06-94

DRAWING
A05469A

REVISION
0

ISSUE
0

DATE 2-26-81

REV. DATE 3-29-93 ISSUE #1
1-30-91 ISSUE #2
1-8-87 ISSUE #2
10-8-82 ISSUE #1

GOULDS PUMPS, INC.
SENECA FALLS, NEW YORK 13148

CENTRIFUGAL PUMP CHARACTERISTICS

RPM 1750 CDS 2929-4

MODEL 3196

SIZE 3x4-10H

IMP. DWG. C00262A01 C00262A02

PATTERN 58009 58434

EYE AREA 17.5 in²

9 1/2" IMP. DIA.

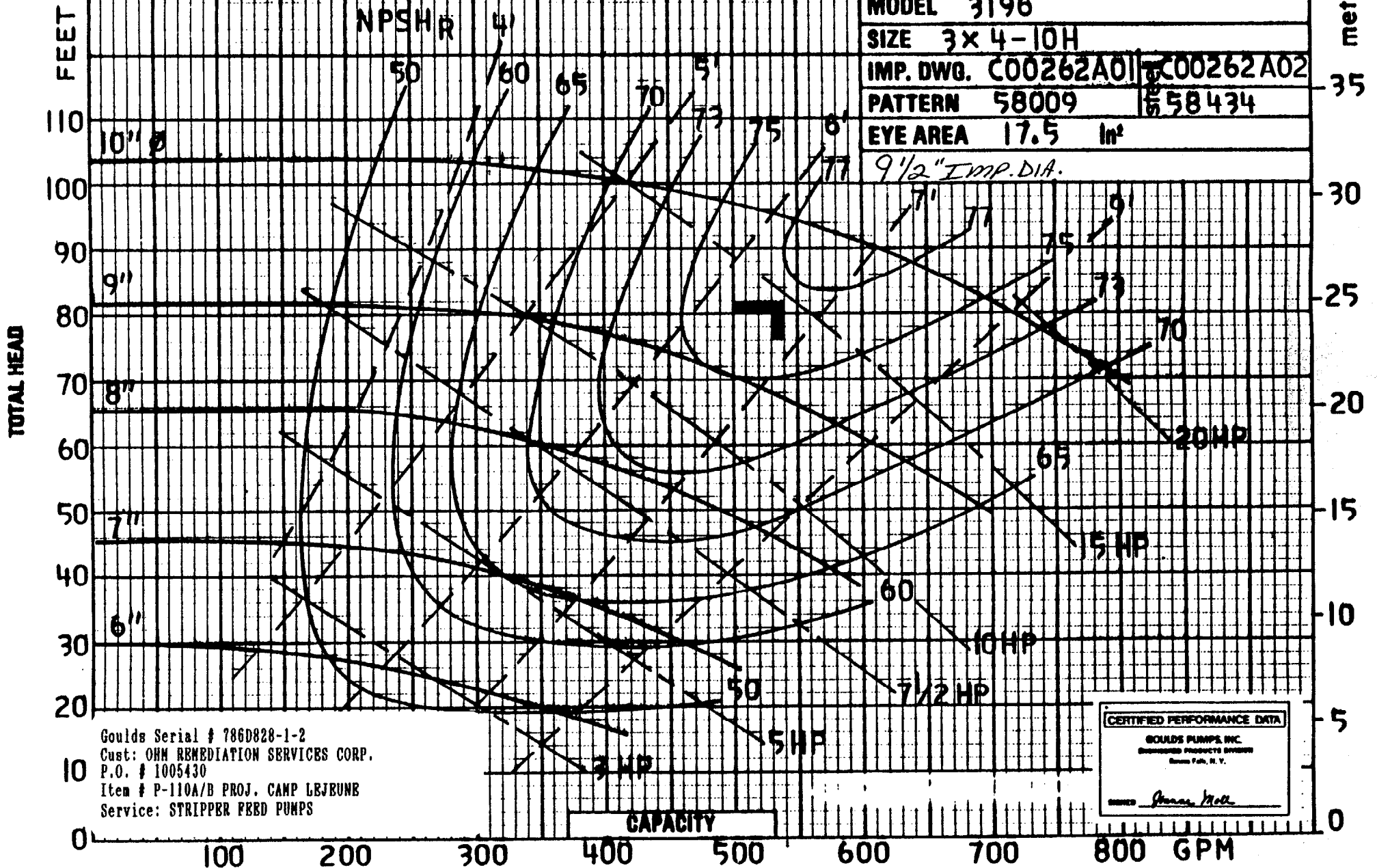

Goolds Serial # 786D828-1-2
Cust: OHM REMEDIATION SERVICES CORP.
P.O. # 1005430
Item # P-110A/B PROJ. CAMP LEJEUNE
Service: STRIPPER FEED PUMPS

CERTIFIED PERFORMANCE DATA
GOULDS PUMPS, INC.
DESIGNED PRODUCTS DIVISION
Seneca Falls, N.Y.
James Moll

BILL OF MATERIAL
CONSTRUCTION: DUCTILE IRON

BOTTLE OILER
OPTION FURNISHED WHEN CHECKED

STANDARD OIL LUBE

| ITEM NO | QTY PER PUMP | PART NAME | MATERIAL |
|---------|--------------|--------------------------|-----------|
| 100 | 1 | CASING | DI |
| 101 | 1 | IMPELLER | 316SS |
| 105 | 2 | LANTERN RING HALF | TEFLON |
| 106 | 1 | STUFFING BOX PKG | NON-ASS |
| 107 | 1 | GLAND | 316SS |
| 108 | 1 | FRAME ADAPTER | DI |
| 112A | 1 | BALL BRG OTBD | STEEL |
| 113A | 1 | PLUG.OIL FILL | STEEL |
| 122 | 1 | SHAFT | STEEL |
| 126 | 1 | SHAFT SLEEVE | 316SS |
| 134 | 1 | BRG HOUSING | CI |
| 136 | 1 | BRG LOCK NUT | STEEL |
| 168A | 1 | BALL BRG INBD | STEEL |
| 184 | 1 | S.B. COVER/SEAL CHAM. | DI |
| 228 | 1 | FRAME | CI |
| 241 | 1 | FRAME FOOT | CI |
| 319 | 1 | SIGHT GLASS | STL/GLASS |
| 332A | 1 | LBYSR SEAL OTBD W/O-RING | TFL/GPH |
| 333A | 1 | LBYSR SEAL INBD W/O-RING | TFL/GPH |
| 351 | 1 | GASKET-CASE | EPDM-RBR |
| 353 | 2 | STUD-GLAND | 316SS |
| 355 | 2 | NUT GLAND STUD | 304SS |
| 360D | 1 | GASKET-FR-ADPTR | VELLUMOID |
| 361A | 1 | RTNG RING-BRG HSG | STEEL |
| 370 | 8 | H CAP SCR-ADPTR-CASE | STEEL |
| 370B | 4 | H CAP SCR-ADPTR-FR | STEEL |
| 370C | 3 | H TAP BOLT-BRG HSG | STEEL |
| 370D | 3 | H TAP BOLT-IMPLR-ADJ | STEEL |
| 370F | 2 | H CAP SCR-FR-FOOT | STEEL |
| 370H | 2 | STUD-COVER-ADPTR | 304SS |
| 382 | 1 | BRG LOCKWASHER | STEEL |
| 400 | 1 | KEY SQUARE | STEEL |
| 408A | 1 | MAG. PLUG-OIL DRAIN | STEEL |
| 408J | 1 | PLUG.SIGHT OILER | STEEL |
| 408H | 4 | PLUG.OIL MIST CONN | STEEL |
| 412A | 1 | O-RING IMPELLER | TEFLON |
| 418 | 3 | H TAP BOLT-JACKING | 304SS |
| 423 | 3 | JAM NUT FOR 370D | STEEL |
| 469B | 2 | DOWEL PIN-FR-ADPTR | ALLOY-ST |
| 496 | 1 | O-RING-BRG HSG | BUNA-RBR |
| 497F | 1 | O-RING.OTBD SEAL ROT. | VITON |
| 497G | 1 | O-RING.OTBD SEAL STA. | VITON |
| 497H | 1 | O-RING.INBD SEAL ROT. | VITON |
| 497J | 1 | O-RING.INBD SEAL STA. | VITON |

| ITEM NO | NO REQ'D | PART NAME | MAT'L |
|---------|----------|--------------|------------|
| 133 | 1 | PIPE NIPPLE | STEEL |
| 251 | 1 | BOTTLE OILER | ALUM/GLASS |

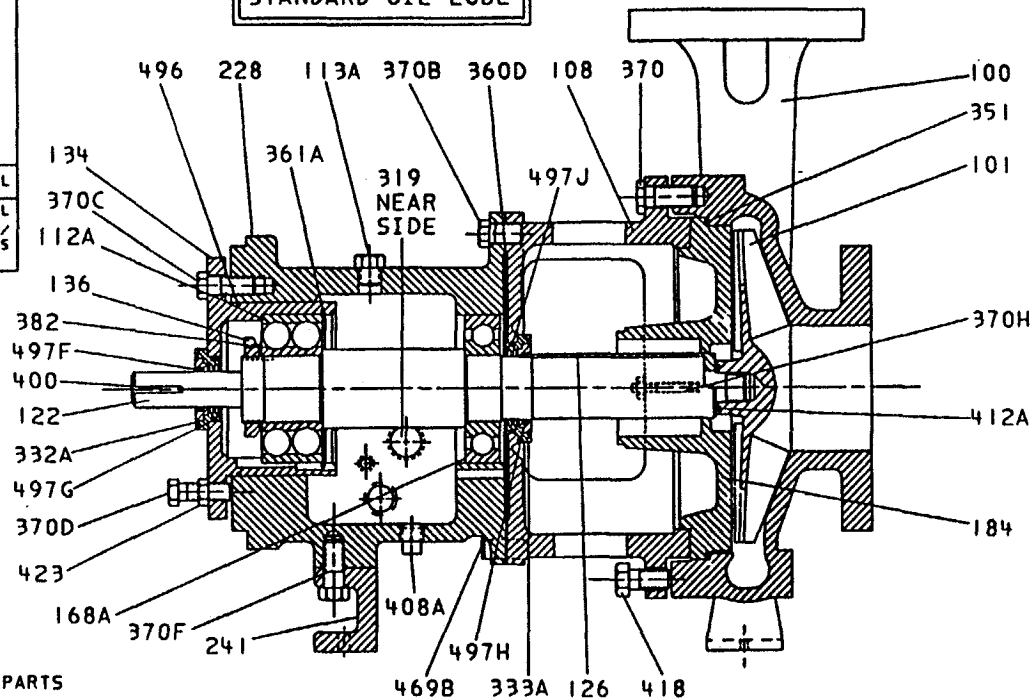
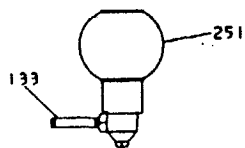

* RECOMMENDED SPARE PARTS

Ⓐ ITEM 370 IS QTY 12 FOR 10" CASINGS & QTY 16 FOR 13" CASINGS.

Ⓑ GLAND BOLTING FOR PACKING GLAND (ITEM 353 & 355) IS QTY 2. FOR MECHANICAL SEAL QTY 4.

Ⓒ ITEMS NOT ILLUSTRATED.

STUFFING BOX COVER / SEAL CHAMBER OPTIONS - CHECK OPTION REQUIRED

STUFFING BOX

REFER TO SEAL DRAWING NO. 265-24801

ATTACHED

TO FOLLOW

NONJACKETED (SHOWN)
 JACKETED

TAPER BORE™ PLUS

BIG BORE™ STD. FLUSH

BIG BORE™ W/ INTERNAL BY-PASS

NONJACKETED (SHOWN)
 JACKETED

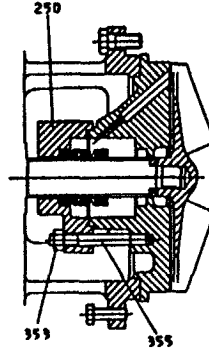
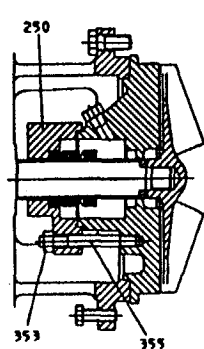
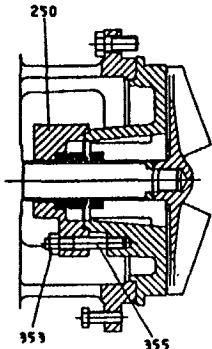
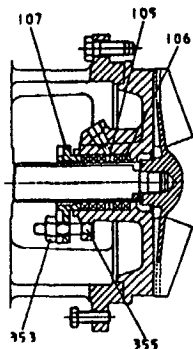

Goulds Serial # 786D828-1-2
Cust: OHM REMEDIATION SERVICES CORP.
P.O. # 1005430
Item # P-110A/B PROJ. CAMP LEJUNG
Service: STRIPPBR FRBD PUMPS

PUMP CROSS SECTION DRAWING
MODEL 3196MTX



GOULDS PUMPS, INC.
INDUSTRIAL PRODUCTS GROUP
ENGINEERED PRODUCTS DIV.

DRAWN
THO
05/20/91

CHECKED
THO
05/20/91

APPROVED
RAS
06/28/91

THIRD ANGLE
PROJECTION

DRAWING IS NOT TO SCALE

DRAWING

B02917A2

REV.

2

Goulds Serial # 786D828-1-2
 Cust: OHM REMEDIATION SERVICES CORP.
 P.O. # 1005430
 Item # P-110A/B PROJ. CAMP LEJBUNB
 Service: STRIPPER PBD PUMPS

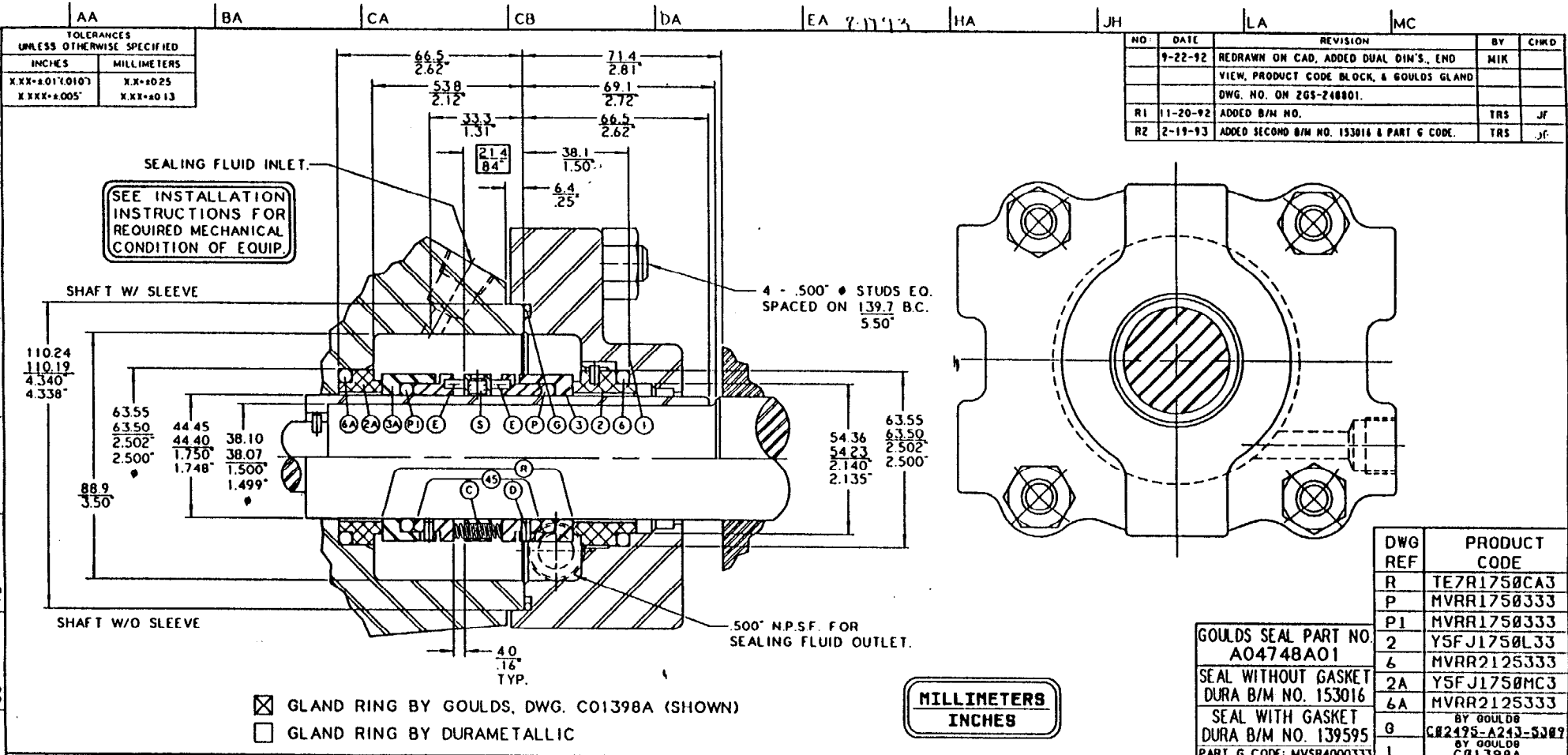

| NO. | DATE | REVISION | BY | CHKD |
|-----|----------|--|-----|------|
| | 9-22-92 | REDRAWN ON CAD, ADDED DUAL OIM'S, END VIEW, PRODUCT CODE BLOCK, & GOULDS GLAND DWG. NO. ON ZGS-248801. | MIK | |
| R1 | 11-20-92 | ADDED B/M NO. | TRS | JF |
| R2 | 2-19-93 | ADDED SECOND B/M NO. 153016 & PART G CODE. | TRS | JF |

| DWG REF | PRODUCT CODE |
|---------|-------------------------------|
| R | TE7R1750CA3 |
| P | MVRR1750333 |
| P1 | MVRR1750333 |
| 2 | YSFJ1750L33 |
| 6 | MVRR2125333 |
| 2A | YSFJ1750MC3 |
| 6A | MVRR2125333 |
| G | BY GOULDS C82495-A243-5307 |
| 1 | BY GOULDS C01398A |

GOULDS SEAL PART NO. AO4748AO1
 SEAL WITHOUT GASKET DURA B/M NO. 153016
 SEAL WITH GASKET DURA B/M NO. 139595
 PART G CODE: MYSR4000333

| R | ROTAARY UNIT CONSISTING OF: | P | SHAFT PKG. | VITON |
|----|---------------------------------|----|-------------|----------------|
| 3 | SEAL RING <i>TUNARB 62-6</i> | P1 | SHAFT PKG. | VITON 1 |
| 3 | SEAL RING <i>TUNARB 62-6</i> | 2 | INSERT | NO. 5 CARBON |
| 45 | COMP. UNIT 316 SS | 6 | INSERT MTG. | VITON |
| C | SPRINGS 20 SS | 2A | INSERT | NO. 5 CARBON |
| D | DRIVE PINS 20 SS | 6A | INSERT MTG. | VITON |
| E | SPRING PINS 20 SS | G | GASKET | <i>NON-ASB</i> |
| S | SET SCREWS 20 SS | 1 | GLAND RING | <i>316SS</i> |

| | |
|--|---|
| CUSTOMER: GOULDS PUMPS, INC., SENECA FALLS, NY | |
| P.O. NO.: | F.O.NO.: |
| USER: | |
| EQUIP. TYPE & SIZE GOULDS 3196 MT & MTX ANSI PLUS PUMPS | EQUIP. SERIAL NO. 786D828 |
| EQUIP. ITEM NO.: | PRODUCT |
| REFERENCE DWG. NO. C01391A | TEMP: <i>70°F</i> RPM: <i>1800</i> SP. GR.: <i>1.00</i> |
| PRESSURES | BOX |
| SUCT.: | DISCH.: |

| | |
|--|----------------------------------|
| DURA SEAL TYPE | SEAL SIZE |
| DOUBLE INSIDE RO | 1.750" |
| DURAMETALLIC CORPORATION KALAMAZOO, MICHIGAN | |
| MATL CODE | E U 5 - - V V |
| SCALE: .72"=1.00" | ORDER PARTS BY B/M NO: SEE ABOVE |
| DATE: 4-29-89 | DATE: 9-28-92 |
| DWN. TC | CHKD. GB |
| APPROBY: | DWN. PGP |
| FORM DWG: | CHKD. GB |
| 2GS-248801 | DWG. NO.: 786D828#3 |

RECOMMENDED SPARE PARTS: 2, 2A, 3, 3A, 6, 6A, C, G, P, P1, S



GOULDS PUMPS, INC.
ENGINEERED PRODUCTS DIVISION

LUBRICANT DATA SHEET

CUSTOMER INFORMATION

Goulds Serial # 786D828-1-2
Cust: OHM REMEDIATION SERVICES CORP.
P.O. # 1005430
Item # P-110A/B PROJ. CAMP LEJEUNE
Service: STRIPPER FEED PUMPS

EQUIPMENT IDENTIFICATION

MODEL 3196MTX SIZE 3X4-10H
LUBRICATION OIL
CONST. DI / 316SS

| PART LUBRICATED | LUBRICANT | | FILL CAPACITY | CONSUMPT. AMT. / TIME | RECOMMENDED LUBRICANT MFR. & NO. & REMARKS |
|-----------------------|------------------|------------|---------------------------|---|--|
| | TYPE | VISC OSITY | | | |
| BEARING HOUSING FRAME | TURBINE TYPE OIL | ISO VG68 | APPROX. 2.6 PTS (1250 ML) | REFILL APPROXIMATELY EVERY(3) MONTHS OR 2000 HRS. | OIL MUST BE VISIBLE AT CENTER OF SIGHT GLASS |

REV. DATE

| | | | | | |
|--|--|------------|-------------|-------------|------|
| | | WRITTEN BY | APPROVED BY | DRAWING NO. | REV. |
| | | DATE | DATE | 196 MTX LDS | 0 |

SHEET 1 OF 1



TYPE SC SPACER COUPLINGS

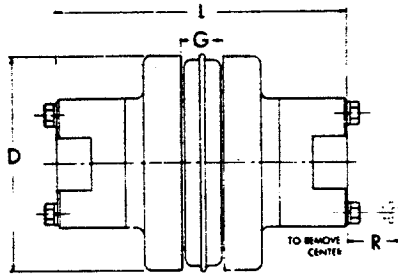
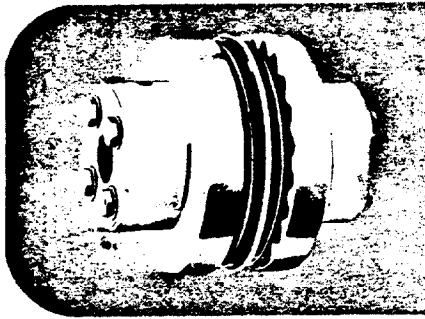

The table below shows assembled dimensions of Sure-Flex Type SC Spacer Couplings. For dimensions of separate components, refer to page 19.

| Coupling Size | Required Distance Between Shafts | Use Flange No. | Use Hub No. | Max. Bore Std. KS | Dimensions | | | | Wt. ⁽²⁾ (lbs.) ■ |
|---------------|----------------------------------|----------------|-----------------|--------------------------------|------------------|-------------------|------------------|------------------|-----------------------------|
| | | | | | D | L ⁽¹⁾ | G | R | |
| 4JSC | 3 $\frac{1}{2}$ | 4JSC35 | | 1 $\frac{1}{8}$ ⁽¹⁾ | 2.460 | 5 $\frac{1}{2}$ | $\frac{5}{8}$ | | 2.7 |
| 5SC | 3 $\frac{1}{2}$ | 5SC35 | 5H | 1 $\frac{1}{8}$ | 3.250 | 5 $\frac{1}{2}$ | $\frac{3}{4}$ | $\frac{9}{16}$ | 4.5 |
| 6SC | 3 $\frac{1}{2}$ | 6SC35 | 6H | 1 $\frac{1}{2}$ | 4.000 | 5 $\frac{1}{2}$ | $\frac{7}{8}$ | $\frac{3}{4}$ | 7.3 |
| | 4 $\frac{1}{2}$ | 6SC44 | 6H | 1 $\frac{1}{2}$ | 4.000 | 6 $\frac{1}{2}$ | $\frac{7}{8}$ | $\frac{3}{4}$ | 8.1 |
| | 5 | 6SC50 | 6H | 1 $\frac{1}{2}$ | 4.000 | 7 $\frac{1}{2}$ | $\frac{7}{8}$ | $\frac{3}{4}$ | 8.7 |
| 7SC | 3 $\frac{1}{2}$ | 7SC35 | 7H | 1 $\frac{1}{2}$ | 4.625 | 6 $\frac{1}{2}$ | 1 | $\frac{5}{8}$ | 9.9 |
| | 4 $\frac{1}{2}$ | 7SC44 | 7H | 1 $\frac{1}{2}$ | 4.625 | 7 $\frac{1}{2}$ | 1 | $\frac{5}{8}$ | 10.8 |
| | 5 | 7SC50 | 7H | 1 $\frac{1}{2}$ | 4.625 | 7 $\frac{1}{2}$ | 1 | $\frac{5}{8}$ | 11.4 |
| 8SC | 3 $\frac{1}{2}$ | 8SC35 | 8H | 1 $\frac{1}{2}$ | 5.450 | 6 $\frac{1}{2}$ | 1 $\frac{1}{8}$ | $\frac{13}{16}$ | 15.2 |
| | | 8SC35-10 | 10H* | 2 $\frac{1}{8}$ | 5.450 | 8 $\frac{1}{2}$ | 1 $\frac{1}{8}$ | $\frac{13}{16}$ | 23.2 |
| | 4 $\frac{1}{2}$ | 8SC44 | 8H | 1 $\frac{1}{2}$ | 5.450 | 7 $\frac{1}{2}$ | 1 $\frac{1}{8}$ | $\frac{13}{16}$ | 16.4 |
| | | 8SC50 | 8H | 1 $\frac{1}{2}$ | 5.450 | 8 $\frac{1}{2}$ | 1 $\frac{1}{8}$ | 1 $\frac{1}{16}$ | 17.4 |
| | 8SC50-10 | 10H* | 2 $\frac{1}{8}$ | 5.450 | 9 $\frac{1}{2}$ | 1 $\frac{1}{8}$ | 1 $\frac{1}{16}$ | 27.2 | |
| 9SC | 3 $\frac{1}{2}$ | 9SC35 | 9H* | 2 $\frac{1}{8}$ | 6.350 | 7 $\frac{1}{2}$ | 1 $\frac{1}{16}$ | 1 $\frac{1}{16}$ | 18.6 |
| | 4 $\frac{1}{2}$ | 9SC44 | 9H* | 2 $\frac{1}{8}$ | 6.350 | 8 $\frac{1}{2}$ | 1 $\frac{1}{16}$ | 1 $\frac{1}{16}$ | 22.2 |
| | | 9SC50 | 9H* | 2 $\frac{1}{8}$ | 6.350 | 8 $\frac{1}{2}$ | 1 $\frac{1}{16}$ | 1 $\frac{1}{16}$ | 23.2 |
| | 5 | 9SC50-11 | 11H* | 2 $\frac{1}{8}$ | 6.350 | 10 $\frac{1}{2}$ | 1 $\frac{1}{16}$ | 1 $\frac{1}{16}$ | 40.4 |
| | 7 | 9SC70-11 | 11H* | 2 $\frac{1}{8}$ | 6.350 | 12 $\frac{1}{2}$ | 1 $\frac{1}{16}$ | 1 $\frac{1}{16}$ | 48.2 |
| | 9SC78-11 | 11H* | 2 $\frac{1}{8}$ | 6.350 | 13 $\frac{1}{2}$ | 1 $\frac{1}{16}$ | 1 $\frac{1}{16}$ | 51.0 | |
| 10SC | 4 $\frac{1}{2}$ | 10SC48 | 10H* | 2 $\frac{1}{8}$ | 7.500 | 9 $\frac{1}{2}$ | 1 $\frac{1}{2}$ | 1 $\frac{1}{16}$ | 37.6 |
| | 5 | 10SC50 | 10H* | 2 $\frac{1}{8}$ | 7.500 | 9 $\frac{1}{2}$ | 1 $\frac{1}{2}$ | 1 $\frac{1}{16}$ | 38.4 |
| | 7 | 10SC70-13 | 13H* | 3 $\frac{1}{8}$ | 7.500 | 13 $\frac{1}{2}$ | 1 $\frac{1}{2}$ | 1 $\frac{1}{8}$ | 72.0 |
| | 7 $\frac{1}{2}$ | 10SC78-13 | 13H* | 3 $\frac{1}{8}$ | 7.500 | 14 $\frac{1}{2}$ | 1 $\frac{1}{2}$ | 1 $\frac{1}{8}$ | 76.0 |
| 10 | 10SC100-13 | 13H* | 3 $\frac{1}{8}$ | 7.500 | 16 $\frac{1}{2}$ | 1 $\frac{1}{2}$ | 1 $\frac{1}{8}$ | 88.0 | |
| 11SC | 4 $\frac{1}{2}$ | 11SC48 | 11H* | 2 $\frac{1}{8}$ | 8.625 | 10 $\frac{1}{16}$ | 1 $\frac{1}{2}$ | 1 $\frac{1}{8}$ | 54.5 |
| | 5 | 11SC50 | 11H* | 2 $\frac{1}{8}$ | 8.625 | 10 $\frac{1}{16}$ | 1 $\frac{1}{2}$ | 1 $\frac{1}{8}$ | 54.7 |
| | 7 | 11SC70-14 | 14H | 3 $\frac{1}{8}$ | 8.625 | 14 $\frac{1}{2}$ | 1 $\frac{1}{2}$ | 2 | 86.1 |
| | 7 $\frac{1}{2}$ | 11SC78-14 | 14H | 3 $\frac{1}{8}$ | 8.625 | 15 $\frac{1}{8}$ | 1 $\frac{1}{2}$ | 2 | 90.3 |
| 10 | 11SC100-14 | 14H | 3 $\frac{1}{8}$ | 8.625 | 17 $\frac{1}{8}$ | 1 $\frac{1}{2}$ | 2 | 102.7 | |
| 12SC | 7 | 12SC70 | 12H* | 2 $\frac{1}{8}$ | | | | | |
| | | 12SC70-14 | 14H | 3 $\frac{1}{8}$ | | | | | |
| | 7 $\frac{1}{2}$ | 12SC78 | 12H* | 2 $\frac{1}{8}$ | | | | | |
| | 12SC78-14 | 14H | 3 $\frac{1}{8}$ | | | | | | |
| | 12SC100-14 | 14H | 3 $\frac{1}{8}$ | | | | | | |
| 13SC | 7 $\frac{1}{2}$ | 13SC78 | 13H* | 3 $\frac{1}{8}$ | | | | | |
| 14SC | 7 $\frac{1}{2}$ | 14SC78 | 14H | 3 $\frac{1}{8}$ | | | | | |

Goulds Serial # 786D828-1-2
 Cust: OHM REMEDIATION SERVICES CORP.
 P.O. # 1005430
 Item # P-110A/B PROJ. CAMP LEJEUNE
 Service: STRIPPER FBED PUMPS

*Short (HS) hub also available. ■ Approximate weight for completely assembled spacer coupling.
 (1) 4JSC35 x 1 $\frac{1}{2}$ has shallow keyseat. (2) "L" dimension and weight will change if one or two short (HS) hubs used.
 Note: Refer to page 19 to order — specify components separately.

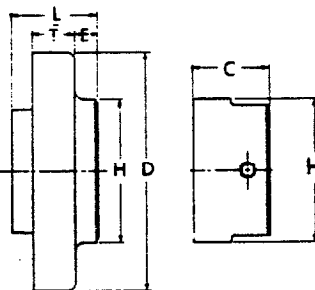
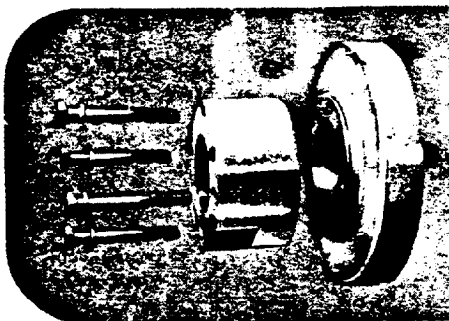

TYPE SC FLANGES AND HUBS

Tables on page 19 provide dimensional information for flanges and hubs used for Spacer Couplings. For assembled dimensions, see table above. Any of the sleeves shown on page 10 may be used.



GOULDS PUMPS, INC.
INDUSTRIAL PRODUCTS GROUP

Engineering Document Package

Goulds Serial # 786D829-1-2
Cust: OHM REMEDIATION SERVICES CORP.
P.O. # 1005430
Item # P-220A/B PROJ. CAMP LEJEUNE
Service: GAC FEED PUMPS

SUBMITTAL REVIEW

REVIEW IS FOR GENERAL COMPLIANCE
WITH CONTRACT DOCUMENTS
NO RESPONSIBILITY IS ASSUMED FOR
CORRECTNESS OF DIMENSIONS OR DETAILS.
THE CONTRACTOR/SUPPLIER SHALL ASSUME
FULL RESPONSIBILITY FOR DEVIATIONS FROM
CONTRACT REQUIREMENTS NOT SPECIFICALLY
INDICATED ON THIS SUBMITTAL.

- NO EXCEPTIONS MAKE CORRECTIONS NOTED
 AMEND AND RESUBMIT REJECTED - SEE REMARKS

Date 6-21-95

By



OHM REMEDIATION
SERVICES CORP.
NORCROSS, GEORGIA



GOULDS PUMPS, INC.
INDUSTRIAL PRODUCTS GROUP



GOULDS PUMPS, INC.

INDUSTRIAL PRODUCTS GROUP
ENGINEERED PRODUCTS DIV.

PUMP OUTLINE DRAWING
MODEL 3196 MTX, LTX

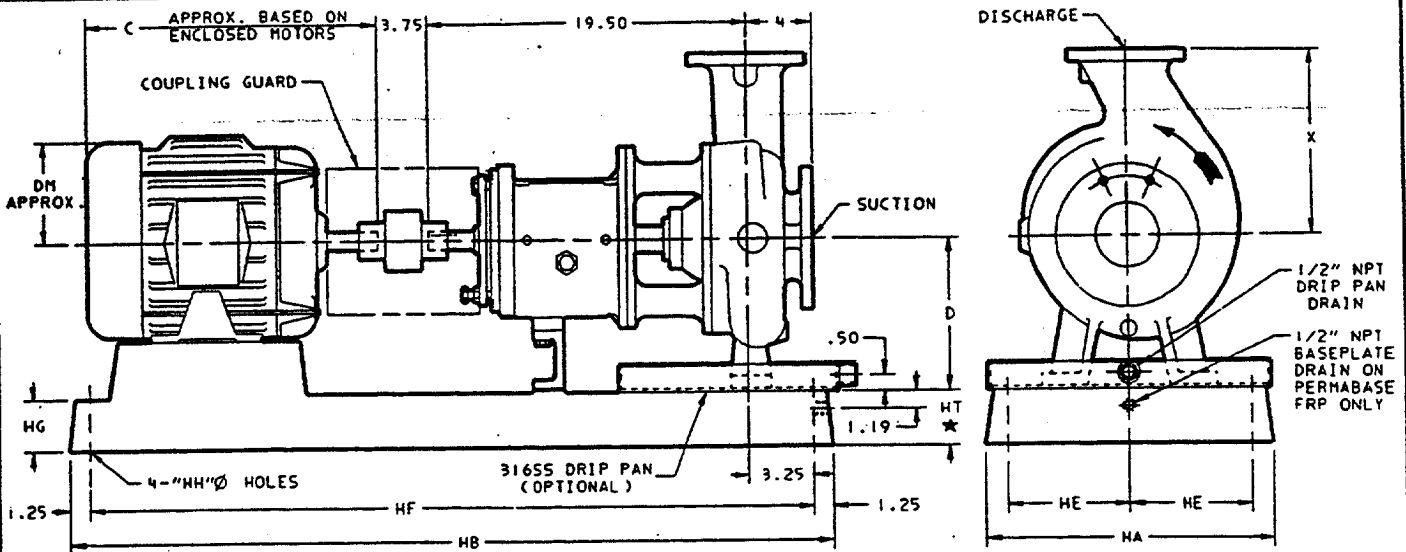

MOTOR DIMENSIONS (TEFC)

| MOTORS | | C | DM | WT. INCL. CPLG. | BASE NO. |
|--------|------|----|----|-----------------|----------|
| NEMA | IEC | | | | |
| 56 | 80 | 11 | 4 | 35 | 1 |
| 143T | 90S | 13 | 4 | 40 | 1 |
| 145T | 90L | 14 | 4 | 45 | 1 |
| 182T | 100L | 15 | 5 | 65 | 1 |
| 184T | 112M | 16 | 5 | 75 | 1 |
| 213T | 132S | 18 | 6 | 150 | 1 |
| 215T | 132M | 20 | 6 | 160 | 1 |
| 254T | 160M | 23 | 7 | 255 | 2 |
| 256T | 160L | 24 | 7 | 280 | 2 |
| 284T | 180M | 26 | 8 | 375 | 2 |
| 284TS | ---- | 25 | 8 | 345 | 2 |
| 286T | 180L | 27 | 8 | 430 | 2 |
| 286TS | ---- | 26 | 8 | 380 | 2 |
| 324T | 200M | 29 | 9 | 575 | 3 |
| 324TS | ---- | 27 | 9 | 485 | 3 |
| 326T | 200L | 30 | 9 | 640 | 3 |
| 326TS | ---- | 29 | 9 | 570 | 3 |
| 364T | 225S | 33 | 10 | 810 | 3A |
| 364TS | ---- | 31 | 10 | 755 | 3A |
| 365T | 225M | 34 | 10 | 950 | 3A |
| 365TS | ---- | 32 | 10 | 865 | 3A |
| 404TS | ---- | 34 | 11 | 1080 | 4 |
| 405TS | ---- | 36 | 11 | 1110 | 4 |
| 444TS | ---- | 39 | 13 | 1510 | 4A |

BASEPLATE DIMENSIONS

| NO. | HA | HB | HT (D=8.25) | | HT (D=10) | | HG | | HE | HF | HH | WEIGHT | |
|-----|----|----|-------------|------|-----------|------|-----------|------|------|-------|------|-----------|-----|
| | | | CAST IRON | FRP | CAST IRON | FRP | CAST IRON | FRP | | | | CAST IRON | FRP |
| 1 | 12 | 45 | 3.81 | 3.94 | 3.81 | 3.94 | 3.75 | 3.62 | 4.50 | 42.50 | .75 | 105 | 44 |
| 2 | 15 | 52 | 4.19 | 4.31 | 4.19 | 4.31 | 4.12 | 4.00 | 6.00 | 49.50 | .75 | 155 | 56 |
| 3 | 18 | 58 | 4.81 | 5.06 | 4.81 | 5.06 | 4.75 | 4.75 | 7.50 | 55.50 | 1.00 | 205 | 77 |
| 3A | 18 | 58 | 5.81 | 6.06 | 4.81 | 5.06 | 4.75 | 4.75 | 7.50 | 55.50 | 1.00 | 205 | 77 |
| 4 | 18 | 60 | 6.81 | NA | 5.06 | NA | 4.75 | NA | 7.50 | 57.50 | 1.00 | 240 | NA |
| 4A | 18 | 60 | 7.81 | NA | 6.06 | NA | 4.75 | NA | 7.50 | 57.50 | 1.00 | 240 | NA |

PUMP DIMENSIONS

| ANSI NO. | DISCH. SIZE | SUCT. SIZE | CAS'G CLASS | D | X | WGT. |
|----------|-------------|------------|-------------|-------|-------|------|
| A70 | 3 | 4 | 7 | 8.25 | 11.00 | 240 |
| A60 | 2 | 3 | 8 | 8.25 | 9.50 | 220 |
| A70 | 3 | 4 | 8G | 8.25 | 11.00 | 240 |
| A70 | 3 | 4 | 8 | 8.25 | 11.00 | 240 |
| A05 | 1 | 2 | 10 | 8.25 | 8.50 | 220 |
| A50 | 1 1/2 | 3 | 10 | 8.25 | 8.50 | 240 |
| A60 | 2 | 3 | 10 | 8.25 | 9.50 | 250 |
| A70 | 3 | 4 | 10 | 8.25 | 11.00 | 285 |
| A40 | 3 | 4 | 10H | 10.00 | 12.50 | 295 |
| A80 | 4 | 6 | 10 | 10.00 | 13.50 | 325 |
| A70 | 4 | 6 | 10H | 10.00 | 13.50 | 336 |
| A20 | 1 1/2 | 3 | 13 | 10.00 | 10.50 | 265 |
| A30 | 2 | 3 | 13 | 10.00 | 11.50 | 295 |
| A40 | 3 | 4 | 13 | 10.00 | 12.50 | 350 |
| A80 | 4 | 6 | 13 | 10.00 | 13.50 | 425 |

| PUMP MODEL |
|--|
| <input checked="" type="checkbox"/> 3196 MTX |
| <input type="checkbox"/> 3196 LTX |

| AVAILABLE OPTIONS |
|---|
| BASEPLATE: |
| <input checked="" type="checkbox"/> CAST IRON |
| <input type="checkbox"/> PERMABASE™ FRP |
| <input type="checkbox"/> Y-BASE™ |

| 31655 DRIP PAN: |
|---|
| <input type="checkbox"/> FURNISHED |
| <input checked="" type="checkbox"/> NOT FURNISHED |

| FLANGES: |
|---|
| <input checked="" type="checkbox"/> 150M ANSI FLAT FACE |
| <input type="checkbox"/> 150M ANSI RAISED FACE |
| <input type="checkbox"/> 300M ANSI FLAT FACE |
| <input type="checkbox"/> 300M ANSI RAISED FACE |

| CPLG. GUARD FURNISHED BY: |
|--|
| <input checked="" type="checkbox"/> GOULDS |
| <input type="checkbox"/> OTHERS |

INSTALL FOUNDATION IN PIPE SLEEVES. ALLOW .75 TO 1.50 FOR GROUTING. SEE INSTRUCTION BOOK FOR DETAILS.

- ◆ SUCTION FLANGE HAS (8) 3/4-10 UNC TAPPED HOLES FOR 300M CASING ONLY.
- SUCTION FLANGE HAS (8) 3/4-10 UNC TAPPED HOLES FOR 150M CASING. (12) 3/4 10 UNC TAPPED HOLES FOR 300M CASING.
- ◆ FOR 3196 LTX, ADD 20 LBS. TO PUMP WEIGHT GIVEN.
- ★ TOLERANCE IS +0 -.50 FOR CAST IRON BASEPLATE.

FOR TAPPED OPENINGS REFER TO DRAWING A04196A

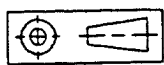

CERTIFIED FOR CONSTRUCTION PURPOSES ONLY WHEN SIGNED.

SIGNATURE *Joyce Sutterby* DATE 6-8-95

Goolds Serial # 786D829-1-2
Cust: OHM REMEDIATION SERVICES CORP.
P.O. # 1005430
Item # P-220A/B PROJ. CAMP LEJEUNE
Service: GAC FBED PUMPS

| | | | | | |
|-------|--|--------------------------|--------------------|---------------|------------|
| ISSUE | DRAWING IS NOT TO SCALE DIMENSIONS IN INCHES WEIGHTS (LBS) ARE APPROXIMATE | DRAWN DDT 08-14-92 | DRAWING A04487A | REVISION 0 | ISSUE 0 |
| | | APPROVED PTH 05-14-93 | | | |

| TAPPED OPENINGS | | | | | | | | | | | |
|-----------------|------|------|-----------------------|-----------|----|-----|------|------|-------------------------|-----------|----|
| NO. | SIZE | QTY. | PURPOSE | FURNISHED | | NO. | SIZE | QTY. | PURPOSE | FURNISHED | |
| | | | | YES | NO | | | | | YES | NO |
| TB | 1/2 | 1 | CASING DRAIN | X | | TL1 | --- | 2 | FRAME COOLER ACCESS | X | |
| TC | 1/2 | 1 | BY-PASS CONNECTION | | X | TN | 1/4 | 4 | GREASE FITTING | X | |
| TD | 3/8 | 1 | DISCHARGE GAUGE CONN. | X | | TN2 | 1/4 | 2 | OIL MIST INJECTION PORT | X | |
| TE | 3/8 | 1 | SUCTION GAUGE CONN. | | | TY | 1/2 | 1 | OIL FILL | X | |
| TF | 3/8 | 1 | BEARING FRAME DRAIN | X | | TZ | 1/4 | 1 | BOTTLE OILER CONNECTION | X | |
| TL | 1/2 | 2 | FRAME COOLING CONN. | | X | | | | | | |

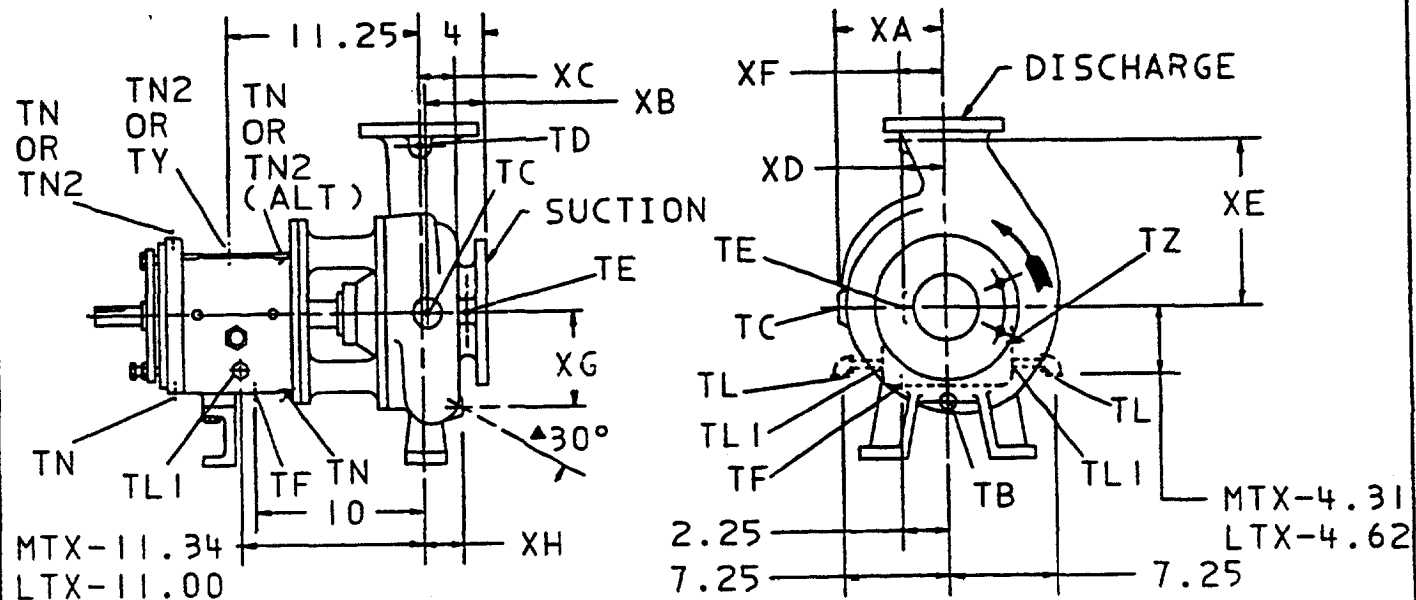

| PUMP DIMENSIONS | | | | | | | | | |
|-----------------|------------|------|------|------|------|-------|------|------|------|
| ANSI NO. | SIZE | XA | XB | XC | XD | XE | XF | XG | XH |
| A70 | 3X4-7 | 5.88 | 3.81 | NA | NA | 9.12 | 2.12 | 5.75 | 1.75 |
| A60 | 2X3-8 | 5.88 | 3.81 | 2.38 | 2.00 | 8.00 | 1.50 | 4.62 | 1.44 |
| A70 | 3X4-8G | 5.88 | 3.69 | 2.38 | 2.62 | 9.31 | 2.06 | 5.12 | 1.81 |
| A70 | 3X4-8 | 6.12 | 3.38 | 2.62 | 2.75 | 9.12 | 2.12 | 5.88 | 2.38 |
| A05 | 1X2-10 | 6.00 | 4.12 | 2.38 | 1.75 | 7.25 | 1.00 | 5.38 | 1.00 |
| A50 | 1 1/2X3-10 | 6.75 | 4.25 | 2.38 | 2.38 | 7.19 | 1.00 | 5.81 | 1.03 |
| A60 | 2X3-10 | 6.75 | 4.12 | 2.38 | 2.38 | 7.88 | 1.31 | 5.56 | 1.12 |
| A70 | 3X4-10 | 6.75 | 4.00 | 2.38 | 2.62 | 9.12 | 1.75 | 5.88 | 1.50 |
| X A40 | 3X4-10H | 7.62 | 4.00 | NA | NA | 10.62 | 2.12 | 6.88 | 1.88 |
| A80 | 4X6-10 | 6.88 | 3.56 | NA | NA | 11.38 | 2.44 | 7.25 | 2.50 |
| A70 | 4X6-10H | 7.94 | 4.00 | NA | NA | 11.38 | 2.50 | 7.62 | 3.34 |
| A20 | 1 1/2X3-13 | 8.25 | 4.25 | 2.25 | 2.06 | 8.94 | 1.25 | 7.19 | 1.38 |
| A30 | 2X3-13 | 8.25 | 4.12 | 2.38 | 2.19 | 9.88 | 1.50 | 7.44 | 1.94 |
| A40 | 3X4-13 | 8.50 | 4.00 | 2.62 | 2.62 | 10.62 | 2.12 | 7.88 | 1.69 |
| A80 | 4X6-13 | 8.69 | 3.88 | NA | NA | 11.38 | 2.50 | 8.38 | 2.62 |

- XD=2.38 FOR 300# CASING.
- XB=3.25 FOR 300# CASING.
- ▲30° ON SIZE 2X3-6, 3X4-7, & 4X6-10 ONLY. ALL OTHERS ARE HORIZONTAL.

PUMP MODEL

3196 MTX

3196 LTX

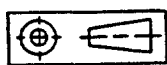

CERTIFIED FOR CONSTRUCTION PURPOSES ONLY WHEN SIGNED.

SIGNATURE *James Sutterby* DATE 6-8-95

Goulds Serial # 786D829-1-2
Cust: OHM REMEDIATION SERVICES CORP.
P.O. # 1005430
Item # P-220A/B PROJ. CAMP LEJEUNE
Service: GAC FBED PUMPS

| | | | | | |
|-------|---|-------------------------|--------------------|---------------|------------|
| ISSUE | DRAWING IS NOT TO SCALE DIMENSIONS IN INCHES | DRAWN DDT 3-25-91 | DRAWING A04196A | REVISION 3 | ISSUE 0 |
| | | APPROVED RAS 6-24-91 | | | |



GOULDS PUMPS, INC.

INDUSTRIAL PRODUCTS GROUP
ENGINEERED PRODUCTS DIV.

PUMP TAPPED OPENINGS
GROUP-MTX/LTX

STUFFING BOX/SEAL CHAMBERS/DYNAMIC SEAL

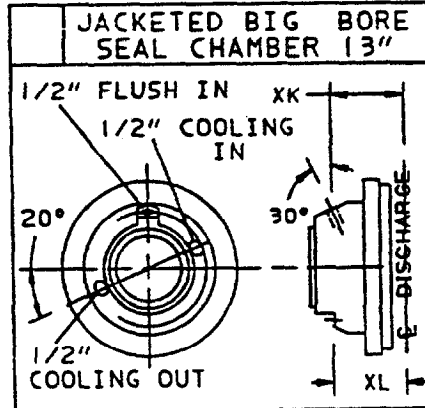
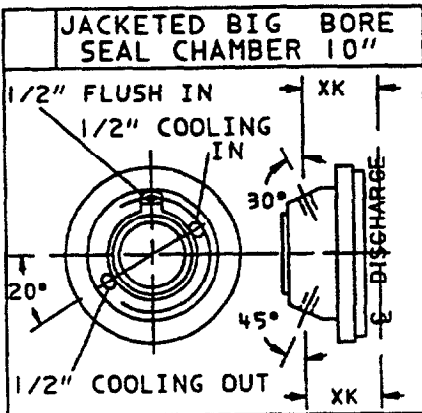
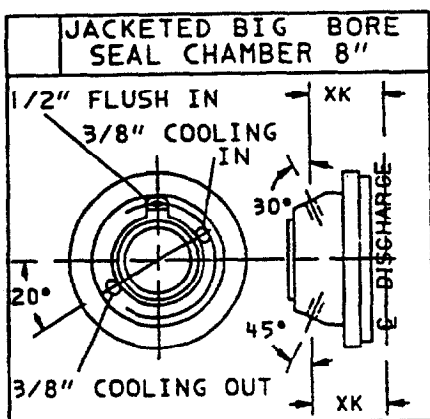
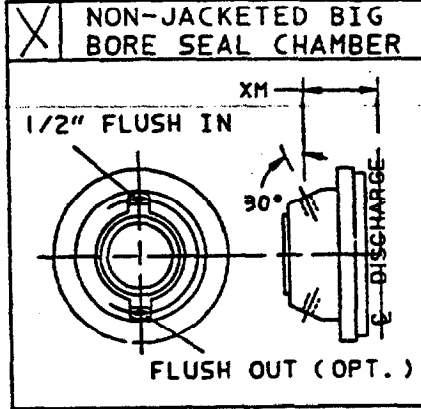
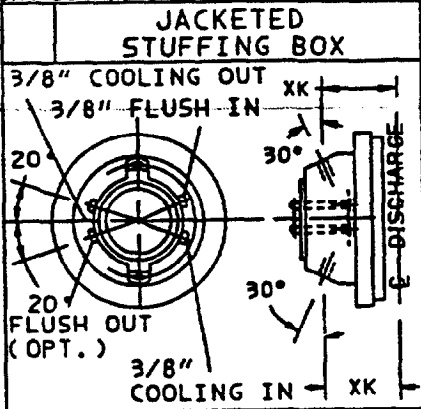
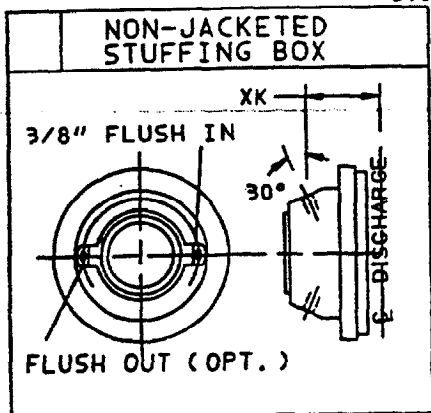

| PUMP DIMENSIONS | | | | |
|--|-------|-----------|-------|-------|
| PUMP MODEL | XK | (MAXIMUM) | | XM |
| | | XJ | XL | |
| <input checked="" type="checkbox"/> 3196 | 3.38 | 2.50 | 3.06 | 3.50 |
| <input type="checkbox"/> 3796: 2X2-10 | 5.50 | 4.81 | 5.19 | 5.62 |
| <input type="checkbox"/> 3X3-10 | 6.38 | 5.69 | 6.06 | 6.50 |
| <input type="checkbox"/> 4X4-10 | 7.12 | 6.44 | 6.81 | 7.25 |
| <input type="checkbox"/> 3X3-13 | 6.38 | 5.69 | 6.06 | 6.50 |
| <input type="checkbox"/> 4X4-13 | 7.12 | 6.44 | 6.81 | 7.25 |
| <input type="checkbox"/> 6X6-13 | 11.50 | 10.81 | 11.19 | 11.62 |
| <input type="checkbox"/> 3996 | 3.88 | 3.00 | 3.56 | 4.00 |
| <input type="checkbox"/> LF 3196 | 3.38 | 2.50 | 3.06 | 3.50 |
| <input type="checkbox"/> CV 3196: 2X2-10 | 5.50 | 4.81 | 5.38 | 5.62 |
| <input type="checkbox"/> 3X3-10 | 6.19 | 5.69 | 6.06 | 6.31 |
| <input type="checkbox"/> 2X3-13 | 6.00 | 5.69 | 5.88 | 6.19 |
| <input type="checkbox"/> 3X4-13 | 6.50 | 6.44 | 6.06 | 6.69 |

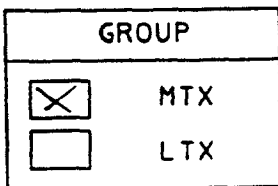
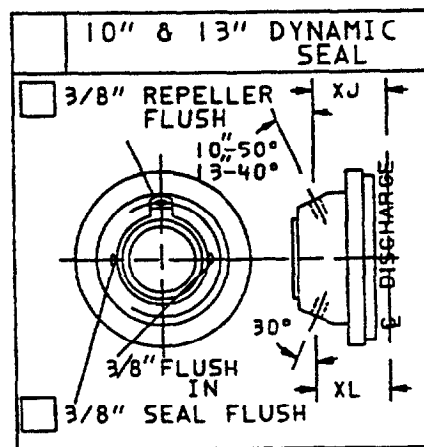

NOTE: TAPPED OPENINGS NOT AVAILABLE ON TAPER BORE™ PLUS SEAL CHAMBERS

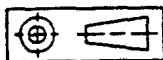

8" DYNAMIC SEAL IS NOT AVAILABLE

CERTIFIED FOR CONSTRUCTION PURPOSES ONLY WHEN SIGNED.

SIGNATURE *Joyce Sutherland* DATE 10-8-95

Goolds Serial # 786D829-1-2
Cust: OHM REMEDIATION SERVICES CORP.
P.O. # 1005430
Item # P-220A/B PROJ. CAMP LEJBUNE
Service: GAC P&B PUMPS

| | | | | | |
|-------|---|------------------------|--------------------|---------------|------------|
| ISSUE | DRAWING IS NOT TO SCALE DIMENSIONS IN INCHES | DRAWN TJA 8-31-94 | DRAWING A05461A | REVISION 0 | ISSUE 0 |
| | | APPROVED PTH 9-6-94 | | | |

**STUFFING BOX/SEAL CHAMBER GLAND OPTIONS
OPTION FURNISHED WHEN CHECKED**

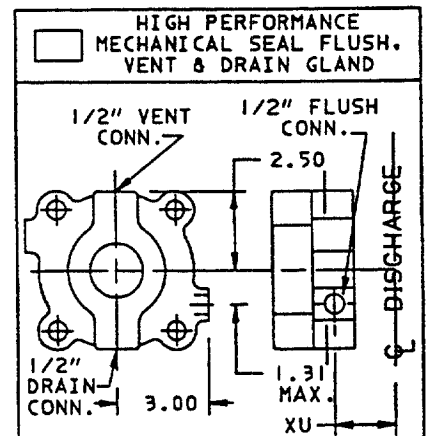
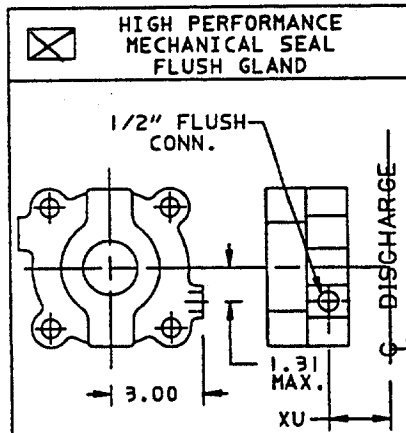
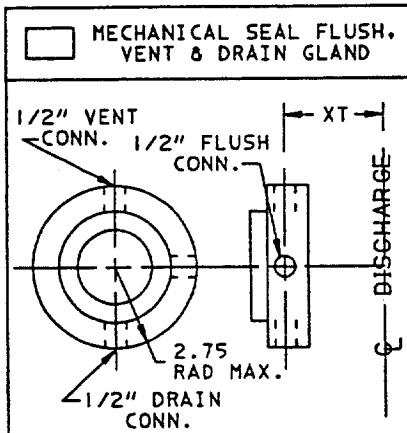
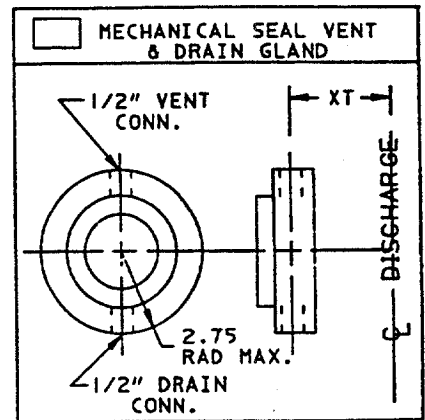
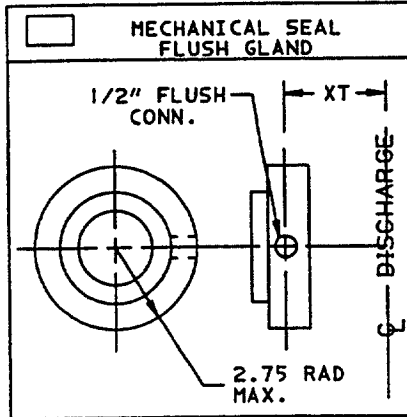
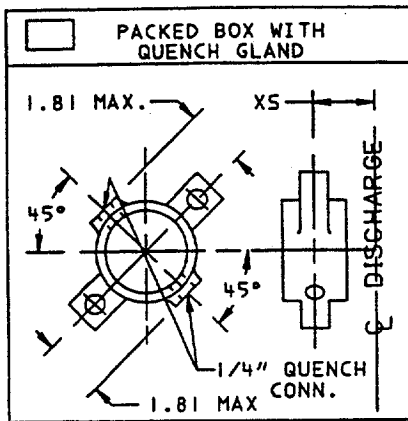

| PUMP MODEL | PUMP DIMENSIONS (MAXIMUM) | | |
|--|------------------------------|-------|-------|
| | XS | XT | XU |
| <input checked="" type="checkbox"/> 3196 | 4.88 | 4.75 | 4.62 |
| <input type="checkbox"/> 3796: | | | |
| 2X2-10 | 7.12 | 7.00 | 6.81 |
| 3X3-10 | 8.00 | 7.88 | 7.69 |
| 4X4-10 | 8.75 | 8.62 | 8.44 |
| 3X3-13 | 8.00 | 7.88 | 7.69 |
| 4X4-13 | 8.75 | 8.62 | 8.44 |
| 6X6-13 | 13.12 | 13.00 | 12.81 |
| 3996 | 5.38 | 5.25 | 5.12 |
| LF 3196 | 4.88 | 4.75 | 4.62 |
| CV 3196: | | | |
| 2X2-10 | 7.12 | 7.00 | 6.81 |
| 3X3-10 | 7.81 | 7.69 | 7.52 |
| 2X3-13 | 7.69 | 7.56 | 7.36 |
| 3X4-13 | 8.19 | 8.06 | 7.86 |

| GROUP | |
|-------------------------------------|-----|
| <input checked="" type="checkbox"/> | MTX |
| <input type="checkbox"/> | LTX |

CERTIFIED FOR CONSTRUCTION PURPOSES ONLY WHEN SIGNED.

SIGNATURE *Joyce Sutterley* DATE 6-8-95

Goolds Serial # 786D829-1-2
Cust: OHM REMEDIATION SERVICES CORP.
P.O. # 1005430
Item # P-220A/B PROJ. CAMP LBIBUNE
Service: GAC FBED PUMPS

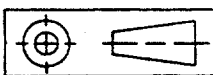

ISSUE

DRAWING IS NOT TO SCALE
DIMENSIONS IN INCHES

DRAWN TJA
09-01-94
CHECKED PTM
09-06-94

DRAWING
A05469A

REVISION
0

ISSUE
0

DATE 2-26-81

REV. DATE 3-29-93 ISSUE #1
1-30-91 ISSUE #2
1-8-87 ISSUE #2
10-8-82 ISSUE #1

GOULDS PUMPS, INC.
SENECA FALLS, NEW YORK 13148

CENTRIFUGAL PUMP CHARACTERISTICS

RPM 1750 CDS 2929-4

MODEL 3196

SIZE 3X4-10H

IMP. DWG. C00262A01 C00262A02

PATTERN 58009 58434

EYE AREA 17.5 in²

10" IMP. DIA.

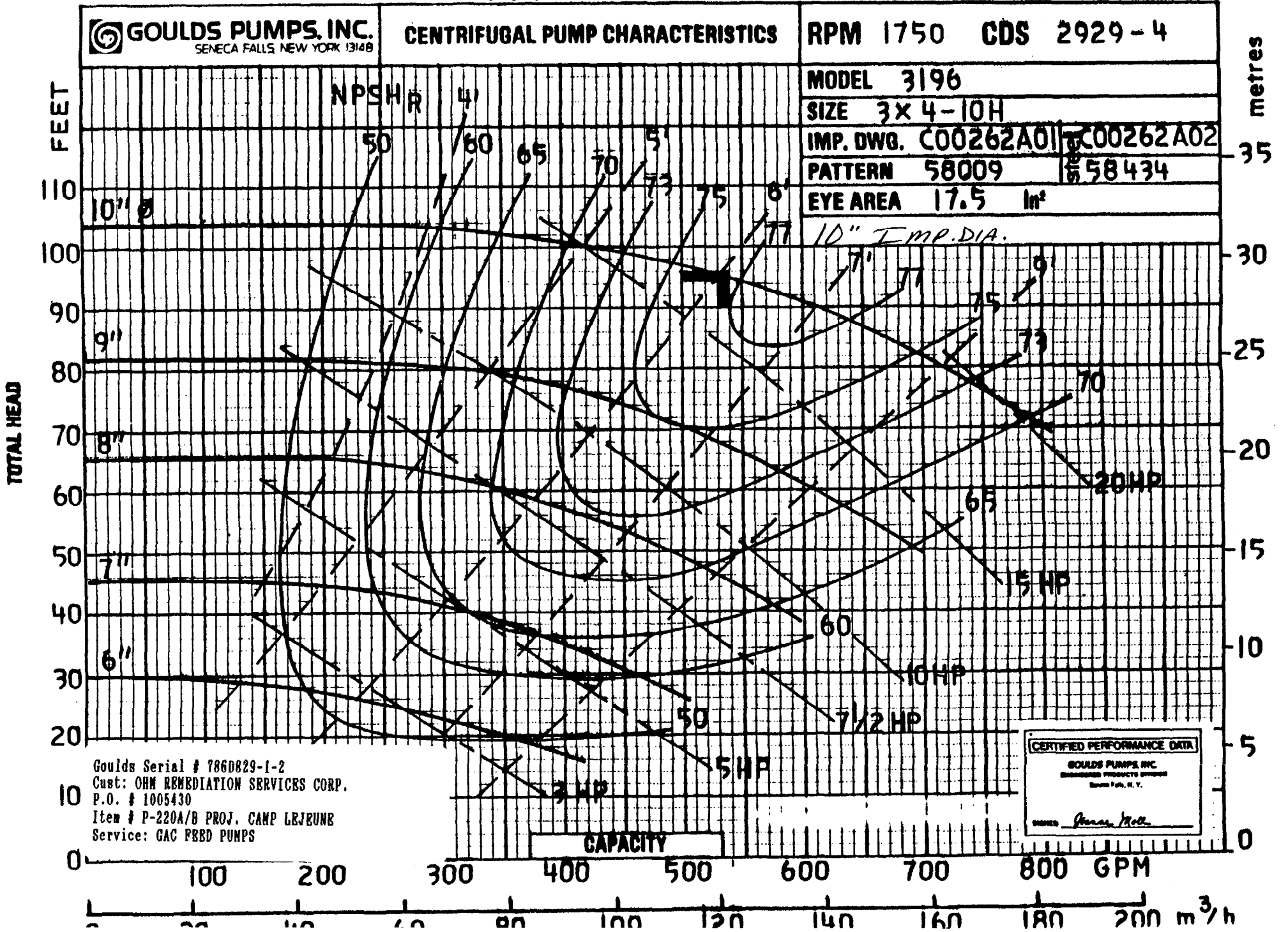

metres

TOTAL HEAD

Goolds Serial # 786D829-1-2
Cust: OHM REMEDIATION SERVICES CORP.
P.O. # 1005430
Item # P-220A/B PROJ. CAMP LEJEUNE
Service: GAC PBBD PUMPS

CERTIFIED PERFORMANCE DATA
GOULDS PUMPS, INC.
SENECA FALLS, N. Y.
SIGNED: *James Hall*

CAPACITY

100 200 300 400 500 600 700 800 GPM

30 60 90 120 150 180 200 m³/h

B OF MATERIAL
CONSTRUCTION: DUCTILE IRON

| ITEM NO | QTY PER PUMP | PART NAME | MATERIAL |
|---------|--------------|-------------------------|-----------|
| 100 | 1 | CASING | DI |
| 101 | 1 | IMPELLER | 316SS |
| 105 | 2 | LANTERN RING HALF | TEFLON |
| 106 | 1 | STUFFING BOX PKG | NON-ASB |
| 107 | 1 | GLAND | 316SS |
| 108 | 1 | FRAME ADAPTER | DI |
| 112A | 1 | BALL BRG OTBD | STEEL |
| 113A | 1 | PLUG OIL FILL | STEEL |
| 122 | 1 | SHAFT | STEEL |
| 126 | 1 | SHAFT SLEEVE | 316SS |
| 134 | 1 | BRG HOUSING | CI |
| 136 | 1 | BRG LOCK NUT | STEEL |
| 168A | 1 | BALL BRG INBD | STEEL |
| 184 | 1 | S.B. COVER/SEAL CHAM. | DI |
| 228 | 1 | FRAME | CI |
| 241 | 1 | FRAME FOOT | CI |
| 319 | 1 | SIGHT GLASS | STL/GLASS |
| 332A | 1 | LBYR SEAL OTBD W/O-RING | TFL/GPH |
| 333A | 1 | LBYR SEAL INBD W/O-RING | TFL/GPH |
| 351 | 1 | GASKET-CASE | EPDM-RBR |
| 353 | 2 | STUD-GLAND | 316SS |
| 355 | 2 | NUT GLAND STUD | 304SS |
| 360D | 1 | GASKET-FR-ADPTR | VELLUMOID |
| 361A | 1 | RTNG RING-BRG HSG | STEEL |
| 370 | 8 | H CAP SCR-ADPTR-CASE | STEEL |
| 370B | 4 | H CAP SCR-ADPTR-FR | STEEL |
| 370C | 3 | H TAP BOLT-BRG HSG | STEEL |
| 370D | 3 | H TAP BOLT-IMPLR-ADJ | STEEL |
| 370F | 2 | H CAP SCR-FR-FOOT | STEEL |
| 370H | 2 | STUD-COVER-ADPTR | 304SS |
| 382 | 1 | BRG LOCKWASHER | STEEL |
| 400 | 1 | KEY SQUARE | STEEL |
| 408A | 1 | MAG. PLUG-OIL DRAIN | STEEL |
| 408J | 1 | PLUG SIGHT OILER | STEEL |
| 408H | 4 | PLUG OIL MIST CONN | STEEL |
| 412A | 1 | O-RING IMPELLER | TEFLON |
| 418 | 3 | H TAP BOLT-JACKING | 304SS |
| 423 | 3 | JAM NUT FOR 370D | STEEL |
| 469B | 2 | DOWEL PIN-FR-ADPTR | ALLOY-ST |
| 496 | 1 | O-RING-BRG HSG | BUNA-RBR |
| 497F | 1 | O-RING OTBD SEAL ROT. | VITON |
| 497G | 1 | O-RING OTBD SEAL STA. | VITON |
| 497H | 1 | O-RING INBD SEAL ROT. | VITON |
| 497J | 1 | O-RING INBD SEAL STA. | VITON |

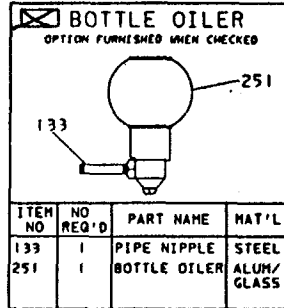

STANDARD OIL LUBE

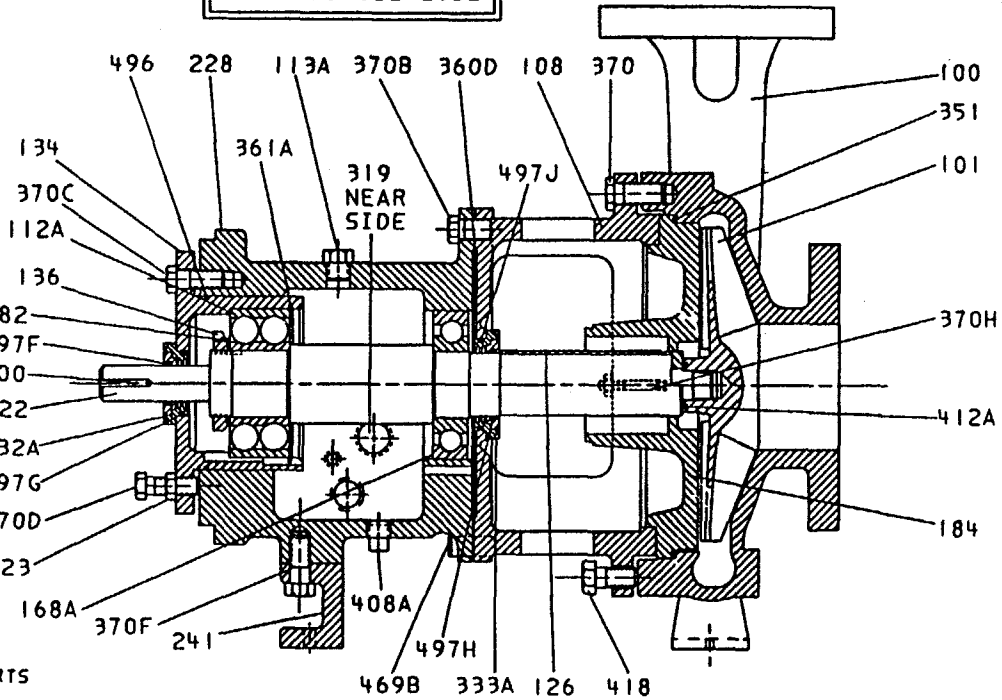

- * RECOMMENDED SPARE PARTS
- Ⓐ ITEM 370 IS QTY 12 FOR 10" CASINGS & QTY 16 FOR 13" CASINGS.
 - Ⓑ GLAND BOLTING FOR PACKING GLAND (ITEM 353 & 355) IS QTY 2. FOR MECHANICAL SEAL QTY 4.
 - Ⓒ ITEMS NOT ILLUSTRATED.

STUFFING BOX COVER / SEAL CHAMBER OPTIONS - CHECK OPTION REQUIRED

| | | | |
|--|---|--|--|
| <input type="checkbox"/> STUFFING BOX | REFER TO SEAL DRAWING NO. <u>265-248801</u> | <input checked="" type="checkbox"/> ATTACHED | <input type="checkbox"/> TO FOLLOW |
| <input type="checkbox"/> NONJACKETED (SHOWN) | <input type="checkbox"/> TAPER BORE™ PLUS | <input checked="" type="checkbox"/> BIG BORE™ STD. FLUSH | <input type="checkbox"/> BIG BORE™ W/ INTERNAL BY-PASS |
| <input type="checkbox"/> JACKETED | | <input type="checkbox"/> NONJACKETED (SHOWN) | |
| | | <input type="checkbox"/> JACKETED | |

Goulds Serial # 786D829-1-2
Cust: OHM REMEDIATION SERVICES CORP.
P.O. # 1005430
Item # P-220A/B PROJ. CAMP LRJBUNK
Service: GAC FBBD PUMPS

PUMP CROSS SECTION DRAWING
MODEL 3196MTX

GOULDS PUMPS, INC.
INDUSTRIAL PRODUCTS GROUP
ENGINEERED PRODUCTS DIV.

| | | | |
|--------------------------|----------------------------|-----------------------------|---------------------------|
| DRAWN THO 05/20/91 | CHECKED THO 05/20/91 | APPROVED RAS 06/28/91 | THIRD ANGLE PROJECTION |
| DRAWING IS NOT TO SCALE | | | REV. 2 |

B02917A2

Goulds Serial # 786D829-1-2
 Cust: OHM REMEDIATION SERVICES CORP.
 P.O. # 1005430
 Item # P-220A/B PROJ. CAMP LEJEUNE
 Service: GAC FBED PUMPS

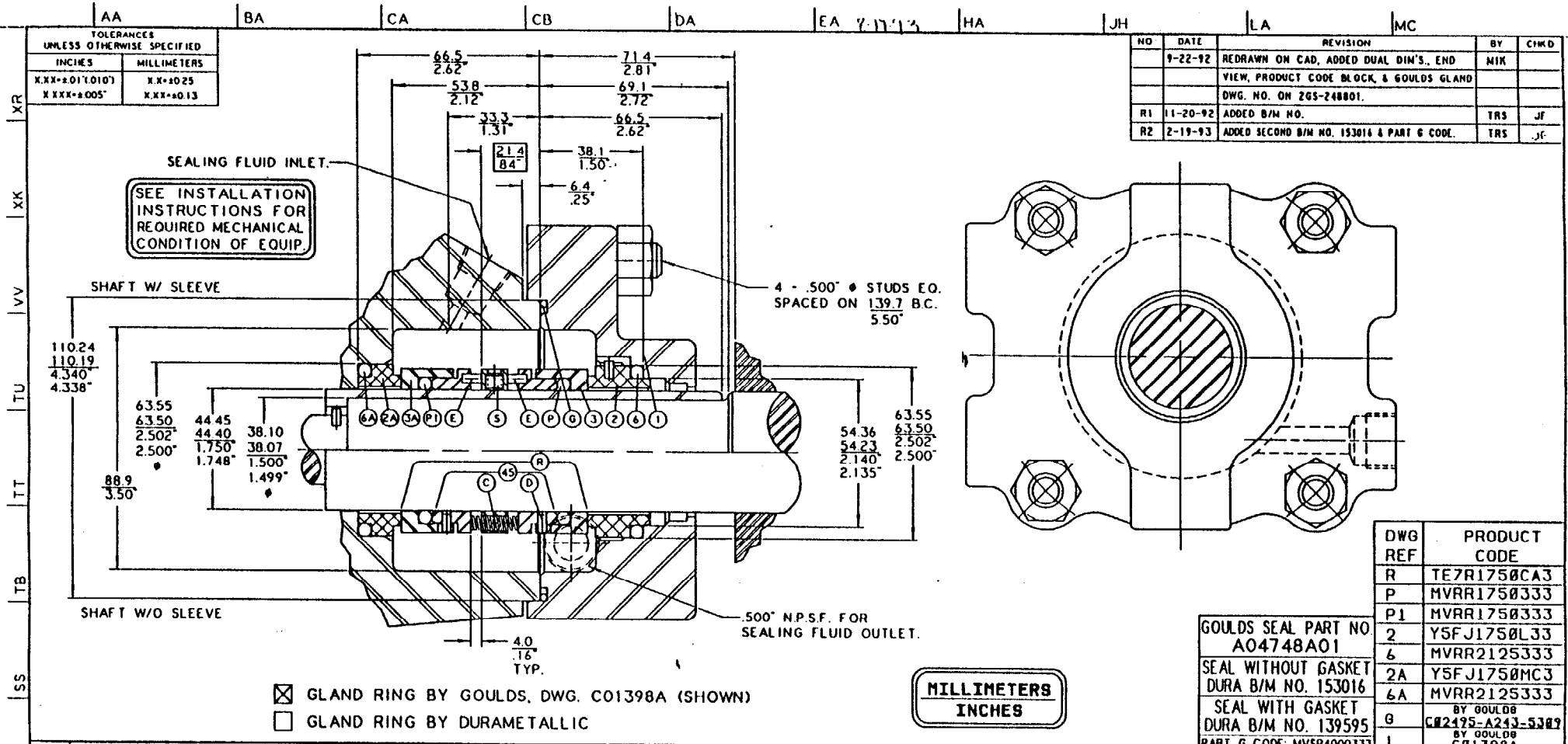

| NO | DATE | REVISION | BY | CHKD |
|----|----------|---|-----|------|
| | 9-22-92 | REDRAWN ON CAD, ADDED DUAL DIM'S., END VIEW, PRODUCT CODE BLOCK, & GOULDS GLAND DWG. NO. ON 2GS-248801. | NIK | |
| R1 | 11-20-92 | ADDED B/M NO. | TRS | JF |
| R2 | 2-19-93 | ADDED SECOND B/M NO. 153014 & PART G CODE. | TRS | JF |

| DWG REF | PRODUCT CODE |
|---------|-------------------------------|
| R | TE7R1750CA3 |
| P | MVRR1750333 |
| PI | MVRR1750333 |
| 2 | Y5FJ1750L33 |
| 6 | MVRR2125333 |
| 2A | Y5FJ1750MC3 |
| 6A | MVRR2125333 |
| G | BY GOULDS C#2495-A243-5389 |
| 1 | BY GOULDS C#1398A |

GOULDS SEAL PART NO. A04748A01
 SEAL WITHOUT GASKET DURA B/M NO. 153016
 SEAL WITH GASKET DURA B/M NO. 139595
 PART G CODE: MYSR4000333

- GLAND RING BY GOULDS, DWG. C01398A (SHOWN)
- GLAND RING BY DURAMETALLIC

MILLIMETERS
 INCHES

| RECOMMENDED SPARE PARTS: | 2, 2A, 3, 3A, 6, 6A, C, G, P, PI, S | | | | |
|--------------------------|-------------------------------------|-------------|------------|-------------|--------------|
| R | ROTARY UNIT CONSISTING OF: | P | SHAFT PKG. | VITON | |
| 3 | SEAL RING | TUNCARB62-6 | PI | SHAFT PKG. | VITON 1 |
| 3 | SEAL RING | TUNCARB62-6 | 2 | INSERT | NO. 5 CARBON |
| 45 | COMP. UNIT | 316 SS | 6 | INSERT MTG. | VITON |
| C | SPRINGS | 20 SS | 2A | INSERT | NO. 5 CARBON |
| D | DRIVE PINS | 20 SS | 6A | INSERT MTG. | VITON |
| E | SPRING PINS | 20 SS | G | GASKET | NON-ASB |
| S | SET SCREWS | 20 SS | 1 | GLAND RING | 316SS |

| | |
|--|-------------------|
| CUSTOMER: GOULDS PUMPS, INC., SENECA FALLS, NY | |
| P.O. NO: | F.O.NO: |
| USER: | |
| EQUIP. TYPE & SIZE | EQUIP. SERIAL NO. |
| GOULDS 3196 MT & MTX ANSI PLUS PUMPS | 786D829 |
| EQUIP. ITEM NO: | PRODUCT |
| REFERENCE DWG. NO. | PRESSURES |
| C01391A | BOX: |
| | SUCT.: |
| | DISCH.: |
| | TEMP: 70°F |
| | R.P.M.: 1800 |
| | SP GR: 1.00 |

| | | |
|--------------------------|---------------|-------------------|
| DURA SEAL TYPE | | SEAL SIZE |
| DOUBLE INSIDE RO | | 1.750" |
| DURAMETALLIC CORPORATION | | |
| KALAMAZOO, MICHIGAN | | |
| MATL CODE | E U 5 - - V V | ORDER PARTS BY |
| SCALE: .72"=1.00" | DATE: 4-29-89 | B/M NO: SEE ABOVE |
| DWN. TC | CHKD: GB | DATE: 9-28-92 |
| APPROBY: | DWN. PGP | CHKD: GB |
| FORM DWG: | DWG NO: | |
| 2GS-248801 | 786829#3 | |



GOULDS PUMPS, INC.
ENGINEERED PRODUCTS DIVISION

LUBRICANT DATA SHEET

CUSTOMER INFORMATION

EQUIPMENT IDENTIFICATION

Goulds Serial # 786D829-1-2
Cust: OHM REMEDIATION SERVICES CORP.
P.O. # 1005430
Item # P-220A/B PROJ. CAMP LEJEUNE
Service: GAC FEED PUMPS

MODEL 3196MTX SIZE 3X4-10H
LUBRICATION OIL
CONST. DI / 316SS

| PART LUBRICATED | LUBRICANT | | FILL CAPACITY | CONSUMPT. AMT. / TIME | RECOMMENDED LUBRICANT MFR. & NO. & REMARKS |
|-----------------------|------------------|------------|---------------------------|---|--|
| | TYPE | VISC OSITY | | | |
| BEARING HOUSING FRAME | TURBINE TYPE OIL | ISO VG68 | APPROX. 2.6 PTS (1250 ML) | REFILL AP- PROXIMATELY EVERY(3) MONTHS OR 2000 HRS. | OIL MUST BE VISIBLE AT CENTER OF SIGHT GLASS |

REV. DATE

| | | | | | |
|--|--|------------|-------------|-------------|------|
| | | WRITTEN BY | APPROVED BY | DRAWING NO. | REV. |
| | | DATE | DATE | 196 MTX LDS | 0 |

SHEET 1 OF 1



TYPE SC SPACER COUPLINGS

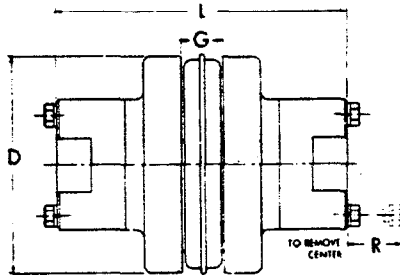
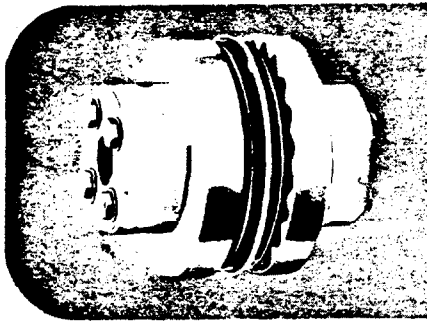

The table below shows assembled dimensions of Sure-Flex Type SC Spacer Couplings. For dimensions of separate components, refer to page 19.

| Coupling Size | Required Distance Between Shafts | Use Flange No. | Use Hub No. | Max. Bore Std. KS | Dimensions | | | | Wt. ⁽²⁾ (lbs.) |
|---------------|----------------------------------|----------------|-------------|----------------------|------------|------------------|--------|--------|---------------------------|
| | | | | | D | L ⁽¹⁾ | G | R | |
| 4JSC | 3 1/2 | 4JSC35 | | 1 1/8 ⁽¹⁾ | 2.460 | 5 1/2 | 3/8 | | 2.7 |
| 5SC | 3 1/2 | 5SC35 | 5H | 1 1/8 | 3.250 | 5 1/2 | 3/4 | 9/16 | 4.5 |
| 6SC | 3 1/2 | 6SC35 | 6H | 1 1/8 | 4.000 | 5 1/2 | 7/8 | 3/4 | 7.3 |
| | 4 1/8 | 6SC44 | 6H | 1 1/8 | 4.000 | 6 1/2 | 7/8 | 3/4 | 8.1 |
| | 5 | 6SC50 | 6H | 1 1/8 | 4.000 | 7 1/2 | 7/8 | 3/4 | 8.7 |
| 7SC | 3 1/2 | 7SC35 | 7H | 1 1/8 | 4.625 | 6 1/2 | 1 | 5/8 | 9.9 |
| | 4 3/8 | 7SC44 | 7H | 1 1/8 | 4.625 | 7 1/2 | 1 | 5/8 | 10.8 |
| | 5 | 7SC50 | 7H | 1 1/8 | 4.625 | 7 1/2 | 1 | 5/8 | 11.4 |
| 8SC | 3 1/2 | 8SC35 | 8H | 1 1/8 | 5.450 | 6 1/2 | 1 1/8 | 1 1/16 | 15.2 |
| | | 8SC35-10 | 10H* | 2 3/8 | 5.450 | 8 1/2 | 1 1/8 | 1 1/16 | 23.2 |
| | 4 3/8 | 8SC44 | 8H | 1 1/8 | 5.450 | 7 1/2 | 1 1/8 | 1 1/16 | 16.4 |
| | 5 | 8SC50 | 8H | 1 1/8 | 5.450 | 8 1/2 | 1 1/8 | 1 1/16 | 17.4 |
| | 8SC50-10 | 10H* | 2 3/8 | 5.450 | 9 1/2 | 1 1/8 | 1 1/16 | 27.2 | |
| 9SC | 3 1/2 | 9SC35 | 9H* | 2 1/8 | 6.350 | 7 1/2 | 1 1/8 | 1 1/16 | 18.6 |
| | 4 3/8 | 9SC44 | 9H* | 2 1/8 | 6.350 | 8 1/2 | 1 1/8 | 1 1/16 | 22.2 |
| | 5 | 9SC50 | 9H* | 2 1/8 | 6.350 | 8 1/2 | 1 1/8 | 1 1/16 | 23.2 |
| | | 9SC50-11 | 11H* | 2 1/8 | 6.350 | 10 1/2 | 1 1/8 | 1 1/16 | 40.4 |
| | 7 | 9SC70-11 | 11H* | 2 1/8 | 6.350 | 12 1/2 | 1 1/8 | 1 1/16 | 48.2 |
| | 9SC78-11 | 11H* | 2 1/8 | 6.350 | 13 1/2 | 1 1/8 | 1 1/16 | 51.0 | |
| 10SC | 4 3/8 | 10SC48 | 10H* | 2 3/8 | 7.500 | 9 1/2 | 1 1/2 | 1 1/16 | 37.6 |
| | 5 | 10SC50 | 10H* | 2 3/8 | 7.500 | 9 1/2 | 1 1/2 | 1 1/16 | 38.4 |
| | 7 | 10SC70-13 | 13H* | 3 1/8 | 7.500 | 13 1/2 | 1 1/2 | 1 1/8 | 72.0 |
| | 7 1/2 | 10SC78-13 | 13H* | 3 1/8 | 7.500 | 14 1/2 | 1 1/2 | 1 1/8 | 76.0 |
| 10 | 10SC100-13 | 13H* | 3 1/8 | 7.500 | 16 1/2 | 1 1/2 | 1 1/8 | 88.0 | |
| 11SC | 4 3/8 | 11SC48 | 11H* | 2 3/8 | 8.625 | 10 1/2 | 1 1/2 | 1 1/16 | 54.5 |
| | 5 | 11SC50 | 11H* | 2 3/8 | 8.625 | 10 1/2 | 1 1/2 | 1 1/16 | 54.7 |
| | 7 | 11SC70-14 | 14H | 3 1/8 | 8.625 | 14 1/2 | 1 1/2 | 2 | 86.1 |
| | 7 1/2 | 11SC78-14 | 14H | 3 1/8 | 8.625 | 15 1/2 | 1 1/2 | 2 | 90.3 |
| 10 | 11SC100-14 | 14H | 3 1/8 | 8.625 | 17 1/2 | 1 1/2 | 2 | 102.7 | |
| 12SC | 7 | 12SC70 | 12H* | 2 3/8 | | | | | |
| | | 12SC70-14 | 14H | 3 1/8 | | | | | |
| | 7 1/2 | 12SC78 | 12H* | 2 3/8 | | | | | |
| | 12SC78-14 | 14H | 3 1/8 | | | | | | |
| 10 | 12SC100-14 | 14H | 3 1/8 | | | | | | |
| 13SC | 7 1/2 | 13SC78 | 13H* | 3 1/8 | | | | | |
| 14SC | 7 1/2 | 14SC78 | 14H | 3 1/8 | | | | | |

Goulds Serial # 786D829-1-2
 Cust: OHM REMEDIATION SERVICES CORP.
 P.O. # 1005430
 Item # P-220A/B PROJ. CAMP LEJRUNE
 Service: GAC FEED PUMPS

*Short (HS) hub also available. ■ Approximate weight for completely assembled spacer coupling.
 (1) 4JSC35 x 1 1/8" has shallow keyseat. (2) "L" dimension and weight will change if one or two short (HS) hubs used.
 Note: Refer to page 19 to order — specify components separately.

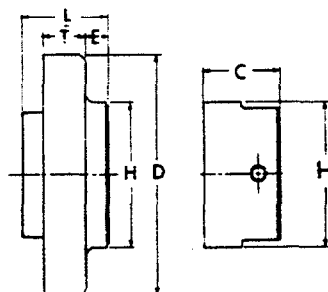
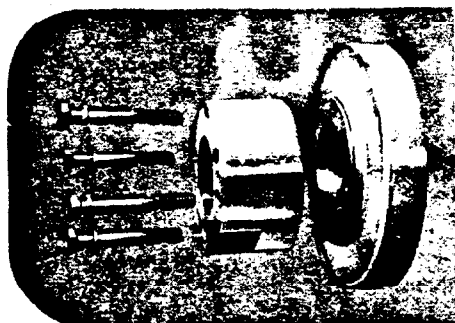

TYPE SC FLANGES AND HUBS

Tables on page 19 provide dimensional information for flanges and hubs used for Spacer Couplings. For assembled dimensions, see table above. Any of the sleeves shown on page 10 may be used.



GOULDS PUMPS, INC.
INDUSTRIAL PRODUCTS GROUP



GOULDS PUMPS, INC.

240 FALL STREET
SENECA FALLS, NY 13148 USA
PHONE: 800-446-8537
FAX: 800-423-7775
TELEX: 740 1764 SEFS UC

**TO: OHM REMEDIATION SERVICES CORP.
5335 TRIANGLE PARKWAY
SUITE 450
ATTN: BUTCH MATTHEWS
NORCROSS, GA 30092**

SUBJECT: YOUR P.O. NO. 1005442

NOVEMBER 21, 1995

THE FOLLOWING TECHNICAL DATA IS SUBMITTED FOR YOUR REVIEW (SEE BELOW):

| <u>QTY.</u> | <u>DESCRIPTION</u> | <u>DWG.NO.</u> | <u>ITEM NO.</u> | <u>GOULDS F.O. NO.</u> |
|-------------|---------------------|----------------|-----------------|------------------------|
| 1R+1P | DRIVER PRINT/WIRING | | P-145 | 786D951 |
| 1R+1P | DRIVER PERF ELEC. | | | |
| 1R+1P | DRIVER RPD'S | | | |

- PUMP INSTALLATION OPERATING AND MAINTENANCE MANUALS ATTACHED.
- 1 MOTOR INSTALLATION OPERATING AND MAINTENANCE MANUALS ATTACHED.U.S.
- YOUR COMPLETE APPROVAL REQUIRED BEFORE ORDER IS SCHEDULED AND RELEASED TO MANUFACTURING.
- THE ABOVE LITERATURE IS FOR YOUR INFORMATION AND RECORDS, AND DOES NOT REQUIRE YOUR APPROVAL. RETAIN LITERATURE AS YOUR FINAL DISTRIBUTION.

NOTE: ANY CHANGES MAY AFFECT QUOTED PRICES AND SHIPPING SCHEDULES.

**VERY TRULY YOURS,
BOB NIXON**

CC: ATLANTA-M. COMPTON

PN



GENERAL INSTALLATION, OPERATION & MAINTENANCE INSTRUCTIONS

SAFETY FIRST

High voltage and rotating parts can cause serious or fatal injury. Safe installation, operation, and maintenance must be performed by qualified personnel. Familiarization with and adherence to NEMA MG2, the National Electrical Code, and local codes is recommended. It is important to observe safety precautions to protect personnel from possible injury. Personnel should be instructed to:

1. Avoid contact with energized circuits or rotating parts.
2. Disconnect and lock out all power sources before initiating any maintenance or repair.
3. Act with care in accordance with prescribed procedures in handling and lifting this equipment.
4. Be sure unit is electrically grounded in accordance with code requirements.
5. Be sure equipment is properly enclosed to prevent access by children or other unauthorized personnel in order to prevent possible accidents.
6. Be sure shaft key is fully captive before unit is energized.
7. Avoid contact with capacitors until safe discharge procedures have been completed.
8. Most units are shipped without oil. Always be sure oil lubricated units are filled with correct oil to proper level before operating.
9. Provide proper safeguards for personnel against rotating parts and applications involving high inertia loads which can cause overspeed.
10. Avoid extended exposure to equipment with high noise levels.
11. Be familiar with the equipment and read all instructions thoroughly before installing on equipment.

INSPECTION AND HANDLING

Inspect unit to make sure no damage has occurred during shipment. Check Nameplate for correct speed, horsepower, voltage, Hertz, and phase for conformance with power supply and equipment. **WARNING:** Units should be lifted using all eyebolts or lugs if provided. These eyebolts or lugs are provided for lifting this unit only and must not be used to lift any additional weight. Lifting angle must not exceed 15° with shank of eyebolt. If not provided, eyebolts to be used must be per ASTM A489 or equivalent. All eyebolts must be securely tightened. Be careful not to touch overhead power lines with lifting equipment. Failure to observe this warning may result in serious personal injury or property damage.

STORAGE

Units should be stored indoors, in a clean, dry location. Winding should be protected from excessive moisture absorption. **NOTE:** If motors are to be stored for over one year, refer to U.S. Electrical Motors. If gear and belt transmission units are to be stored for over six months, refer to U.S. Electrical Motors.

LOCATION

Units should be located in a clean, well-ventilated area for maximum life. **WARNING:** Units should be located in a suitable enclosure to prevent access by children or other unauthorized personnel to prevent possible accidents.

MOUNTING

Mount units on a firm, flat surface sufficiently rigid to prevent vibration.

Drive belts and chains should be within recommended limits of tightness. Couplings should be properly aligned and balanced. For drive recommendations, refer to drive or equipment manufacturers or U.S. Electrical Motors. For application of drive equipment, refer to NEMA MG1.

Motors have been dynamically balanced using a half key the same length as the full key shipped with the motor. If pulley length is less than this key length, rework long key by removing one-half of excess length between pulley and end of key to maintain balance.

Do not restrict motor ventilation. Unless otherwise specified on Nameplate, motor is designed for operation in 40°C (104°F) maximum ambient temperature. **NOTE:** Motors operating under rated load and ambient conditions may feel hot when touched; this is normal and should not be cause for concern. When in doubt, measure frame temperature and confer with nearest office. Standard grease lubricated units can be operated in minimum ambient of -30°F. Special lubricants are required for temperatures outside this range.

If unit has been stored in a damp location, dry out thoroughly before operating.

WARNING: Guards should be provided for all exposed rotating parts to prevent possible personal injury. Keep fingers and foreign objects away from ventilation and other openings. Applications involving HIGH INERTIAL LOADS may damage equipment due to motor overspeed during coast down. Such applications should be referred to U.S. Electrical Motors.

CAUTION: Do not force drive coupling or other equipment onto shaft, as bearing damage may result.

POWER SUPPLY AND CONNECTIONS

The power supply must agree with values on Nameplate. Terminal voltage should not vary more than ±10% of Nameplate voltage at rated frequency. Unbalanced line voltage, even a small amount, will cause overheating. Do not exceed the continuous rated operating current on the Nameplate. Starting controls and overload protection should be properly sized in accordance with the National Electrical Code and the control manufacturer's recommendations.

Motor connections should be made by following instructions on connection diagram. Determine direction of rotation before connecting driven equipment. Note direction of rotation label if supplied. Rotation may be reversed on three phase motors by interchanging any two line connections. On two phase motors, interchange A-1 and A-2; and on single phase motors interchange leads per connection diagram on motor. Wiring of units, controls, and grounding shall be in accordance with local and National Electrical Code requirements. **WARNING:** Failure to properly ground unit may cause serious injury to personnel. Where unexpected starting could be hazardous to personnel, do not use automatic reset starting devices.

OIL LUBRICATION

Most oil lubricated units are shipped without oil. Add oil of the correct viscosity for the ambient temperature, per Nameplate on unit, to proper level.

Make certain an oil with mild EP additives is used on wormgear units.

Refer to Nameplate or Lubrication Instruction Plate for oil viscosity and oil change interval. **WARNING:** For applications in the food and drug industry (including animal food), consult the petroleum supplier for lubricants that are acceptable to the Food and Drug Administration and other governing bodies.

MAINTENANCE

Inspect units at regular intervals. Keep units clean and ventilation openings clear of dust, dirt or other debris. Lubricate units per this operating instruction folder and instruction plate on unit. Excessive lubrication may damage the unit. Do not over grease! **WARNING:** Disconnect all power sources to the unit and discharge all parts which may retain an electrical charge before attempting any maintenance or repair. Screens and covers must be maintained in place when unit is in operation. Motors for use in hazardous locations - Class I & II Installation: Repairs of these motors must be made by the manufacturer or authorized service station approved by the manufacturer and U.L. to maintain the U.L. Listing. The U.L. Listing applies to the electrical motor only and not to the belt or gear transmissions or other devices that may be connected to the motor.

VARIDRIVE® UNITS

Do not turn control wheel while unit is not operating as this may cause damage to the unit. Handwheel position is a relative speed indication only. Use direct speed sensing accessory for precise speed indication. Units equipped with electric remote speed indicator accessory are not calibrated at the factory and must be calibrated at site. Refer to calibration instructions with meter.

VARIDRIVES equipped with splined shafts require monthly lubrication for 8 hour/day service, and semi-monthly for 24 hour/day service. (For complete instructions for entire drive, refer to the lubrication instruction plate on unit.) Operate VARIDRIVE through its entire speed range weekly. **WARNING:** Do not force control wheel beyond speed limits shown on Nameplate. The mechanism and belt are designed for the rated speed and horsepower shown on the Nameplate. Operation beyond these limits may result in damage to the belt and mechanism and possible injury to personnel. The covers on the frame case must not be removed or left off while unit is in operation. Do not attempt to disassemble or repair the driven pulley discs as high spring force may be released, causing injury to personnel. Refer to authorized Service Center. Refer to VARIDRIVE Installation and Maintenance Manual for complete belt changing instructions.

For additional detailed information, request specific product installation and maintenance manual from U.S. Electrical Motors, St. Louis, MO 63136

RENEWAL PARTS AND WARRANTY SERVICE

When inquiring for renewal parts, call the U.S. Electrical Motor Service Department (Memphis, Tennessee) or Parts Stocking Distributors. For warranty service call the nearest U.S. Electrical Motors Service Station. Give them complete nameplate data including ID number, etc.

LUBRICATION INSTRUCTIONS

Some small motors have sealed-for-life bearings which require no re-lubrication. Regreaseable bearings are shipped with a high quality, wide temperature range grease in the bearings.

Motors can be regreased by stopping the motor, removing drain plug and pumping new grease into fill hole. Run motor with drain plug removed until excess grease has been discharged (min. 10 mins.). Stop motor and replace drain plug.

Units that operate at speeds greater than 1800 RPM should be lubricated on a more frequent maintenance schedule depending on duty cycle. Use a low pressure grease gun and avoid overgreasing.

| SERVICE | SUGGESTED REGREASING INTERVALS | | |
|----------------|---|------------|------------|
| | MOTOR HORSEPOWER | | |
| | UNDER 50 | 50-100 | 100 UP |
| A | 3-5 Yrs. | 2-4 Yrs. | 2 Yrs. |
| B | 2-4 Yrs. | 1-1/2 Yrs. | 1-1/2 Yrs. |
| C | 1-2 Yrs. | 1 Mo. | 6 Mos. |
| D | 4 Mos. | 4 Mos. | 3 Mos. |
| SERVICE SYMBOL | TYPE OF SERVICE | | |
| A | Infrequent operation or light duty in clean atmosphere. | | |
| B | 8-16 Hrs/Day in clean, relatively dry atmosphere. | | |
| C | 12-24 Hrs/Day, heavy duty, or if moisture is present. | | |
| D | Heavy duty in dirty, dusty locations; high ambient; moisture laden atmosphere; vibration. | | |

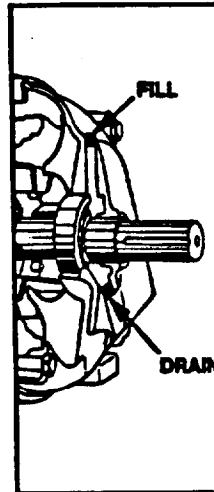

CALIFORNIA
CONNECTICUT
ILLINOIS
TENNESSEE
TENNESSEE (PARTS)
TEXAS
WORLD HEADQUARTERS
MISSOURI

OFFICES

1988 Quirdz CT., Suite A, Walnut, CA 91789(714) 594-5470
326 West Main St., Milford, CT 06460(203) 877-1762
2050 South Carboy Road, Mt. Prospect, IL 60056(312) 952-3500
845 Crossover Lane, Bldg. D, Suite 109, Memphis, TN 38117(901) 763-2400
3278 Democrat Road, Memphis, TN 38118(901) 794-5020
9535 Forest Lane, Suite 125, Dallas, TX 75243(214) 644-0470

8100 West Florissant Avenue, P.O. Box 3946, St. Louis, MO 63136(314) 553-2000

U. S. ELECTRICAL MOTORS
DIVISION OF EMERSON ELECTRIC CO.
8100 WEST FLORISSANT AVENUE
P.O. BOX 3946
ST. LOUIS, MO 63136



© 1989 U.S. Electrical Motors



| |
|--------------------|
| TO: Joyce Sutterby |
| LOC: Goulds |
| FROM: Jeff |
| LOC: USEM |

U.S. ELECTRICAL MOTORS - MOTOR PERFORMANCE 3 PHASE

USEM ORDER.: Y1560678 TYPE.: UTE FRAME: 143 HP.: 1.00
 MODEL.....: A422 POLES: 4 HZ...: 60 S.F.: 1.25
 CUSTOMER NO: 373701 VOLTS: 230 460
 NAME: Goulds Pumps CLASS OF INSULATION: F

| % RATED LOAD | PCT. EFF. | PCT. P. F. | AMPERES @ STATED VOLTS | |
|--------------|-----------|------------|------------------------|-------|
| | | | 230 V | 460 V |
| 125 | 85.5 | 82.3 | 3.3 | 1.7 |
| 100 | 86.2 | 77.8 | 2.8 | 1.4 |
| 75 | 86.0 | 70.1 | 2.3 | 1.2 |
| 50 | 83.6 | 57.3 | 2.0 | 1.0 |
| 25 | 74.9 | 37.2 | 1.7 | .8 |
| NO LOAD | | 8.7 | 1.6 | .8 |
| LOCKED ROTOR | | 61.9 | 22.9 | 11.5 |

TEMP. RISE CLASS: B

Goulds Serial # 786D951
 Cust: OHM REMEDIATION SERVICES CORP
 P.O. # 1005442
 Item # P-145 /PROJ. CAMP LEJEUNE
 Service: SUPERNATANT PUMP

NEMA NOMINAL EFF...: 86.5
 GUAR. FULL LOAD EFF: 85.6

TORQUES:
 BREAKDOWN...: 434% OF RATED LOAD TORQUE
 LOCKED ROTOR: 341% OF RATED LOAD TORQUE
 RATED LOAD...: 3.0 LB - FT.

NEMA DESIGN LETTER: B

RATED LOAD RPM.: 1743.

NEMA CODE LETTER...: L

SAFE STALL TIME: 30 SEC. (HOT)

MAX KVARS.....: .4

SOUND PRESSURE LEVEL: 59.2 DB(A)
 @ 3 FT., NO LOAD, FREE FIELD

PN: 786D951 MT1

THE ABOVE DATA IS TYPICAL, UNLESS NOTED OTHERWISE.



Title: UNIMOUNT 125 TEFC MOTOR,
PREMIUM EFFICIENCY,
DESIGN B, 40 DEG C AMBIENT
Frame: 143T
Type: UTE



USEM Model No:
A422
Customer Name:

Customer P.O.:

USEM Order No:

Certified By:

Date: 02/06/1991
HP: 1
RPM: 1800
Phase: 3
Hz: 60
Volts: 230/460
Remarks:

PN: 786D951MT1

Spare Parts

BEARINGS :
SHAFT END OPPOSITE END
6205-22-J/C3 6205-22-J/C3

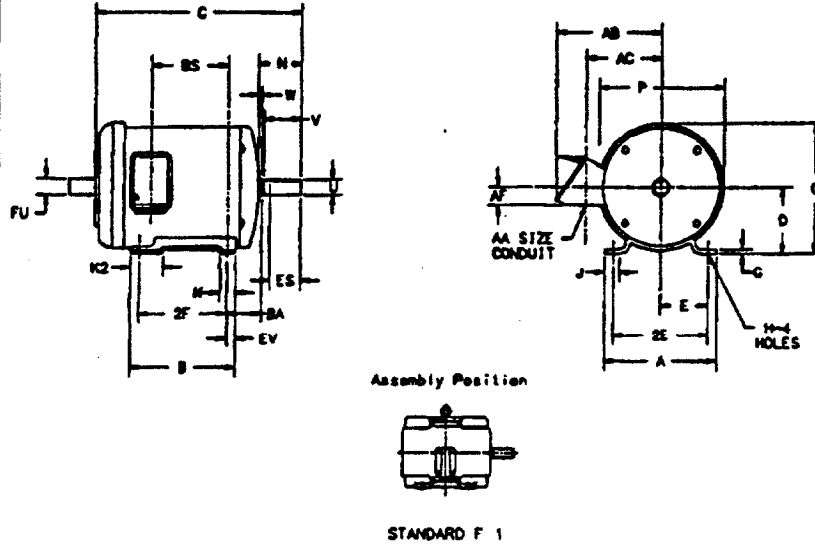

| NEMA FRAME | A | B | C | D | E | 2E | 2F | G | H | J |
|------------|-------|--------|--------|--------|----------------|---------|--------|-----|------------|---|
| 143T | 6-1/2 | 6 | 11-1/2 | 3-1/2 | 2-3/4 | 5-1/2 | 4 | 1/8 | 11/32 | 1 |
| | K | K2 | N | O | P ₀ | U | V | W | AA | |
| | 7/8 | 1-7/8 | 2-3/8 | 7-9/16 | 7-5/16 | 7/8 | 2-1/16 | 1/8 | 3/4 | |
| | AB | AC | AF | BA | BB | EB | EY | FU | SQUARE KEY | |
| | L-1/8 | 4-7/16 | 1-1/4 | 2-1/4 | 3-7/16 | 1-13/32 | 1/2 | 5/8 | 3/16 | |

* Largest Motor Width

NOTES :
Shaft extension diameter tolerance: +.0000";-.0005" up to 1-1/2" inclusive.
Larger diameters: +.000";-.001"

All rough casting dimensions may vary by 1/4" due to casting variations.

Dimension "D" will never be exceeded, but may be less than values shown. When exact dimensions are required, shims up to 1/32" may be necessary.

Goulds Serial # 786D951
Cust: OHM REMEDIATION SERVICES CORP
P.O. # 1005442
Item # P-145 /PROJ. CAMP LEJEUNE
Service: SUPERNATANT PUMP

CERTIFIED FOR:
APPROVAL RECORD

FINAL-AS BUILT

BY: DATE: 11/15/95

MOTOR WIRING DIAGRAM
3 LEAD, BLANK VOLTAGE (VYE CONN)

| VOLTAGE | L1 | L2 | L3 | TOGETHER |
|---------|---------|---------|---------|-------------------------|
| LOW | (T1,T2) | (T2,T3) | (T3,T1) | (T4, T5, T6) |
| HIGH | T1 | T2 | T3 | (T4,T5) (T5,T6) (T6,T4) |

TO REVERSE DIRECTION OF ROTATION
INTERCHANGE CONNECTIONS L1 AND L2.

EACH LEAD MAY HAVE ONE OR MORE CABLES
COMPRISING THAT LEAD IN SUCH CASE EACH
CABLE WILL BE MARKED WITH THE APPROPRIATE
LEAD NUMBER.

RENEWAL PARTS



PARTS LIST

UNIMOUNT TOTALLY ENCLOSED MOTORS

This Parts List is good for the following frames and types.

| TYPES | FRAMES |
|-----------------|--|
| UT | 50-808 143T, TC, TD, TCR 145T, TC, TD, TCR B145T, TC, TD |
| UT-1 | 143, 145, B145JP |
| UT-4 | 143, 145, B145JM |

| TYPES | FRAMES |
|----------------|--|
| UTE, UFG | 143, 145, B145T |
| UTF | 500 145TC, TD 145TC, TD |
| UTN | 143, 145T |
| UTV | 143, 145TCV, B145, JPV |
| UTW | 500 |

Goulds Serial # 786D951
 Cust: OHM REMEDIATION SERVICES CORP
 P.O. # 1005442
 Item # P-145 /PROJ. CAMP LEJEUNE
 Service: SUPERNATANT PUMP

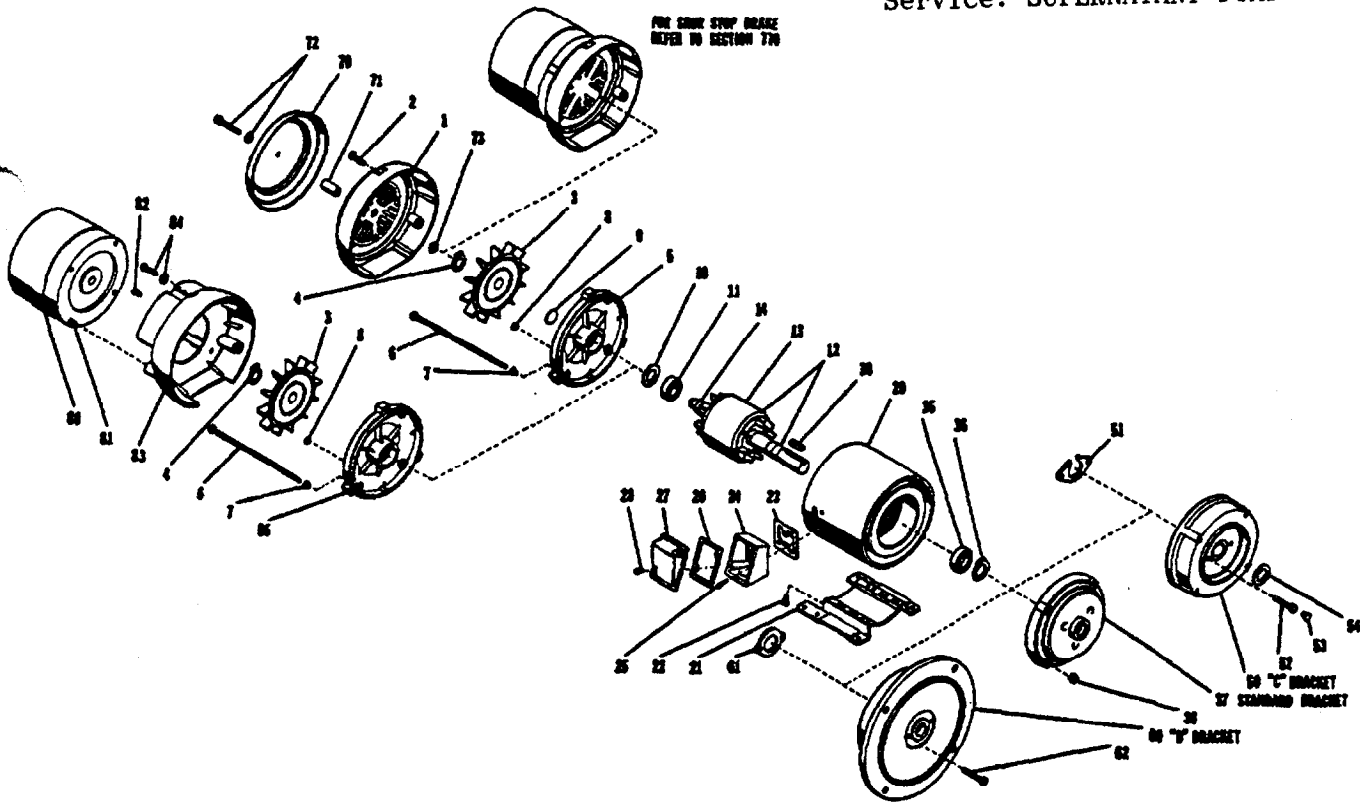

NOTICES:
 Parts stocking distributors: refer to your USEM renewal parts numerical index.
 All others: refer to your nearest USEM parts stocking distributor.



RENEWAL PARTS



PARTS LIST

UNIMOUNT TOTALLY ENCLOSED MOTORS

| ITEM NO. | QTY. | NAME OF PART |
|----------|------|--|
| 1 | 1 | Fan cover (not used on types UTN & UTFN) |
| 2 | 3 | Self tapping screw & lockwasher (not used on types UTN & UTFN) |
| 3 | 1 | Fan (fan assembly on types UTE, 3600 RPM and UTQ) (not used on types UTN & UTFN) |
| 4 | 1 | Retaining snap ring (not used on type UTE, 3600 RPM and UTN, UTQ and UTFN) |
| 5 | 1 | Bracket |
| 6 | 4 | Round head machine screw |
| 7 | 4 | Bushing |
| 8 | 4 | Plastic plug |
| 9 | 1 | Bracket plug (used on types UTN and UTFN only) |
| 10 | 1 | Spring wave washer (not used on type UTV) |
| 11 | 1 | Ball bearing |
| 12 | 1 | Rotor assembly (includes item 12 & 13) |
| 13 | 1 | Rotor core |
| 14 | 1 | Shaft |
| 15-19 | - | Not used |
| 20 | 1 | Wound stator assembly (includes items 21 and 22 if used) |
| 21 | 1 | Mounting base (not used on types UTF, UTV and UTFN) |
| 22 | 6 | Hex head cap screw (not used on types UTF, UTV and UTFN) |
| 23 | 1 | Gasket |
| 24 | 1 | Outlet box base |
| 25 | 2 | Self tapping screw |
| 26 | 1 | Gasket |
| 27 | 1 | Outlet box cover |
| 28 | 2 | Self tapping screw |
| 29-34 | - | Not used |
| 35 | 1 | Ball bearing |
| 36 | 1 | Retaining snap ring (not used on frames 56 and 56C, also types UTN and UTQ) |
| 37 | 1 | Bracket |

| ITEM NO. | QTY. | NAME OF PART |
|---|------|---|
| 38 | 4 | Hex nut |
| 39 | 1 | Sq. key |
| 40-49 | - | Not used |
| For types UT, UTF, UTV and UTFN with "C" bracket, and types UT-1 and UT-4 omit items 37, 38 and item 10 on frames 143, 145 and B145 | | |
| 50 | 1 | "C" bracket |
| 51 | 1 | Clamping plate (not used on frame 56C) |
| 52 | 2 | Hex head cap screw (not used on frame 56C) |
| 53 | 2 | Plastic plug (not used on frames 143, 145 and B145) |
| 54 | 1 | Water deflector |
| 55-59 | - | Not used |
| For types UT and UTF with "D" bracket, omit items 10, 37 and 38, and add the following parts | | |
| 60 | 1 | "D" bracket |
| 61 | 1 | Bearing cap |
| 62 | 2 | Hex head cap screw |
| 63-69 | - | Not used |
| For type UTV and units with canopy cap, add the following parts | | |
| 70 | 1 | Canopy cap |
| 71 | 1 | Spacer |
| 72 | 1 | Hex head cap screw and lockwasher |
| 73 | 1 | Square nut |
| 74-78 | - | Not used |
| For SHUR-STOP brakes, omit items 1, 3 and 4, and refer to section 770 for part addition | | |
| For Dings and Stearns brake, omit items 1, 2 and 5, and add the following | | |
| 80 | 1 | Brake (for replacement parts for brakes, refer to brake manufacturer) |
| 81 | 2 | Socket head cap screw |
| 82 | 1 | Key |
| 83 | 1 | Brake mounting bracket |
| 84 | 3 | Round head machine screw and lockwasher |
| 85 | 1 | Bracket |

Goulds Serial # 786D951
 Cust: OHM REMEDIATION SERVICES CORP
 P.O. # 1005442
 Item # P-145 /PROJ. CAMP LEJEUNE
 Service: SUPERNATANT PUMP

PRICES:

Parts stocking distributors: refer to your USEM renewal parts numerical index.
 All others: refer to your nearest USEM parts stocking distributor.



Tump T-145

Engineering Document Package

Goulds Serial # 786D951
Cust: OHM REMEDIATION SERVICES CORP
P.O. # 1005442
Item # P-145 /PROJ. CAMP LEJEUNE
Service: SUPERNATANT PUMP

SUBMITTAL REVIEW

REVIEW IS FOR GENERAL COMPLIANCE
WITH CONTRACT DOCUMENTS
NO RESPONSIBILITY IS ASSUMED FOR
CORRECTNESS OF DIMENSIONS OR DETAILS.
THE CONTRACTOR/SUPPLIER SHALL ASSUME
FULL RESPONSIBILITY FOR DEVIATIONS FROM
CONTRACT REQUIREMENTS NOT SPECIFICALLY
INDICATED ON THIS SUBMITTAL.

- | | |
|---|--|
| <input checked="" type="checkbox"/> NO EXCEPTIONS | <input type="checkbox"/> MAKE CORRECTIONS NOTED |
| <input type="checkbox"/> AMEND AND RESUBMIT | <input type="checkbox"/> REJECTED - SEE REMARKS |

Date 6-21-95 BY *B. N. [Signature]*

OHM REMEDIATION
SERVICES CORP.
NORCROSS, GEORGIA



GOULDS PUMPS, INC.
INDUSTRIAL PRODUCTS GROUP



GOULDS PUMPS, INC.

INDUSTRIAL PRODUCTS GROUP
ENGINEERED PRODUCTS DIV.

PUMP OUTLINE DRAWING
MODEL 3196 STX

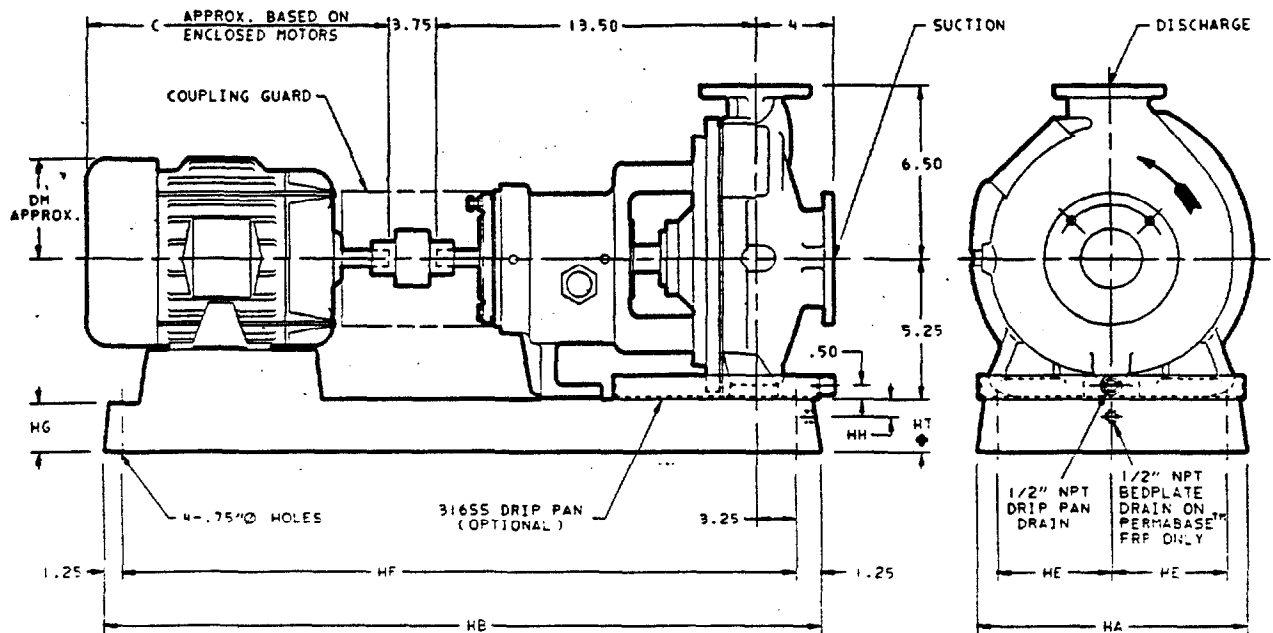

| MOTOR DIMENSIONS (TEFC) | | | | | | |
|-------------------------|------|----|----|-----------------|----------|--|
| MOTORS | | C | DM | WT. INCL. CPLG. | BASE NO. | |
| NEMA | IEC | | | | | |
| 56 | 80 | 11 | 4 | 35 | 1 | |
| 143T | 90S | 13 | 4 | 40 | 1 | |
| 145T | 90L | 14 | 4 | 45 | 1 | |
| 182T | 100L | 15 | 5 | 65 | 2 | |
| 184T | 112H | 16 | 5 | 75 | 2 | |
| 213T | 132S | 18 | 6 | 150 | 2 | |
| 215T | 132H | 20 | 6 | 160 | 2 | |
| 254T | 160H | 23 | 7 | 255 | 3 | |
| 256T | 160L | 24 | 7 | 260 | 3 | |
| 284T | 180H | 26 | 8 | 375 | 3 | |
| 284TS | ---- | 25 | 8 | 345 | 3 | |
| 286T | 180L | 27 | 8 | 430 | 3 | |
| 286TS | ---- | 26 | 8 | 360 | 3 | |

| BASEPLATE DIMENSIONS | | | | | | | | | | | | |
|----------------------|----|----|-----------|------|-----------|------|------|-------|------|-----|-----------|-----|
| NO. | HA | HB | HT | | HG | | HE | HF | HH | HT | WEIGHT | |
| | | | CAST IRON | FRP | CAST IRON | FRP | | | | | CAST IRON | FRP |
| 1 | 10 | 35 | 3.06 | 3.19 | 2.69 | 3.00 | 4.00 | 32.50 | 1.19 | 75 | 22 | |
| 2 | 12 | 39 | 3.31 | 3.69 | 3.06 | 3.12 | 4.50 | 36.50 | 1.36 | 60 | 29 | |
| 3 | 15 | 46 | 5.94 | 5.94 | 4.12 | 4.00 | 6.00 | 43.50 | 1.44 | 120 | 52 | |

| PUMP SIZE | | | |
|----------------|--------------|--------------|--------|
| DISCHARGE SIZE | SUCTION SIZE | CASING CLASS | WEIGHT |
| 1 | 1 1/2 | 6 | 84 |
| 1 1/2 | 3 | 6 | 92 |
| 2 | 3 | 6 | 95 |
| 1 | 1 1/2 | 8 | 100 |
| 1 1/2 | 3 | 8 | 106 |

| AVAILABLE OPTIONS | |
|--------------------------|---|
| BASEPLATE | <input checked="" type="checkbox"/> CAST IRON <input type="checkbox"/> PERMABASE™ FRP |
| 316SS DRIP PAN | <input checked="" type="checkbox"/> FURNISHED <input type="checkbox"/> NOT FURNISHED |
| FLANGES | <input checked="" type="checkbox"/> 150# ANSI FLAT FACE <input type="checkbox"/> 150# ANSI RAISED FACE <input type="checkbox"/> 300# ANSI FLAT FACE <input type="checkbox"/> 300# ANSI RAISED FACE |
| CPLG. GUARD FURNISHED BY | <input checked="" type="checkbox"/> GOULDS <input type="checkbox"/> OTHERS |

◆ TOLERANCE IS +0 -.50 FOR CAST IRON BASEPLATE.

■ WHEN 300# FLANGES ARE FURNISHED, DISCHARGE FLANGE WILL BE THREADED. AS FOLLOWS:
 1 X 1 1/2 - 8 : 4-5/8-11 UNC-2B
 1 1/2 X 3 - 8 : 4-3/4-10 UNC-2B

INSTALL FOUNDATION BOLTS IN PIPE SLEEVES. ALLOW FROM .75" TO 1.50" FOR GROUTING. SEE INSTRUCTION BOOK FOR DETAILS.

FOR TAPPED OPENINGS REFER TO DRAWING NO. A04190A.

CERTIFIED FOR CONSTRUCTION PURPOSES ONLY WHEN SIGNED.

SIGNATURE *Joyce Suttaby* DATE 6-9-95

Goolds Serial # 786D951
 Cust: OHM REMEDIATION SERVICES CORP
 P.O. # 1005442
 Item # P-145 /PROJ. CAMP LEJEUNE
 Service: SUPERNATANT PUMP

| | | | | | |
|-------|--|---|--------------------|---------------|------------|
| ISSUE | DRAWING IS NOT TO SCALE DIMENSIONS IN INCHES WEIGHTS (LBS) ARE APPROXIMATE | DRAWN DDT 08-12-92 APPROVED PTH 05-10-93 | DRAWING A04485A | REVISION 0 | ISSUE 0 |
|-------|--|---|--------------------|---------------|------------|



GOULDS PUMPS, INC.

INDUSTRIAL PRODUCTS GROUP
ENGINEERED PRODUCTS DIV.

PUMP TAPPED OPENINGS
MODEL 3196 STX

TAPPED OPENINGS

| NO. | SIZE | QTY. | PURPOSE | FURNISHED | | NO. | SIZE | QTY. | PURPOSE | FURNISHED | |
|-----|------|------|-----------------------|-----------|----|-----|------|------|-------------------------|-----------|----|
| | | | | YES | NO | | | | | YES | NO |
| TB | 1/2 | 1 | CASING DRAIN | X | | TL1 | --- | 2 | FRAME COOLER ACCESS | X | |
| TC | 1/4 | 1 | BY-PASS CONNECTION | | X | TN | 1/4 | 4 | GREASE FITTING | X | |
| TD | 1/4 | 1 | DISCHARGE GAUGE CONN. | | X | TN2 | 1/4 | 2 | OIL MIST INJECTION PORT | X | |
| TE | 1/4 | 1 | SUCTION GAUGE CONN. | | X | TY | 1/2 | 1 | OIL FILL | X | |
| TF | 3/8 | 1 | BEARING FRAME DRAIN | X | | TZ | 1/4 | 1 | BOTTLE OILER CONNECTION | X | |
| TL | 1/2 | 2 | FRAME COOLING CONN. | | X | | | | | | |

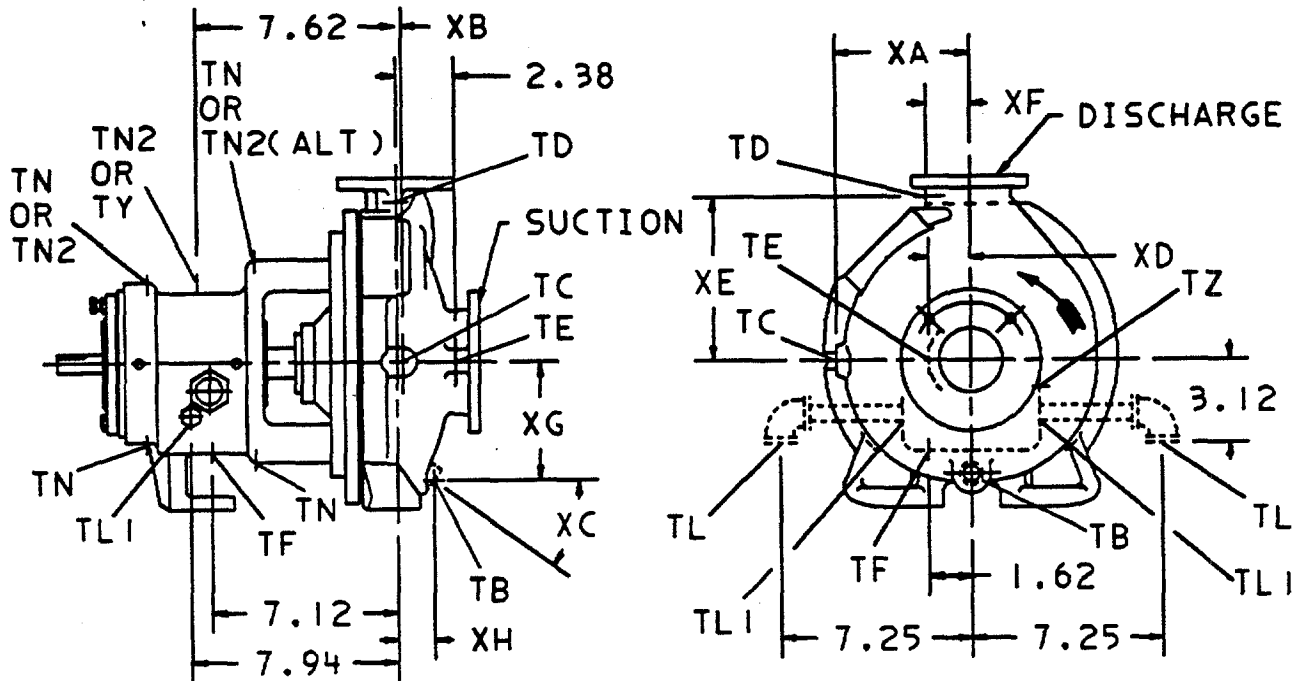

PUMP DIMENSIONS

| ANSI NO. | SIZE | XA | XB | XC | XD | XE | XF | XG | XH |
|----------|-----------|------|-----|-----|------|------|------|------|------|
| X AA | 1X1 1/2-6 | 4.00 | .38 | 30° | 1.44 | 4.94 | .94 | 3.69 | 1.50 |
| AB | 1 1/2X3-6 | 4.00 | .38 | 30° | 2.00 | 4.94 | 1.25 | 3.94 | 1.75 |
| A10 | 2X3-6 | 4.06 | .50 | 30° | 2.25 | 5.00 | 1.50 | 4.25 | 1.88 |
| AA | 1X1 1/2-8 | 4.94 | .25 | 0 | 1.50 | 5.81 | 2.00 | 4.31 | 1.50 |
| A50 | 1 1/2X3-8 | 5.00 | .25 | 0 | 2.00 | 5.81 | 2.50 | 4.38 | 1.81 |

CERTIFIED FOR CONSTRUCTION PURPOSES ONLY WHEN SIGNED.

SIGNATURE *Jonas Sutterly* DATE 6-9-95

Goulds Serial # 786D951
Cust: OHM REMEDIATION SERVICES CORP
P.O. # 1005442
Item # P-145 /PROJ. CAMP LEJEUNE
Service: SUPERNATANT PUMP

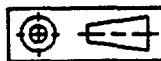

ISSUE

DRAWING IS NOT TO SCALE
DIMENSIONS IN INCHES

DRAWN

DJN
4-9-91

DRAWING

A04190A

REVISION

3

ISSUE

0

APPROVED

RAS
6-24-91



GOULDS PUMPS, INC.

INDUSTRIAL PRODUCTS GROUP
ENGINEERED PRODUCTS DIV.

PUMP TAPPED OPENINGS
GROUP-STX

STUFFING BOX/SEAL CHAMBERS/DYNAMIC SEAL

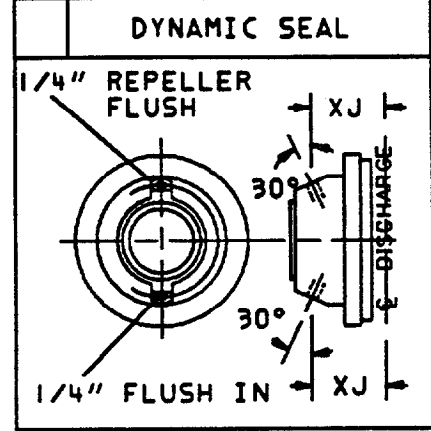
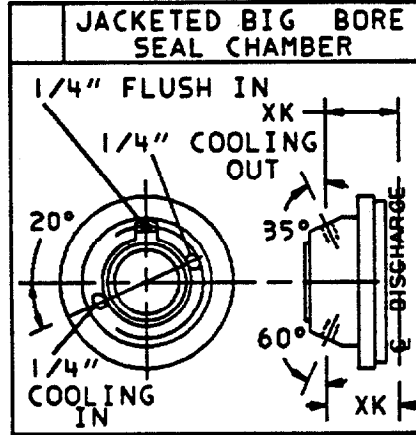
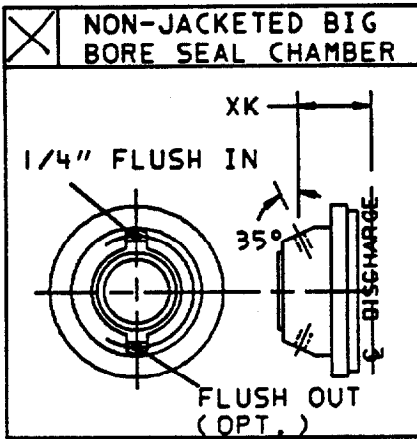
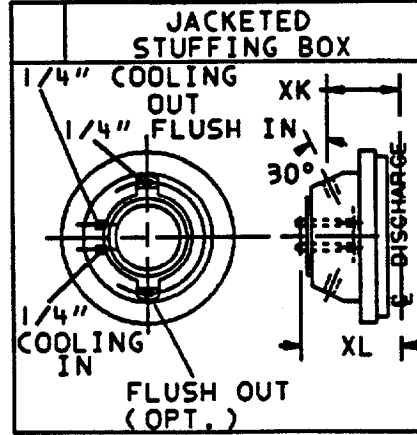
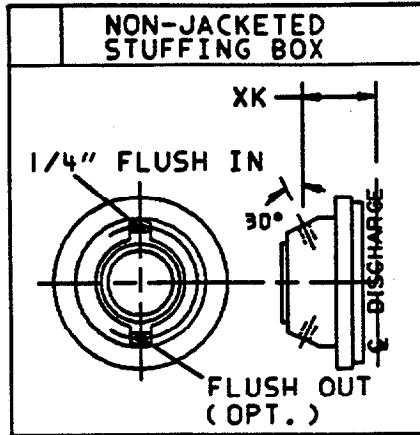

| PUMP DIMENSIONS | | | | |
|-----------------|-----------|------|------|--|
| PUMP MODEL | (MAXIMUM) | | | |
| | XK | XJ | XL | |
| 3196 | 2.00 | 2.50 | 4.00 | |
| 3796 | 4.00 | 5.00 | 6.00 | |
| 3996 | 2.00 | 2.50 | 4.00 | |
| LF3196 | 2.00 | 2.50 | 4.00 | |
| CV3196 | 4.00 | 5.00 | 6.00 | |

CERTIFIED FOR CONSTRUCTION PURPOSES ONLY WHEN SIGNED.

SIGNATURE *Joyce Sutterby* DATE 6-9-95

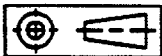

NOTE: TAPPED OPENINGS NOT AVAILABLE ON TAPER BORE™ PLUS SEAL CHAMBERS.

Goolds Serial # 786D951
Cust: OHM REMEDIATION SERVICES CORP
P.O. # 1005442
Item # P-145 /PROJ. CAMP LEJEUNE
Service: SUPERNATANT PUMP

ISSUE

DRAWING IS NOT TO SCALE
DIMENSIONS IN INCHES

DRAWN TJA
9-1-94
APPROVED PTM
9-6-94

DRAWING
A05460A

REVISION
0

ISSUE
0

**STUFFING BOX/SEAL CHAMBER GLAND OPTIONS
OPTION FURNISHED WHEN CHECKED**

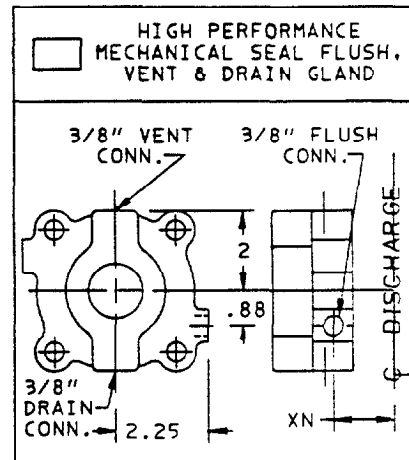
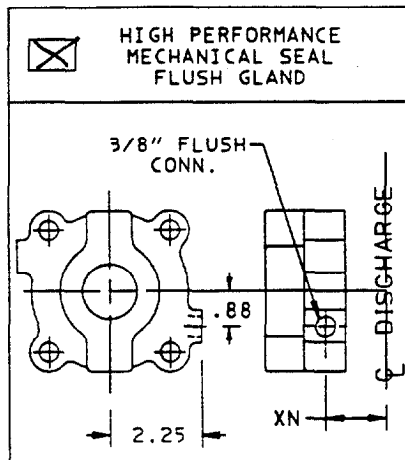
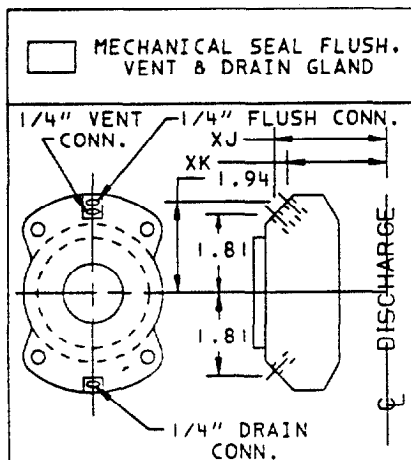
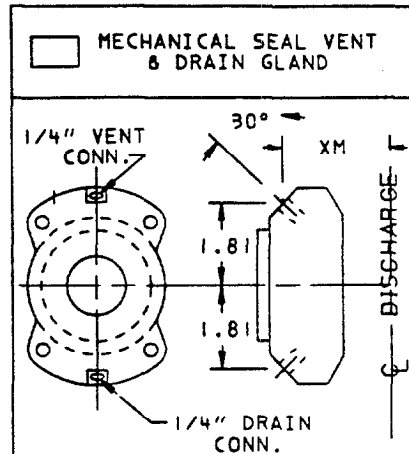
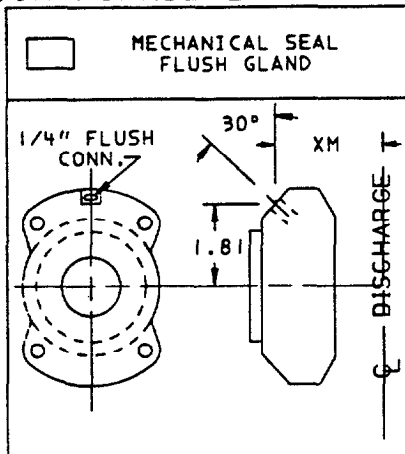
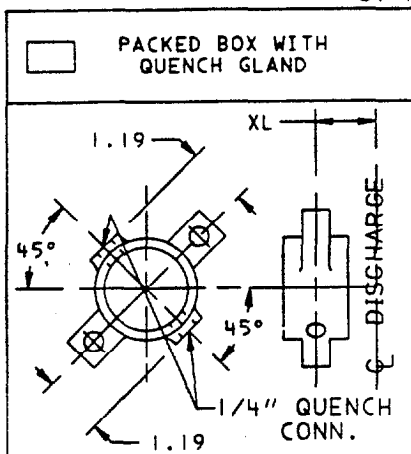

PUMP DIMENSIONS

| | PUMP MODEL | XJ | XK | XL | XM | XN |
|-------------------------------------|------------|------|------|------|------|------|
| <input checked="" type="checkbox"/> | 3196 | 3.81 | 3.00 | 3.25 | 3.50 | 3.44 |
| | 3796 | 5.81 | 5.00 | 5.25 | 5.50 | 5.44 |
| | 3996/ST | 3.81 | 3.00 | 3.25 | 3.50 | 3.44 |
| | LF3196 | 3.81 | 3.00 | 3.25 | 3.50 | 3.44 |
| | CV3196 | 6.00 | 5.50 | 5.75 | 6.00 | 5.94 |

CERTIFIED FOR CONSTRUCTION PURPOSES ONLY WHEN SIGNED.

SIGNATURE *Joyce Sutherland* DATE 6-9-95

Goolds Serial # 786D951
Cust: OHM REMEDIATION SERVICES CORP
P.O. # 1005442
Item # P-145 /PROJ. CAMP LEJEUNE
Service: SUPERNATANT PUMP

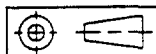

ISSUE

DRAWING IS NOT TO SCALE
DIMENSIONS IN INCHES

DRAWN TJA
9-01-94
APPROVED PTM
09-01-94

DRAWING
A05464A

REVISION
0

ISSUE
0

DATE 1-14-70

4-23-82 ISSUE #2
REV. DATE 3-17-78 ISSUE #1 B.E.F.

GOULDS PUMPS, INC.
SENECA FALLS NEW YORK 13148

CENTRIFUGAL PUMP CHARACTERISTICS

RPM 1750 - CDS 2077-2

MODEL 3196 STX

SIZE 1 x 1/2-6

IMP. DWG. 76777 / *76781*

PATTERN 56088 / *56206*

EYE AREA 3.14 in²

6 1/16" IMP. DIA.

**FOR DUCTILE IRON
CONSTRUCTION**

CERTIFIED PERFORMANCE DATA

GOULDS PUMPS, INC.
ENGINEERING PRODUCTS DIVISION
Seneca Falls, N. Y.

James Hall

Goolds Serial # 786D951
Cust: OHM REMEDIATION SERVICES CORP.
P.O. # 1005442
Item # P-145 / PROJ. CAMP LEJEUNE
Service: SUPERNATANT PUMP

TOTAL HEAD

metres

14
12
10
8
6
4
2
0

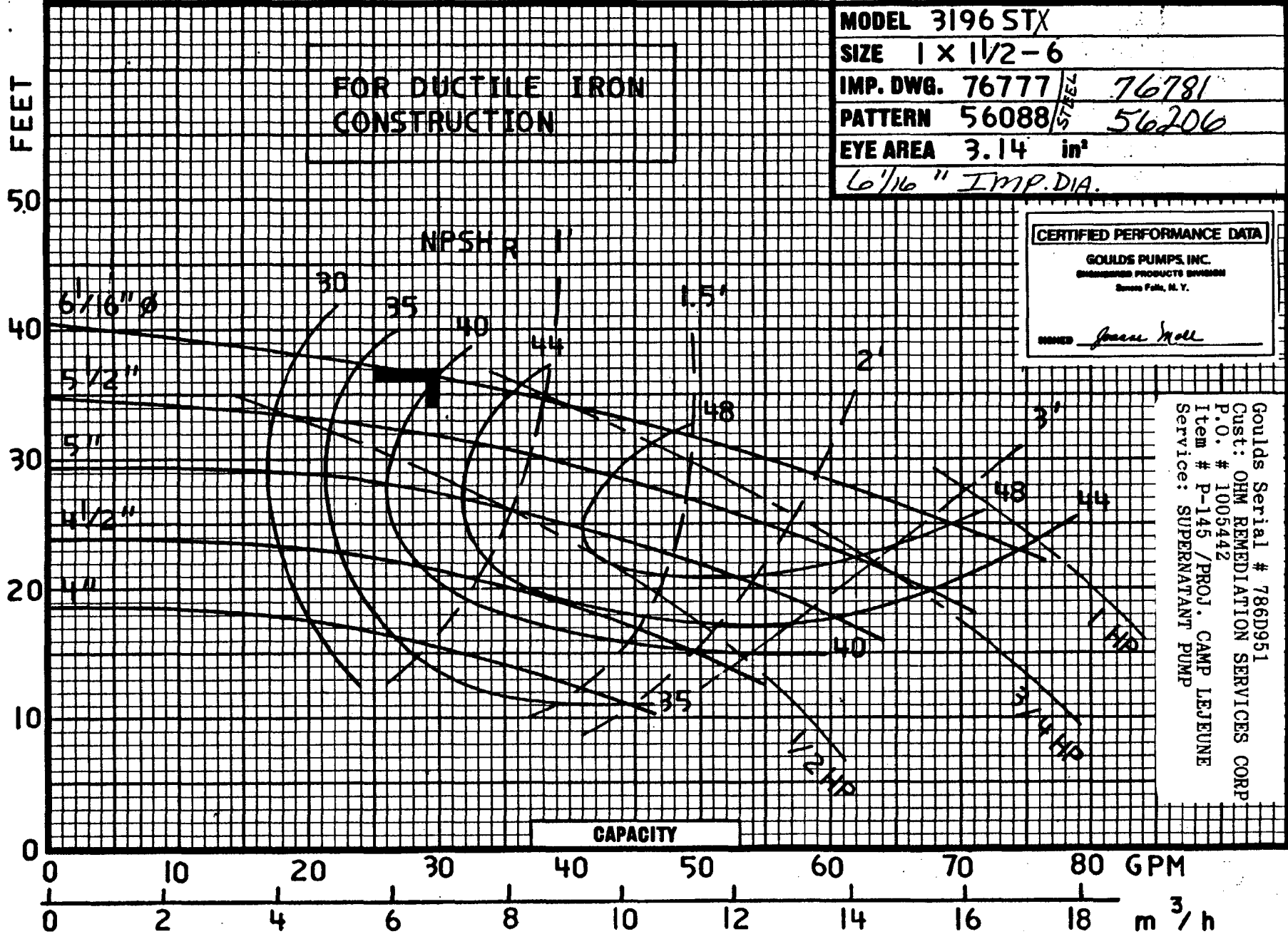

CAPACITY

GPM

m³/h

| BILL OF MATERIAL | | | |
|----------------------------|--------------|-------------------------|-----------|
| CONSTRUCTION: DUCTILE IRON | | | |
| ITEM NO | QTY PER PUMP | PART NAME | MATERIAL |
| 100 | 1 | CASING | DI |
| 101 | 1 | IMPELLER | 316SS |
| 105 | 2 | LANTERN RING HALF | TEFLON |
| 106 | 1 | STUFFING BOX PKG | NON-ASB |
| 107 | 1 | GLAND | 316SS |
| 112A | 1 | BALL BRG OTBD | STEEL |
| 113A | 1 | PLUG OIL FILL | STEEL |
| 122 | 1 | SHAFT | STEEL |
| 126 | 1 | SHAFT SLEEVE | 316SS |
| 134 | 1 | BRG HOUSING | CI |
| 136 | 1 | BRG LOCK NUT | STEEL |
| 168A | 1 | BALL BRG INBD | STEEL |
| 184 | 1 | S.B. COVER/SEAL CHAM. | DI |
| 228 | 1 | FRAME | DI |
| 319 | 1 | SIGHT GLASS | STL/GLASS |
| 332A | 1 | LBVR SEAL OTBD W/O-RING | TFL/GPH |
| 333A | 1 | LBVR SEAL INBD W/O-RING | TFL/GPH |
| 351 | 1 | GASKET-CASE | EPDM-RBR |
| 353 | 2 | STUD-GLAND | 316SS |
| 355 | 2 | NUT GLAND STUD | 304SS |
| 361A | 1 | RTNG RING-BRG HSG | STEEL |
| 370 | 4 | H CAP SCR-FR-CASE | STEEL |
| 370B | 4 | H CAP SCR-ADPTR-FR | STEEL |
| 370C | 3 | H TAP BOLT-BRG HSG | STEEL |
| 370D | 3 | H TAP BOLT-IMPLR-ADJ | STEEL |
| 370H | 2 | STUD-COVER-ADPTR | 304SS |
| 382 | 1 | BRG LOCKWASHER | STEEL |
| 400 | 1 | KEY-SQUARE | STEEL |
| 408A | 1 | MAG. PLUG-OIL DRAIN | STEEL |
| 408J | 1 | PLUG, SIGHT OILER | STEEL |
| 408H | 4 | PLUG, OIL MIST CONN | STEEL |
| 412A | 1 | O-RING IMPELLER | TEFLON |
| 418 | 3 | H TAP BOLT-JACKING | 304SS |
| 423 | 3 | JAM NUT FOR 370D | STEEL |
| 496 | 1 | O-RING-BRG HSG | BUNA-RBR |
| 497F | 1 | O-RING, OTBD SEAL ROT. | VITON |
| 497G | 1 | O-RING, OTBD SEAL STA. | VITON |
| 497H | 1 | O-RING, INBD SEAL ROT. | VITON |
| 497J | 1 | O-RING, INBD SEAL STA. | VITON |
| 503 | 1 | ADAPTER RING | DI |

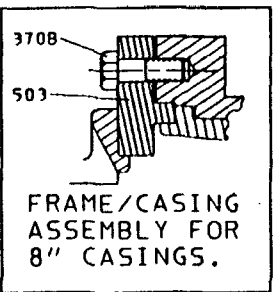
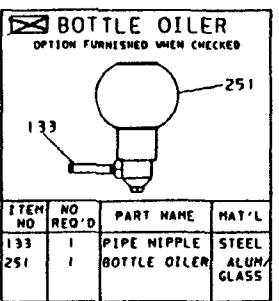

- * RECOMMENDED SPARE PARTS.
- Ⓐ ITEM 370 IS QTY 8 FOR 8" CASINGS.
 - Ⓑ GLAND BOLTING FOR PACKING GLAND (ITEM 353 & 355) IS QTY 2, FOR MECHANICAL SEAL QTY 4.
 - Ⓒ ITEMS NOT ILLUSTRATED.

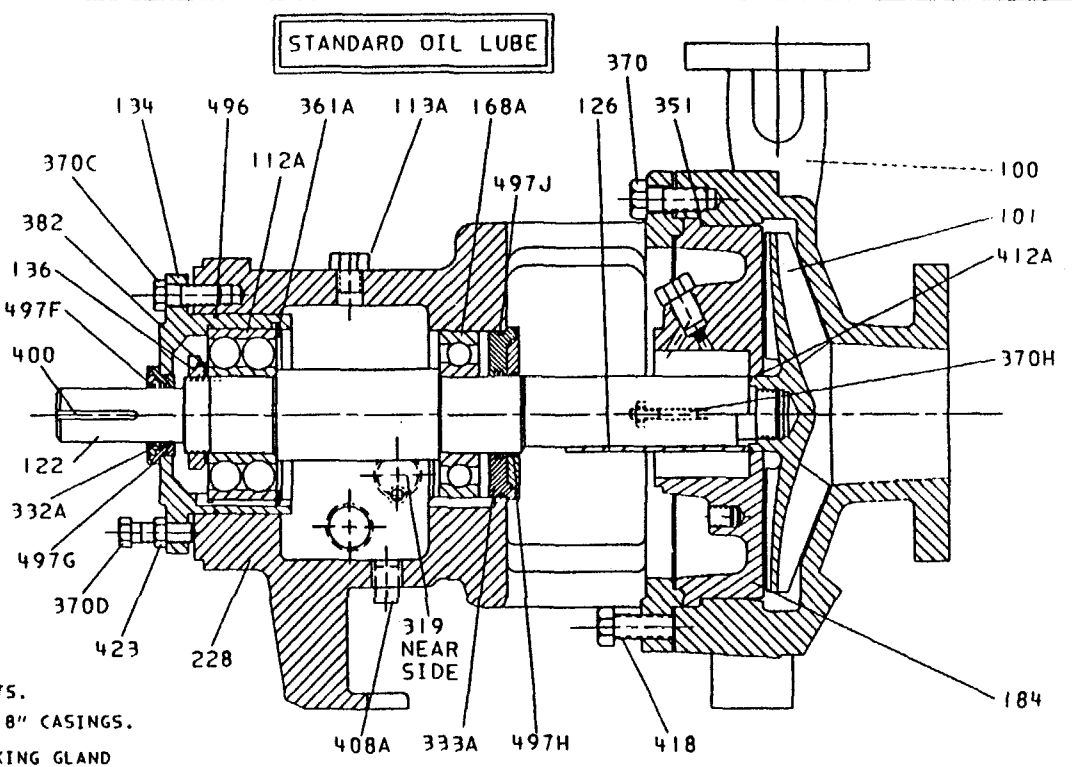

STUFFING BOX COVER / SEAL CHAMBER OPTIONS - CHECK OPTION REQUIRED

STUFFING BOX
 NONJACKETED (SHOWN)
 JACKETED

REFER TO SEAL DRAWING NO. 265-251541 ATTACHED TO FOLLOW

TAPER BORE™ PLUS

BIG BORE™ STD. FLUSH
 NONJACKETED (SHOWN)
 JACKETED

BIG BORE™ WITH INTERNAL BY-PASS

Goolds Serial # 786D951
 Cust: OHM REMEDIATION SERVICES CORP
 P.O. # 1005442
 Item # P-145 /PROJ. CAMP LEJEUNE
 Service: SUPERNATANT PUMP

PUMP CROSS SECTION DRAWING
 MODEL 3196STX

GOULDS PUMPS, INC.
 INDUSTRIAL PRODUCTS GROUP
 ENGINEERED PRODUCTS DIV.

| | | | |
|--------------------------|----------------------------|-----------------------------|---------------------------|
| DRAWN THO 05-28-91 | CHECKED THO 05-28-91 | APPROVED RAS 06-28-91 | THIRD ANGLE PROJECTION |
| DRAWING IS NOT TO SCALE | | | REV. 2 |
| DRAWING B02991A2 | | | |



GOULDS PUMPS, INC.
ENGINEERED PRODUCTS DIVISION

LUBRICANT DATA SHEET

CUSTOMER INFORMATION

Goulds Serial # 786D951
Cust: OHM REMEDIATION SERVICES CORP
P.O. # 1005442
Item # P-145 /PROJ. CAMP LEJEUNE
Service: SUPERNATANT PUMP

EQUIPMENT IDENTIFICATION

MODEL 3196STX SIZE 1X1 1/2-6
LUBRICATION OIL
CONST. DI / 316SS

| PART LUBRICATED | LUBRICANT | | FILL CAPACITY | CONSUMPT. AMT. / TIME | RECOMMENDED LUBRICANT MFR. & NO. & REMARKS |
|---------------------------|------------------------|----------|-----------------------------------|--|--|
| | TYPE | VISC. | | | |
| BEARING HOUSING/ FRAME | TURBINE TYPE OIL | ISOVG-68 | APPROX. ONE (1) PT (400 ML) | REFILL AP- PROXIMATELY EVERY (3) THREE MONTHS OR 2000 HRS. | OIL MUST BE VISIBLE AT CENTER OF SIGHT GLASS. |

REV. DATE

| | | | | | | |
|--|--|--|----------------------------------|--------------------------------------|----------------------------------|------------------|
| | | | WRITTEN BY FAK 5/1/92 DATE | APPROVED BY J.MOLL DATE 5/1/92 | DRAWING NO. <u>196 STXLDS</u> | REV. <u>0</u> |
|--|--|--|----------------------------------|--------------------------------------|----------------------------------|------------------|

SHEET 1 OF 1



TYPE SC SPACER COUPLINGS

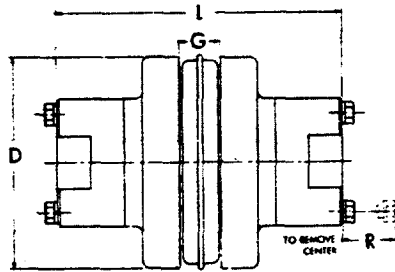
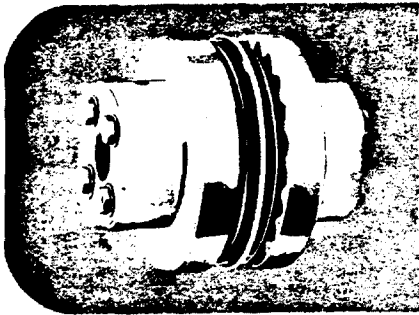

The table below shows assembled dimensions of Sure-Flex Type SC Spacer Couplings. For dimensions of separate components, refer to page 19.

| Coupling Size | Required Distance Between Shafts | Use Flange No. | Use Hub No. | Max. Bore Std. KS | Dimensions | | | | Wt. ⁽²⁾ (lbs.) |
|---------------|----------------------------------|----------------|-------------|----------------------|------------|------------------|--------|--------|---------------------------|
| | | | | | D | L ⁽¹⁾ | G | R | |
| 4JSC | 3 1/2 | 4JSC35 | ... | 1 1/2 ⁽¹⁾ | 2.460 | 5 5/8 | 3/4 | ... | 2.7 |
| 5SC | 3 1/2 | 5SC35 | 5H | 1 1/8 | 3.250 | 5 3/8 | 3/4 | 5/16 | 4.5 |
| 6SC | 3 1/2 | 6SC35 | 6H | 1 3/8 | 4.000 | 5 1/8 | 7/8 | 3/4 | 7.3 |
| | 4 3/8 | 6SC44 | 6H | 1 1/2 | 4.000 | 6 1/8 | 7/8 | 3/4 | 8.1 |
| 7SC | 5 | 6SC50 | 6H | 1 3/8 | 4.000 | 7 3/8 | 7/8 | 3/4 | 8.7 |
| | 3 1/2 | 7SC35 | 7H | 1 1/8 | 4.625 | 6 3/8 | 1 | 5/8 | 9.9 |
| | 4 3/8 | 7SC44 | 7H | 1 1/8 | 4.625 | 7 1/8 | 1 | 5/8 | 10.8 |
| 8SC | 5 | 7SC50 | 7H | 1 1/8 | 4.625 | 7 7/8 | 1 | 5/8 | 11.4 |
| | 3 1/2 | 8SC35 | 8H | 1 1/8 | 5.450 | 6 7/8 | 1 1/8 | 3/16 | 15.2 |
| | 3 1/2 | 8SC35-10 | 10H* | 2 3/8 | 5.450 | 8 1/8 | 1 1/8 | 3/16 | 23.2 |
| 9SC | 4 3/8 | 8SC44 | 8H | 1 1/8 | 5.450 | 7 3/4 | 1 1/8 | 3/16 | 16.4 |
| | 5 | 8SC50 | 8H | 1 1/8 | 5.450 | 8 3/8 | 1 1/8 | 1 3/16 | 17.4 |
| | 5 | 8SC50-10 | 10H* | 2 3/8 | 5.450 | 9 3/8 | 1 1/8 | 1 3/16 | 27.2 |
| 10SC | 3 1/2 | 9SC35 | 9H* | 2 1/8 | 6.350 | 7 1/2 | 1 1/16 | 1 1/16 | 18.6 |
| | 4 3/8 | 9SC44 | 9H* | 2 1/8 | 6.350 | 8 1/2 | 1 1/16 | 1 1/16 | 22.2 |
| | 5 | 9SC50 | 9H* | 2 1/8 | 6.350 | 8 3/8 | 1 1/16 | 1 1/16 | 23.2 |
| | 5 | 9SC50-11 | 11H* | 2 1/8 | 6.350 | 10 3/8 | 1 1/16 | 1 3/16 | 40.4 |
| | 7 | 9SC70-11 | 11H* | 2 1/8 | 6.350 | 12 3/8 | 1 1/16 | 1 3/16 | 48.2 |
| 11SC | 7 1/2 | 9SC78-11 | 11H* | 2 1/8 | 6.350 | 13 3/8 | 1 1/16 | 1 3/16 | 51.0 |
| | 4 3/8 | 10SC48 | 10H* | 2 1/8 | 7.500 | 9 3/8 | 1 1/8 | 1 1/16 | 37.6 |
| | 5 | 10SC50 | 10H* | 2 1/8 | 7.500 | 9 3/8 | 1 1/8 | 1 3/16 | 38.4 |
| | 7 | 10SC70-13 | 13H* | 3 1/8 | 7.500 | 13 3/8 | 1 1/8 | 1 1/8 | 72.0 |
| | 7 1/2 | 10SC78-13 | 13H* | 3 1/8 | 7.500 | 14 3/8 | 1 1/8 | 1 1/8 | 76.0 |
| 12SC | 10 | 10SC100-13 | 13H* | 3 1/8 | 7.500 | 16 3/8 | 1 1/8 | 1 1/8 | 88.0 |
| | 4 3/8 | 11SC48 | 11H* | 2 3/8 | 8.625 | 10 3/16 | 1 1/8 | 1 3/16 | 54.5 |
| | 5 | 11SC50 | 11H* | 2 3/8 | 8.625 | 10 3/8 | 1 1/8 | 1 3/16 | 54.7 |
| | 7 | 11SC70-14 | 14H | 3 3/8 | 8.625 | 14 3/8 | 1 1/8 | 2 | 86.1 |
| | 7 1/2 | 11SC78-14 | 14H | 3 3/8 | 8.625 | 15 3/8 | 1 1/8 | 2 | 90.3 |
| 13SC | 10 | 11SC100-14 | 14H | 3 3/8 | 8.625 | 17 3/8 | 1 1/8 | 2 | 102.7 |
| | 7 | 12SC70 | 12H* | 2 3/8 | | | | | |
| 14SC | 7 | 12SC70-14 | 14H | 3 3/8 | | | | | |
| | 7 1/2 | 12SC78 | 12H* | 2 3/8 | | | | | |
| | 7 1/2 | 12SC78-14 | 14H | 3 3/8 | | | | | |
| 13SC | 7 1/2 | 12SC100-14 | 14H | 3 3/8 | | | | | |
| 14SC | 7 1/2 | 13SC78 | 13H* | 3 3/8 | | | | | |
| | | 14SC78 | 14H | 3 3/8 | | | | | |

Goulds Serial # 786D951
 Cust: OHM REMEDIATION SERVICES CORP
 P.O. # 1005442
 Item # P-145 / PROJ. CAMP LEJEUNE
 Service: SUPERNATANT PUMP

*Short (HS) hub also available. ■ Approximate weight for completely assembled spacer coupling.
 (1) 4JSC35 x 1 1/2 has shallow keyseat. (2) "L" dimension and weight will change if one or two short (HS) hubs used.
 Note: Refer to page 19 to order — specify components separately.

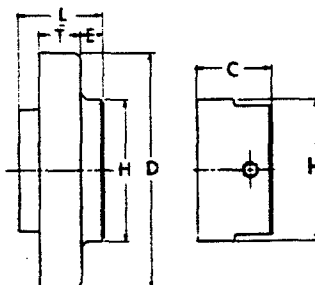
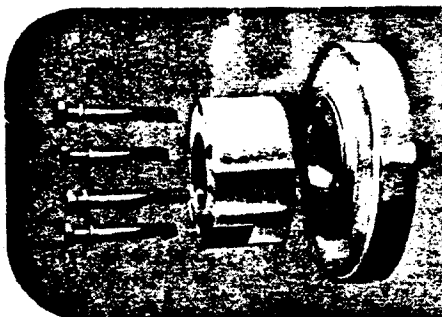

TYPE SC FLANGES AND HUBS

Tables on page 19 provide dimensional information for flanges and hubs used for Spacer Couplings. For assembled dimensions, see table above. Any of the sleeves shown on page 10 may be used.

 **GOULDS PUMPS, INC.**
INDUSTRIAL PRODUCTS GROUP

Engineering Document Package

Goulds Serial # 786D830
Cust: OHM REMEDIATION SERVICES CORP.
P.O. # 1005430
Item # P-241 PROJ. CAMP LEJEUNE
Service: BACKWASH PUMP

| SUBMITTAL REVIEW | |
|---|---|
| REVIEW IS FOR GENERAL COMPLIANCE WITH CONTRACT DOCUMENTS NO RESPONSIBILITY IS ASSUMED FOR CORRECTNESS OF DIMENSIONS OR DETAILS. THE CONTRACTOR/SUPPLIER SHALL ASSUME FULL RESPONSIBILITY FOR DEVIATIONS FROM CONTRACT REQUIREMENTS NOT SPECIFICALLY INDICATED ON THIS SUBMITTAL. | |
| <input checked="" type="checkbox"/> NO EXCEPTIONS | <input type="checkbox"/> MAKE CORRECTIONS NOTED |
| <input type="checkbox"/> AMEND AND RESUBMIT | <input type="checkbox"/> REJECTED - SEE REMARKS |
| Date <u>6-21-95</u> By <u>B. Paulsen</u> | |
| OHM REMEDIATION SERVICES CORP. NORCROSS, GEORGIA | |



GOULDS PUMPS, INC.
INDUSTRIAL PRODUCTS GROUP



GOULDS PUMPS, INC.

INDUSTRIAL PRODUCTS GROUP
ENGINEERED PRODUCTS DIV.

PUMP OUTLINE DRAWING
MODEL 3196 MTX, LTX

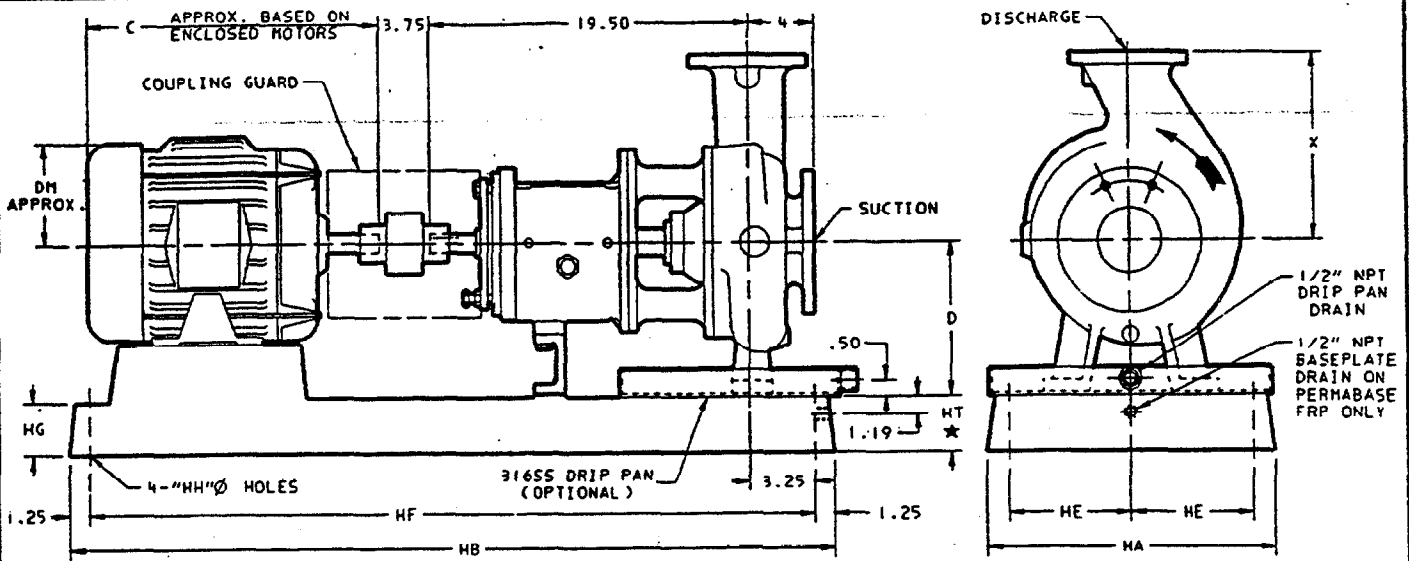

| MOTOR DIMENSIONS (TEFC) | | | | | |
|-------------------------|------|----|----|-----------------|----------|
| MOTORS | | C | DM | WT. INCL. CPLG. | BASE NO. |
| NEHA | IEC | | | | |
| 56 | 80 | 11 | 4 | 35 | 1 |
| 143T | 90S | 13 | 4 | 40 | 1 |
| 145T | 90L | 14 | 4 | 45 | 1 |
| 182T | 100L | 15 | 5 | 65 | 1 |
| 184T | 112M | 16 | 5 | 75 | 1 |
| 213T | 132S | 18 | 6 | 150 | 1 |
| 215T | 132M | 20 | 6 | 160 | 1 |
| 254T | 160M | 23 | 7 | 255 | 2 |
| 256T | 160L | 24 | 7 | 280 | 2 |
| 284T | 180M | 26 | 8 | 375 | 2 |
| 284TS | ---- | 25 | 8 | 345 | 2 |
| 286T | 180L | 27 | 8 | 430 | 2 |
| 286TS | ---- | 26 | 8 | 380 | 2 |
| 324T | 200M | 29 | 9 | 575 | 3 |
| 324TS | ---- | 27 | 9 | 485 | 3 |
| 326T | 200L | 30 | 9 | 640 | 3 |
| 326TS | ---- | 29 | 9 | 570 | 3 |
| 364T | 225S | 33 | 10 | 810 | 3A |
| 364TS | ---- | 31 | 10 | 755 | 3A |
| 365T | 225M | 34 | 10 | 950 | 3A |
| 365TS | ---- | 32 | 10 | 865 | 3A |
| 404TS | ---- | 34 | 11 | 1080 | 4 |
| 405TS | ---- | 36 | 11 | 1110 | 4 |
| 444TS | ---- | 39 | 13 | 1510 | 4A |

| BASEPLATE DIMENSIONS | | | | | | | | | | | | | |
|----------------------|----|----|-------------|------|-----------|------|-----------|------|------|-------|------|-----------|-----|
| NO. | HA | HB | HT (D=8.25) | | HT (D=10) | | HG | | HE | HF | HM | WEIGHT | |
| | | | CAST IRON | FRP | CAST IRON | FRP | CAST IRON | FRP | | | | CAST IRON | FRP |
| 1 | 12 | 45 | 3.81 | 3.94 | 3.81 | 3.94 | 3.75 | 3.62 | 4.50 | 42.50 | .75 | 105 | 44 |
| 2 | 15 | 52 | 4.19 | 4.31 | 4.19 | 4.31 | 4.12 | 4.00 | 6.00 | 49.50 | .75 | 155 | 56 |
| 3 | 18 | 58 | 4.81 | 5.06 | 4.81 | 5.06 | 4.75 | 4.75 | 7.50 | 55.50 | 1.00 | 205 | 77 |
| 3A | 18 | 58 | 5.81 | 6.06 | 4.81 | 5.06 | 4.75 | 4.75 | 7.50 | 55.50 | 1.00 | 205 | 77 |
| 4 | 18 | 60 | 6.81 | NA | 5.06 | NA | 4.75 | NA | 7.50 | 57.50 | 1.00 | 240 | NA |
| 4A | 18 | 60 | 7.81 | NA | 6.06 | NA | 4.75 | NA | 7.50 | 57.50 | 1.00 | 240 | NA |

| PUMP DIMENSIONS | | | | | | |
|-----------------|-------------|------------|-------------|-------|-------|------|
| ANSI NO. | DISCH. SIZE | SUCT. SIZE | CAS'G CLASS | D | X | WGT. |
| A70 | 3 | 4 | 7 | 8.25 | 11.00 | 240 |
| A60 | 2 | 3 | 8 | 8.25 | 9.50 | 220 |
| A70 | 3 | 4 | 8G | 8.25 | 11.00 | 240 |
| A70 | 3 | 4 | 8 | 8.25 | 11.00 | 240 |
| A05 | 1 | 2 | 10 | 8.25 | 8.50 | 220 |
| A50 | 1 1/2 | 3 | 10 | 8.25 | 8.50 | 240 |
| A60 | 2 | 3 | 10 | 8.25 | 9.50 | 250 |
| A70 | 3 | 4 | 10 | 8.25 | 11.00 | 285 |
| A40 | 3 | 4 | 10H | 10.00 | 12.50 | 295 |
| A80 | 4 | 6 | 10 | 10.00 | 13.50 | 325 |
| A70 | 4 | 6 | 10H | 10.00 | 13.50 | 336 |
| A20 | 1 1/2 | 3 | 13 | 10.00 | 10.50 | 265 |
| A30 | 2 | 3 | 13 | 10.00 | 11.50 | 295 |
| A40 | 3 | 4 | 13 | 10.00 | 12.50 | 350 |
| A80 | 4 | 6 | 13 | 10.00 | 13.50 | 425 |

| PUMP MODEL |
|--|
| <input checked="" type="checkbox"/> 3196 MTX |
| <input type="checkbox"/> 3196 LTX |

| AVAILABLE OPTIONS |
|--|
| <input checked="" type="checkbox"/> BASEPLATE: CAST IRON |
| <input type="checkbox"/> PERMABASE™ FRP |
| <input type="checkbox"/> Y-BASE™ |
| 316SS DRIP PAN: |
| <input type="checkbox"/> FURNISHED |
| <input checked="" type="checkbox"/> NOT FURNISHED |
| FLANGES: |
| <input checked="" type="checkbox"/> 150# ANSI FLAT FACE |
| <input type="checkbox"/> 150# ANSI RAISED FACE |
| <input type="checkbox"/> 300# ANSI FLAT FACE |
| <input type="checkbox"/> 300# ANSI RAISED FACE |
| CPLG. GUARD FURNISHED BY: |
| <input checked="" type="checkbox"/> GOULDS |
| <input type="checkbox"/> OTHERS |

INSTALL FOUNDATION IN PIPE SLEEVES. ALLOW .75 TO 1.50 FOR GROUTING. SEE INSTRUCTION BOOK FOR DETAILS.

◆ SUCTION FLANGE HAS (8) 3/4-10 UNC TAPPED HOLES FOR 300# CASING ONLY.

■ SUCTION FLANGE HAS (8) 3/4-10 UNC TAPPED HOLES FOR 150# CASING. (12) 3/4-10 UNC TAPPED HOLES FOR 300# CASING.

◆ FOR 3196 LTX. ADD 20 LBS. TO PUMP WEIGHT GIVEN.

★ TOLERANCE IS +0 -.50 FOR CAST IRON BASEPLATE.

FOR TAPPED OPENINGS REFER TO DRAWING A04196A

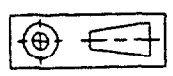

CERTIFIED FOR CONSTRUCTION PURPOSES ONLY WHEN SIGNED.

SIGNATURE *Joyce Sutterby* DATE 6-8-95

Goulds Serial # 786D830
Cust: OHM REMEDIATION SERVICES CORP.
P.O. # 1005430
Item # P-241 PROJ. CAMP LEJBUNE
Service: BACKWASH PUMP

| | | | | | |
|-------|--|--------------------------|--------------------|---------------|------------|
| ISSUE | DRAWING IS NOT TO SCALE DIMENSIONS IN INCHES WEIGHTS (LBS) ARE APPROXIMATE | DRAWN DDT 08-14-92 | DRAWING A04487A | REVISION 0 | ISSUE 0 |
| | | APPROVED PTH 05-14-93 | | | |



GOULDS PUMPS, INC.

INDUSTRIAL PRODUCTS GROUP
ENGINEERED PRODUCTS DIV.

PUMP TAPPED OPENINGS
MODEL 3196 MTX, LTX

TAPPED OPENINGS

| NO. | SIZE | QTY. | PURPOSE | FURNISHED | | NO. | SIZE | QTY. | PURPOSE | FURNISHED | |
|-----|------|------|-----------------------|-----------|----|-----|------|------|-------------------------|-----------|----|
| | | | | YES | NO | | | | | YES | NO |
| TB | 1/2 | 1 | CASING DRAIN | X | | TL1 | --- | 2 | FRAME COOLER ACCESS | X | |
| TC | 1/2 | 1 | BY-PASS CONNECTION | | X | TN | 1/4 | 4 | GREASE FITTING | X | |
| TD | 3/8 | 1 | DISCHARGE GAUGE CONN. | | | TN2 | 1/4 | 2 | OIL MIST INJECTION PORT | X | |
| TE | 3/8 | 1 | SUCTION GAUGE CONN. | X | | TY | 1/2 | 1 | OIL FILL | X | |
| TF | 3/8 | 1 | BEARING FRAME DRAIN | X | | TZ | 1/4 | 1 | BOTTLE OILER CONNECTION | X | |
| TL | 1/2 | 2 | FRAME COOLING CONN. | | X | | | | | | |

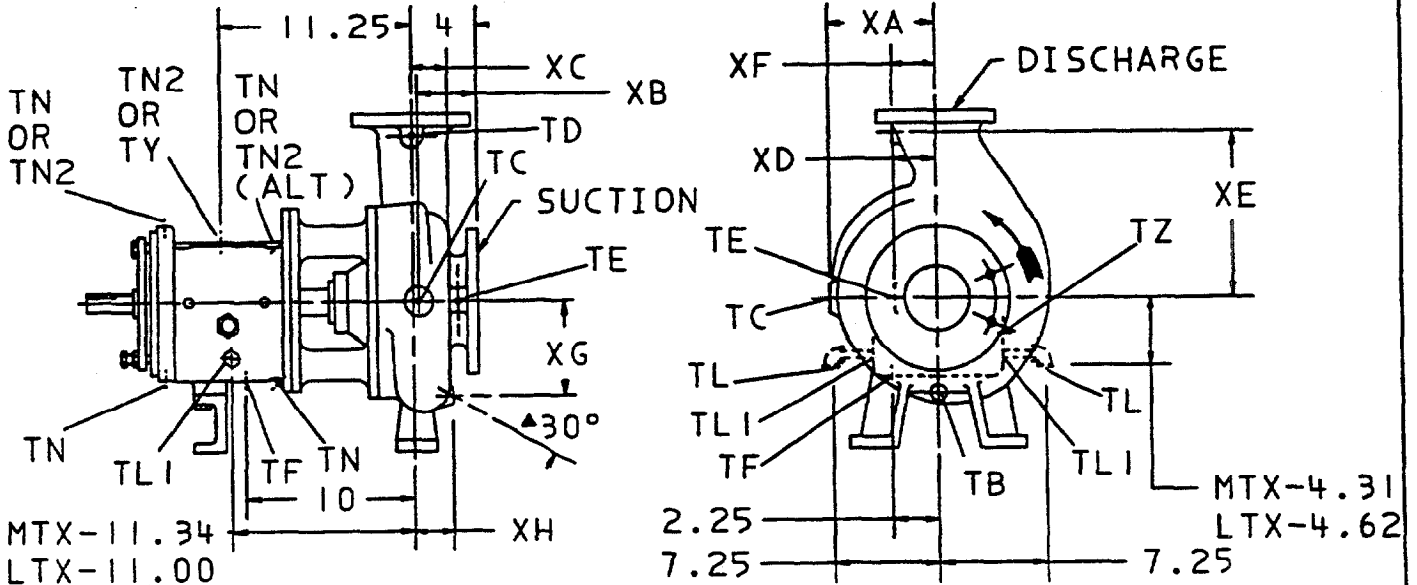

PUMP DIMENSIONS

| ANSI NO. | SIZE | XA | XB | XC | XD | XE | XF | XG | XH | |
|----------|------------|------------|------|------|------|------|-------|------|------|------|
| A70 | 3X4-7 | 5.88 | 3.81 | NA | NA | 9.12 | 2.12 | 5.75 | 1.75 | |
| A60 | 2X3-8 | 5.88 | 3.81 | 2.38 | 2.00 | 8.00 | 1.50 | 4.62 | 1.44 | |
| A70 | 3X4-8G | 5.88 | 3.69 | 2.38 | 2.62 | 9.31 | 2.06 | 5.12 | 1.81 | |
| A70 | 3X4-8 | 6.12 | 3.38 | 2.62 | 2.75 | 9.12 | 2.12 | 5.88 | 2.38 | |
| A05 | 1X2-10 | 6.00 | 4.12 | 2.38 | 1.75 | 7.25 | 1.00 | 5.38 | 1.00 | |
| A50 | 1 1/2X3-10 | 6.75 | 4.25 | 2.38 | 2.38 | 7.19 | 1.00 | 5.81 | 1.03 | |
| A60 | 2X3-10 | 6.75 | 4.12 | 2.38 | 2.38 | 7.88 | 1.31 | 5.56 | 1.12 | |
| A70 | 3X4-10 | 6.75 | 4.00 | 2.38 | 2.62 | 9.12 | 1.75 | 5.88 | 1.50 | |
| X | A40 | 3X4-10H | 7.62 | 4.00 | NA | NA | 10.62 | 2.12 | 6.88 | 1.88 |
| | A80 | 4X6-10 | 6.88 | 3.56 | NA | NA | 11.38 | 2.44 | 7.25 | 2.50 |
| | A70 | 4X6-10H | 7.94 | 4.00 | NA | NA | 11.38 | 2.50 | 7.62 | 3.34 |
| | A20 | 1 1/2X3-13 | 8.25 | 4.25 | 2.25 | 2.06 | 8.94 | 1.25 | 7.19 | 1.38 |
| | A30 | 2X3-13 | 8.25 | 4.12 | 2.38 | 2.19 | 9.88 | 1.50 | 7.44 | 1.94 |
| | A40 | 3X4-13 | 8.50 | 4.00 | 2.62 | 2.62 | 10.62 | 2.12 | 7.88 | 1.69 |
| | A80 | 4X6-13 | 8.69 | 3.88 | NA | NA | 11.38 | 2.50 | 8.38 | 2.62 |

CERTIFIED FOR CONSTRUCTION PURPOSES ONLY WHEN SIGNED.

SIGNATURE *Joyce Sutterly* DATE 6-8-95

PUMP MODEL

3196 MTX

3196 LTX

◆XD=2.38 FOR 300# CASING.

●XB=3.25 FOR 300# CASING.

▲30° ON SIZE 2X3-6, 3X4-7, 8 4X6-10 ONLY. ALL OTHERS ARE HORIZONTAL.

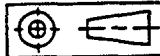

Goulds Serial # 786D830
 Cust: OHM REMEDIATION SERVICES CORP.
 P.O. # 1005430
 Item # P-241 PROJ. CAMP LBJBUNE
 Service: BACKWASH PUMP

ISSUE

DRAWING IS NOT TO SCALE
DIMENSIONS IN INCHES

DRAWN DOT 3-25-91
 APPROVED RAS 6-24-91

DRAWING A04196A

REVISION 3

ISSUE 0



GOULDS PUMPS, INC.

INDUSTRIAL PRODUCTS GROUP
ENGINEERED PRODUCTS DIV.

PUMP TAPPED OPENINGS
GROUP-MTX/LTX

STUFFING BOX/SEAL CHAMBERS/DYNAMIC SEAL

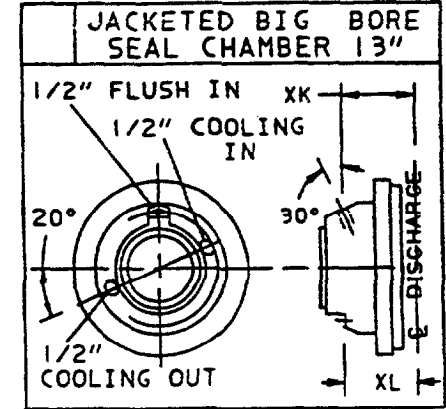
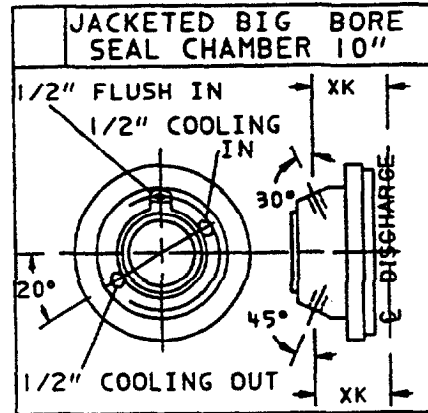
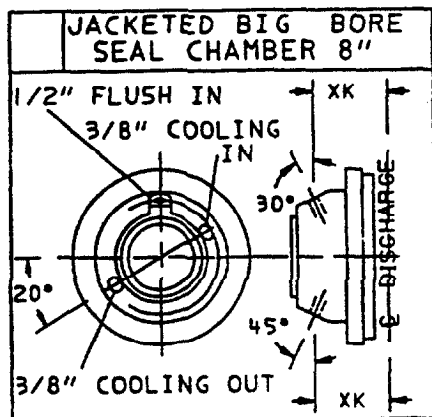
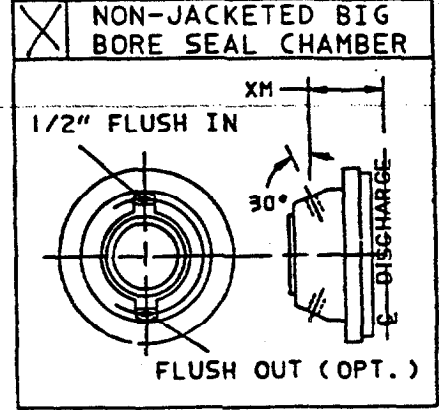
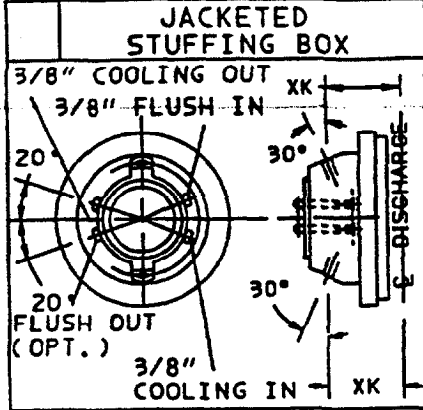
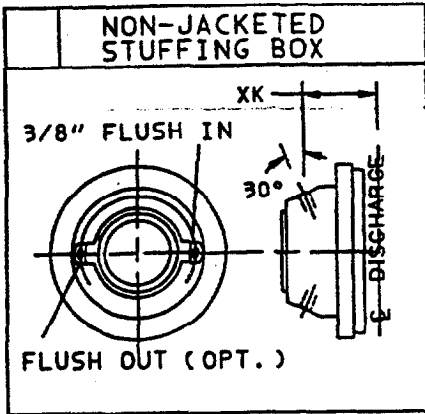

| PUMP DIMENSIONS | | | | |
|--|-------|-----------|-------|-------|
| PUMP MODEL | XK | (MAXIMUM) | | XM |
| | | XJ | XL | |
| <input checked="" type="checkbox"/> 3196 | 3.38 | 2.50 | 3.06 | 3.50 |
| <input type="checkbox"/> 3796: | | | | |
| 2X2-10 | 5.50 | 4.81 | 5.19 | 5.62 |
| 3X3-10 | 6.38 | 5.69 | 6.06 | 6.50 |
| 4X4-10 | 7.12 | 6.44 | 6.81 | 7.25 |
| 3X3-13 | 6.38 | 5.69 | 6.06 | 6.50 |
| 4X4-13 | 7.12 | 6.44 | 6.81 | 7.25 |
| 6X6-13 | 11.50 | 10.81 | 11.19 | 11.62 |
| 3996 | 3.88 | 3.00 | 3.56 | 4.00 |
| LF 3196 | 3.38 | 2.50 | 3.06 | 3.50 |
| <input type="checkbox"/> CV 3196: | | | | |
| 2X2-10 | 5.50 | 4.81 | 5.38 | 5.62 |
| 3X3-10 | 6.19 | 5.69 | 6.06 | 6.31 |
| 2X3-13 | 6.00 | 5.69 | 5.88 | 6.19 |
| 3X4-13 | 6.50 | 6.44 | 6.06 | 6.69 |

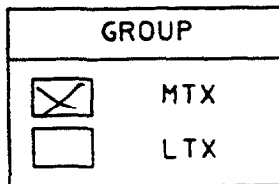
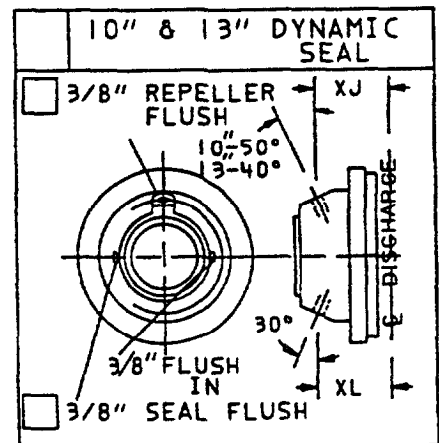

NOTE: TAPPED OPENINGS NOT AVAILABLE ON TAPER BORE™ PLUS SEAL CHAMBERS

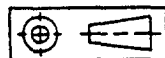

8" DYNAMIC SEAL IS NOT AVAILABLE

CERTIFIED FOR CONSTRUCTION PURPOSES ONLY WHEN SIGNED.

SIGNATURE *Joyce Suttaby* DATE 6-8-95

Goulds Serial # 786D830
Cust: OHM REMEDIATION SERVICES CORP.
P.O. # 1005430
Item # P-241 PROJ. CAMP LBJBUNE
Service: BACKWASH PUMP

ISSUE

DRAWING IS NOT TO SCALE
DIMENSIONS IN INCHES

DRAWN TJA
8-31-94
APPROVED PTM
9-6-94

DRAWING

A05461A

REVISION

0

ISSUE

0



GOULDS PUMPS, INC.

INDUSTRIAL PRODUCTS GROUP
ENGINEERED PRODUCTS DIV.

TAPPED OPENINGS
GROUP MTX/LTX

STUFFING BOX/SEAL CHAMBER GLAND OPTIONS
OPTION FURNISHED WHEN CHECKED

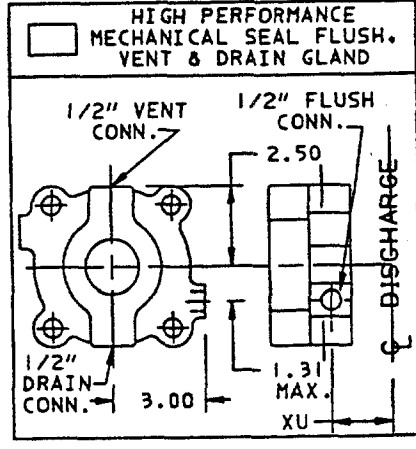
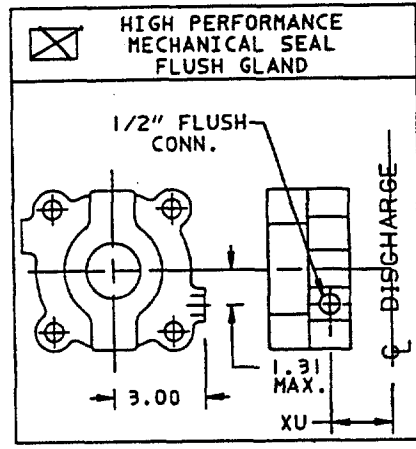
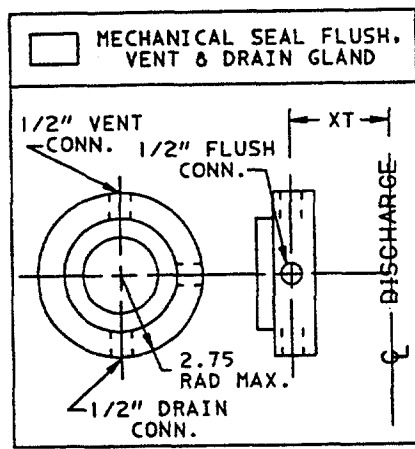
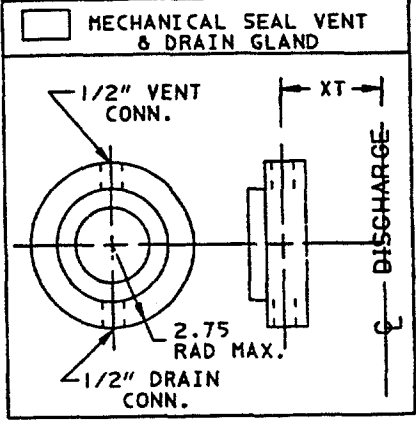
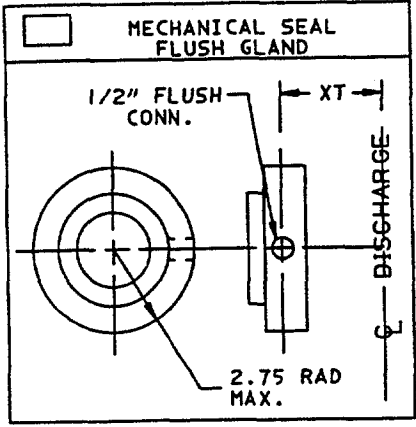
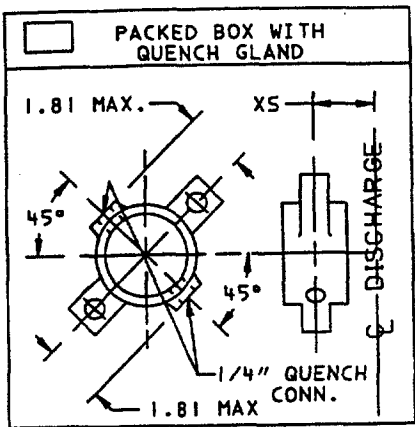

| PUMP MODEL | PUMP DIMENSIONS (MAXIMUM) | | |
|--|---------------------------|-------|-------|
| | XS | XT | XU |
| <input checked="" type="checkbox"/> 3196 | 4.88 | 4.75 | 4.62 |
| 3796: | | | |
| 2X2-10 | 7.12 | 7.00 | 6.81 |
| 3X3-10 | 8.00 | 7.88 | 7.69 |
| 4X4-10 | 8.75 | 8.62 | 8.44 |
| 3X3-13 | 8.00 | 7.88 | 7.69 |
| 4X4-13 | 8.75 | 8.62 | 8.44 |
| 6X6-13 | 13.12 | 13.00 | 12.81 |
| 3996 | 5.38 | 5.25 | 5.12 |
| LF 3196 | 4.88 | 4.75 | 4.62 |
| CV 3196: | | | |
| 2X2-10 | 7.12 | 7.00 | 6.81 |
| 3X3-10 | 7.81 | 7.69 | 7.52 |
| 2X3-13 | 7.69 | 7.56 | 7.36 |
| 3X4-13 | 8.19 | 8.06 | 7.86 |

| GROUP | |
|-------------------------------------|-----|
| <input checked="" type="checkbox"/> | MTX |
| <input type="checkbox"/> | LTX |

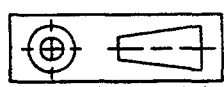

CERTIFIED FOR CONSTRUCTION PURPOSES ONLY WHEN SIGNED.

SIGNATURE *Joyce Sutterby* DATE 6-8-95

Goulds Serial # 786D830
Cust: OHM REMEDIATION SERVICES CORP.
P.O. # 1005430
Item # P-241 PROJ. CAMP LEJEUNE
Service: BACKWASH PUMP

ISSUE

DRAWING IS NOT TO SCALE
DIMENSIONS IN INCHES

DRAWN TJA 09-01-94
CHECKED PTM 09-06-94

DRAWING A05469A

REVISION 0

ISSUE 0

DATE 2-26-81

REV. DATE

4-14-93 ISSUE #1
1-30-91 ISSUE #2
1-7-87 ISSUE #3
10-8-82 ISSUE #1

GOULDS PUMPS, INC.
SENECA FALLS NEW YORK 13148

CENTRIFUGAL PUMP CHARACTERISTICS

RPM 1150 CDS 2928-4

MODEL 3196

SIZE 3x4-10H

IMP. DWG. C00262A01

Steel C00262A02

PATTERN 58009

Steel 58434

EYE AREA 17.5 in²

8 1/4" IMP. DIA.

Goolds Serial # 786D830
Cust: OHM REMEDIATION SERVICES CORP.
P.O. # 1005430
Item # P-241 PROJ. CAMP LEJEUNE
Service: BACKWASH PUMP

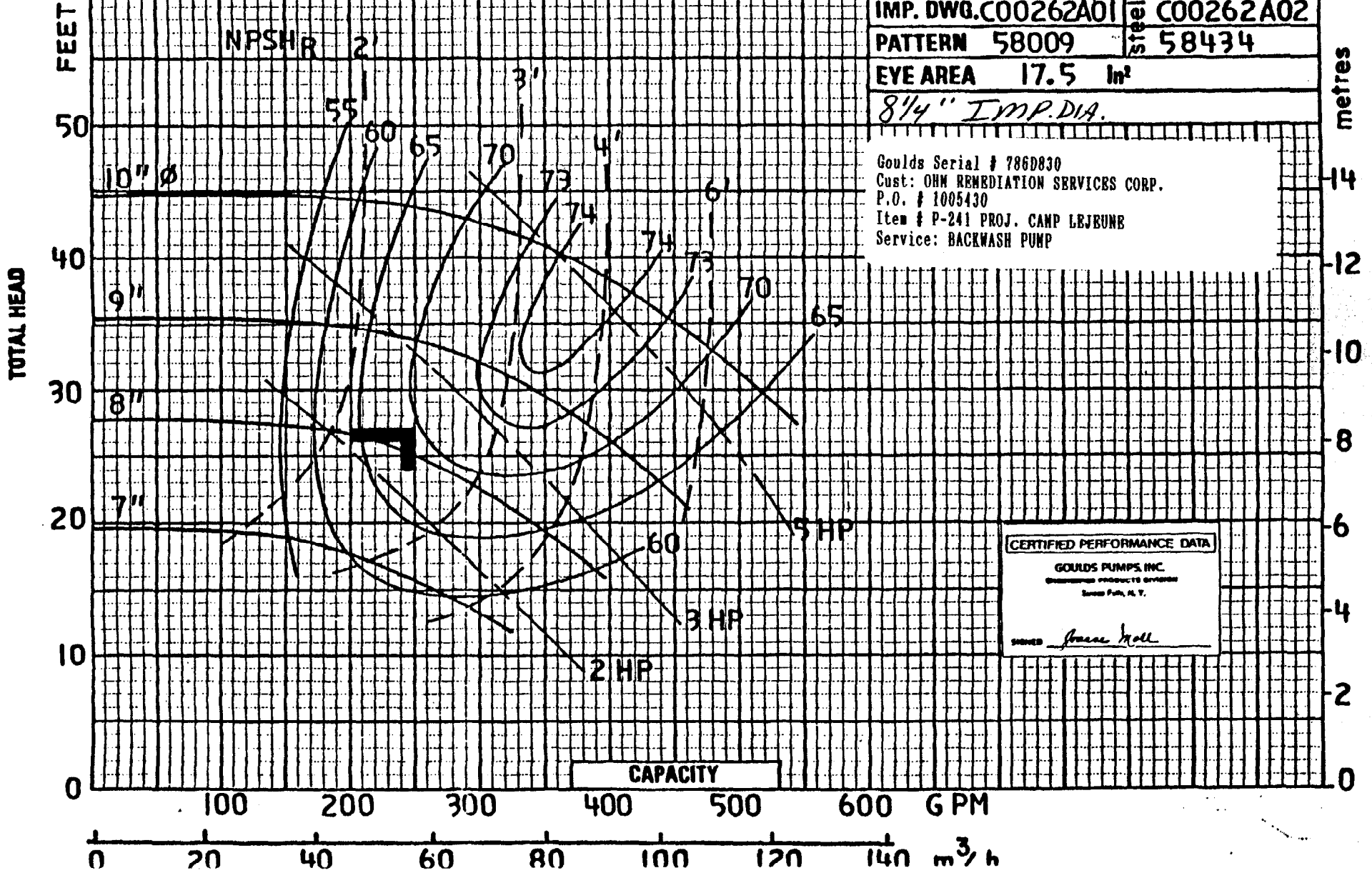

CERTIFIED PERFORMANCE DATA
GOULDS PUMPS, INC.
Centrifugal Products Division
 Seneca Falls, N.Y.
 SIGNED *James Hall*

BI OF MATERIAL
CONSTRUCTION: DUCTILE IRON

| ITEM NO | QTY PER PUMP | PART NAME | MATERIAL |
|---------|--------------|-------------------------|-----------|
| 100 | 1 | CASING | DI |
| 101 | 1 | IMPELLER | 316SS |
| 105 | 2 | LANTERN RING HALF | TEFLON |
| 106 | 1 | STUFFING BOX PKG | NON-ASB |
| 107 | 1 | GLAND | 316SS |
| 108 | 1 | FRAME ADAPTER | DI |
| 112A | 1 | BALL BRG OTBD | STEEL |
| 113A | 1 | PLUG,OIL FILL | STEEL |
| 122 | 1 | SHAFT | STEEL |
| 126 | 1 | SHAFT SLEEVE | 316SS |
| 134 | 1 | BRG HOUSING | CI |
| 136 | 1 | BRG LOCK NUT | STEEL |
| 168A | 1 | BALL BRG INBD | STEEL |
| 184 | 1 | S.B. COVER/SEAL CHAM. | DI |
| 228 | 1 | FRAME | CI |
| 241 | 1 | FRAME FOOT | CI |
| 319 | 1 | SIGHT GLASS | STL/GLASS |
| 332A | 1 | LBYS SEAL OTBD W/O-RING | TFL/GPH |
| 333A | 1 | LBYS SEAL INBD W/O-RING | TFL/GPH |
| 351 | 1 | GASKET-CASE | EPDM-RBR |
| 353 | 2 | STUD-GLAND | 316SS |
| 355 | 2 | NUT GLAND STUD | 304SS |
| 360D | 1 | GASKET-FR-ADPTR | VELLUMOID |
| 361A | 1 | RTNG RING-BRG HSG | STEEL |
| 370 | 8 | H CAP SCR-ADPTR-CASE | STEEL |
| 370B | 4 | H CAP SCR-ADPTR-FR | STEEL |
| 370C | 3 | H TAP BOLT-BRG HSG | STEEL |
| 370D | 3 | H TAP BOLT-IMPLR-ADJ | STEEL |
| 370F | 2 | H CAP SCR-FR-FOOT | STEEL |
| 370H | 2 | STUD-COVER-ADPTR | 304SS |
| 382 | 1 | BRG LOCKWASHER | STEEL |
| 400 | 1 | KEY,SQUARE | STEEL |
| 408A | 1 | MAG. PLUG-OIL DRAIN | STEEL |
| 408J | 1 | PLUG,SIGHT OILER | STEEL |
| 408H | 4 | PLUG,OIL MIST CONN | STEEL |
| 412A | 1 | O-RING IMPELLER | TEFLON |
| 418 | 3 | H TAP BOLT-JACKING | 304SS |
| 423 | 3 | JAM NUT FOR 370D | STEEL |
| 469B | 2 | DOWEL PIN-FR-ADPTR | ALLOY-ST |
| 496 | 1 | O-RING-BRG HSG | BUNA-RBR |
| 497F | 1 | O-RING,OTBD SEAL ROT. | VITON |
| 497G | 1 | O-RING,OTBD SEAL STA. | VITON |
| 497H | 1 | O-RING,INBD SEAL ROT. | VITON |
| 497J | 1 | O-RING,INBD SEAL STA. | VITON |

BOTTLE OILER
OPTION FURNISHED WHEN CHECKED

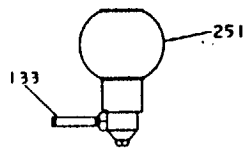

| ITEM NO | NO REQ'D | PART NAME | MAT'L |
|---------|----------|--------------|------------|
| 133 | 1 | PIPE NIPPLE | STEEL |
| 251 | 1 | BOTTLE OILER | ALUM/GLASS |

STANDARD OIL LUBE

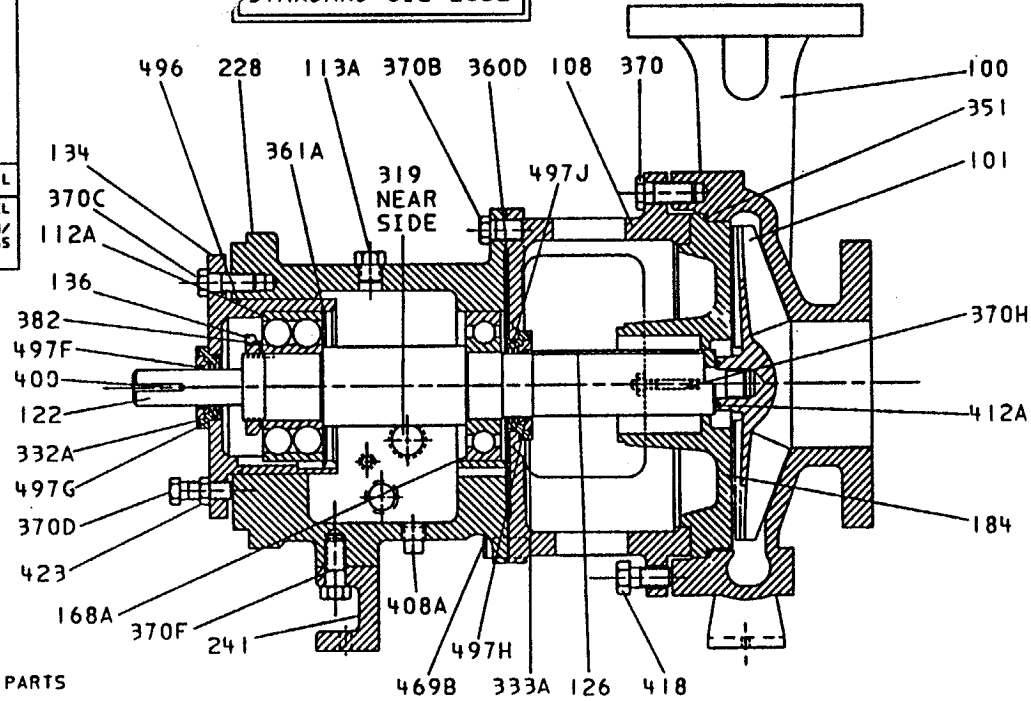

- * RECOMMENDED SPARE PARTS
- Ⓐ ITEM 370 IS QTY 12 FOR 10" CASINGS & QTY 16 FOR 13" CASINGS.
- Ⓑ GLAND BOLTING FOR PACKING GLAND (ITEM 353 & 355) IS QTY 2. FOR MECHANICAL SEAL QTY 4.
- Ⓒ ITEMS NOT ILLUSTRATED.

STUFFING BOX COVER / SEAL CHAMBER OPTIONS - CHECK OPTION REQUIRED

STUFFING BOX

- NONJACKETED (SHOWN)
- JACKETED

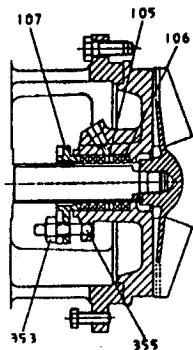

REFER TO SEAL DRAWING NO. 265-24880

TAPER BORE™ PLUS

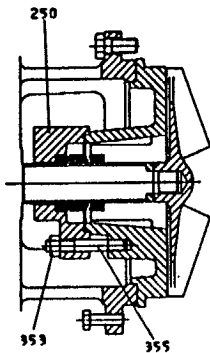

BIG BORE™ STD. FLUSH

- NONJACKETED (SHOWN)
- JACKETED

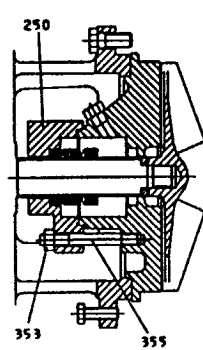

BIG BORE™ W/ INTERNAL BY-PASS

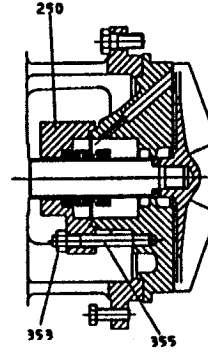

Goulds Serial # 786D830
Cust: OHM REMEDIATION SERVICES CORP.
P.O. # 1005430
Item # P-241 PROJ. CAMP LEJBUNB
Service: BACKWASH PUMP

PUMP CROSS SECTION DRAWING

MODEL 3196MTX



GOULDS PUMPS, INC.

INDUSTRIAL PRODUCTS GROUP
ENGINEERED PRODUCTS DIV.

DRAWN
THO
05/20/91

CHECKED
THO
05/20/91

APPROVED
RAS
06/28/91

THIRD ANGLE
PROJECTION

DRAWING IS NOT TO SCALE

DRAWING
B02917A2

REV.

2

Goulds Serial # 786D830
 Cust: OHM REMEDIATION SERVICES CORP.
 P.O. # 1005430
 Item # P-241 PROJ. CAMP LEJUNB
 Service: BACKWASH PUMP

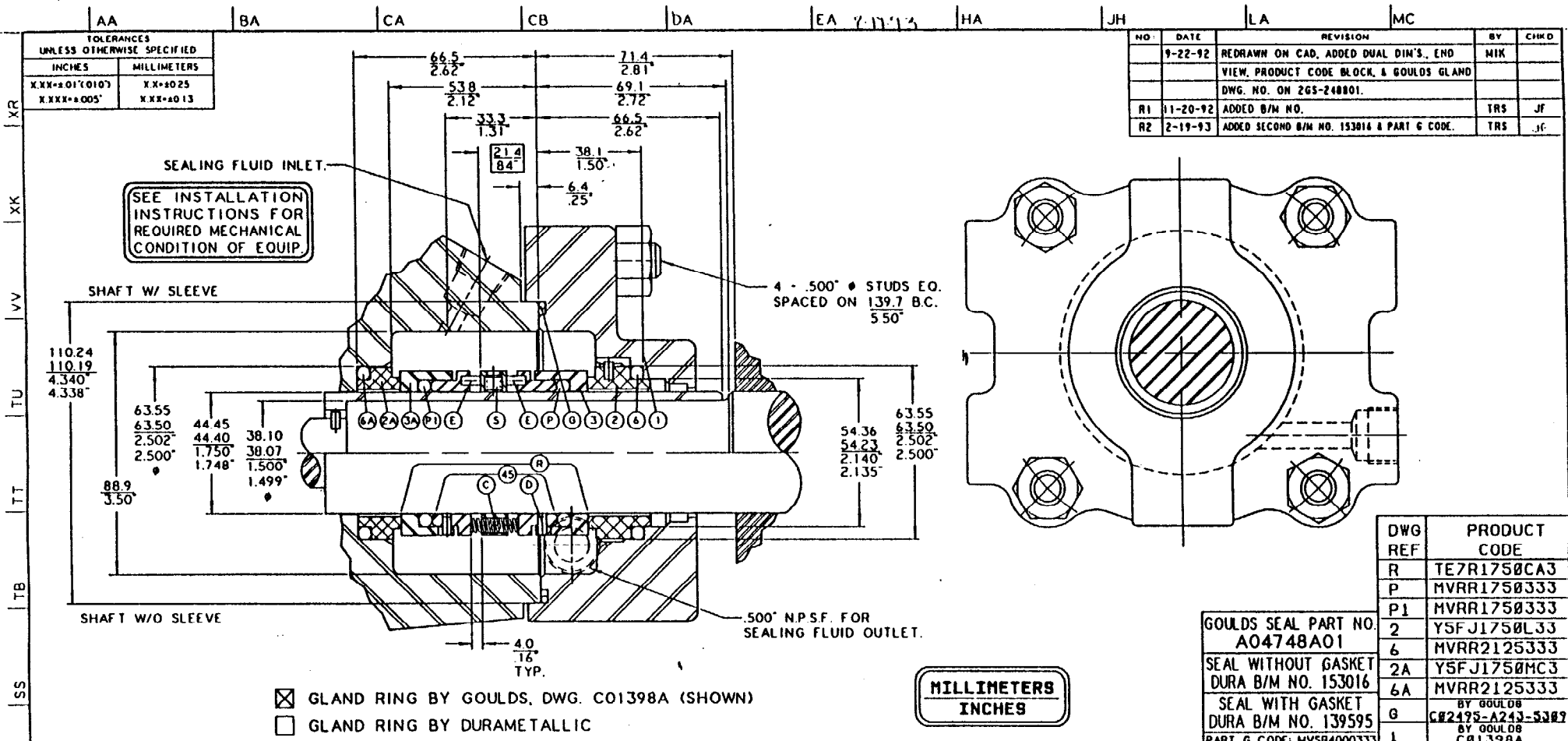

| NO | DATE | REVISION | BY | CHKD |
|---------|----------|--|-----|------|
| 9-22-92 | | REDRAWN ON CAD, ADDED DUAL DIM'S, END VIEW, PRODUCT CODE BLOCK, & GOULDS GLAND DWG. NO. ON 2GS-248801. | MIK | |
| R1 | 11-20-92 | ADDED B/M NO. | TRS | JF |
| R2 | 2-19-93 | ADDED SECOND B/M NO. 153816 & PART 6 CODE. | TRS | JF |

| DWG REF | PRODUCT CODE |
|---------|-------------------------------|
| R | TE7R1750CA3 |
| P | MVRR1750333 |
| P1 | MVRR1750333 |
| 2 | YSFJ1750L33 |
| 6 | MVRR2125333 |
| 2A | YSFJ1750MC3 |
| 6A | MVRR2125333 |
| G | BY GOULDS C#2475-A243-5389 |
| 1 | BY GOULDS C#1398A |

GOULDS SEAL PART NO. A04748A01
 SEAL WITHOUT GASKET DURA B/M NO. 153016
 SEAL WITH GASKET DURA B/M NO. 139595
 PART 6 CODE: MYSR4000333

MILLIMETERS
INCHES

- GLAND RING BY GOULDS, DWG. C01398A (SHOWN)
- GLAND RING BY DURAMETALLIC

| R | ROTAARY UNIT CONSISTING OF: | P | SHAFT PKG. | VITON |
|--|---------------------------------|-------|-------------|-------------------------|
| 3 | SEAL RING <i>TEIN CARB 62-6</i> | P1 | SHAFT PKG. | VITON 1 |
| 3 | SEAL RING <i>TEIN CARB 62-6</i> | 2 | INSERT | NO. 5 CARBON |
| 45 | COMP. UNIT | 6 | INSERT MTG. | VITON |
| C | SPRINGS | 20 SS | 2A | INSERT |
| D | DRIVE PINS | 20 SS | 6A | INSERT MTG. |
| E | SPRING PINS | 20 SS | G | GASKET <i>NON-ASB</i> |
| S | SET SCREWS | 20 SS | 1 | GLAND RING <i>316SS</i> |
| RECOMMENDED SPARE PARTS: 2, 2A, 3, 3A, 6, 6A, C, G, P, P1, S | | | | |

| | |
|--|-------------------|
| CUSTOMER: GOULDS PUMPS, INC., SENECA FALLS, NY | |
| P.O. NO.: | F.O. NO.: |
| USER: | |
| EQUIP. TYPE & SIZE | EQUIP. SERIAL NO. |
| GOULDS 3196 MT & MTX ANSI PLUS PUMPS | 786D830 |
| REFERENCE DWG. NO. | EQUIP. ITEM NO.: |
| C01391A | |
| PRODUCT | PRESSURES |
| WATER | BOX |
| TEMP: 70°F | SUCT.: |
| R.P.M.: 1200 | DISCH.: |
| SP.GR.: 1.00 | |

| | |
|--------------------------|----------------------------------|
| DURA SEAL TYPE | SCALE SIZE |
| DOUBLE INSIDE RO | 1.750" |
| DURAMETALLIC CORPORATION | |
| KALAMAZOO, MICHIGAN | |
| MATL CODE | E U S - - V V |
| SCALE: .72"=1.00" | ORDER PARTS BY B/M NO. SEE ABOVE |
| DATE: 4-29-89 | DATE: 9-28-92 |
| OWN. TC | CHKD: GB |
| APPRD BY: | OWN. PGP |
| FORM DWG: | CHKD: GB |
| DWG NO.: | DWG NO.: |
| 2GS-248801 | 786830#3 |



GOULDS PUMPS, INC.
ENGINEERED PRODUCTS DIVISION

LUBRICANT DATA SHEET

CUSTOMER INFORMATION

EQUIPMENT IDENTIFICATION

Goulds Serial # 786D830
Cust: OHM REMEDIATION SERVICES CORP.
P.O. # 1005430
Item # P-241 PROJ. CAMP LEJEUNE
Service: BACKWASH PUMP

MODEL 3196MTX SIZE 3X4-10H
LUBRICATION OIL
CONST. DI/316SS

| PART LUBRICATED | LUBRICANT | | FILL CAPACITY | CONSUMPT. AMT. / TIME | RECOMMENDED LUBRICANT MFR. & NO. & REMARKS |
|-----------------------|------------------|------------|---------------------------|---|--|
| | TYPE | VISC OSITY | | | |
| BEARING HOUSING FRAME | TURBINE TYPE OIL | ISO VG68 | APPROX. 2.6 PTS (1250 ML) | REFILL APPROXIMATELY EVERY(3) MONTHS OR 2000 HRS. | OIL MUST BE VISIBLE AT CENTER OF SIGHT GLASS |

REV. DATE

| | | | | | | |
|--|--|--|------------|-------------|-------------|------|
| | | | WRITTEN BY | APPROVED BY | DRAWING NO. | REV. |
| | | | DATE | DATE | 196 MTX LDS | 0 |

SHEET 1 OF 1



TYPE SC SPACER COUPLINGS

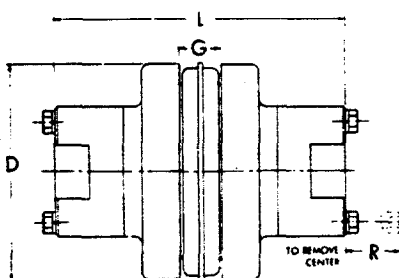
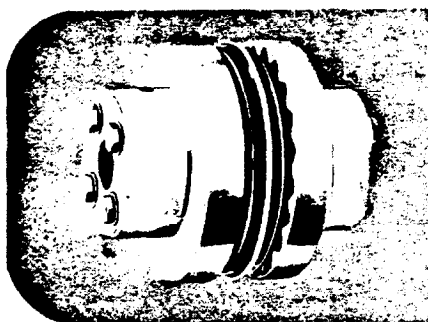

The table below shows assembled dimensions of Sure-Flex Type SC Spacer Couplings. For dimensions of separate components, refer to page 19.

| Coupling Size | Required Distance Between Shafts | Use Flange No. | Use Hub No. | Max. Bore Std. KS | Dimensions | | | | Wt. ⁽²⁾ (lbs.) |
|---------------|----------------------------------|----------------|-------------|----------------------|------------|------------------|--------|--------|---------------------------|
| | | | | | D | L ⁽²⁾ | G | R | |
| 4JSC | 3 1/2 | 4JSC35 | | 1 1/2 ⁽¹⁾ | 2.460 | 5 1/8 | 5/8 | | 2.7 |
| 5SC | 3 1/2 | 5SC35 | 5H | 1 1/8 | 3.250 | 5 1/8 | 3/4 | 9/16 | 4.5 |
| 6SC | 3 1/2 | 6SC35 | 6H | 1 3/8 | 4.000 | 5 1/8 | 7/8 | 3/4 | 7.3 |
| | 4 1/2 | 6SC44 | 6H | 1 3/8 | 4.000 | 6 1/8 | 7/8 | 3/4 | 8.1 |
| | 5 | 6SC50 | 6H | 1 3/8 | 4.000 | 7 1/8 | 7/8 | 3/4 | 8.7 |
| 7SC | 3 1/2 | 7SC35 | 7H | 1 1/2 | 4.625 | 6 1/8 | 1 | 5/8 | 9.9 |
| | 4 1/2 | 7SC44 | 7H | 1 1/2 | 4.625 | 7 1/8 | 1 | 5/8 | 10.8 |
| | 5 | 7SC50 | 7H | 1 1/2 | 4.625 | 7 1/8 | 1 | 5/8 | 11.4 |
| 8SC | 3 1/2 | 8SC35 | 8H | 1 3/8 | 5.450 | 6 3/8 | 1 1/8 | 1 1/16 | 15.2 |
| | | 8SC35-10 | 10H* | 2 3/8 | 5.450 | 8 3/8 | 1 1/8 | 1 3/16 | 23.2 |
| | 4 1/2 | 8SC44 | 8H | 1 3/8 | 5.450 | 7 3/8 | 1 1/8 | 1 3/16 | 16.4 |
| | 5 | 8SC50 | 8H | 1 3/8 | 5.450 | 8 3/8 | 1 1/8 | 1 3/16 | 17.4 |
| | 8SC50-10 | 10H* | 2 3/8 | 5.450 | 9 3/8 | 1 1/8 | 1 3/16 | 27.2 | |
| 9SC | 3 1/2 | 9SC35 | 9H* | 2 1/8 | 6.350 | 7 1/2 | 1 1/8 | 1 1/8 | 18.6 |
| | 4 1/2 | 9SC44 | 9H* | 2 1/8 | 6.350 | 8 1/2 | 1 1/8 | 1 1/8 | 22.2 |
| | 5 | 9SC50 | 9H* | 2 1/8 | 6.350 | 8 1/2 | 1 1/8 | 1 1/8 | 23.2 |
| | | 9SC50-11 | 11H* | 2 1/8 | 6.350 | 10 1/2 | 1 1/8 | 1 1/8 | 40.4 |
| | 7 | 9SC70-11 | 11H* | 2 1/8 | 6.350 | 12 1/2 | 1 1/8 | 1 1/8 | 48.2 |
| | 9SC78-11 | 11H* | 2 1/8 | 6.350 | 13 1/2 | 1 1/8 | 1 1/8 | 51.0 | |
| 10SC | 4 1/2 | 10SC48 | 10H* | 2 3/8 | 7.500 | 9 1/2 | 1 5/8 | 1 3/8 | 37.6 |
| | 5 | 10SC50 | 10H* | 2 3/8 | 7.500 | 9 1/2 | 1 5/8 | 1 3/8 | 38.4 |
| | 7 | 10SC70-13 | 13H* | 3 1/8 | 7.500 | 13 1/2 | 1 5/8 | 1 3/8 | 72.0 |
| | 7 1/2 | 10SC78-13 | 13H* | 3 1/8 | 7.500 | 14 1/2 | 1 5/8 | 1 3/8 | 76.0 |
| | 10 | 10SC100-13 | 13H* | 3 1/8 | 7.500 | 16 1/2 | 1 5/8 | 1 3/8 | 88.0 |
| 11SC | 4 1/2 | 11SC48 | 11H* | 2 3/8 | 8.625 | 10 1/2 | 1 7/8 | 1 3/8 | 54.5 |
| | 5 | 11SC50 | 11H* | 2 3/8 | 8.625 | 10 1/2 | 1 7/8 | 1 3/8 | 54.7 |
| | 7 | 11SC70-14 | 14H | 3 1/8 | 8.625 | 14 1/2 | 1 7/8 | 2 | 86.1 |
| | 7 1/2 | 11SC78-14 | 14H | 3 1/8 | 8.625 | 15 1/2 | 1 7/8 | 2 | 90.3 |
| | 10 | 11SC100-14 | 14H | 3 1/8 | 8.625 | 17 1/2 | 1 7/8 | 2 | 102.7 |
| 12SC | 7 | 12SC70 | 12H* | 2 3/8 | | | | | |
| | | 12SC70-14 | 14H | 3 1/8 | | | | | |
| | 7 1/2 | 12SC78 | 12H* | 2 3/8 | | | | | |
| | | 12SC78-14 | 14H | 3 1/8 | | | | | |
| 10 | 12SC100-14 | 14H | 3 1/8 | | | | | | |
| 13SC | 7 1/2 | 13SC78 | 13H* | 3 1/8 | | | | | |
| 14SC | 7 1/2 | 14SC78 | 14H | 3 1/8 | | | | | |

Coulds Serial # 786D830
 Cust: OHM REMEDIATION SERVICES CORP.
 P.O. # 1005430
 Item # P-241 PROJ. CAMP LBJEUNE
 Service: BACKWASH PUMP

*Short (HS) hub also available. ■ Approximate weight for completely assembled spacer coupling.
 (1) 4JSC35 x 1", has shallow keyseat. (2) "L" dimension and weight will change if one or two short (HS) hubs used.
 Note: Refer to page 19 to order — specify components separately.

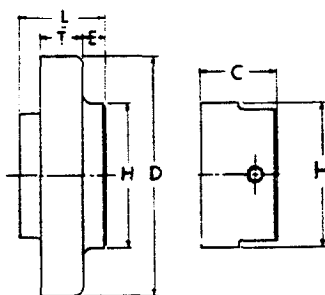
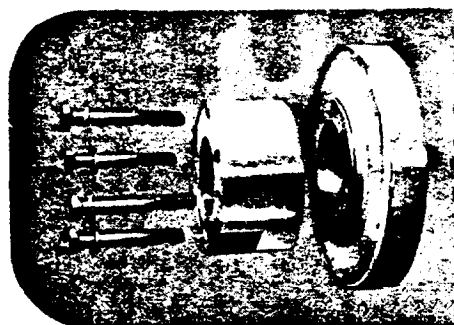

TYPE SC FLANGES AND HUBS

Tables on page 19 provide dimensional information for flanges and hubs used for Spacer Couplings. For assembled dimensions, see table above. Any of the sleeves shown on page 10 may be used.



GOULDS PUMPS, INC.
INDUSTRIAL PRODUCTS GROUP



**GE Motors
& Industrial Systems**

June 15, 1995

**Customer Service Dept
Fort Wayne, IN 46802
(219) 439-2000**

**Customer: GOULDS PUMPS INC
ENGINEERED PRODUCTS DIV
240 FALL ST
SENECA FALLS NY 13148**

**Customer Order.....: 373932
Customer Part.....: 786D828MT**

**GEMIS Reqn / Item.....: 69607511 / 10
GEMIS Job Number.....: 950612247**

Marks: 373932/ 786D828MT

**MODEL NUMBER: 5KS256BC205
Outline Drawing.....: 225B7605AA
Installation manual.....: GEI-56128
Design Code.....: 25TD1006A
Type.....: KS
Frame.....: 256T
Hp.....: 20
Rpm-fl.....: 1765
Phase.....: 3
Volts.....: 230/460
Hz.....: 60
Service Factor.....: 1.15**

**ESTIMATED WEIGHT ...: 332 Lbs (150.60Kg)
Time Rating.....: CONT
Amb-max.....: 40
Insul Class.....: F
Nema Design.....: B
Code.....: G
Amps-fl.....: 45.5/22.8
Nema Eff Nom.....: 93.0
Nema Eff Guar.....: 92.0
Power Factor.....: 89.5
Bearing-de.....: 6309ZZ
Bearing-ode.....: 6307ZZ**

Enclosure.....: Totally Enclosed Fan-Cooled

Additional Motor Data:

**USABLE ON 208V NETWORKS AT 50.5 AMPS
4 POLE**

**Goulds Serial # 786D828-1-2
Cust: OHM REMEDIATION SERVICES CORP.
P.O. # 1005430
Item # P-110A/B PROJ. CAMP LEJEUNE
Service: STRIPPER FEED PUMPS**

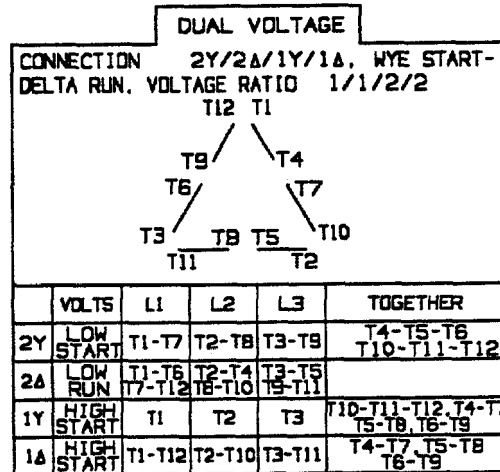

Goulds Serial # 7860828-1-2
 Cust: OHM REMEDIATION SERVICES CORP.
 P.O. # 1005430
 Item # P-110A/B PROJ. CAMP LEJEUNE
 Service: STRIPPER FBBD PUMPS

SIZE B DWG NO 225B7605AA

| REVISIONS | | | |
|-----------|-------------|------|----------|
| REV | DESCRIPTION | DATE | APPROVED |
| | | | |

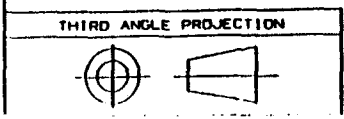
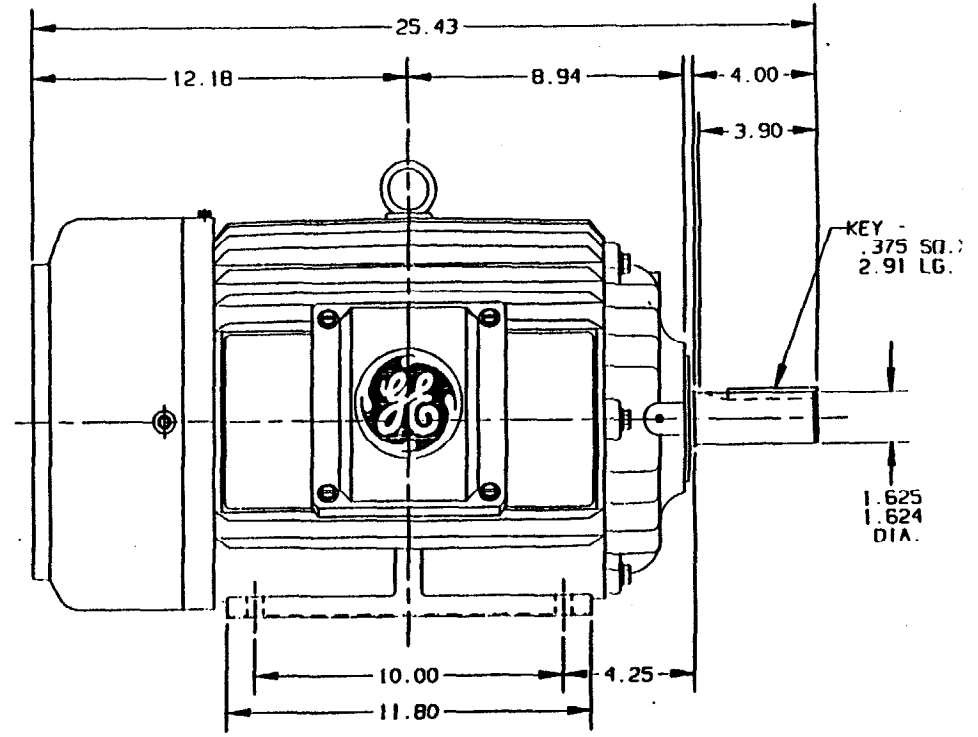
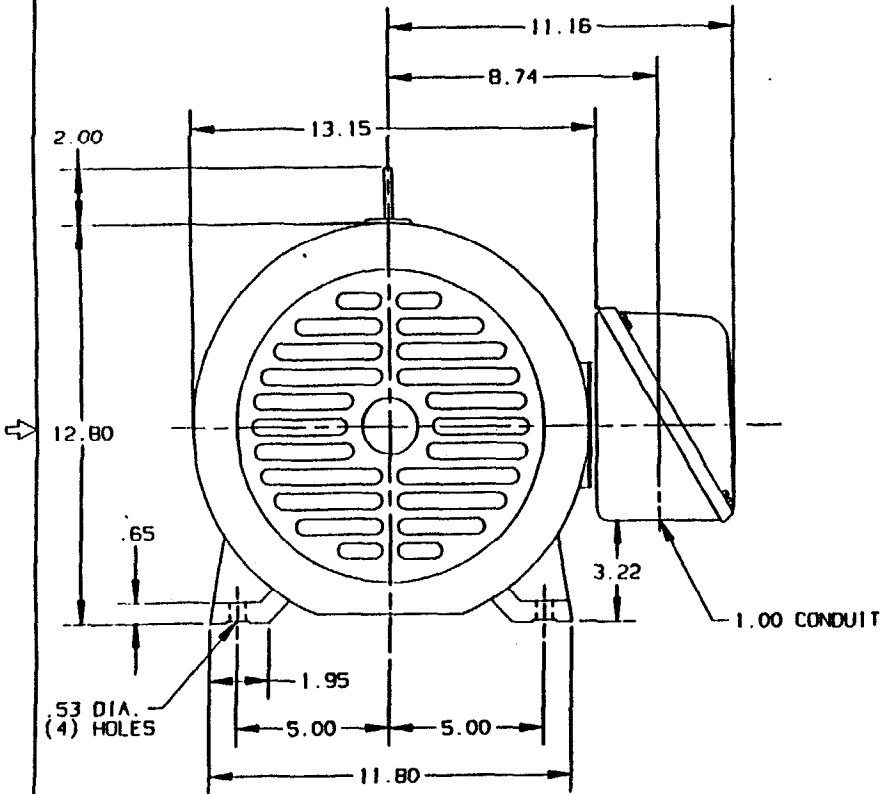

| | | | |
|--|------------------|----------------|---|
| UNLESS OTHERWISE SPECIFIED DIMENSIONS ARE IN INCHES TOLERANCES ON: 2 PL DECIMALS ± 3 PL DECIMALS ± ANGLES ± FRACTIONS ± MATERIAL: | SIGNATURES | DATE | GE Motors Fort Wayne, Indiana |
| | DRAWN R. KOHNE | 08/05/94 | |
| | CHECKED R. KOHNE | 12/12/94 | |
| | ENGRG | | |
| ISSUED | 12/12/94 | OUTLINE | |
| CAD NO. D1250:225B7605AA | SIZE B | FSCM NO | 288T TEFC |
| APPROVED PRACTICES: | | DWG NO | 225B7605AA |



**GE Motors
& Industrial Systems**

June 15, 1995

**Customer Service Dept
Fort Wayne, IN 46802
(219) 439-2000**

**Customer: GOULDS PUMPS INC
ENGINEERED PRODUCTS DIV
240 FALL ST
SENECA FALLS NY 13148**

**Customer Order.....: 373932
Customer Part.....: 786D829MT**

**GEMIS Reqn / Item.....: 69607511 / 20
GEMIS Job Number.....: 950612247**

Marks: 373932/ 786D829MT

**MODEL NUMBER: 5KS284BC205
Outline Drawing.....: 225B7606AA
Installation manual.....: GEI-56128
Design Code.....: 28TD1005A
Type.....: KS
Frame.....: 284T
Hp.....: 25
Rpm-fl.....: 1765
Phase.....: 3
Volts.....: 230/460
Hz.....: 60
Service Factor.....: 1.15**

**ESTIMATED WEIGHT ..: 429 Lbs (194.59Kg)
Time Rating.....: CONT
Amb-max.....: 40
Insul Class.....: F
Nema Design.....: B
Code.....: G
Amps-fl.....: 58.0/29.0
Nema Eff Nom.....: 93.6
Nema Eff Guar.....: 92.4
Power Factor.....: 87.5
Bearing-de.....: 6311ZZ
Bearing-ode.....: 6310ZZ**

Enclosure.....: Totally Enclosed Fan-Cooled

Additional Motor Data:

**USABLE ON 208V NETWORKS AT 64.0 AMPS
4 POLE**

Goulds Serial # 786D829-1-2
Cust: OHM REMEDIATION SERVICES CORP.
P.O. # 1005430
Item # P-220A/B PROJ. CAMP LEJBUNE
Service: GAC FEED PUMPS

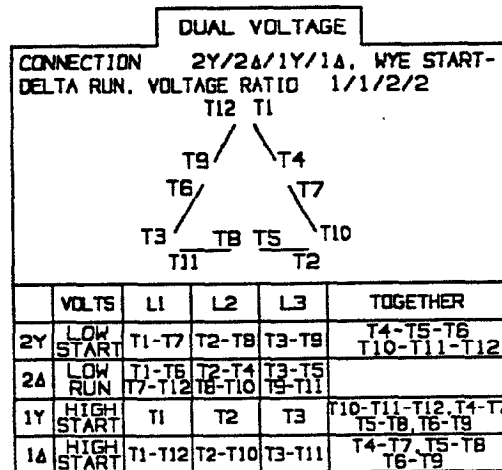



**GE Motors
& Industrial Systems**

June 15, 1995

**Customer Service Dept
Fort Wayne, IN 46802
(219) 439-2000**

**Customer: GOULDS PUMPS INC
ENGINEERED PRODUCTS DIV
240 FALL ST
SENECA FALLS NY 13148**

**Customer Order: 373932
Customer Part: 786D829MT**

**GEMIS Reqn / Item: 69607511 / 20
GEMIS Job Number: 950612247**

Marks: 373932/ 786D829MT

**MODEL NUMBER: 5KS284BC205
Outline Drawing: 225B7606AA
Installation manual: GEI-56128
Design Code: 28TD1005A
Type: KS
Frame: 284T
Hp: 25
Rpm-fl: 1765
Phase: 3
Volts: 230/460
Hz: 60
Service Factor: 1.15**

**ESTIMATED WEIGHT ...: 429 Lbs (194.59Kg)
Time Rating: CONT
Amb-max: 40
Insul Class: F
Nema Design: B
Code: G
Amps-fl: 58.0/29.0
Nema Eff Nom: 93.6
Nema Eff Guar: 92.4
Power Factor: 87.5
Bearing-de: 6311ZZ
Bearing-ode: 6310ZZ**

Enclosure: Totally Enclosed Fan-Cooled

Additional Motor Data:

**USABLE ON 208V NETWORKS AT 64.0 AMPS
4 POLE**

**Goulds Serial # 786D829-1-2
Cust: OHM REMEDIATION SERVICES CORP.
P.O. # 1005430
Item # P-220A/B PROJ. CAMP LEJEUNE
Service: GAC PEBD PUMPS**

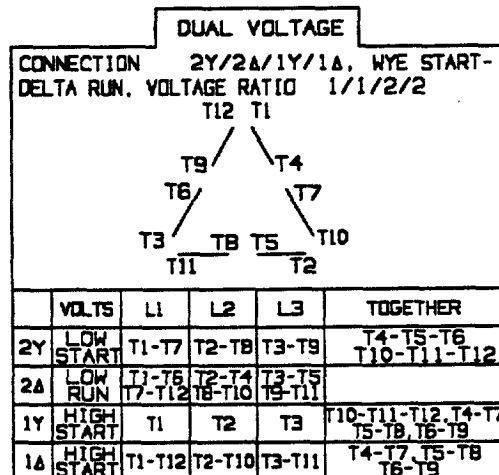

Goulds Serial # 7860829-1-2
 Cust: OHM REMEDIATION SERVICES CORP.
 P.O. # 1005430
 Item # P-220A/B PROJ. CAMP LEJUNE
 Service: GAC FBBD PUMPS

SIZE B DWG NO 225B7606AA SH 1 REV

| REVISIONS | | | |
|-----------|-------------|------|----------|
| REV | DESCRIPTION | DATE | APPROVED |
| | | | |

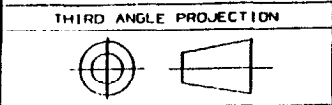
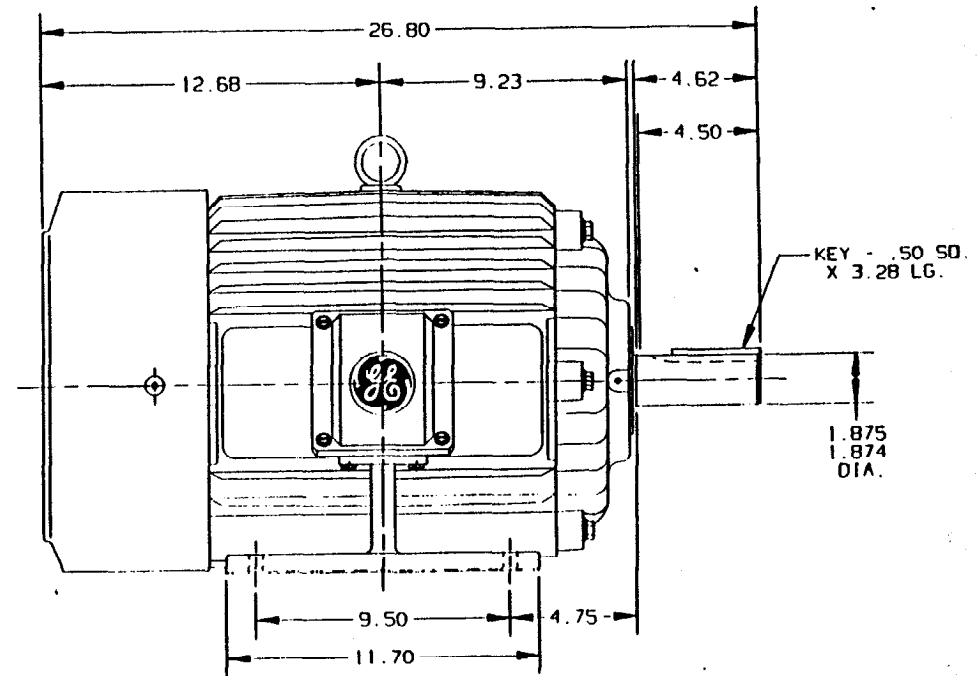
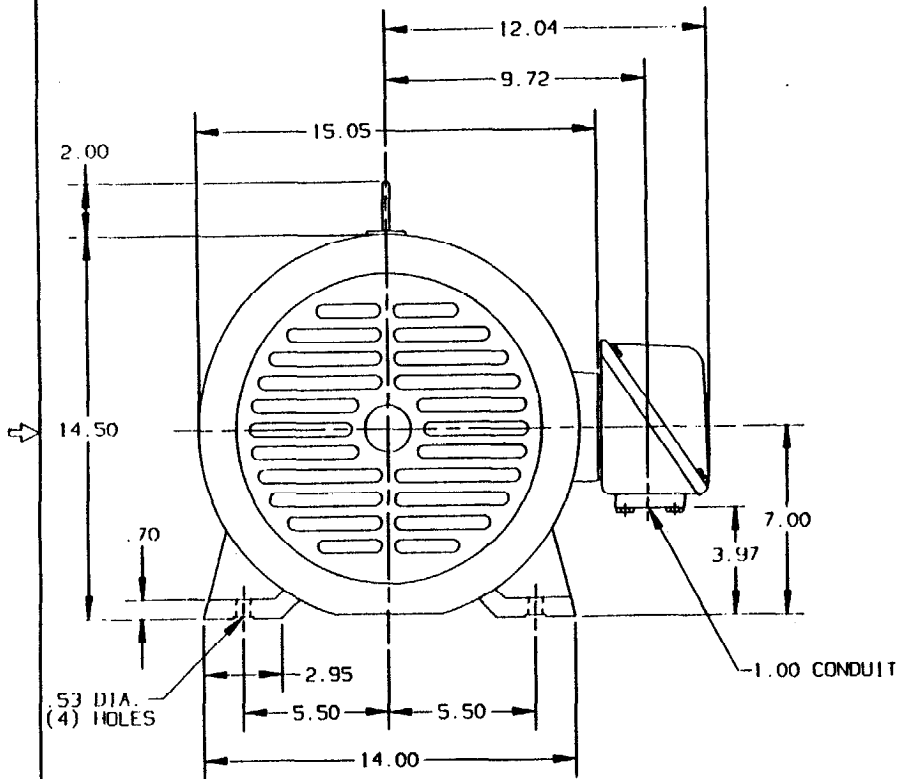

| | | |
|----------------------------|------------------|----------|
| UNLESS OTHERWISE SPECIFIED | SIGNATURES | DATE |
| DIMENSIONS ARE IN INCHES | DRAWN R. KUHNE | 12/09/94 |
| TOLERANCES ON: | CHECKED R. KUHNE | 12/12/94 |
| 2 PL DECIMALS : | ENGRG | |
| 3 PL DECIMALS : | ISSUED | 12/12/94 |
| ANGLES : | | |
| FRACTIONS : | | |
| MATERIAL : | | |
| APPLIED PRACTICES | CAD NO. | |
| | Q1280:225B7606AA | |

GE Motors Fort Wayne, Indiana

OUTLINE

284T TEFC

SIZE B FSCM NO DWG NO 225B7606AA

SCALE 22 SHEET 1 OF 1

DISTR TO



**GE Motors
& Industrial Systems**

June 15, 1995

**Customer Service Dept
Fort Wayne, IN 46802
(219) 439-2000**

**Customer: GOULDS PUMPS INC
ENGINEERED PRODUCTS DIV
240 FALL ST
SENECA FALLS NY 13148**

**Customer Order.....: 373932
Customer Part.....: 786D830MT**

**GEMIS Reqn / Item.....: 69607511 / 30
GEMIS Job Number.....: 950612247**

Marks: 373932/ 786D830MT

**MODEL NUMBER: 5KS213BC305
Outline Drawing.....: 225B7602AA
Installation manual.....: GEI-56128
Design Code.....: 21TD3005A
Type.....: KS
Frame.....: 213T
Hp.....: 3
Rpm-fl.....: 1165
Phase.....: 3
Volts.....: 230/460
z.....: 60
Service Factor.....: 1.15**

**ESTIMATED WEIGHT ..: 139 Lbs (63.05Kg)
Time Rating.....: CONT
Amb-max.....: 40
Insul Class.....: F
Nema Design.....: B
Code.....: K
Amps-fl.....: 8.3/4.2
Nema Eff Nom.....: 88.5
Nema Eff Guar.....: 87.0
Power Factor.....: 76.0
Bearing-de.....: 6308ZZ
Bearing-ode.....: 6306ZZ**

Enclosure.....: Totally Enclosed Fan-Cooled

Additional Motor Data:

**USABLE ON 208V NETWORKS AT 9.2 AMPS
6 POLE**

Goulds Serial # 786D830
Cust: OHM REMEDIATION SERVICES CORP.
P.O. # 1005430
Item # P-241 PROJ. CAMP LEJBUNE
Service: BACKWASH PUMP

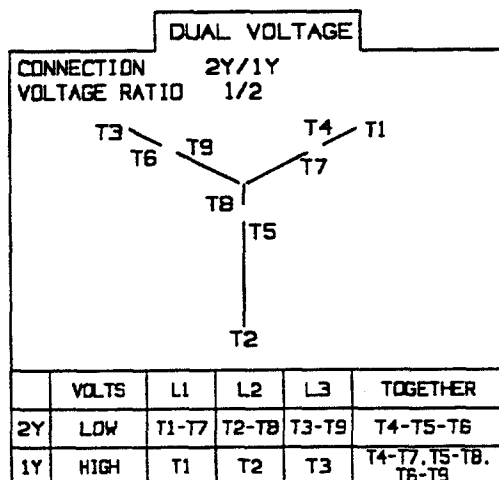



**GE Motors
& Industrial Systems**

June 15, 1995

**Customer Service Dept
Fort Wayne, IN 46802
(219) 439-2000**

**Customer: GOULDS PUMPS INC
ENGINEERED PRODUCTS DIV
240 FALL ST
SENECA FALLS NY 13148**

**Customer Order.....: 373932
Customer Part.....: 786D830MT**

**GEMIS Reqn / Item.....: 69607511 / 30
GEMIS Job Number.....: 950612247**

Marks: 373932/ 786D830MT

**MODEL NUMBER: 5KS213BC305
Outline Drawing.....: 225B7602AA
Installation manual.....: GEI-56128
Design Code.....: 21TD3005A
Type.....: KS
Frame.....: 213T
Hp.....: 3
Rpm-fl.....: 1165
Phase.....: 3
Volts.....: 230/460
Hz.....: 60
Service Factor.....: 1.15**

**ESTIMATED WEIGHT ...: 139 Lbs (63.05Kg)
Time Rating.....: CONT
Amb-max.....: 40
Insul Class.....: F
Nema Design.....: B
Code.....: K
Amps-fl.....: 8.3/4.2
Nema Eff Nom.....: 88.5
Nema Eff Guar.....: 87.0
Power Factor.....: 76.0
Bearing-de.....: 6308ZZ
Bearing-ode.....: 6306ZZ**

Enclosure: Totally Enclosed Fan-Cooled

Additional Motor Data:

**USABLE ON 208V NETWORKS AT 9.2 AMPS
6 POLE**

Goulds Serial # 786D830
Cust: OHM REMEDIATION SERVICES CORP.
P.O. # 1005430
Item # P-241 PROJ. CAMP LEJEUNE
Service: BACKWASH PUMP

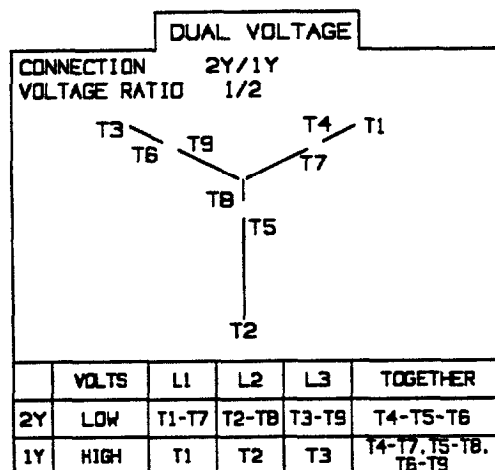

Goulds Serial # 786D830
 Cust: OHM REMEDIATION SERVICES CORP.
 P.O. # 1005430
 Item # P-241 PROJ. CAMP LEJEUNE
 Service: BACKWASH PUMP

DWG NO 225B7602AA

| REVISIONS | | | |
|-----------|-------------|------|----------|
| REV | DESCRIPTION | DATE | APPROVED |
| | | | |

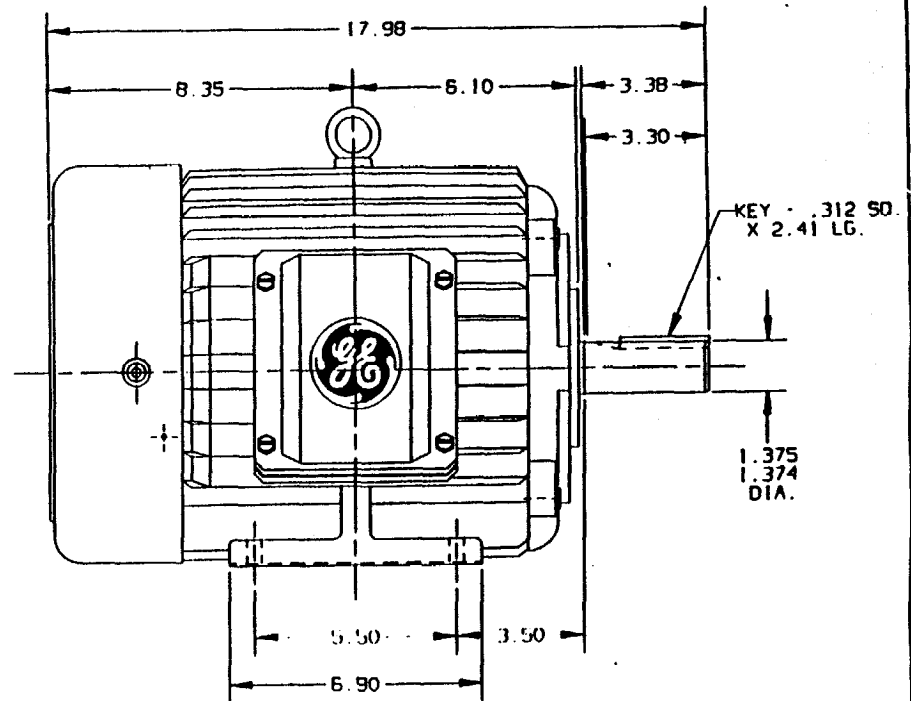
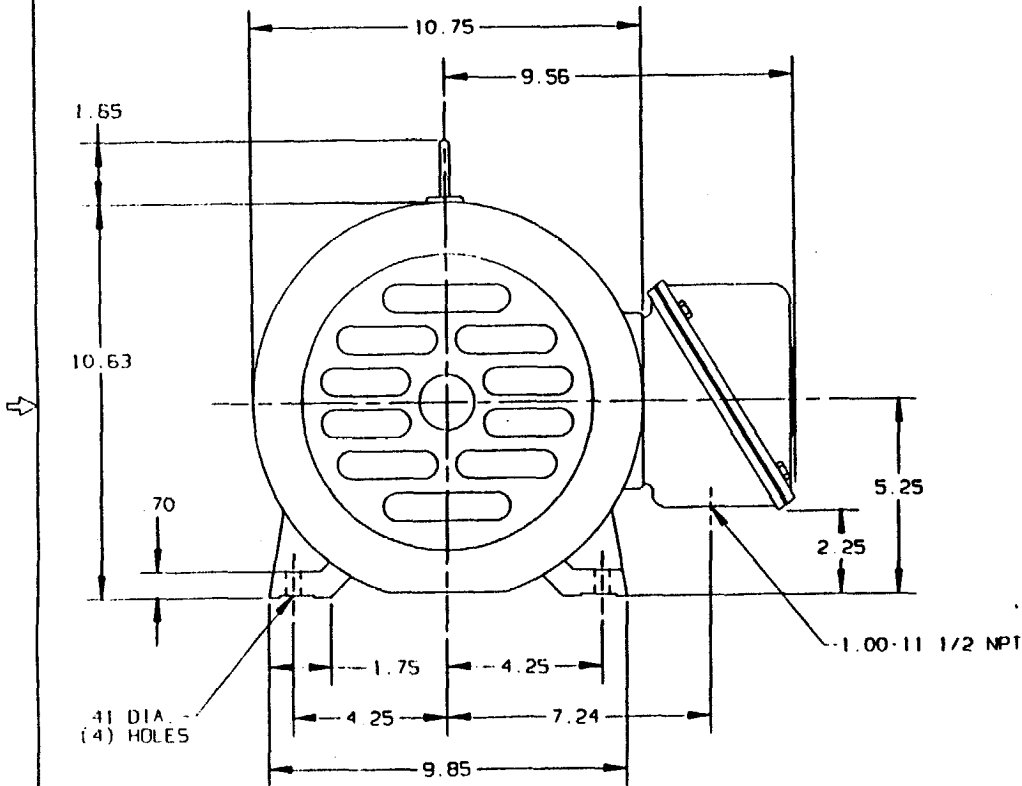

| | | |
|--|------------------|----------|
| UNLESS OTHERWISE SPECIFIED | SIGNATURES | DATE |
| DIMENSIONS ARE IN INCHES | DRAWN R. KOENE | 09-02-94 |
| TOLERANCES UNLESS OTHERWISE SPECIFIED: | CHECKED R. KOENE | 12-12-94 |
| 2 PL. DECIMALS | ENG'G | |
| 3 PL. DECIMALS | ISSUED | 12-12-94 |
| FRACTIONS | | |
| MATERIAL: | | |
| APPLIED PRACTICES: | CAD NO. | |
| | DX10: 225B7602AA | |

GE Motors Fort Wayne, Indiana

OUTLINE

21ST TEFC

SIZE B FSCM NO. DWG NO. 225B7602AA

SCALE .3 SHEET 1 OF 1

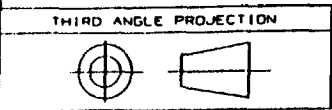

DISTR TO

Goulds Serial # 786D829-1-2
 Cust: OHM REMEDIATION SERVICES CORP.
 P.O. # 1005430
 Item # P-220A/B PROJ. CAMP LEJUNR
 Service: GAC PEBD PUMPS

SIZE B DWG NO 225B7606AA SH 1 REV

| REVISIONS | | | |
|-----------|-------------|------|----------|
| REV | DESCRIPTION | DATE | APPROVED |
| | | | |

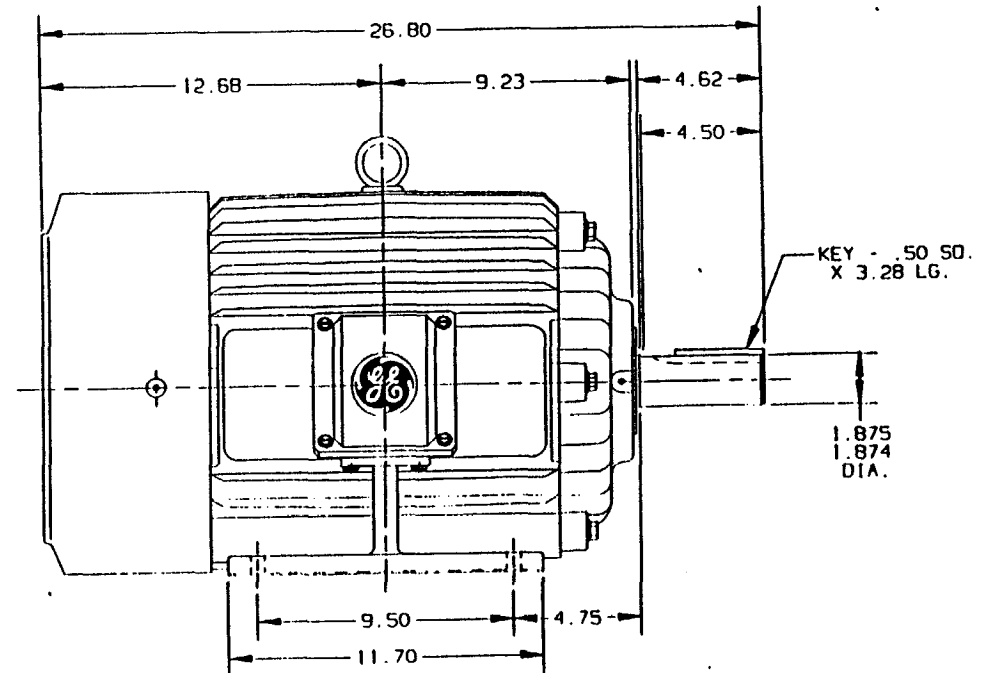
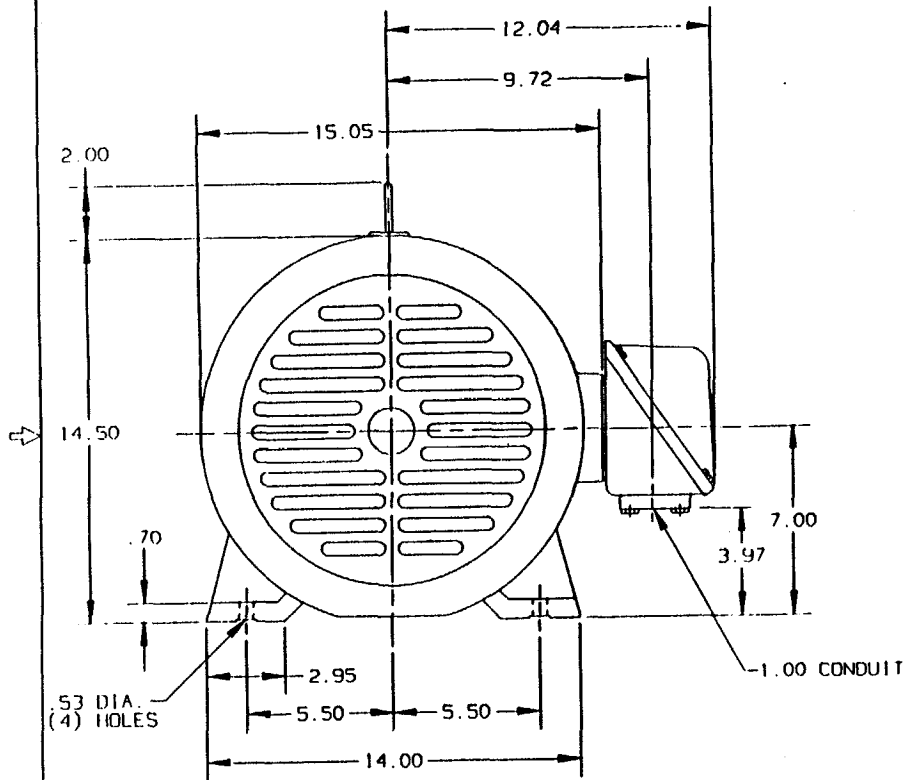

| UNLESS OTHERWISE SPECIFIED | SIGNATURES | DATE |
|--|-------------------------------|----------|
| DIMENSIONS ARE IN INCHES | DRAWN R. KIRNE | 12/09/94 |
| TOLERANCES UNLESS OTHERWISE SPECIFIED: | CHECKED R. KIRNE | 12/12/94 |
| 3 PL. DECIMALS : | ENGRG | |
| 2 PL. DECIMALS : | ISSUED | 12/12/94 |
| 1 PL. DECIMALS : | | |
| FRACTIONS : | | |
| MATERIAL : | | |
| APPROVED: | CAD NO. DWG NO: 225B7606AA | |

GE Motors
 Fort Wayne, Indiana

OUTLINE
 284T TEFC

SIZE B FSCM NO
 DWG NO 225B7606AA
 SCALE .22 SHEET 1 OF 1

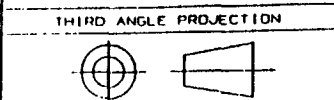

DISTR TO



Motor Installation and Maintenance
All Enclosures - Frames 143 - 449 - Single and Polyphase - Ball Bearing

Warning

Safe Motor Operation

High voltage and rotating parts of electrical machinery can cause serious or fatal injury. Its installation, operation and maintenance should be performed by qualified personnel only. Familiarization with NEMA MG2 Safety Standard for Construction and Guide for Selection, Installation and Use of Fractional and Integral Motors, the National Electrical Code and sound local practices is recommended. For equipment covered by these instructions, it is important to observe safety precautions to protect personnel from possible injury. Personnel should be instructed to:

Avoid contact with energized circuits. Disconnect all power sources before attempting maintenance or repair.

Avoid contact with rotating parts and be sure that shaft key is fully captive before motor is energized.

Avoid contact with the start or run capacitors in single-phase motors until a safe discharge procedure has been followed.

Act with care and in accordance with prescribed procedures in handling, fitting, installing, operating and maintaining the equipment.

Do not lift motor and driven equipment with motor lifting means. If eyebolts are used for lifting motors, they must be securely tightened and the direction of the lift must not exceed a 15 degree angle with the shank of the eyebolt.

Do not use motors with automatic thermal protection where unexpected starting of equipment might be hazardous to personnel. Provide proper safeguards for personnel against possible failure of motor mounted brake, particularly on applications involving overhauling loads.

Safe maintenance practices and qualified personnel are imperative. Before initiating maintenance procedures, be sure that all power sources are disconnected from the machine and accessories to avoid electrical shock and personal injury from rotating parts. If a high potential insulation test is required, procedures and precautions outlined in NEMA Standards MG1 should be followed.

Failure to properly ground motor may cause serious injury to personnel. Grounding should be in accordance with the National Electrical Code and consistent with sound local practice.

Installation

I. Location

- a) **Drip-proof motors** are used in a well ventilated place reasonably free of dirt and moisture.
- b) **Standard enclosed motors** are used where they are exposed to dirt, moisture and most outdoor conditions.
- c) **Severe-duty enclosed motors** are used in highly corrosive or excessively moist areas.
- d) **Explosion-proof motors** bearing the Underwriters' Laboratories label designating the motor U/L Class and Group as defined in the National Electrical Code are designed for operation in areas classified by local authorities as hazardous in accordance with standards set forth in that Code.

II. Mounting

- a) Mount motors securely on a firm, flat base. Grout-in larger motors, if necessary. Ball bearing motors can be sidewall or ceiling mounted. Ball bearing motors in 143 - 326 frame ratings can be vertically mounted. The standard transition and/or sliding bases are suitable for floor mounting. For other locations, check the factory for base recommendations. For motors having bolt-on bases shipped not assembled, refer to paragraph 'c' for assembly instructions before motors are put in service.

CAUTION: Remove drain plugs from the frame or endshields of enclosed motors used outdoors or in other high moisture areas.

- b) Align motors accurately. For direct drive, use flexible couplings if possible. For drive recommendations, consult drive or equipment manufacturers or GE.
- c) For base assembly and motor mounting, the bolts must be carefully tightened to prevent changes in alignment and possible damage to the equipment. It is recommended that a washer be used under each nut or bolt head to get a secure hold on the motor feet; or, as an alternative, flanged nuts or bolts may be used. The recommended tightening torques for medium carbon steel bolts, identified by three radial lines at 120 degrees on the head are:

| Bolt Size | | Recommended Torque in Ft.-lb. (N-M) | | | |
|-----------|----------|-------------------------------------|-------|---------|-------|
| Inch | (Metric) | Minimum | | Maximum | |
| 1/4 | (M6) | 7 | (9) | 11 | (15) |
| 5/16 | (M8) | 14 | (19) | 21 | (28) |
| 3/8 | (M10) | 25 | (34) | 37 | (50) |
| 1/2 | (M12) | 60 | (81) | 90 | (122) |
| 5/8 | (M16) | 120 | (163) | 180 | (244) |
| 3/4 | (M20) | 210 | (285) | 320 | (433) |

NOTE: For low carbon steel bolts, use 50% of the above recommended tightening torques. There are no ID marks on low carbon steel bolts.

- d) When bases are removed on enclosed motors, the enclosure must be maintained by plugging the bolt holes with plastic plugs from Kit No. 1821BPK1. **Warning: Do not replace the bolts in the frame with the base removed.**
- e) Tighten belts only enough to prevent slippage. Belt speed should not exceed 5000 feet per minute.
- f) The application of pulleys, sheaves, sprockets and gears on motor shaft is shown in NEMA Standard MG1-14.07. The application of the V-belts dimensions to alternating current motors is shown in MG1-14.24A. V-belt sheave pitch diameters should not be less than the values shown in Table 1 on page 3.
Sheave ratios greater than 5:1 and center-to-center distances less than the diameter of the large sheave should be referred to the Company.
- g) On motors with dual mounting holes, use the holes indicated per the drawing at right.

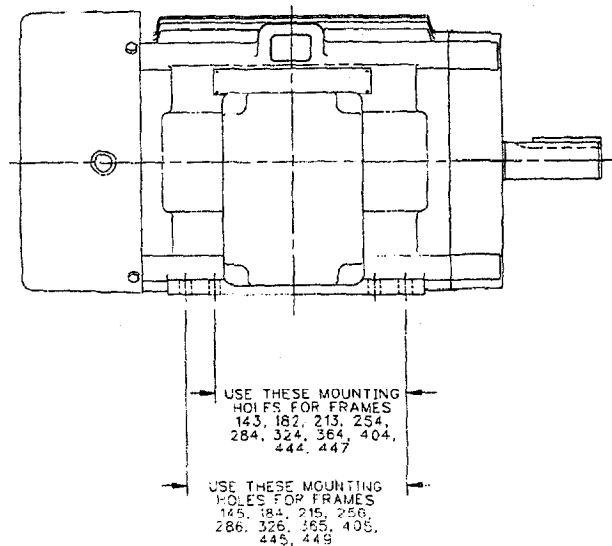

Table 1. V-belt Sheave Diameters (Minimum in Inches)

| Horsepower | | | | Conventional | Narrow |
|-------------------------|-------|-------|-------|----------------|--------------|
| Synchronous Speed (RPM) | | | | A, B, C, D, E* | 3V, 5V, 8VΔ |
| 3600 | 1800 | 1200 | 900 | Pitch Dia. | Outside Dia. |
| 1.5 | 1 | .75 | .50 | 2.2 | 2.2 |
| 2-3 | 1.5-2 | 1 | .75 | 2.4 | 2.4 |
| — | 3 | 1.5 | 1 | 2.4 | 2.4 |
| — | — | 2 | 1.5 | 2.4 | 2.4 |
| 5 | — | — | — | 2.6 | 2.4 |
| 7.5-10.0 | 5-7.5 | 3-5 | 2-3 | 3.0 | 3.0 |
| 15 | 10 | 7.5 | 5 | 3.8 | 3.8 |
| 20-25 | 15 | 10 | 7.5 | 4.4 | 4.4 |
| — | 20 | 15 | 10 | 4.6 | 4.4 |
| — | 25 | — | — | 5.0 | 4.4 |
| — | 30 | 20 | 15 | 5.4 | 5.2 |
| — | 40 | 25 | 20 | 6.0 | 6.0 |
| — | 50 | 30-40 | 25-30 | 6.8 | 6.8 |
| — | 60 | — | — | 7.4 | 7.4 |
| — | — | 50 | 40 | 8.2 | 8.2 |
| — | 75 | — | — | 9.0 | 8.6 |
| — | — | 60 | — | 9.0 | 8.0 |
| — | — | — | 50 | 9.0 | 8.4 |
| — | 100 | — | — | 10.0 | 8.6 |
| — | — | 75 | 60 | 10.0 | 10.0 |
| — | 125 | — | — | 11.5 | 10.5 |
| — | — | 100 | — | 11.0 | 10.0 |
| — | — | — | 75 | 10.5 | 9.5 |
| — | 150 | — | — | — | 9.5 |
| — | — | 125 | 100 | 12.5 | 12.0 |
| — | 200 | — | — | — | 13.2 |

* Maximum sheave width = 2(N-W) - 1/4 inch where N-W is the approximate usable shaft length.
 Δ Maximum sheave width = N-W.

III. Power Supply and Connections

- a) **Nameplate voltage and frequency** should agree with power supply. Motors will operate satisfactorily on line voltage within $\pm 10\%$ of the nameplate value or frequency within $\pm 5\%$, combined variation not to exceed \pm
- b) **Dual voltage motors** can be connected for the desired voltage using instructions on nameplate or connection diagram.
- c) **Wiring of motor, control, overload protection and grounding** should meet the National Electrical Code and local building codes.

Select wire size from the following table to help avoid voltage drop in the branch circuit of single-phase motors.

Individual Branch Circuits for Single-phase Motors

| Motor Hp | Volts | Max. * Fuse Amps | Minimum Size Wire Gauge for Branch Circuit Lengths in Feet | | | |
|----------|-------|------------------|--|-----|-----|-----|
| | | | 0-5 | 100 | 200 | 500 |
| .75 | 230 | 25 | 14 | 12 | 10 | 6 |
| | 115 | 45 | 12 | 8 | 6 | 2 |
| 1 | 230 | 25 | 14 | 14 | 12 | 8 |
| | 115 | 50 | 12 | 8 | 6 | — |
| 1.5 | 230 | 30 | 14 | 12 | 10 | 6 |
| | 115 | 60 | 10 | 6 | 4 | — |
| 2 | 230 | 40 | 14 | 12 | 8 | 4 |
| | 115 | 80 | 10 | 6 | — | — |
| 3 | 230 | 60 | 12 | 10 | 8 | 4 |
| | 115 | 110 | 8 | 8 | — | — |
| 5 | 230 | 90 | 10 | 8 | 6 | 2 |
| | 230 | 125 | 8 | 6 | — | — |

* Value based on National Electrical Code.

IV. Thermal Protectors

- a) **Thermally-protected motors** have those words on the nameplate and have built-in protection against dangerous overheating.
 - b) **Manual-reset protectors** are reset (after motor cools) by pressing external reset button.
 - c) **Automatic-reset protectors** (no external button) reset automatically after motor cools.
- Warning:** Where unexpected starting would be dangerous to personnel, do not use automatic reset protection.

Operation

- a) **Dry out motors** thoroughly which have been stored in a damp location before operating. Do not exceed a temperature of 85°C (185F) in drying.
- b) **Operate at no load** to check rotation and for free running. To reverse rotation:
Three phase - interchange leads T1 and T3.
One phase - follow the motor connection nameplate or label.
- c) **Operate under load** for an initial period of at least one hour to observe whether any unusual noise or hot spots develop.
- d) **Check operating current** against the nameplate current. Do not exceed the value of the nameplate amperes multiplied by the service factor (if any) under continuous load.
- e) **208 Volt system.** When a 230/460 Volt motor with a nameplate which states "usable at 200V, __Hp, __Amps, 1.0 SF" is operated on a 208 Volt system, the motor slip will increase approximately 30% and the motor locked-rotor, pull-up and breakdown torque values will be reduced by approximately 20 to 30%.
Therefore, it should be determined by the user that the motor will start and accelerate the connected load without injurious heating and that the breakdown torque is adequate for the application.

Maintenance

I. Inspection

- a) **Inspect motor** at regular intervals. Keep motor clean and ventilating openings clear.

II. Lubrication

- a) **Ball bearing motors** are adequately lubricated at the factory. Motors with regreasing facilities should be relubricated at intervals consistent with type of service (see Table 2 on page 5) to provide maximum bearing life. Excessive or too frequent lubrication may damage motor.
- b) **Relubricate dripproof motors** with GE grease D6A2C5 or any Lithium Soap thickened grease unless special grease is specified on the nameplate.
Relubricate totally enclosed motors with GE grease D6A2C14 or any Polyurea thickened grease unless a special grease is specified on the nameplate.
Relubricate while the motor is warm with the shaft stationary for safety and best purging of old grease.
Warning: If lubrication is performed with the motor running, stay clear of rotating parts.
- c) **Dripproof Motors.** On the drive end and opposite drive end of motors with pipe plugs, insert a lubrication fitting. Remove the other plug for grease relief of all motors. Clean grease relief opening of any hardened grease. Be sure fittings are clean and free of dirt. Using a low-pressure, hand-operated grease gun, pump in clean recommended grease until new grease appears at the relief hole. After lubricating, allow the motor to run for ten minutes before replacing relief plug.
- d) **Totally Enclosed Fan Cooled Motors.** On non-XSD™ motors, remove the caps on the fan cover for access to the grease plugs. Follow the greasing instructions described above for dripproof motors. XSD™ motors have automatic grease relief fittings, and the fittings extend through the fan cover. Simply pump grease into the motor until it comes out the automatic relief fitting. The extended grease pipes should be removed and cleaned occasionally during regreasing.
- e) **Motors not having pipe plugs or grease fittings** in bearing housing can be relubricated by removing endshield from motor, cleaning grease cavity and refilling with recommended grease.
Caution: Bearings and grease must be kept free of dirt.

Table 2. Motor Lubrication Guide

| Type of Service | Typical Examples | Hp Range | Lubrication Interval | |
|-----------------|--|----------|----------------------|----------|
| | | | Horizontal | Vertical |
| Easy | Infrequent use 1 hour per day Valves Door openers | .5-7.5 | 10 yrs. | 9 yrs. |
| | | 10-40 | 7 yrs. | 3 yrs. |
| | | 50-150 | 4 yrs. | 1.5 yrs. |
| | | 200-350 | 3 yrs. | 9 mos. |
| Standard | 1 or 2 shifts Machine tools Air conditioning Conveyor; Oil-wells Garage compressors Refrigeration equipment Woodworking, Laundry | .5-7.5 | 7 yrs. | 3 yrs. |
| | | 10-40 | 4 yrs. | 1 yr. |
| | | 50-150 | 1.5 yrs | 6 mos. |
| | | 200-350 | 1 yr. | 3 mos. |
| Severe | Continuous duty 24 hours per day 365 days per year Mining machinery Severe vibration | .5-7.5 | 4 yrs. | 1.5 yrs. |
| | | 10-40 | 1.5 yrs. | 6 mos. |
| | | 50-150 | 9 mos. | 3 mos. |
| | | 200-350 | 6 mos. | 1.5 mos. |
| Very Severe | Dirt and vibration High ambient End of shaft hot (pumps and fans) | .5-7.5 | 9 mos. | 6 mos. |
| | | 10-40 | 4mos. | 3 mos. |
| | | 50-150 | 4 mos. | 2 mos. |
| | | 200-350 | 3 mos. | 1 mo. |

III. Explosion-Proof Motors

- a) Explosion-proof motors have special features and are manufactured in accordance with U/L and carry its label. Therefore, it is recommended that repairs be made at a GE Service Shop which has been authorized to make such repairs.

IV. Motor Windings

- a) To clean motors use a soft brush and, if necessary, a slow acting solvent in a well ventilated room.

Service

Your GE motor should be serviced only by qualified persons who have the proper tools and equipment. Fast, dependable in-warranty service for your motor can be obtained from any of the worldwide network of GE Authorized Electric Motor Servicenters. Consult the Yellow Pages of your telephone directory for the Servicenter nearest you.

These instructions do not purport to cover all details or variations in equipment nor to provide for every possible contingency to be met in connection with installation, operation or maintenance. Should further information be desired or should particular problems arise which are not covered sufficiently for the purchaser's purposes, the matter should be referred to the General Electric Co.



GOULDS PUMPS

Installation, Operation and Maintenance Instructions

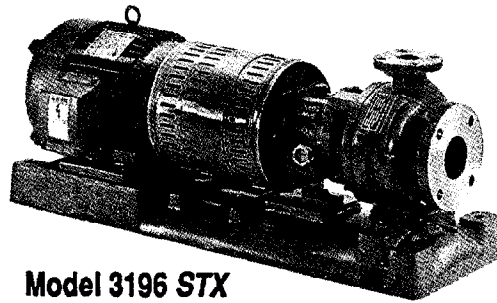

Model 3196 STX

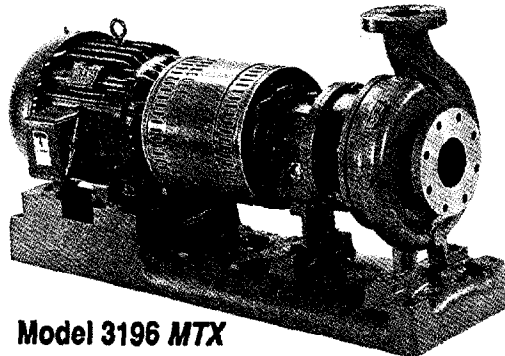

Model 3196 MTX

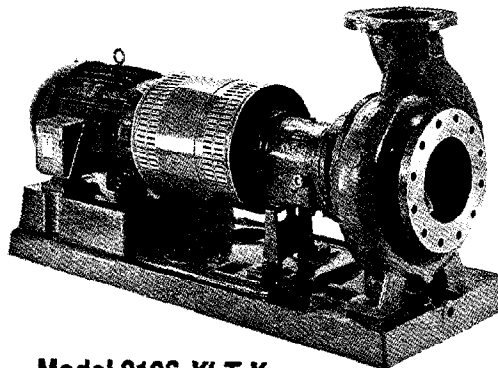

Model 3196 XLT-X

Model 3196

FOREWORD

This manual provides instructions for the Installation, Operation, and Maintenance of the Goulds Model 3196 ANSI Standard Dimension Process Pump. This manual covers the standard product plus common options that are available. For special options, supplemental instructions are supplied. **This manual must be read and understood before installation and start-up.**

The design, materials, and workmanship incorporated in the construction of Goulds pumps makes them capable of giving, trouble-free service. The life and satisfactory service of any mechanical unit, however, is enhanced and extended by correct application, proper installation, periodic inspection, condition monitoring and careful maintenance. This instruction manual was prepared to assist operators in understanding the construction and the correct methods of installing, operating, and maintaining these pumps.

Goulds shall not be liable for physical injury, damage or delays caused by a failure to observe the instructions for Installation, Operation, and Maintenance contained in this manual.

Warranty is valid only when genuine Goulds parts are used.

Use of the equipment on a service other than stated in the order will nullify the warranty, unless written approval is obtained in advance from Goulds Pumps, Inc.

Supervision by an authorized Goulds representative is recommended to assure proper installation.

Additional manuals can be obtained by contacting your local Goulds representative or by calling 1-800-446-8537.

THIS MANUAL EXPLAINS

- **Proper Installation**
- **Start-up Procedures**
- **Operation Procedures**
- **Routine Maintenance**
- **Pump Overhaul**
- **Trouble Shooting**
- **Ordering Spare or Repair Parts**

TABLE OF CONTENTS

| Page | | SECTION |
|-------------|-------------------------------------|----------------|
| 7 | SAFETY | 1 |
| 9 | GENERAL INFORMATION | 2 |
| 13 | INSTALLATION | 3 |
| 21 | OPERATION | 4 |
| 27 | PREVENTIVE MAINTENANCE | 5 |
| 35 | DISASSEMBLY & REASSEMBLY | 6 |
| 77 | SPARE AND REPAIR PARTS | 7 |
| 81 | APPENDIX | 8 |

SAFETY

| | |
|-------------------------------|---|
| DEFINITIONS | 7 |
| GENERAL PRECAUTIONS | 7 |

DEFINITIONS

This pump has been designed for safe and reliable operation when properly used and maintained in accordance with instructions contained in this manual. A pump is a pressure containing device with rotating parts that can be hazardous. Operators and maintenance personnel must realize this and follow safety measures. Goulds Pumps Inc. shall not be liable for physical injury, damage or delays caused by a failure to observe the instructions in this manual.

Throughout this manual the words **Warning**, **Caution**, and **Note** are used to indicate procedures or situations which require special operator attention:



WARNING

Warning is used to indicate the presence of a hazard which can cause severe personal injury, death, or substantial property damage if the warning is ignored.



CAUTION

Caution is used to indicate the presence of a hazard which will or can cause minor personal injury or property damage if the warning is ignored.

NOTE: Operating procedure, condition, etc. which is essential to observe.

EXAMPLES



WARNING

Pump shall never be operated without coupling guard installed correctly.



CAUTION

Throttling flow from the suction side may cause cavitation and pump damage.

NOTE: Proper alignment is essential for long pump life.

GENERAL PRECAUTIONS



WARNING

Personal injuries will result if procedures outlined in this manual are not followed.

- Never apply heat to remove impeller. It may explode due to trapped liquid.
- Never use heat to disassemble pump due to risk of explosion from trapped liquid.
- Never operate pump without coupling guard correctly installed.
- Never operate pump beyond the rated conditions to which the pump was sold.

- Never start pump without proper prime (sufficient liquid in pump casing).
- Never run pump below recommended minimum flow or when dry.
- Always lock out power to the driver before performing pump maintenance.
- Never operate pump without safety devices installed.
- Never operate pump with discharge valve closed.
- Never operate pump with suction valve closed.
- Do not change conditions of service without approval of an authorized Goulds representative.

GENERAL INFORMATION

| | |
|--|-----------|
| PUMP DESCRIPTION | 9 |
| NAMEPLATE INFORMATION | 10 |
| RECEIVING THE PUMP | 11 |
| Storage Requirements | 11 |
| Handling | 11 |

PUMP DESCRIPTION

The Model 3196 is a horizontal overhung, open impeller centrifugal pump that meets requirements of ANSI B73.1.

The model is based on 5 power ends and 28 hydraulic pump sizes. Groupings are as follows:

| | |
|-------|---------------|
| STX | 5 pump sizes |
| MTX | 15 pump sizes |
| LTX | 11 pump sizes |
| XLT-X | 5 pump sizes |
| X17 | 3 pump sizes |

Casing - The casing is top centerline discharge and self-venting. The gasket is fully confined. An integral foot support is used for maximum resistance to misalignment and distortion from piping loads. ANSI flat face serrated flanges are standard. ANSI Class 150 raised face serrated, ANSI Class 300 flat face serrated and ANSI Class 300 raised face serrated are available.

Impeller - The impeller is fully open and threaded to the shaft. The threads are sealed from the pumpage by a Teflon O-ring.

Seal Chamber/Stuffing-Box Cover - The 3196 is available with a stuffing box cover designed for packing and BigBore™ seal chamber or TaperBore™ seal chamber for improved performance of mechanical seals.

Frame Adapter - The ductile iron frame adapter has machined rabbet fit to the seal chamber/stuffing box cover and precision dowel pin fit to the bearing frame.

Power End - Oil level is viewed through a sight glass. Optional oil cooling is provided by a finned tube. Flood oil lube is standard. The power end is sealed with Goulds designed labyrinth seals. No machining is required to convert from oil to grease or oil mist. Regreaseable bearings, greased for life bearings and oil mist lubrication are optional.

Shaft - The shaft is available with or without sleeve.

Bearings - The inboard bearing carries only radial load, it is free to float axially in the frame. The outboard bearing is shouldered and locked to the shaft and housing to enable it to carry radial and thrust loads. All fits are precision machined to industry standards. The inboard bearing is a single row deep groove ball bearing. The outboard bearing is a double row angular contact bearing, except for the LTX which uses a pair of single row angular contact ball bearings mounted back to back.

Dynamic Seal - A dynamic seal is available which uses a repeller to pump liquid out of the stuffing box while the pump operates, a static seal prevents leakage when the pump is shut down.

Direction of Rotation - Clockwise (right hand) as viewed from the driver, looking at the pump shaft.

NAMEPLATE INFORMATION

GOULDS PUMPS, INC. SENECA FALLS, N.Y.
 MADE IN USA

IMPLR. DIA. MAX. DIA.
 GPM FT HD RPM
 MOD. SIZE
 STD. NO. MAT. L. CONSTR.
 SER. NO. MAX. DSGN. PSI @ 100F
CAUTION: AFTER STARTING DO NOT OPERATE AGAINST CLOSED VALVE

Fig. 1

Every pump has two Goulds nameplates that provide information about the pump. The tags are located on the casing and bearing frame.

Pump Casing Tag - provides information about the pump's hydraulic characteristics. Note the format of the pump size: Discharge x Suction - Nominal maximum Impeller Diameter in inches. (Example: 2x3-6)(Fig. 1).

Bearing Frame Tag - provides information on the lubrication system used (Fig. 2).

When ordering spare parts you will need to identify pump model, size, serial number, and the item number of required parts. Information can be taken from the pump casing tag. Item numbers can be found in this manual.

GOULDS PUMPS INC. SENECA FALLS, N.Y.
 MADE IN USA

MOD.
 SIZE
 SER. NO.
 LUBE

Fig. 2

RECEIVING THE PUMP

Inspect the pump as soon as it is received. Carefully check that everything is in good order. Make notes of damaged or missing items on the receipt and freight bill. File any claims with the transportation company as soon as possible.

STORAGE REQUIREMENTS

Short Term: (Less than 6 months) Goulds normal packaging procedure is designed to protect pump during shipping. Upon receipt store in a covered and dry location.

Long Term: (More than 6 months) Preservative treatment of bearings and machined surfaces will be required. Rotate shaft several times every 3 months. Refer to driver and coupling manufacturers for their long term storage procedures. Store in a covered dry location.

NOTE: Long term storage treatment can be purchased with initial pump order.

HANDLING



WARNING

Pump and components are heavy. Failure to properly lift and support equipment could result in serious physical injury, or damage to pumps. Steel toed shoes must be worn at all times.

Use care when moving pumps. Lifting equipment must be able to adequately support the entire assembly. Hoist bare pump using a suitable sling, under the suction flange and bearing frame. Baseplate mounted units are moved with slings under the pump casing and driver. Refer to figures 3A,B,C for examples of proper lifting techniques.

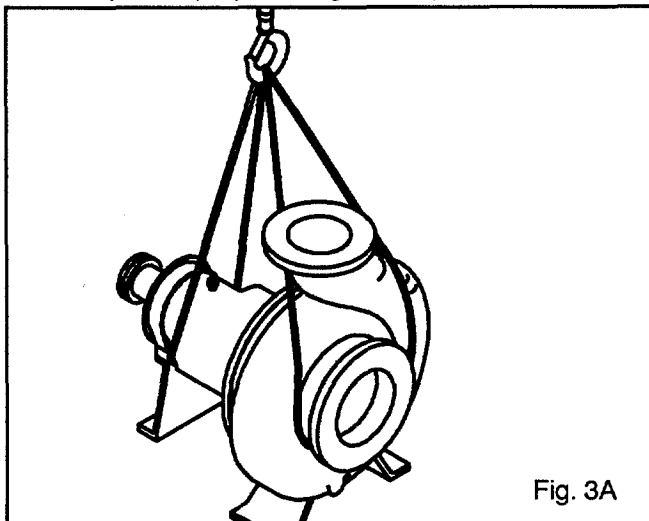

Fig. 3A

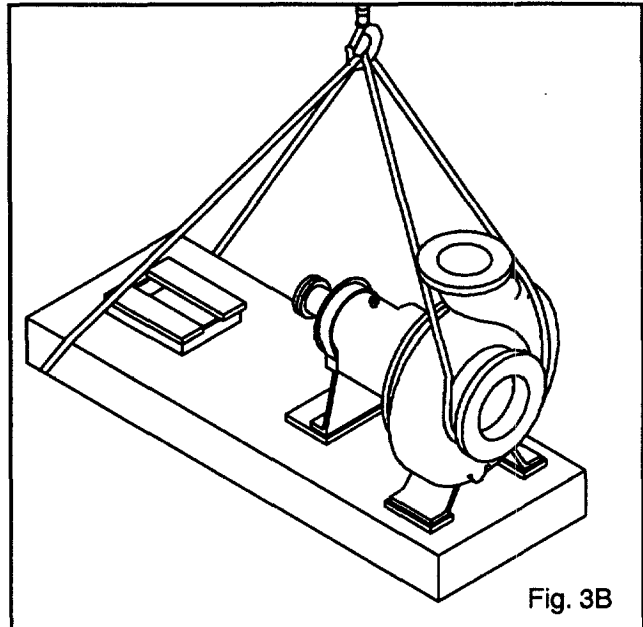

Fig. 3B

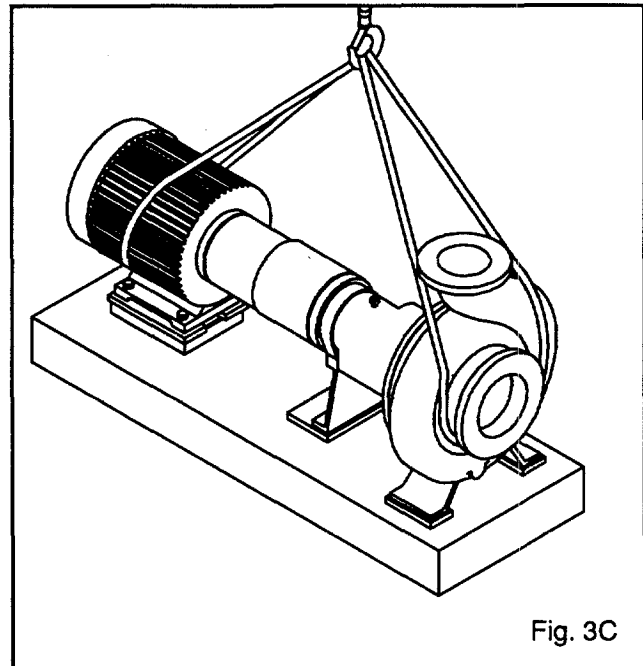

Fig. 3C

INSTALLATION

| | |
|--|----|
| SITE/FOUNDATION | 13 |
| LEVEL BASEPLATE | 14 |
| ALIGNMENT AND ALIGNMENT PROCEDURE | 14 |
| Alignment Check | 14 |
| Alignment Criteria | 15 |
| Set Up | 15 |
| Measurement | 15 |
| Angular Alignment | 16 |
| Parallel Alignment | 16 |
| Complete Alignment | 17 |
| Alignment Trouble Shooting | 17 |
| GROUT BASEPLATE | 18 |
| Alignment Check | 18 |
| PIPING | 18 |
| General | 18 |
| Suction Piping | 19 |
| Discharge Piping | 19 |
| Final Piping Check | 19 |

SITE/FOUNDATION

A pump should be located near the supply of liquid and have adequate space for operation, maintenance, and inspection.

Baseplate mounted pumps are normally grouted on a concrete foundation, which has been poured on a solid footing. The foundation must be able to absorb any vibration and to form a permanent, rigid support for the pumping unit.

The location and size of the foundation bolts are shown on outline assembly drawing, provided with the pump data package.

Foundation bolts commonly used are sleeve type (Fig. 4A) and J type (Fig. 4B). Both designs permit movement for final bolt adjustment.

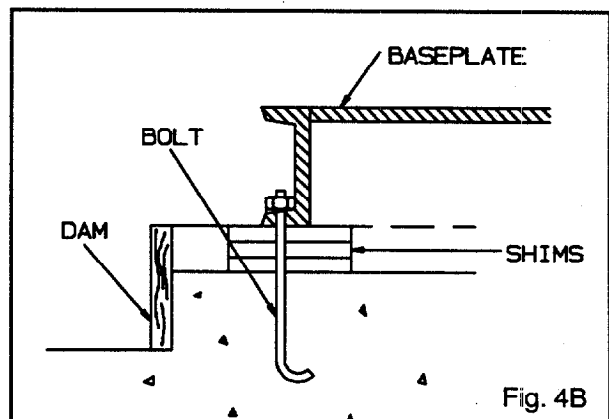
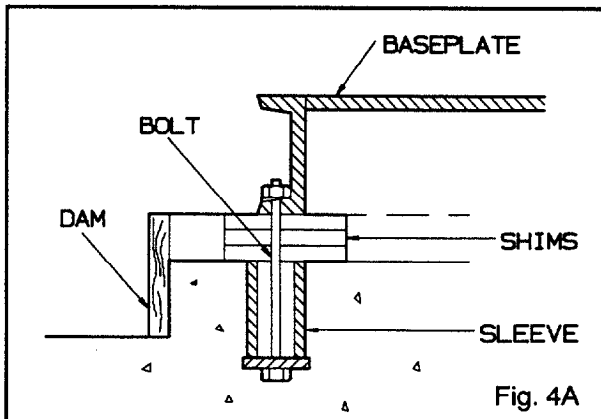

LEVEL BASEPLATE

1. Place 2 sets of wedges or shims on the foundation, one set on each side of every foundation bolt. The wedges should extend .75 in. (20mm) to 1.5 in. (40mm) above foundation, to allow for adequate grouting. This will provide even support for the baseplate once it is grouted.
2. Remove water and/or debris from anchor bolt holes/sleeves prior to grouting. If the sleeve type bolts are being used, fill the sleeves with rags to prevent grout from entering.
3. Carefully lower baseplate onto foundation bolts.
4. Level baseplate to within 1/8" (3.2mm) over length of the baseplate and to within .088 in. (1.5mm) over the width of the base by adjusting wedges.
5. Hand tighten bolts.

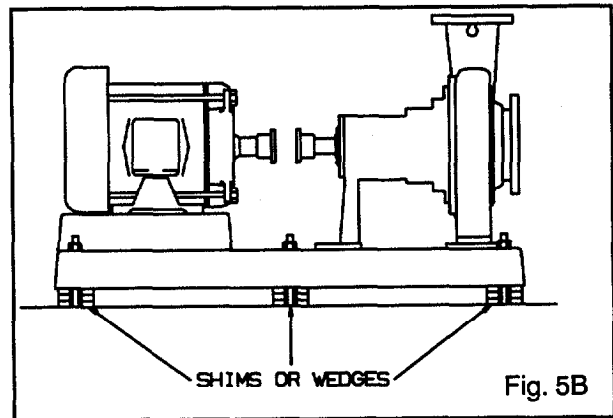
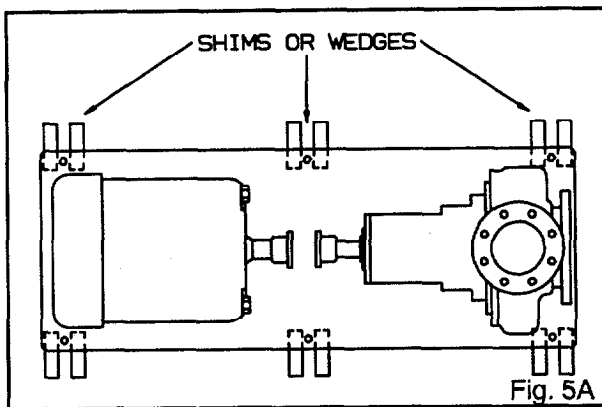

ALIGNMENT AND ALIGNMENT PROCEDURE



WARNING

Before beginning any alignment procedure make sure driver power is locked out. Failure to lock out driver power will result in serious physical injury.

To remove guard refer to coupling guard assembly/disassembly instructions.

The points at which alignment is checked and adjusted are:

- **Initial Alignment** is done prior to operation when the pump and the driver are at ambient temperature.
- **Final Alignment** is done after operation when the pump and driver are at operating temperature.

Alignment is achieved by adding or removing shims from under the feet of the driver and shifting equipment horizontally as needed.

NOTE: Proper alignment is the responsibility of the installer and user of the unit.

Accurate alignment of the equipment must be attained. Trouble free operation can be accomplished by following these procedures.

ALIGNMENT CHECKS

Initial Alignment (Cold Alignment)

- Before Grouting Baseplate - To ensure alignment can be obtained.
- After Grouting Baseplate - To ensure no changes have occurred during grouting process.
- After Connecting Piping - To ensure pipe strains haven't altered alignment. If changes have occurred, alter piping to remove pipe strains on pump flanges.

Final Alignment (Hot Alignment)

- After First Run - To obtain correct alignment when both pump and driver are at operating temperature. Thereafter, alignment should be checked periodically in accordance with plant operating procedures.

NOTE: Alignment check must be made if process temperature changes, piping changes and or pump service is performed.

ALIGNMENT CRITERIA

Good alignment is achieved when the dial indicator readings as specified in the alignment procedure are .002 in. (.05 mm) Total Indicated Reading (T.I.R.) or less when the pump and driver are at operating temperature (Final Alignment).

During the installation phase, however, it is necessary to set the parallel alignment in the vertical direction to a different criteria due to differences in expansion rates of the pump and driver. Table 1 shows recommended preliminary (cold) settings for electric motor driven pumps based on different pumpage temperatures. Driver manufacturers should be consulted for recommended cold settings for other types of drivers (steam turbines, engines, etc.)

**Table 1
Cold Setting of Parallel
Vertical Alignment**

| PUMPAGE TEMPERATURE | SET DRIVER SHAFT |
|---------------------|----------------------|
| 50°F (10°C) | .002in. (.05mm) LOW |
| 150°F (65°C) | .001in. (.03mm) HIGH |
| 250°F (120°C) | .005in. (.12mm) HIGH |
| 350°F (175°C) | .009in. (.23mm) HIGH |
| 450°F (218°C) | .013in. (.33mm) HIGH |
| 550°F (228°C) | .017in. (.43mm) HIGH |
| 650°F (343°C) | .021in. (.53mm) HIGH |
| 700°F (371°C) | .023in (.58mm) HIGH |

SET UP

1. Mount two dial indicators on one of the coupling halves (X) so they contact the other coupling half (Y) (Fig. 6).
2. Check setting of indicators by rotating coupling half X to ensure indicators stay in contact with coupling half Y but do not bottom out. Adjust indicators accordingly.

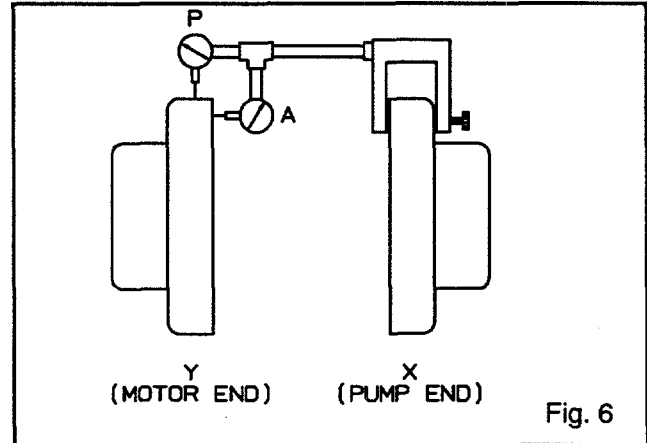

Fig. 6

3

MEASUREMENT

1. To ensure accuracy of indicator readings, always rotate both coupling halves together so indicators contact the same point on coupling half Y. This will eliminate any measurement problems due to runout on coupling half Y.
2. Take indicator measurements with driver feet hold-down bolts tightened. Loosen hold down bolts prior to making alignment corrections.
3. Take care not to damage indicators when moving driver during alignment corrections.

ANGULAR ALIGNMENT

A unit is in angular alignment when indicator A (Angular indicator) does not vary by more than .002 in. (.05 mm) as measured at four points 90° apart.

Vertical Correction (Top-to-Bottom)

1. Zero indicator A at top dead center (12 o'clock) of coupling half Y.
2. Rotate indicators to bottom dead center (6 o'clock). Observe needle and record reading.
3. **Negative Reading** - The coupling halves are further apart at the bottom than at the top. Correct by either raising the driver feet at the shaft end (add shims) or lowering the driver feet at the other end (remove shims), (Fig. 7A).

Positive Reading - The coupling halves are closer at the bottom than at the top. Correct by either lowering the driver feet at the shaft end (remove shims) or raising the driver feet at the other end (add shims).

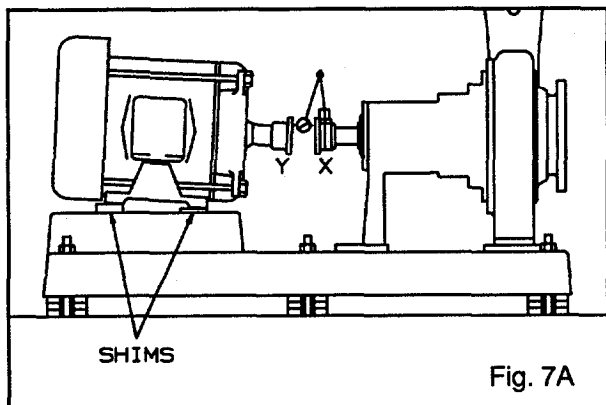

4. Repeat steps 1-3 until indicator A reads .002 in (.05 mm) or less.

Horizontal Correction (Side-to-Side)

1. Zero indicator A on left side of coupling half Y, 90° from top dead center (9 o'clock).
2. Rotate indicators through top dead center to the right side, 180° from the start (3 o'clock). Observe needle and record reading.
3. **Negative Reading** - The coupling halves are further apart on the right side than the left. Correct by either sliding the shaft end of the driver to the left or the other end to the right.

Positive Reading - The coupling halves are closer together on the right side than the left. Correct by either sliding the shaft end of the driver to the right or the other end to the left (Fig. 7B).

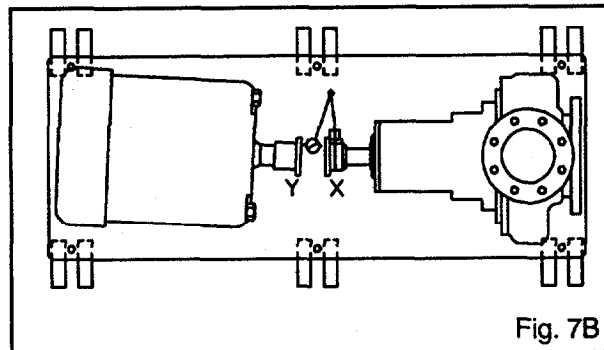

4. Repeat steps 1 through 3 until indicator A reads .002 in. (.05 mm) or less.
5. Re-check both horizontal and vertical readings to ensure adjustment of one did not disturb the other. Correct as necessary.

PARALLEL ALIGNMENT

A unit is in parallel alignment when indicator P (parallel indicator) does not vary by more than .002 in. (.05 mm) as measured at four points 90° apart at operating temperature. Note the preliminary vertical cold setting criteria, Table 1.

Vertical Correction (Top-to-Bottom)

1. Zero indicator P at top dead center of coupling (12 o'clock) half Y (Fig. 6).
2. Rotate indicator to bottom dead center (6 o'clock). Observe needle and record reading.
3. **Negative Reading** - Coupling half X is lower than coupling half Y. Correct by removing shims of thickness equal to half of the indicator reading under each driver foot.

Positive Reading - Coupling half X is higher than coupling half Y. Correct by adding shims of thickness equal to half of the indicator reading from each driver foot (Fig. 8A).

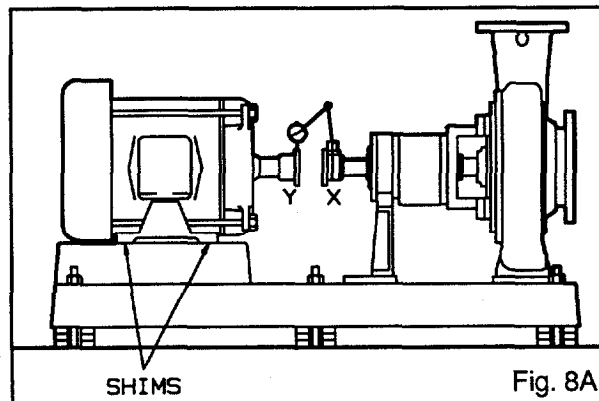

NOTE: Equal amounts of shims must be added to or removed from each driver foot. Otherwise the vertical angular alignment will be affected.

- Repeat steps 1 through 3 until indicator P reads within .002 in. (.05 mm) or less when hot, or per Table 1 when cold.

Horizontal Correction (Side-to-Side)

- Zero indicator P on the left side of coupling half Y, 90° from top dead center (9 o'clock).
- Rotate indicators through top dead center to the right side, 180° from the start (3 o'clock). Observe needle and record reading.
- Negative Reading** - Coupling half Y is to the left of coupling half X. Correct by sliding driver evenly in the appropriate direction (Fig. 8B).

Positive Reading - Coupling half Y is to the right of coupling half X. Correct by sliding driver evenly in the appropriate direction.

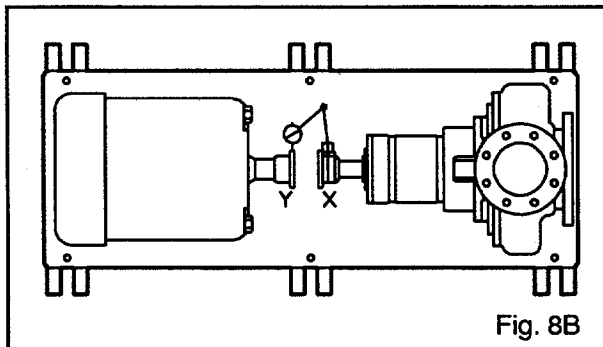

Fig. 8B

NOTE: Failure to slide motor evenly will affect horizontal angular correction.

- Repeat steps 1 through 3 until indicator P reads .002 in. (.05 mm) or less.
- Re-check both horizontal and vertical readings to ensure adjustment of one did not disturb the other. Correct as necessary.

COMPLETE ALIGNMENT

A unit is in complete alignment when both indicators A (angular) and P (parallel) do not vary by more than .002 in. (.05 mm) as measured at four points 90° apart.

Vertical Correction (Top-to-Bottom)

- Zero indicators A and P at top dead center (12 o'clock) of coupling half Y.
- Rotate indicator to bottom dead center (6 o'clock). Observe the needles and record the readings.
- Make corrections as outlined previously.

Horizontal Correction (Side-to-Side)

- Zero indicators A and P on the left side of coupling half Y, 90° from top dead center (9 o'clock).
- Rotate indicators through top dead center to the right side, 180° from the start (3 o'clock). Observe the needle, measure and record the reading.
- Make corrections as outlined previously.
- Recheck both vertical and horizontal readings to ensure adjustment of one did not disturb the other. Correct as necessary.

NOTE: With experience, the installer will understand the interaction between angular and parallel and will make corrections appropriately.

3

**Table 2
Alignment Trouble Shooting**

| PROBLEM | PROBABLE CAUSE | REMEDY |
|--|---|---|
| Cannot obtain horizontal (Side-to-Side) alignment, angular or parallel | Driver feet bolt bound. | Loosen pump hold down bolts and slide pump and driver until horizontal alignment is achieved. |
| | Baseplate not leveled properly, probably twisted. | Determine which corner(s) of the baseplate are high or low and remove or add shims at the appropriate corner(s) and realign. |
| Cannot obtain vertical (Top-to-Bottom) alignment, angular or parallel | Baseplate not leveled properly, probably bowed. | Determine if center of baseplate should be raised or lowered and correct by evenly adding or removing shims at the center of the baseplate. |

GROUT BASEPLATE

1. Clean areas of baseplate that will contact grout. Do not use oil-based cleaners because grout will not bond to it. Refer to grout manufacturer's instructions.
2. Build dam around foundation. Thoroughly wet foundation (Fig. 9A).
3. Pour grout through grout hole in baseplate, up to level of dam. Remove air bubbles from grout as it is poured by puddling, using a vibrator, or pumping the grout into place. Non-shrink grout is recommended.
4. Allow grout to set.
5. Fill remainder of baseplate with grout. Remove air as before (Fig. 9B).

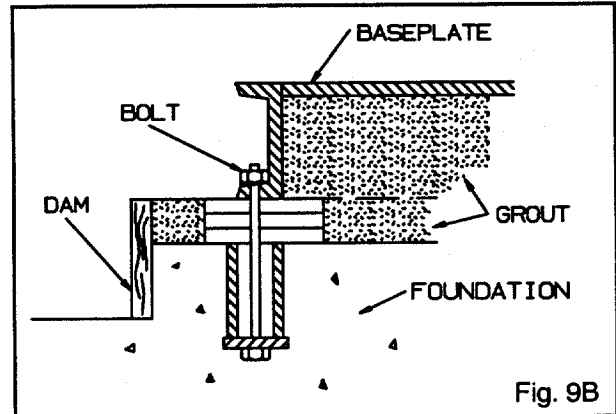
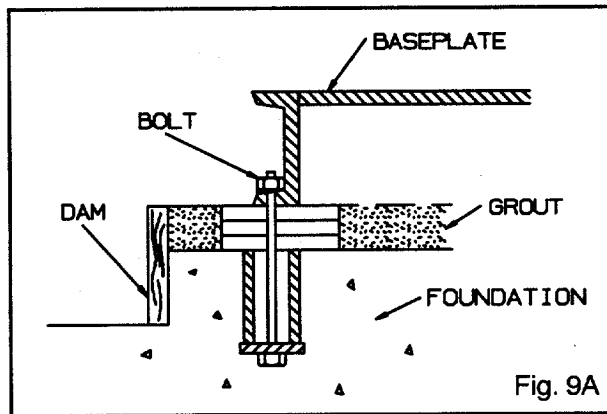

6. Allow grout to set at least 48 hours.
7. Tighten foundation bolts.

ALIGNMENT CHECK

Re-check alignment before continuing, using methods previously described.

PIPING

GENERAL

Guidelines for piping are given in the "Hydraulic Institute Standards" available from: Hydraulic Institute, 30200 Detroit Road, Cleveland, OH 44145-1967 and must be reviewed prior to pump installation.



WARNING

Never draw piping into place by forcing at the flanged connections of the pump. This may impose dangerous strains on the unit and cause misalignment between pump and driver. Pipe strain will adversely effect the operation of the pump resulting in physical injury and damage to the equipment.

1. All piping must be supported independently of, and line up naturally with, the pump flanges.
2. Piping runs should be as short as possible to minimize friction losses.
3. DO NOT connect piping to pump until grout has hardened and pump and driver hold-down bolts have been tightened.
4. It is suggested that expansion loops or joints be properly installed in suction and/or discharge lines when handling liquids at elevated temperatures, so linear expansion of piping will not draw pump out of alignment.
5. The piping should be arranged to allow pump flushing prior to removal of the unit on services handling corrosive liquids.
6. Carefully clean all pipe parts, valves and fittings, and pump branches prior to assembly.

SUCTION PIPING



WARNING

NPSH_A must always exceed NPSH_R as shown on Goulds performance curves received with order. (Reference Hydraulic Institute for NPSH and pipe friction values needed to evaluate suction piping.)

Properly installed suction piping is a necessity for trouble-free pump operation. Suction piping should be flushed BEFORE connection to the pump.

1. Use of elbows close to the pump suction flange should be avoided. There should be a minimum of 2 pipe diameters of straight pipe between the elbow and suction inlet. Where used, elbows should be long radius.
2. Use suction pipe one or two sizes larger than the pump suction, with a reducer at the suction flange. Suction piping should never be of smaller diameter than the pump suction.
3. Reducers, if used, should be eccentric, at the pump suction flange, with sloping side down.
4. Pump must never be throttled on suction side.
5. Suction strainers, when used, must have a net "free area" of at least three times the suction pipe area.
6. Separate suction lines are recommended when more than one pump is operating from the same source of supply.

Suction lift conditions

1. Suction pipe must be free from air pockets.
2. Suction piping must slope upwards to pump.
3. All joints must be air tight.
4. A means of priming the pump must be provided, such as a foot valve.

Suction head/Flooded suction conditions

1. An isolation valve should be installed in the suction line at least two pipe diameters from the suction to permit closing of the line for pump inspection and maintenance.
2. Keep suction pipe free from air pockets.
3. Piping should be level or slope gradually downward from the source of supply.
4. No portion of the piping should extend below pump suction flange.

5. The size of entrance from supply should be one or two sizes larger than the suction pipe.
6. The suction pipe must be adequately submerged below the liquid surface to prevent vortices and air entrainment at the supply.

DISCHARGE PIPING

1. Isolation and check valves should be installed in discharge line. Locate the check valve between isolation valve and pump, this will permit inspection of the check valve. The isolation valve is required for priming, regulation of flow, and for inspection and maintenance of pump. The check valve prevents pump or seal damage due to reverse flow through the pump when the driver is turned off.
2. Increasesers, if used, should be placed between pump and check valves.
3. Cushioning devices should be used to protect the pump from surges and water hammer if quick-closing valves are installed in system.

FINAL PIPING CHECK

After connecting the piping to pump:

1. Rotate shaft several times by hand to be sure that there is no binding and all parts are free.
2. Check alignment, per the alignment procedure outlined previously to determine absence of pipe strain. If pipe strain exists, correct piping.

OPERATION

| | |
|---|-----------|
| PREPARATION FOR START-UP | 21 |
| Checking Rotation | 21 |
| Check Impeller Clearance | 21 |
| Couple Pump and Driver | 22 |
| Lubricating Bearings | 22 |
| Shaft Sealing | 22 |
| Priming Pump | 24 |
| STARTING PUMP | 25 |
| OPERATION | 26 |
| General Considerations | 26 |
| Operating at Reduced Capacity | 26 |
| Operating under Freezing Conditions | 26 |
| SHUTDOWN | 26 |
| FINAL ALIGNMENT | 26 |

PREPARATION FOR START-UP

CHECKING ROTATING

CAUTION

Serious damage may result if pump is run in the wrong rotation.

1. Lock out power to driver.

WARNING

Lock out driver power to prevent accidental start-up and physical injury.

2. Make sure coupling hubs are securely fastened to shafts.

NOTE: Pump is shipped with coupling spacer removed.

3. Unlock driver power.
4. Make sure everyone is clear. Jog driver just long enough to determine direction of rotation. Rotation must correspond to arrow on bearing housing.
5. Lock out power to driver.

CHECK IMPELLER CLEARANCE

Prior to starting the pump the impeller clearance must be checked. The pump efficiency is maintained when the proper impeller clearance is set. The optimum hydraulic performance is attained by setting the impeller front clearance at the factory to predetermined limits which are consistent with service conditions.

| Frame Designation | Impeller Front Clearance Inch (mm) |
|-------------------|------------------------------------|
| STX | .005 (.13) |
| MTX, LTX | .008 (.20) |
| XLTX, X17 | .015 (.38) |

The maximum impeller setting should not be set more than .005 inch (0.13mm) above values in table or significant performance degradation will result.

Also, for pumpage temperatures above 200 degrees F (93 degrees C) the cold (ambient) setting must be increased per Table 3. This is necessary to prevent the impeller from contacting the casing due to differential expansion from the higher operating temperatures. See Preventative Maintenance section for impeller adjustment procedure.

| Table 3 | | | |
|---|---------------|---------------|---------------|
| Impeller Clearances | | | |
| COLD TEMPERATURE CLEARANCES FOR VARIOUS SERVICE TEMPERATURES | | | |
| Service Temperature | STX | MTX/LTX | XLTX/X17 |
| Up to 200°F (93°C) | .005" (.13mm) | .008" (.20mm) | .015" (.38mm) |
| 200 to 250°F (121°C) | .007" (.18mm) | .010" (.26mm) | .017" (.43mm) |
| 250°F to 300°F (149°C) | .009" (.23mm) | .012" (.30mm) | .019" (.48mm) |
| 300°F to 350°F (177°C) | .011" (.28mm) | .014" (.36mm) | .021" (.53mm) |
| 350°F to 400°F (204°C) | .013" (.33mm) | .016" (.41mm) | .023" (.58mm) |
| Over 400°F (204°C) | .015" (.38mm) | .018" (.46mm) | .025" (.64mm) |

COUPLE PUMP AND DRIVER



WARNING

Lock out driver power to prevent accidental rotation and physical injury.

1. Install and lubricate coupling per manufacturer's instructions.
2. Install coupling guard (Fig. 12). Refer to Coupling Guard Installation and Disassembly Section (Appendix II).



WARNING

Never operate a pump without coupling guard properly installed. Refer to Appendix II for coupling guard installation instructions. Personal injury will occur if pump is run without coupling guard.

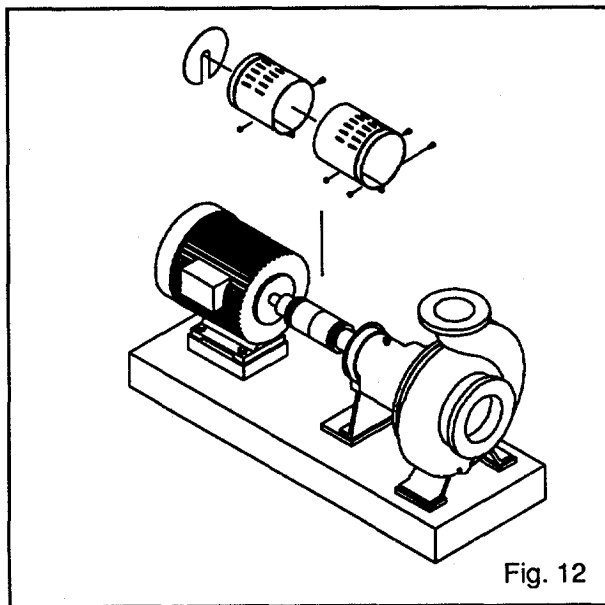

Fig. 12

LUBRICATING BEARINGS



CAUTION

Pumps are shipped without oil.

Oil Lubrication: Fill bearing frame with oil, through filler connection (located on top of bearing frame refer to Fig. 18B), until oil level reaches the middle of the sight-glass. A high quality turbine type oil, with rust and oxidation inhibitors should be used.

Pure Oil Mist Lubrication: Oil mist is an optional feature for the 3196. Follow oil mist generator manufacturer's instructions. The inlet connections are located on the top of the bearing frame, connection points are covered under lubrication. (Refer to Appendix I on converting lubrication).

Grease Lubrication: Pumps are shipped with grease. See Table 6.

Greased For Life Bearings: These bearings are filled with grease and sealed by the bearing manufacturer.

If pump is put into operation after prolonged shut-down, flush out bearings and bearing frame with a light oil to remove contaminants. During flushing rotate shaft slowly by hand. Finally, flush bearing housing with proper lubricating oil to insure oil quality after cleaning.

See Preventive Maintenance section for lubrication recommendations.



WARNING

Operation of the unit without proper lubrication will cause bearing failure, and pump seizure.

SHAFT SEALING

Mechanical Seal Option: Pumps may be shipped with or without mechanical seals installed. A common seal with this model is the cartridge type. Cartridge seals are preset at the seal manufacturer's facility and require no field settings. Cartridge Seals installed by the user require removal of the holding clips prior to operation, allowing the seal to slide into place. If the seal has been installed in the pump at the Goulds factory, these clips have already been removed. For other types of mechanical seals, refer to the seal manufacturer's instructions for installation and setting.

Connection of Sealing Liquid: For satisfactory operation, there must be a liquid film between seal faces to lubricate them. Refer to seal manufacturer's drawing for location of taps. Some methods which may be used to flush/cool the seal are:

- a. **Product Flushing** - In this arrangement, the pumpage is piped from the casing (and cooled in an external heat exchanger when required) then injected into seal gland.
- b. **External Flush** - A clean, cool compatible liquid is injected from an outside source directly into seal gland. Flushing liquid must be at a pressure 5-15 PSI (0.35-1.01 kg/cm²) greater than the stuffing box/seal chamber pressure. Injection rate should be 1/2-2 GPM (2-8 LPM).

- c. Other methods may be used which make use of multiple gland connections and/or stuffing box connections. Refer to documentation supplied with the pump, mechanical seal reference drawing, and piping diagrams.

Packed Stuffing Box Option: Pumps are shipped without packing, lantern ring or split gland installed. These are included with the box of fittings shipped with the pump and must be installed before start-up.

Installation of packing:

1. Carefully clean stuffing box bore.
2. Twist the packing just enough to get it around the shaft (Fig. 13A,B).
3. Insert packing, staggering the joints in each ring by 90°.
4. The stuffing box arrangement in order of installation is: 2 packing rings, lantern ring (one piece), then 3 packing rings.

CAUTION
 Follow instructions to insure the lantern ring is located at the flushing connection Fig. 14. Otherwise no flush will be obtained.

5. Install the gland halves and evenly hand tighten the nuts.

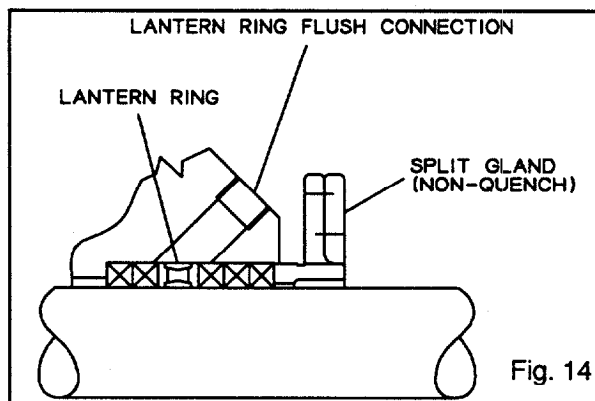
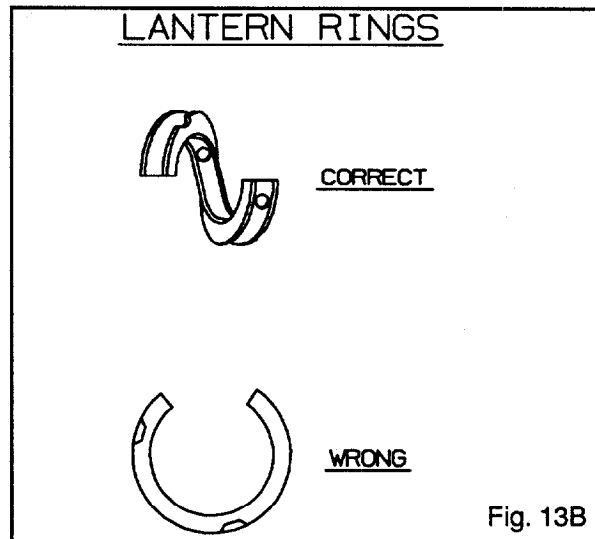
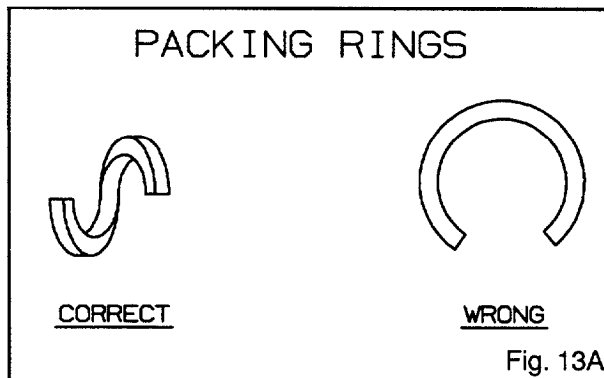

Connection of Sealing Liquid: If stuffing box pressure is above atmospheric pressure and pumpage is clean, normal gland leakage of 40-60 drops per minute is usually sufficient to lubricate and cool packing and sealing liquid is not required.

NOTE: Otherwise a product flush can be used if a clean pumpage exists.

An external sealing liquid is required when:

1. Abrasive particles in pumpage could score shaft sleeve.
2. Stuffing box pressure is below atmospheric pressure due to pump running with suction lift, or when suction source is under vacuum. Under these conditions, packing will not be cooled and lubricated and air will be drawn into pump.

If an outside source of clean compatible liquid is required, the pressure should be 15 PSI (1.0 kg/cm²) above suction pressure. The piping should be connected to the lantern ring connection.

NOTE: Most packing requires lubrication. Failure to lubricate packing may shorten the life of the packing and pump.

Dynamic Seal Option: The dynamic seal consists of two seals: a repeller that prevents leakage during pump operation and a secondary seal that prevents leakage when the unit is off. The repeller acts as a pump to prevent liquid from entering the stuffing box during pump operation. The repeller does not require a flush except for services which allow a build-up of solids on the repeller. A flush hole can be provided for this purpose. A drain hole can also be supplied to drain repeller chamber if danger of freezing exists.

Secondary Seals: The secondary seal prevents leakage during pump shut down. This seal is either graphite packing or an elastomeric face or lip seal.

1. **Graphite packing** - This packing will provide adequate life running dry but will provide longer performance if it is lubricated with either clean water or grease. When clean water is used, remember that the repeller reduces both the quantity and pressure of seal water required. If the suction head is less than the repeller capability, the stuffing box pressure is the same as atmospheric. Seal water pressure must be high enough to overcome static head when the pump is not operating to keep pumpage out of the packing. Flow must be sufficient to cool the packing. If grease is used as the lubricant, spring-loaded grease lubricators should be used to maintain a constant supply.
2. **Elastomeric Face or Lip seal** - The elastomeric face seal consists of an elastomer rotary fitted to the shaft, and a ceramic stationary seat fitted in the gland. To set the seal, remove the gland nuts and slide the gland back on the sleeve. Pull the rotary back on the sleeve until it is about 1 inch beyond the stuffing box face. Push the gland back onto the studs, pushing the rotary back along the sleeve. Tighten the gland nuts. This ensures contact, no other adjustments are needed. The lip seal is pressed into the gland and no adjustment is required. Both seals are designed to run dry, so no flush is required.

PRIMING PUMP

Never start the pump until it has been properly primed. Several different methods of priming can be used, depending upon type of installation and service involved.

Suction Supply Above Pump:

1. Slowly open the suction valve (Fig. 15).
2. Open air vents on the suction and discharge piping until water flows out.
3. Close the vent valves.

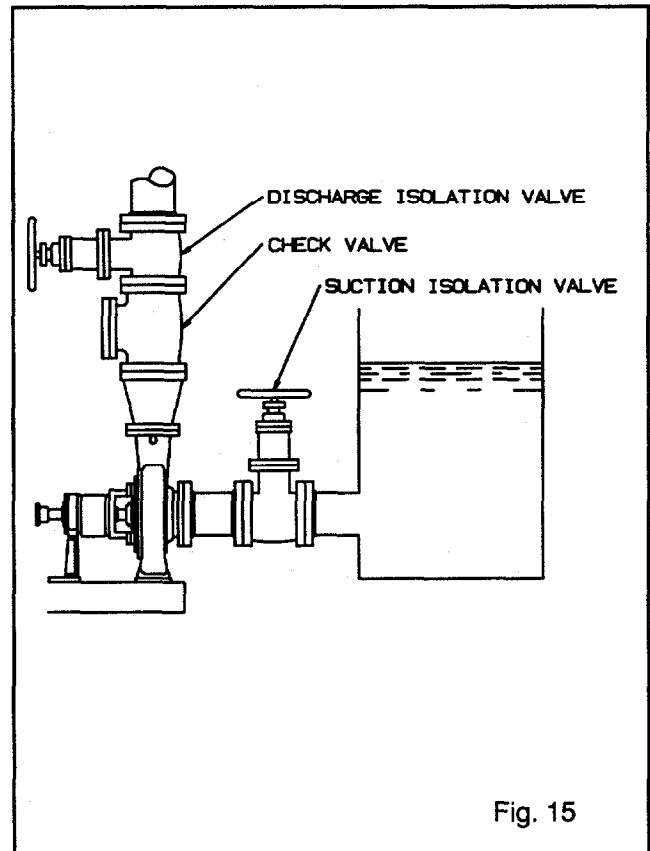

Suction supply below pump: A foot valve and outside source of liquid may be used to prime the pump. Outside source of liquid can come from a priming pump, pressurized discharge line, or other outside supply (Fig. 16 and 17).

1. Close discharge valve and open air vents in casing.
2. Open valve in outside supply line until only water escapes from vent valves.
3. Close the vent valves and then the outside supply line.

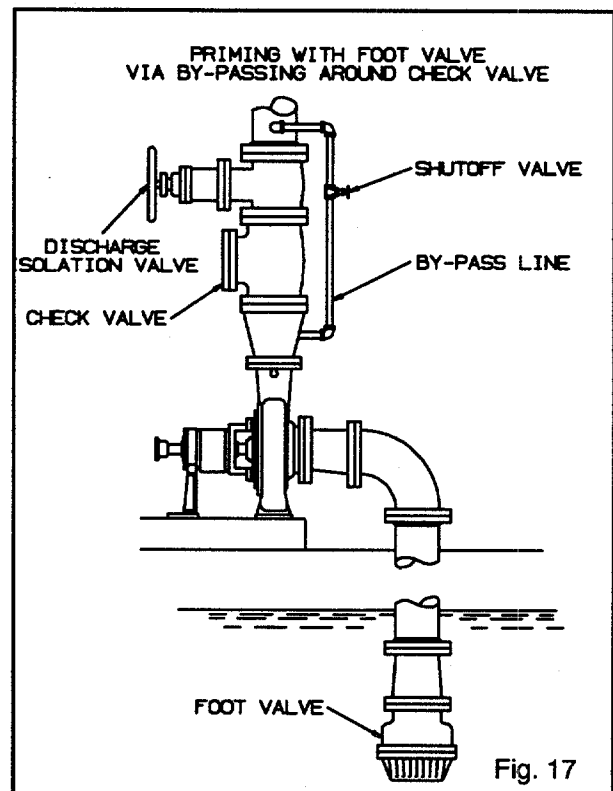
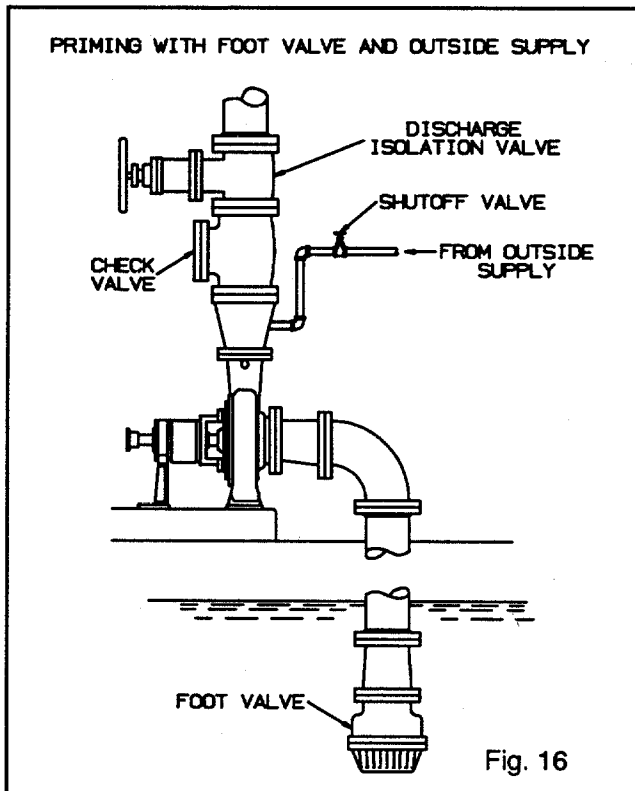

4

Other Methods of Priming:

1. Priming by Ejector.
2. Priming by Automatic Priming Pump.

STARTING PUMP

1. Make sure suction valve and any recirculation or cooling lines are open.
2. Fully close or partially open discharge valve as dictated by system conditions.
3. Start Driver.

4. Slowly open discharge valve until the desired flow is obtained.

CAUTION

Immediately observe pressure gauges. If discharge pressure is not quickly attained - stop driver, reprime and attempt to restart.

CAUTION

Observe pump for vibration levels, bearing temperature and excessive noise. If normal levels are exceeded, shut down and resolve.

OPERATION

GENERAL CONSIDERATIONS

Always vary capacity with regulating valve in the discharge line. **NEVER** throttle flow from the suction side.

Driver may overload if the pumpage specific gravity (density) is greater than originally assumed, or the rated flow rate is exceeded.

Always operate the pump at or near the rated conditions to prevent damage resulting from cavitation or recirculation.

Damage occurs from:

1. Increased vibration levels - Affects bearings, stuffing box (or seal chamber), and mechanical seal.
2. Increased radial thrusts - Stresses on shaft and bearings.
3. Heat build up - Vaporization causing rotating parts to score or seize.
4. Cavitation - Damage to internal surfaces of pump.

OPERATING UNDER FREEZING CONDITIONS

Exposure to freezing conditions, while pump is idle, could cause liquid to freeze and damage the pump. Liquid inside pump should be drained. Liquid inside cooling coils, if supplied, should also be drained.

OPERATING AT REDUCED CAPACITY



WARNING

DO NOT operate pump below minimum rated flows or with suction and/or discharge valve closed. These conditions may create an explosive hazard due to vaporization of pumpage and can quickly lead to pump failure and physical injury. Reference Appendix III.

SHUTDOWN

1. Slowly close discharge valve.
2. Shut down and lock driver to prevent accidental rotation.



WARNING

When handling hazardous and/or toxic fluids, proper personal protective equipment should be worn. If pump is being drained, precautions must be taken to prevent physical injury. Pumpage must be handled and disposed of in conformance with applicable environmental regulation.

FINAL ALIGNMENT

1. Run the unit under actual operating conditions for a sufficient length of time to bring the pump and driver up to operating temperature.
2. Check alignment while unit is still hot per alignment procedure in Section 3.
3. Reinstall coupling guard. Refer to coupling guard instruction in Appendix II.

PREVENTIVE MAINTENANCE

| | |
|---|-----------|
| GENERAL COMMENTS | 27 |
| MAINTENANCE SCHEDULE | 27 |
| MAINTENANCE OF BEARINGS | 28 |
| Oil Lubricated Bearings | 28 |
| Grease Lubricated Bearings | 29 |
| MAINTENANCE OF SHAFT SEALS | 30 |
| Mechanical Seals | 30 |
| Packed Stuffing Box | 30 |
| Dynamic Seal | 30 |
| IMPELLER CLEARANCE SETTING | 31 |
| Dial Indicator Method | 31 |
| Feeler Gauge Method | 32 |
| TROUBLE SHOOTING | 33 |

GENERAL COMMENTS

5

A routine maintenance program can extend the life of your pump. Well maintained equipment will last longer and require fewer repairs. You should keep maintenance records, this will help pinpoint potential causes of problems.

MAINTENANCE SCHEDULE

Routine Maintenance

- Bearing lubrication
- Seal Monitoring
- Vibration analysis
- Discharge pressure
- Temperature monitoring

Routine Inspections

- Check level and condition of oil through sight glass on bearing frame.

- Check for unusual noise, vibration and bearing temperatures.
- Inspect pump and piping for leaks.
- Check seal chamber/stuffing box leakage.
 - Mechanical Seal: Should be no leakage.
 - Packing: Excessive leakage requires adjustment or possible packing replacement. Refer to Section 4: Operation for packing gland adjustment.

3 Month Inspections

- Check foundation and hold-down bolts for tightness.
- If pump has been left idle, check packing. Replace if required.
- Oil should be changed at least every 3 months (2000 hours) or more often if there are any adverse atmospheric conditions or other conditions which might contaminate or break down the oil, or if it is cloudy or contaminated as seen by inspection through the sight glass.

- Check shaft alignment and realign if required.

Annual Inspections

- Check pump capacity, pressure and power. If pump performance does not satisfy your process requirements, and process requirements have not changed, pump should be disassembled, inspected, and worn parts should be replaced, otherwise, a system inspection should be done.

MAINTENANCE OF BEARINGS

OIL LUBRICATED BEARINGS

⚠ WARNING
Pumps are shipped without oil. Oil lubricated bearings must be lubricated at the job site.

Remove fill plug (408H) and add oil until level is at the center of the sight glass (319). Replace fill plug (Fig. 18A). See Table 4.

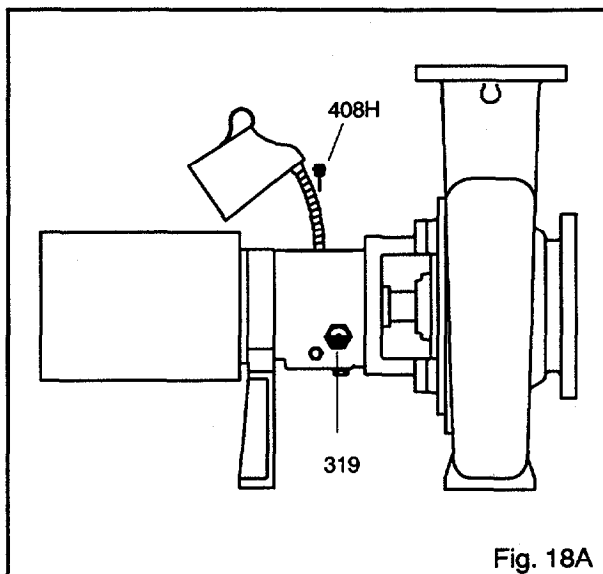

Fig. 18A

Change the oil after 200 hours for new bearings, thereafter every 2000 operating hours or 3 months (whichever comes first).

Table 4 Oil Volumes

| Frame | Pints | ml |
|---------------|-------|------|
| STX | 1.0 | 400 |
| MTX | 2.6 | 1250 |
| LTX | 3.0 | 1400 |
| XLT-X and X17 | 6.0 | 3000 |

A high quality turbine oil with rust and oxidation inhibitors should be used. For the majority of operational conditions, bearing temperatures will run between 120°F (50°C) and 180°F (82°C). In this range, an oil of ISO viscosity grade 68 at 100°F (40°C) is recommended. If bearing temperatures exceed 180°F (82°C) use ISO viscosity grade 100 with Bearing Frame cooling. See Table 5. For higher operating temperatures, pumpage above 350°F (177°C), synthetic lubrication is recommended.

Table 5 Lubricating Oil Requirements

| | Pumpage temperature below 350°F (177°C) | Pumpage temperature above 350°F (177°C) |
|---|---|---|
| ISO Grade | VG 68 | VG 100 |
| Approx. SSU at 100°F (38°C) | 300 | 470 |
| DIN 51517 | C68 | C100 |
| Kinem. viscosity at 100°F (40°C) mm ² /sec | 68 | 100 |

Some acceptable lubricants are:

- Exxon Teresstic EP 68
- Mobil Mobil DTE 26 300 SSU
 @ 100°F (38°C)
- Sunoco Sunvis 968
- Royal Purple SYNFILM ISO VG 68
 Synthetic Lube

GREASE LUBRICATED BEARINGS

Grease lubricated bearings are pre-lubricated at the factory. Regrease bearings every 2000 operating hours or 3 months.

Regrease Procedure:

NOTE: When regreasing there is danger of impurities entering the bearing housing. The grease container, the greasing device, and fittings, must be clean.

1. Wipe dirt from grease fittings.
2. Remove 2 grease relief plugs (408H) from bottom of frame.
3. Fill both grease cavities through fittings with recommended grease until fresh grease comes out of the relief holes. Reinstall grease relief plugs (408H).
4. Ensure frame seals are seated in bearing housing and if not press in place with drains located at the bottom .

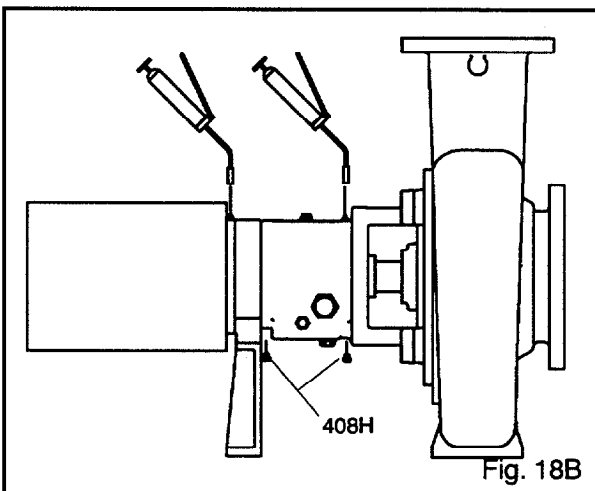

NOTE: The bearing temperature usually rises after regreasing due to an excess supply of grease. Temperatures will return to normal after pump has run and purged the excess from the bearings, usually two to four hours.

For most operating conditions a lithium based mineral oil grease of NLGI consistency No. 2 is recommended. This grease is acceptable for bearing temperatures of 5°F to 230°F (-15°C to 110°C). Bearing temperatures are generally about 20°F (18°C) higher than bearing housing outer surface temperature.

**Table 6
Lubricating Grease
Requirements**

| | Pumpage temperature below 350°F (177°C) | Pumpage temperature above 350°F (177°C) |
|------------------|---|---|
| NLGI consistency | 2 | 3 |
| Mobil | Mobilux EP2 | |
| Exxon | Unirex N2 | Unirex N3 |
| Sunoco | Multipurpose EP, | |
| SKF | LGMT 2 | LGMT 3 |

5

CAUTION
Never mix greases of different consistency (NLGI 1 or 3 with NLGI 2) or different thickener. For example never mix a lithium base grease with a polyurea base grease.

Pumpage temperatures above 350°F (177°C) should be lubricated by a high temperature grease. Mineral oil greases should have oxidation stabilizers and a consistency of NLGI 3.

NOTE: If it is necessary to change grease type or consistency, the bearings must be removed and the old grease removed.

MAINTENANCE OF SHAFT SEALS

MECHANICAL SEALS

When mechanical seals are furnished, a manufacturer's reference drawing is supplied with the data package. This drawing should be kept for future use when performing maintenance and adjusting the seal. The seal drawing will also specify required flush liquid and attachment points. The seal and all flush piping must be checked and installed as needed prior to starting the pump.

The life of a mechanical seal depends on various factors such as cleanliness of the liquid handled and its lubricating properties. Due to the diversity of operating conditions it is, however, not possible to give definite indications as to its life.



WARNING

Never operate the pump without liquid supplied to mechanical seal. Running a mechanical seal dry, even for a few seconds, can cause seal damage and must be avoided. Physical injury can occur if mechanical seal fails.

PACKED STUFFING BOX



WARNING

Lock out driver power to prevent accidental start-up and physical injury.

The stuffing box is not packed at the factory and must be packed properly before operation of the pump. The packing is furnished in a box of fittings which accompany the pump. The packing used must be suitable for the pumpage. Make sure the stuffing box is clean. Examine shaft-sleeve for wear or scoring, replace if necessary.

Starting from the innermost ring, the packing is usually arranged as two packing rings, lantern ring, three packing rings, followed by the split gland (Fig. 14). Insert single packing rings by twisting as shown in Fig. 6. Press each ring to ensure proper compression in the stuffing box. Stagger joints 90°. Refer to Fig. 13A, 13B.

Lightly and evenly tighten the gland. Excessive tightening will result in premature failure of the packing and shaft sleeve. After packing it must be possible to rotate shaft by hand. Final adjustment of packing gland is made after pump is started.

DYNAMIC SEAL

Dynamic Seal Components

Repeller - The dynamic repeller effectively prevents leakage of pumpage through the stuffing box when the pump is operating under published acceptable conditions. Dynamic seal parts do not wear substantially to affect operation unless the service is particularly abrasive or corrosive. Refer to Section 6 for maintenance disassembly and repair.

A static seal is used to prevent leakage when the pump is shut down. This is either a lip seal, elastomeric face seal, or graphite packing. The lip and elastomeric face seal require no maintenance other than replacement when leakage becomes excessive. The packing should be installed as for stuffing box packing, and is a special type designed to run dry, so does not require an external flush.

IMPELLER CLEARANCE SETTING



WARNING

Lock out driver power to prevent accidental startup and physical injury.

A change in pump performance may be noted over time by a drop in head or flow or an increase in power required. Performance can usually be renewed by adjusting the impeller clearance. Two techniques are given to set the impeller clearance, the dial indicator method and the feeler gauge method.

DIAL INDICATOR METHOD

1. Remove coupling guard. Refer to coupling guard instructions Appendix II.
2. Remove coupling.
3. Set indicator so that button contacts either the shaft end or against face of coupling (Fig. 19).
4. Loosen jam nuts (423B) on jack bolts (371A) and back bolts out about two turns.
5. Tighten each locking bolt (370C) evenly, drawing the bearing housing (134A) towards the bearing frame (228) until impeller contacts the casing. Turn the shaft to ensure contact is made.
6. Set indicator to zero and back locking bolt (370C) out about one turn.
7. Thread jack bolts (371A) in until they evenly contact the bearing frame. Tighten the jack bolts evenly (about one flat at a time) backing the bearing housing (134A) away from the bearing frame until the indicator shows the proper clearance per Table 3.
8. Evenly tighten locking bolts (370C), then jack bolts (371A) keeping indicator reading at proper setting.
9. Check shaft for free turning.
10. Replace coupling guard.

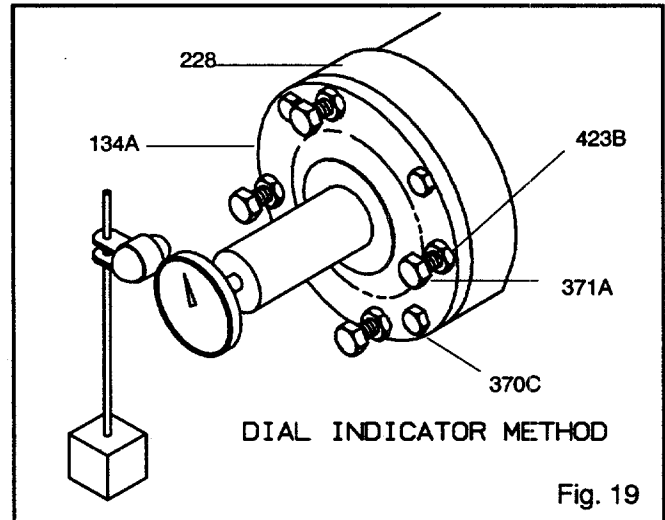

FEELER GAUGE METHOD

1. Remove coupling guard. Refer to coupling guard instructions in Appendix II.
2. Loosen jam nuts (423B) on jack bolts (371A) and back bolts out about two turns (Fig. 20).
3. Tighten locking bolts (370C) evenly, drawing bearing housing (134A) towards frame (228) until impeller contacts the casing. Turn shaft to ensure contact is made.
4. With a feeler gauge set the gap between the three locking bolts (370C) and bearing housing (134A) per impeller clearances in Table 3.
5. Evenly back out bearing housing (134A) using the three jack bolts (371A) until it contacts the locking bolts (370C). Evenly tighten jam nuts (423B).
6. Check shaft for free turning.
7. Replace coupling guard.

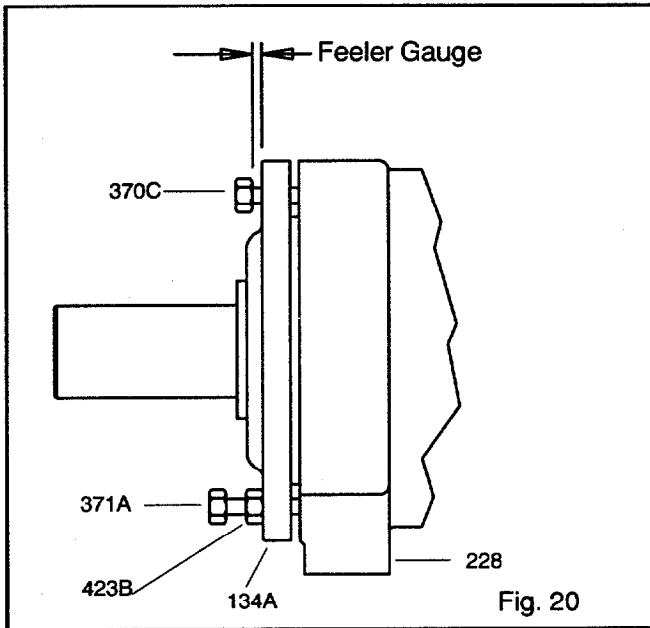

Table 3 Impeller Clearances

| COLD TEMPERATURE CLEARANCES FOR VARIOUS SERVICE TEMPERATURES | |
|---|---------------------|
| 200°F (93°C) | 0.015 in. (0.38 mm) |
| 250°F (121°C) | 0.017 in. (0.43 mm) |
| 300°F (149°C) | 0.019 in. (0.48 mm) |
| 350°F (177°C) | 0.021 in. (0.53 mm) |
| 400°F (204°C) | 0.023 in. (0.58 mm) |
| Over 400°F (204°C) | 0.025 in. (0.64 mm) |

TROUBLE SHOOTING

Table 7 Troubleshooting Pump

| PROBLEM | PROBABLE CAUSE | REMEDY |
|---|---|--|
| No liquid delivered. | Pump not primed. | Reprime pump, check that pump and suction line are full of liquid. |
| | Suction line clogged. | Remove obstructions. |
| | Impeller clogged with foreign material. | Back flush pump to clean impeller. |
| | Wrong direction of rotation. | Change rotation to concur with direction indicated by arrow on bearing housing or pump casing. |
| | Foot valve or suction pipe opening not submerged enough. | Consult factory for proper depth. Use baffle to eliminate vortices. |
| | Suction lift too high. | Shorten suction pipe. |
| Pump not producing rated flow or head. | Air leak thru gasket. | Replace gasket. |
| | Air leak thru stuffing box | Replace or readjust packing/mechanical seal. |
| | Impeller partly clogged. | Back flush pump to clean impeller. |
| | Worn suction sideplate or wear rings. | Replace defective part as required. |
| | Insufficient suction head. | Ensure that suction line shutoff valve is fully open and line is unobstructed. |
| | Worn or broken impeller. | Inspect and replace if necessary. |
| Pump starts then stops pumping. | Improperly primed pump. | Reprime pump. |
| | Air or vapor pockets in suction line. | Rearrange piping to eliminate air pockets. |
| | Air leak in suction line. | Repair (plug) leak. |
| Bearings run hot. | Improper alignment. | Re-align pump and driver. |
| | Improper lubrication. | Check lubricant for suitability and level. |
| | Lube cooling. | Check cooling system. |
| Pump is noisy or vibrates. | Improper pump/driver alignment. | Align shafts. |
| | Partly clogged impeller causing imbalance. | Back-flush pump to clean impeller. |
| | Broken or bent impeller or shaft. | Replace as required. |
| | Foundation not rigid. | Tighten hold down bolts of pump and motor or adjust stilts. |
| | Worn bearings. | Replace. |
| | Suction or discharge piping not anchored or properly supported. | Anchor per Hydraulic Institute Standards Manual recommendations |
| | Pump is cavitating. | System problem. |
| Excessive leakage from stuffing box. | Packing gland improperly adjusted. | Tighten gland nuts. |
| | Stuffing box improperly packed. | Check packing and repack box. |
| | Worn mechanical seal parts. | Replace worn parts. |
| | Overheating mechanical seal. | Check lubrication and cooling lines. |
| | Shaft sleeve scored. | Remachine or replace as required. |
| Motor requires excessive power. | Head lower than rating. Pumps too much liquid. | Consult factory. Install throttle valve, trim impeller diameter. |
| | Liquid heavier than expected. | Check specific gravity and viscosity. |
| | Stuffing packing too tight. | Readjust packing. Replace if worn. |
| | Rotating parts bind. | Check internal wearing parts for proper clearances. |

DISASSEMBLY & REASSEMBLY

| | |
|--------------------------|----|
| REQUIRED TOOLS | 35 |
| DISASSEMBLY | 35 |
| INSPECTIONS | 46 |
| REASSEMBLY | 51 |

REQUIRED TOOLS

- 9/16", 3/4", 7/8", 15/16" Open end wrenches
- Lifting sling
- Impeller wrench
STX, MTX - Goulds part # A01676A
STX, MTX, LTX, XLT-X, X17 -
Goulds part # A05107A
- 7/16" open end wrench (LTX)
- Induction bearing heater
- Brass drift punch
- Spanner wrench
- Snap-ring pliers
- Allen wrenches
- Torque wrench with sockets
- Dial indicator
- Micrometer
- Cleaning Agents
- Feeler gauges

6

DISASSEMBLY



WARNING

Pump components can be heavy. Proper methods of lifting must be employed to avoid physical injury and/or equipment damage. Steel toed shoes must be worn at all times.



WARNING

The 3196 may handle hazardous and/or toxic fluids. Proper personal protective equipment should be worn. Precautions must be taken to prevent physical injury. Pumpage must be handled and disposed of in conformance with applicable Environmental Regulations.

NOTE: *Before disassembling the pump for overhaul, ensure all replacement parts are available.*



WARNING

Lock out power supply to driver motor to prevent accidental startup and physical injury.

1. Shut off all valves controlling flow to and from pump.



WARNING

Operator must be aware of pumpage and safety precautions to prevent physical injury.

2. Drain liquid from piping, flush pump if necessary.
3. Disconnect all auxiliary piping and tubing.
4. Remove coupling guard. Refer to Coupling Guard Installation and Disassembly Section in Appendix 2.

5. Disconnect Coupling.
6. Remove coupling guard pump endplate.
7. If oil lubricated, drain oil from bearing frame by removing bearing frame drain plug (408A). Replace plug after oil is drained. Remove oil reservoir, if equipped (Fig. 21).

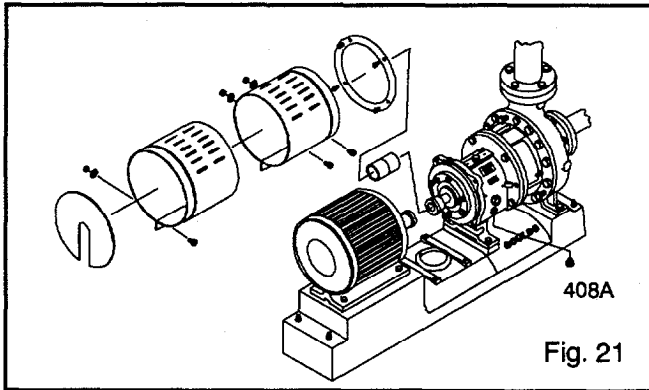

Fig. 21

NOTE: Oil analysis should be part of a preventive maintenance program, and is helpful to determine cause of a failure. Save oil in a clean container for inspection.

8. Place sling from hoist through frame adapter (108) or frame (228A) for STX (Fig. 22).
9. Remove bearing frame foot hold down bolts (370F).
10. Remove casing bolts (370).

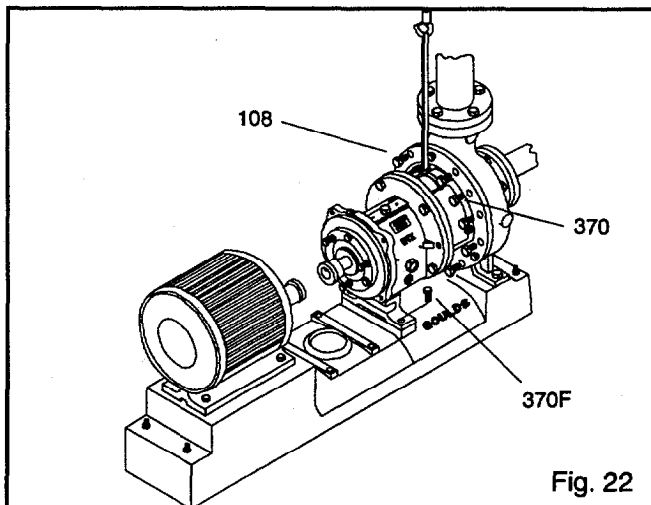

Fig. 22



WARNING

Never apply heat to remove parts. Use of heat may cause an explosion due to trapped fluid, resulting in severe physical injury and property damage.

11. Remove back pull-out assembly from casing (100). Tighten jack screws (418) evenly to remove back pull-out assembly (Fig. 23).

NOTE: Penetrating oil can be used if adapter to casing joint is excessively corroded.

NOTE: Remove and then mark shims from under frame foot. Save for reassembly.



WARNING

Never remove the back pull-out assembly unassisted, physical injury can occur.

12. Remove casing gasket (351) and discard. (Replace with new gasket during reassembly.)
13. Remove jack screws (418).

NOTE: Casing gasket (351) may partially adhere to casing due to binders and adhesives in the gasket material. Clean all gasket surfaces.

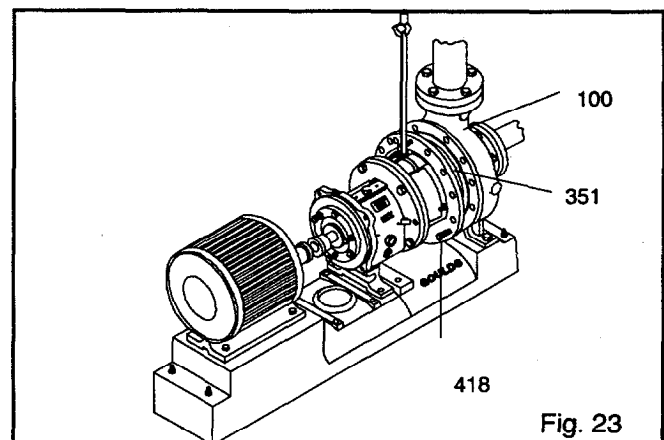

Fig. 23

14. Move back pull-out assembly to clean work bench.
15. Support frame adapter (108) securely to workbench.

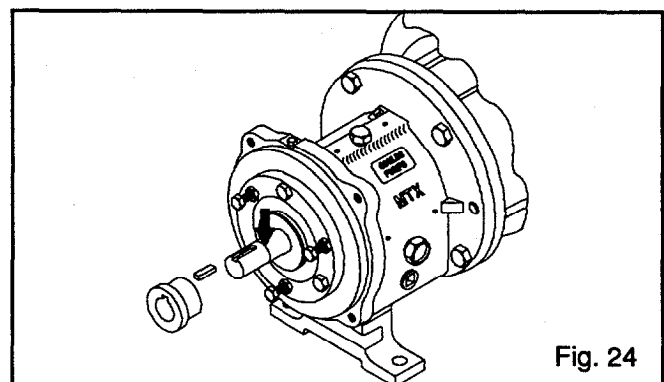

Fig. 24

NOTE: Blue and scribe shaft for relocating coupling hub during reassembly.

16. Remove coupling hub (Fig. 24).

Removal of Impeller



WARNING

Never apply heat to remove impeller. Use of heat may cause an explosion due to trapped fluid, resulting in severe physical injury and property damage.



WARNING

Wear heavy work gloves when handling impeller (101) as sharp edges may cause physical injury.

Two special features have been incorporated into the XLT design to ease maintenance problems and preclude the temptation to apply heat to stubborn parts.

1. A plug has been added to the nose of the XLT impellers. It is sealed with a teflon gasket. Removing the plug relieves any pressure between the impeller and the shaft and provides means to introduce penetrating oil to the threads to ease impeller removal.
2. A hexagonal nut is cast on the impeller hub so a socket wrench can be used to assist removal.

17. Recommended removal procedure is as follows:

STX, MTX, LTX: Remove impeller (101) from shaft (122). Slide Goulds shaft wrench (A05107A) over shaft (122) and key. Rotate impeller clockwise (viewed from impeller end of shaft) raising wrench off work surface. Quickly turn impeller (101) counterclockwise (viewed from impeller end of shaft) impacting wrench handle on workbench or solid block until impeller (101) loosens (Fig. 25).

XLT-X & X17: Remove plug (458Y) from front of impeller (101) and discard teflon gasket (428D) (Fig. 25A). Spray penetrating oil through plug hole into cavity at end of shaft. Wait 15 minutes. Rotate shaft several times while waiting to distribute oil. Proceed to remove impeller from shaft as described above for STX, MTX, and LTX. If impeller cannot be loosened after several tries, place socket wrench over cast nut on impeller hub and turn impeller counterclockwise (viewed from impeller end of shaft). Be sure impeller wrench is resting on workbench or solid block and the powerend is secure on workbench. It is further recommended that the frame foot (241) be clamped to the workbench when using this method to remove the impeller.

NOTE: FOR ALL MODELS

If the impeller cannot be removed by the previous methods, cut the shaft between the gland and the frame, remove the impeller, stuffing box cover, gland, sleeve and shaft end as a unit. Do not use heat.

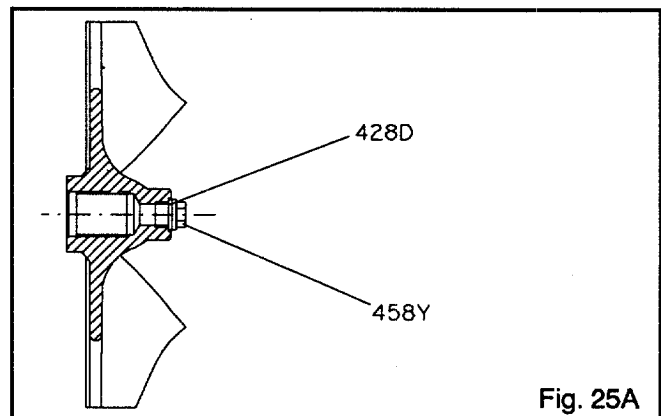
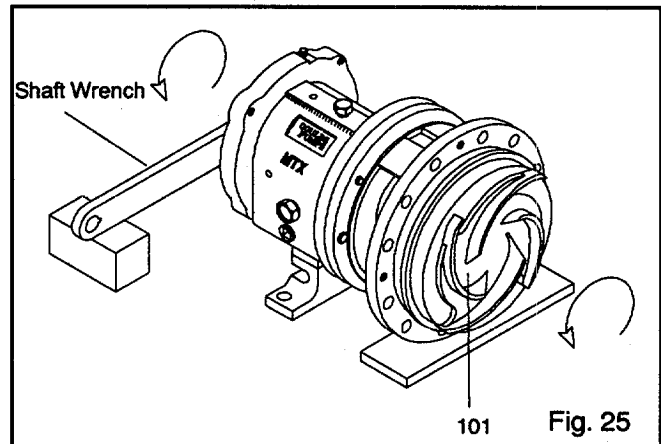

18. Remove impeller O-ring (412A) and discard (Fig. 26).

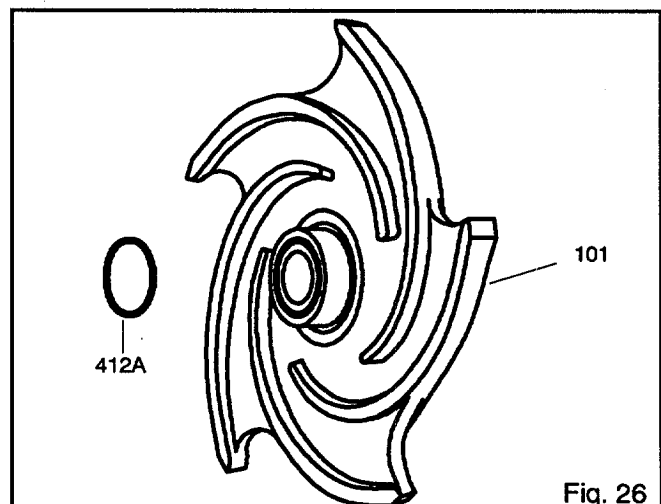

19. REMOVAL OF SEAL CHAMBER COVER

(Mechanical Seal)

1. Remove gland stud nuts (355).
2. Remove seal chamber stud nuts (370H).
3. Remove seal chamber (184).

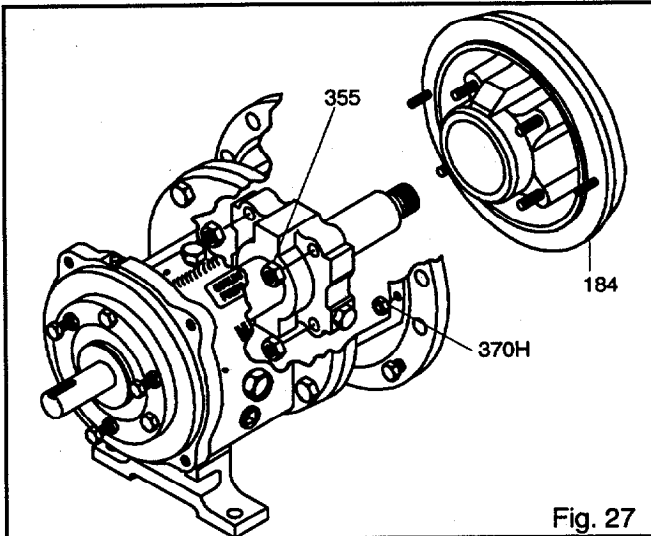

Fig. 27

4. Remove shaft sleeve (126), if used.

NOTE Mechanical seal is attached to sleeve (126). Rotary portion of seal needs to be removed from sleeve by loosening set screws and sliding it off the sleeve. Refer to mechanical seal instructions.

5. Remove gland (107) with stationary seat and O-ring (360Q) (Fig. 28).

NOTE: Be careful not to damage the stationary portion of the mechanical seal. It is seated in the gland bore.

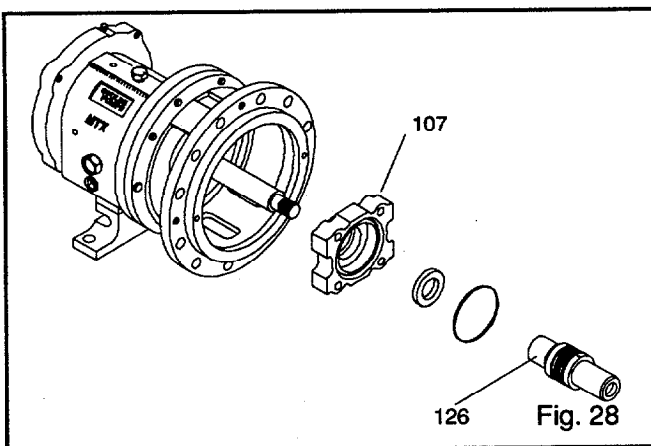

Fig. 28

19A. REMOVAL OF STUFFING BOX COVER

(Packed Box) (Fig. 29)

1. Remove gland stud nuts (355), and gland (107).
2. Remove stuffing box cover stud nuts (370H).
3. Remove stuffing box cover (184).

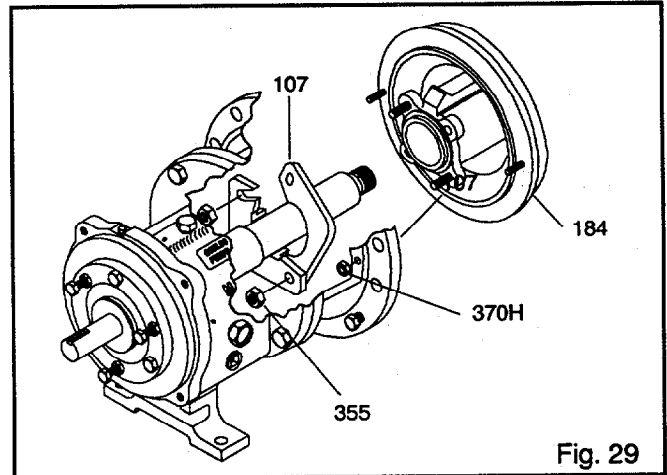

Fig. 29

4. Remove shaft sleeve (126) (Fig. 30).

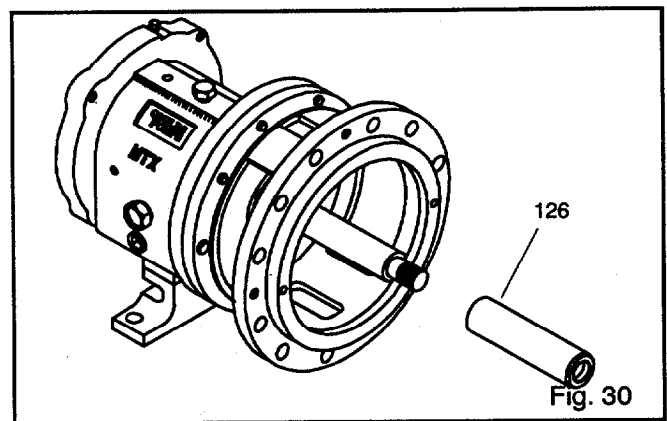

Fig. 30

5. Remove packing (106) and lantern ring (105) from stuffing box cover (184) (Fig. 31).

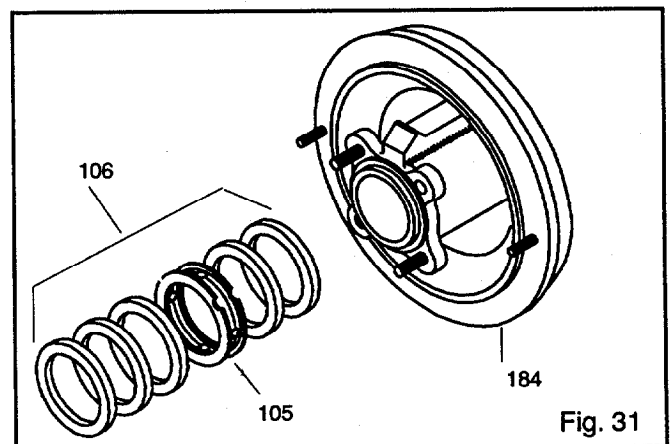
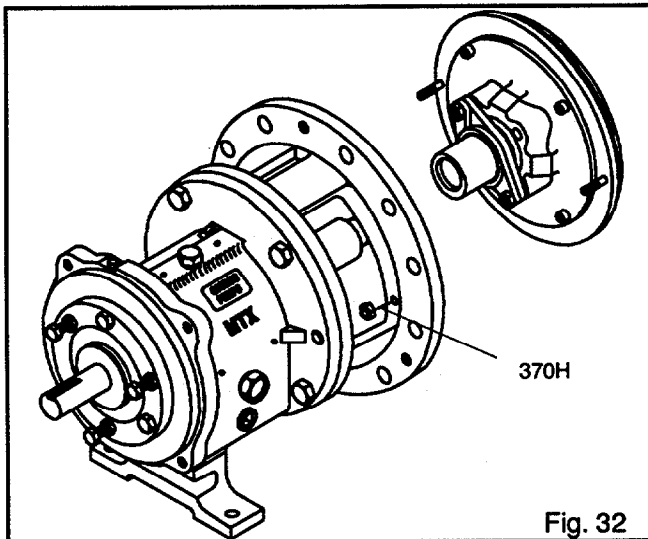

Fig. 31

19B. REMOVAL OF DYNAMIC SEAL

1. Remove stud nuts (370H).
2. Remove dynamic seal assembly (Fig. 32).



3. Remove socket head cap screws (265) (Fig. 33).
4. Remove stuffing box cover (184) and gasket (264).
5. Remove repeller (262) from backplate (444).

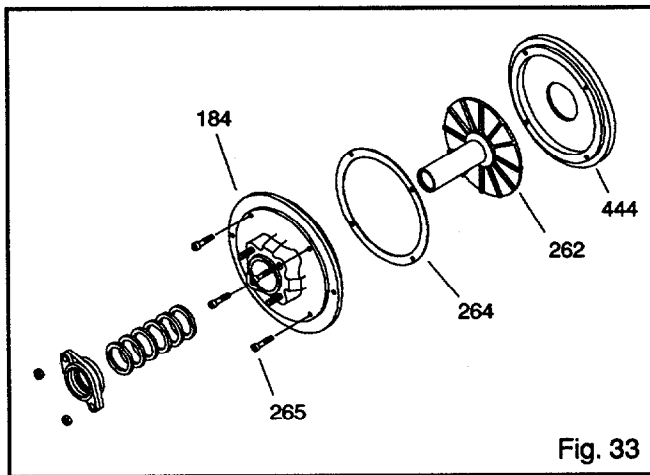

20. REMOVE FRAME ADAPTER - MTX, LTX, XLT-X, X17

1. Remove dowel pins (469B), and bolts (370B).
2. Remove frame adapter (108) (Fig. 34).
3. Remove and discard gasket (360D). Replace with new gasket during reassembly.

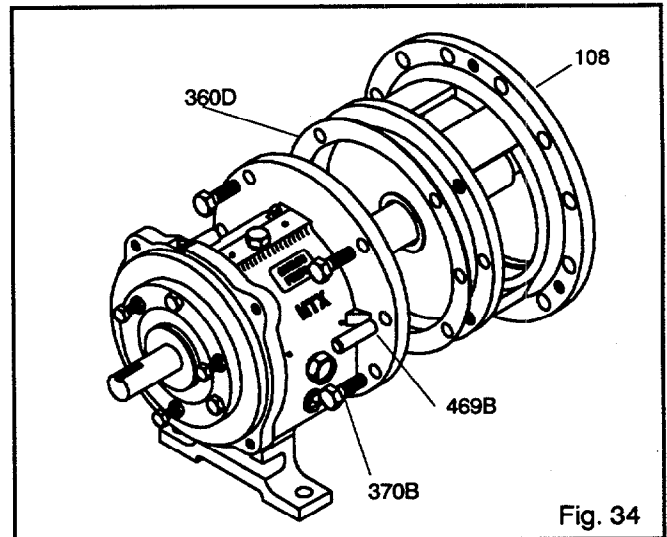

21. Remove inboard labyrinth oil seal (333A), it is an O-Ring fit into the bearing frame (228A) for STX, frame adapter (108) for MTX, LTX, XLT-X and X17. Remove O-rings (497H), (497J) if necessary (Fig. 35).

NOTE: Labyrinth oil seal O-rings (497H, J) are part of 3196 maintenance kits or can be obtained separately

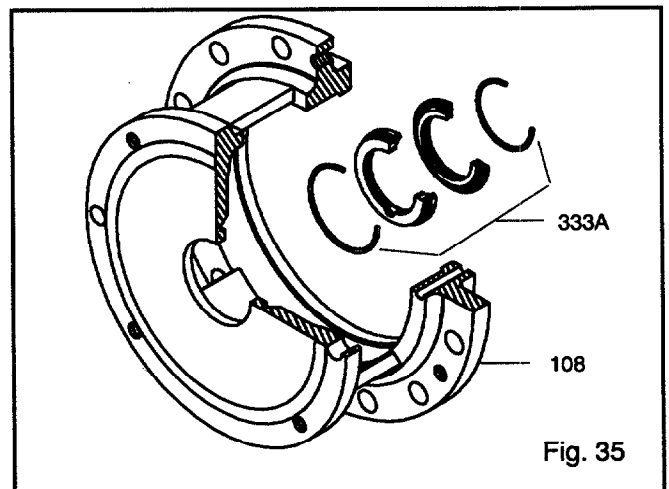

22A. DISASSEMBLY OF POWER END - STX, MTX

1. Remove clamp screws (370C). Back off jam nuts (423). Tighten jack screws (370D) evenly, this will start bearing housing (134) out of bearing frame (228A) (Fig. 36).
2. Remove the shaft assembly from the bearing frame (228A).

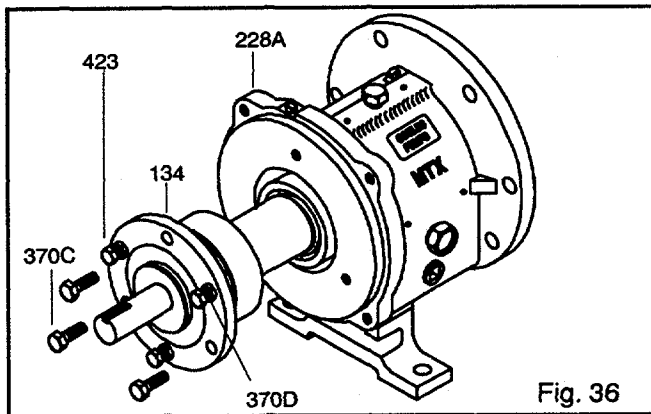

3. Remove jack screws (370D) with nuts (423) (Fig. 37).
4. Remove bearing housing O-ring (469).
5. Remove outboard bearing retaining snap ring (316A).

NOTE: Snap ring cannot be removed from the shaft until bearings are removed.

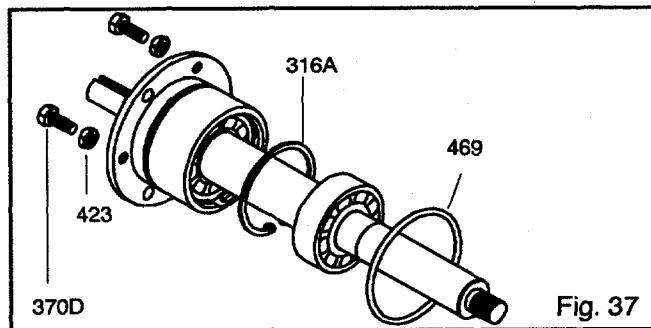

6. Remove bearing housing (134) from shaft (122) with bearings (112A, 168A) (Fig. 38).

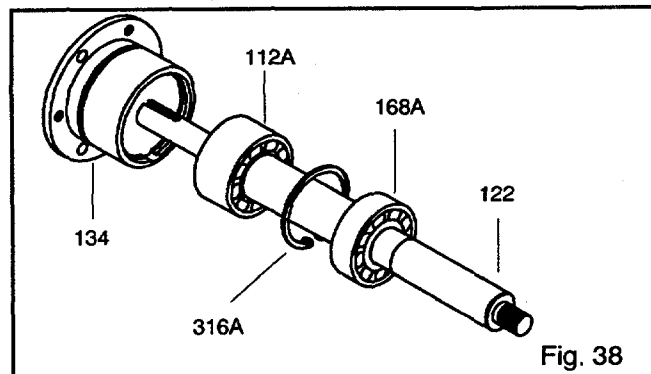

7. Remove outboard labyrinth seal (332A) from bearing housing (134). Remove O-rings (497F), (497G) if necessary (Fig. 39).

NOTE: Labyrinth oil seal O-rings (497F, G) are part of 3196 maintenance kits or can be obtained separately

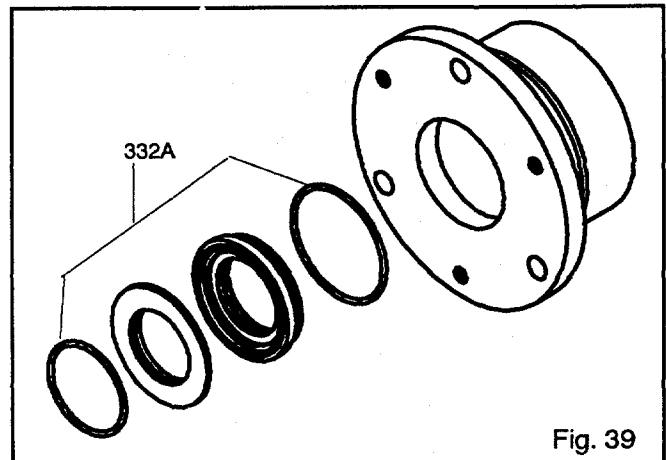

8. Remove bearing locknut (136) and bearing lock washer (382) (Fig. 40).
9. Remove inboard bearing (168A).
10. Remove outboard bearing (112A).

NOTE: When pressing bearings off shaft, use force on inner race only.

NOTE: Save bearings for inspection.

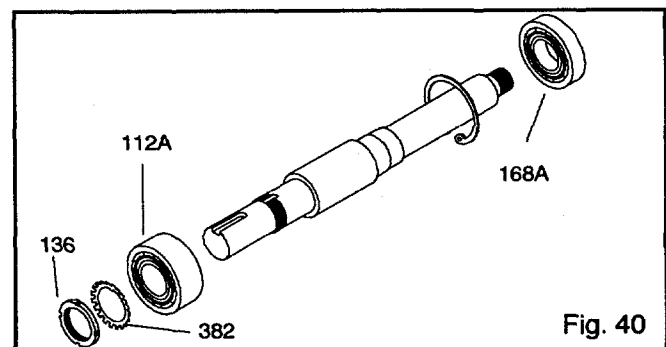

22B. DISASSEMBLY OF POWER END - LTX

1. Remove clamp screws (370C). Back off jam nuts (423). Tighten jack screws (370D) evenly, this will start bearing housing (134) out of bearing frame (228A) (Fig. 41).
2. Remove shaft assembly from bearing frame (228A).

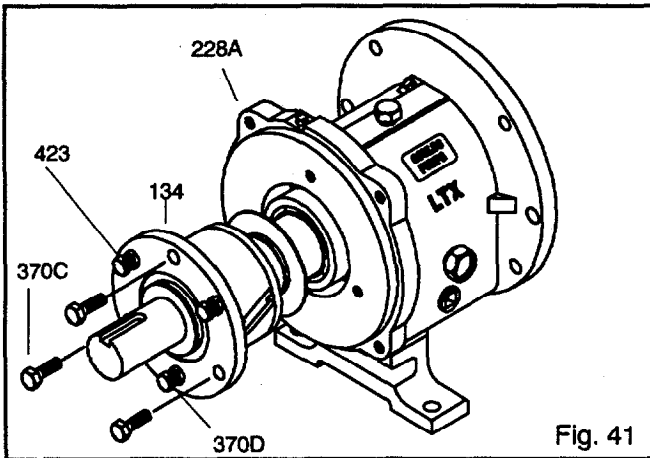

Fig. 41

3. Remove jack screws (370D) with nuts (423) (Fig. 42).
4. Remove clamp ring screws (236A). Separate clamp ring (253B) from bearing housing (134).

NOTE: Clamp ring cannot be removed from the shaft until bearings are removed.

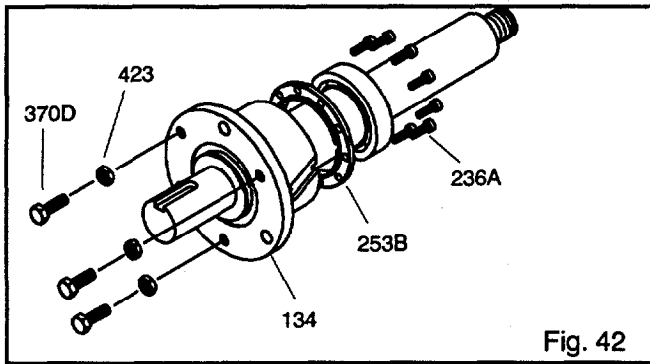

Fig. 42

5. Remove bearing housing (134) from shaft (122) with bearings (112A, 168A) (Fig. 43A).
6. Remove bearing housing O-ring (469).

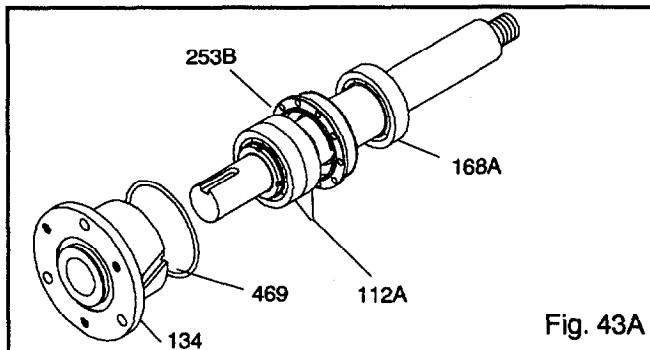

Fig. 43A

7. Remove inboard bearing (168A) (Fig. 43B).
8. Remove bearing locknut (136) and bearing lockwasher (382).
9. Remove outboard bearings (112A). Remove clamp ring (253B)

NOTE: When pressing bearings off shaft, use force on inner race only.

NOTE: Save bearings for inspection. Do not reuse bearings.

NOTE: Do not remove oil flinger (248A) unless it is damaged.

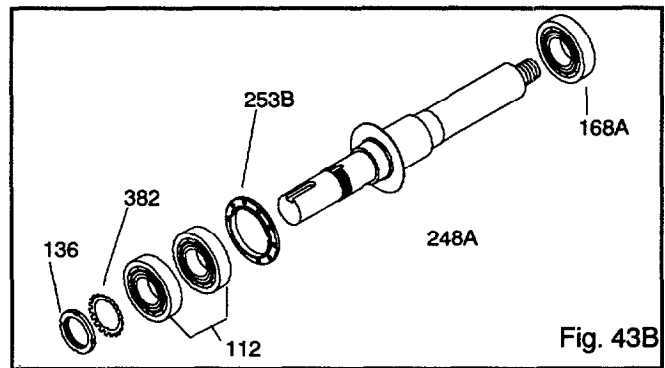

Fig. 43B

10. Remove outboard labyrinth seal (332A) from bearing housing (134). Remove O-rings (497F), (497G) if necessary (Fig. 44).

NOTE: Labyrinth oil seal O-rings (497F, G) are part of 3196 maintenance kits or can be obtained separately

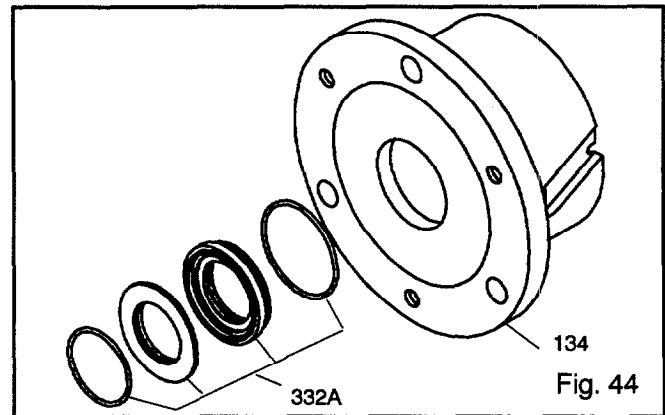
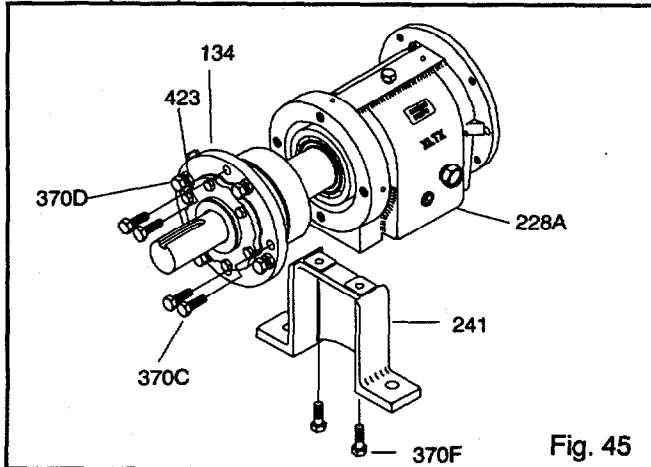

Fig. 44

22C. DISASSEMBLY OF THE POWER END - XLT-X, X17

1. Remove bearing frame to frame foot bolts (370F) and frame foot (241) (Fig. 45).
2. Remove clamp screws (370C). Back off jam nuts (423). Tighten jack screws (370D) evenly, this will start bearing housing (134) out of bearing frame (228A),
3. Remove shaft assembly from bearing frame (228A).



4. Remove jack screws (370D) with nuts (423) (Fig. 46).
5. Remove bearing housing O-ring (469).
6. Remove inboard bearing (168A).

NOTE: When pressing bearings off shaft, use force on inner race only.

NOTE: Save bearings for inspection.

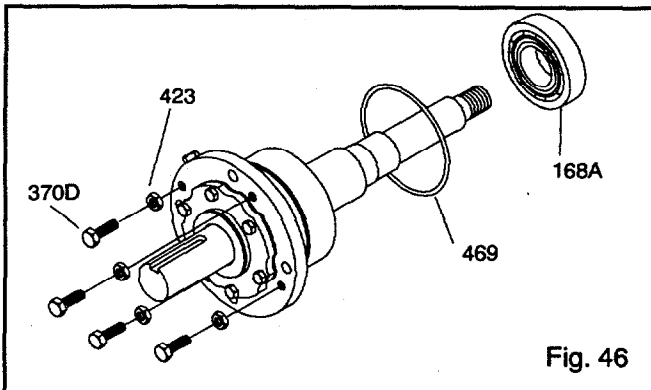

7. Remove bolts (371C), bearing end cover (109A) and gasket (360C) (Fig. 47).
8. Remove outboard labyrinth seal (332A) from end cover (109A). Remove O-rings (497F), (497G) if necessary.

NOTE: Labyrinth oil seal O-rings (497F, G) are part of 3196 maintenance kits or can be obtained separately

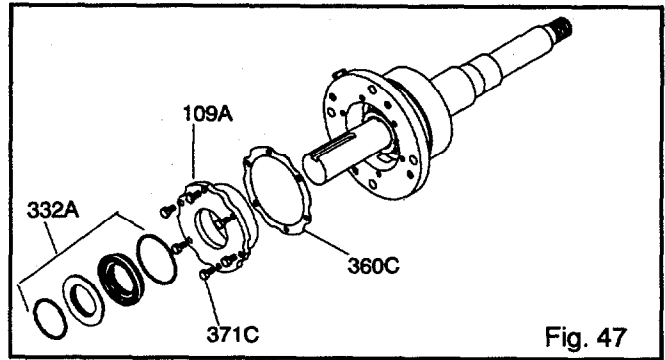

9. Remove bearing housing (134) from shaft (122) with bearing (112A) (Fig. 48).

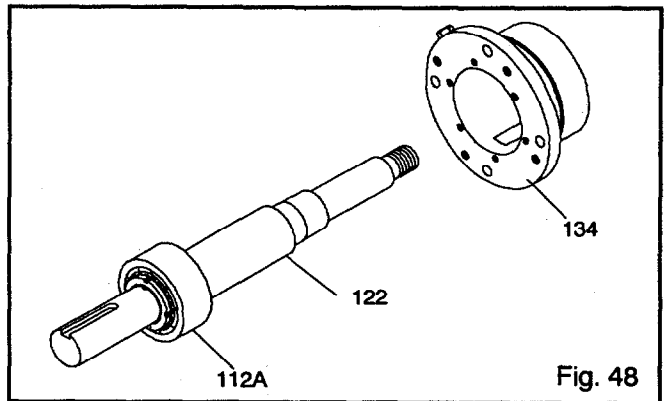

10. Remove bearing locknut (136) and bearing lockwasher (382) (Fig. 49).
11. Remove outboard bearing (112A).

NOTE: When pressing bearings off shaft, use force on inner race only.

NOTE: Save bearings for inspection.

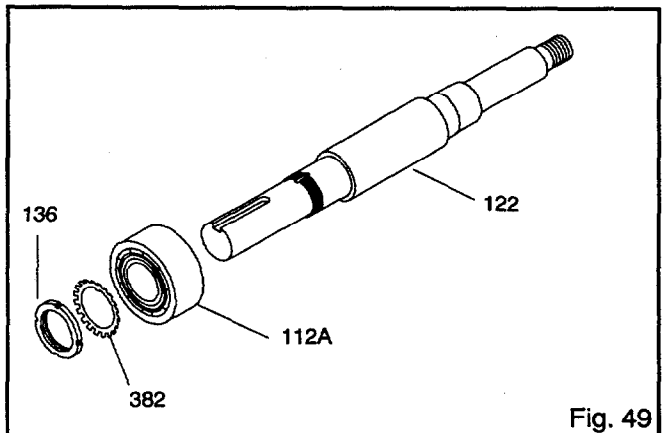

**22D. DISASSEMBLY OF POWER END -
STX, MTX with Duplex Bearings**

1. Remove clamp screws (370C). Back off jam nuts (423). Tighten jack screws (370D) evenly, this will start bearing housing (134) out of bearing frame (228A) (Fig. 50).
2. Remove shaft assembly from bearing frame (228A).

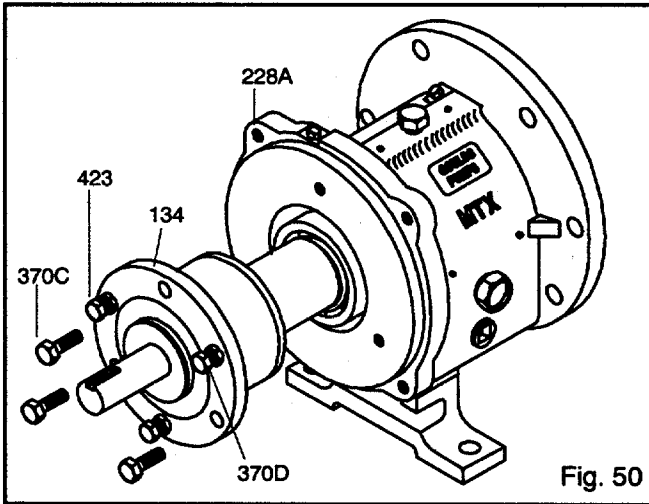

3. Remove jack screws (370D) with nuts (423) (Fig. 51).
4. Remove bearing housing O-ring (469).
5. Remove clamp ring screws (236A). Separate clamp ring (253B) from bearing housing (134).

NOTE: Clamp ring cannot be removed from the shaft until bearings are removed.

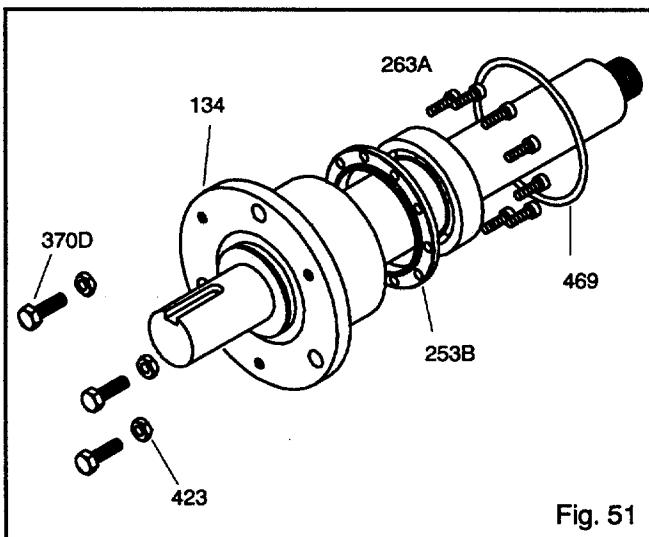

6. Remove bearing housing (134) from shaft (122) with bearings (112A, 168A) (Fig. 52).

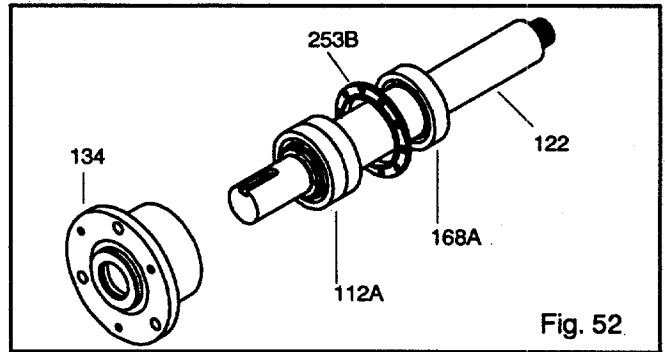

7. Remove inboard bearing (168A) (Fig. 53).
8. Remove bearing locknut (136) and bearing lockwasher (382).
9. Remove outboard bearings (112A).

NOTE: When pressing bearings off shaft, use force on inner race only.

NOTE: Save bearings for inspection.

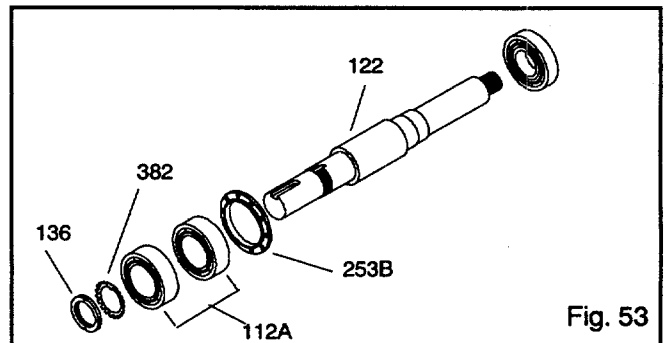

10. Remove outboard labyrinth seal (332A) from bearing housing (134). Remove O-rings (497F), (497G) if necessary (Fig. 54).

NOTE: Labyrinth oil seal O-rings (497F, G) are part of 3196 maintenance kits or can be obtained separately

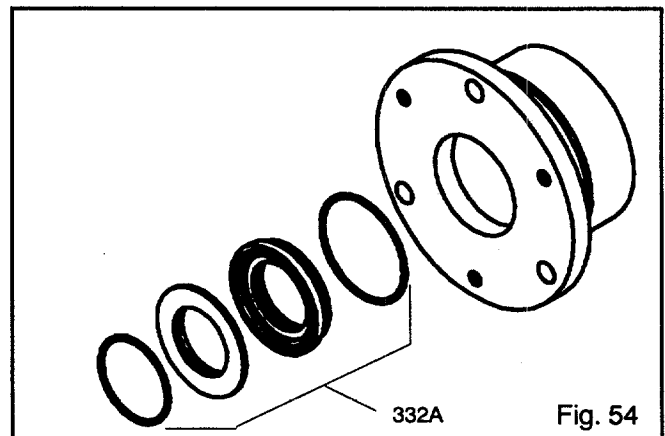

6

22E. DISASSEMBLY OF POWER END - XLT-X, X17 with Duplex Bearings

1. Remove bearing frame to frame foot bolts (370F) and frame foot (241) (Fig. 55).
2. Remove clamp screws (370C). Back off jam nuts (423). Tighten jack screws (370D) evenly, this will start bearing housing (134) out of bearing frame (228A).
3. Remove shaft assembly from bearing frame (228A).

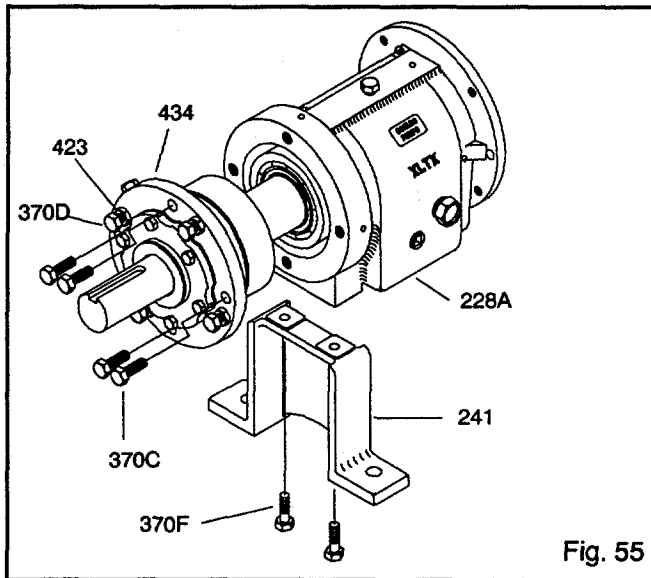

4. Remove jack screws (370D) with nuts (423) (Fig. 56).
5. Remove bearing housing O-ring (469).
6. Remove inboard bearing (168A).

NOTE: When pressing bearings off shaft, use force on inner race only.

NOTE: Save bearings for inspection.

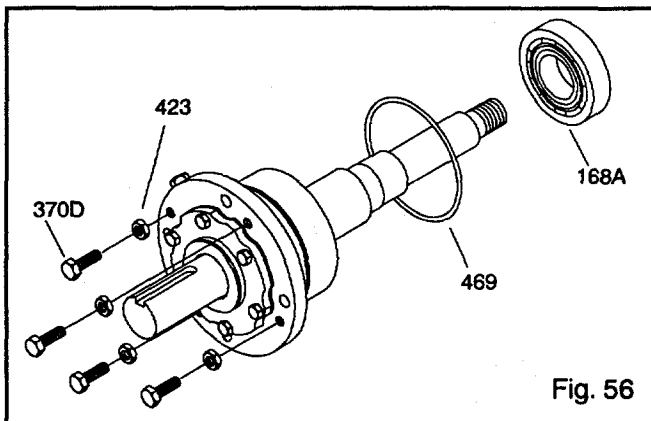

7. Remove bolts (371C), end cover (109A) and gasket (360C) (Fig. 57).

8. Remove outboard labyrinth seal (332A) from end cover (109A). Remove O-rings (497F), (497G) if necessary.

NOTE: Labyrinth oil seal O-rings (497F, G) are part of 3196 maintenance kits or can be obtained separately

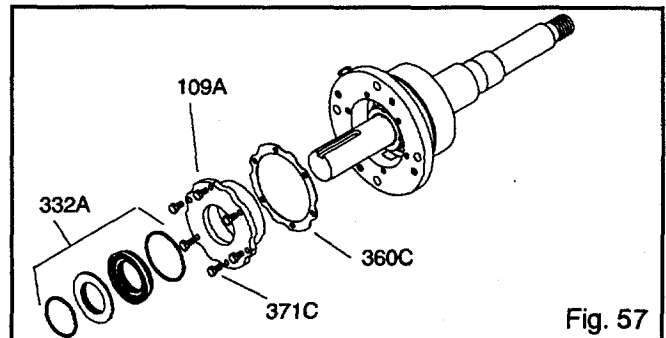

9. Remove bearing housing (134) from shaft (122) with bearings (112A) (Fig. 58).

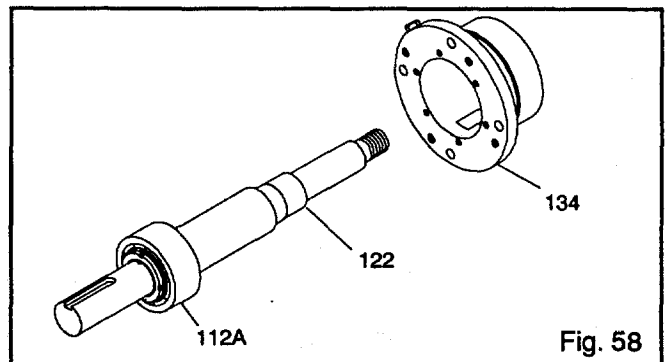

10. Remove bearing locknut (136) and bearing lockwasher (382) (Fig. 59).
11. Remove outboard bearing (112A).

NOTE: When pressing bearings off the shaft, use force on the inner race only.

NOTE: Save bearings for inspection.

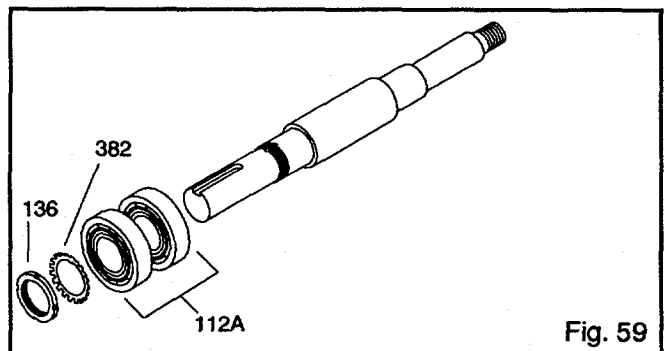
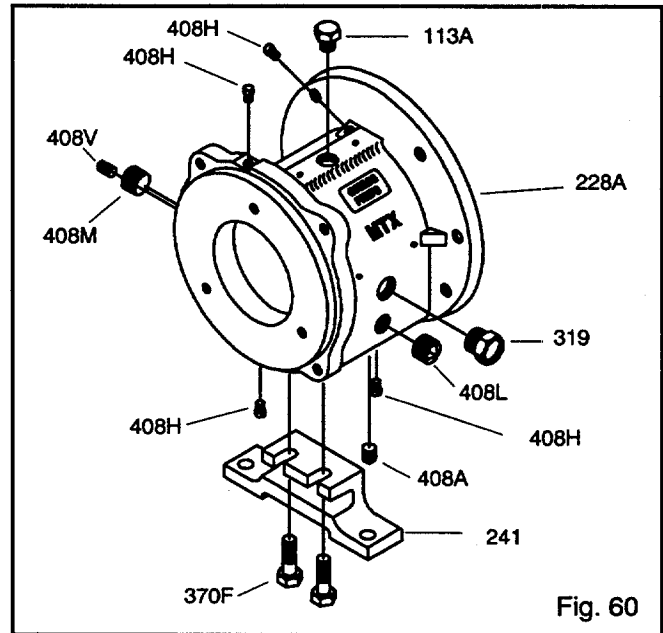

Fig. 59

ALL MODELS

23. DISASSEMBLY OF BEARING FRAME

1. Remove oil fill plug (113A), oil drain plug (408A), sight glass (319), sight oiler plug (408J), four (4) oil mist/grease connection plugs (408H), and oil cooler inlet and outlet plugs (408L, 408M) from bearing frame (228A).
2. MTX, LTX: Remove bearing frame foot-to-frame bolts (370F), and frame foot (241)
3. Proceed to Parts Inspection.



INSPECTIONS

The Model 3196 parts must be inspected to the following criteria before they are reassembled to insure the pump will run properly. Any part not meeting the required criteria should be replaced.

NOTE: Clean parts in solvent to remove oil, grease or dirt. Protect machined surfaces against damage during cleaning.

Casing

The casing (100) should be inspected for excessive wear or pitting. It should be repaired or replaced if it exceeds the following criteria (Fig. 61).

1. Localized wear or grooving greater than 1/8 in. (3.2 mm) deep.
2. Pitting greater than 1/8 in. (3.2 mm) deep.
3. Inspect case gasket seat surface for irregularities.

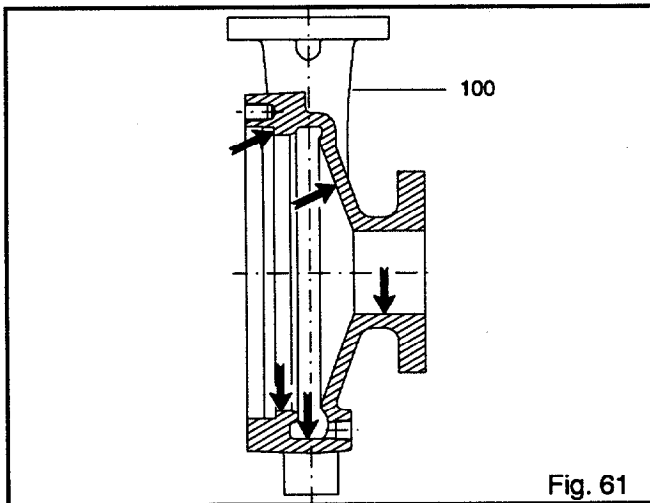

Fig. 61

Impeller

1. Inspect impeller (101) vanes for damage. Replace if grooved deeper than 1/16 in. (1.6 mm) or if worn evenly more than 1/32 in. (0.8 mm). (Area "a" in Fig. 62)
2. Inspect pumpout vanes for damage. Replace if worn more than 1/32 in. (0.8 mm). (Area "b" in Fig. 62)

3. Inspect leading and trailing edges of the vanes for pitting, and erosion or corrosion damage. (Area "c" in Fig. 62.).

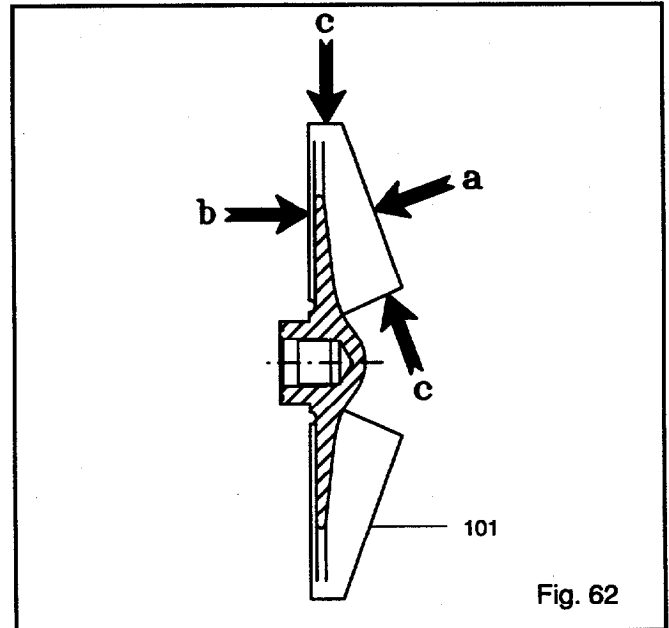

Fig. 62

Frame Adapter

1. Check frame adapter (108) for cracks or excessive corrosion damage. Replace if any of these conditions exist (Fig. 63).
2. Make sure gasket surface is clean.

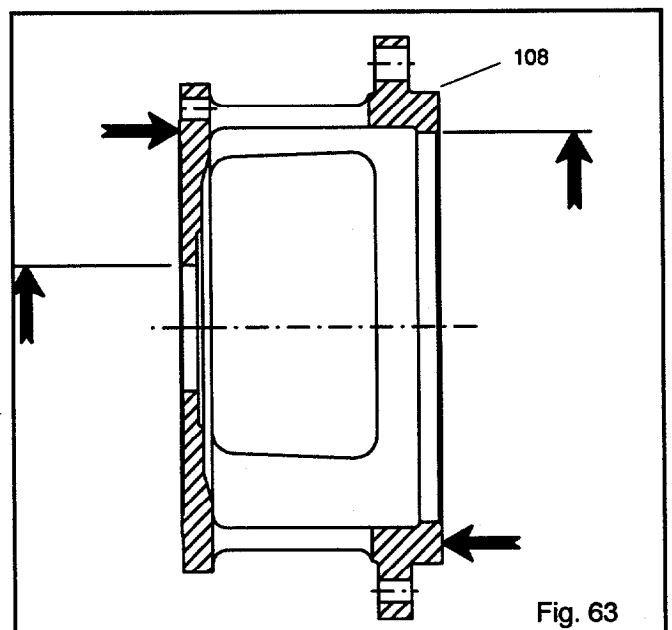
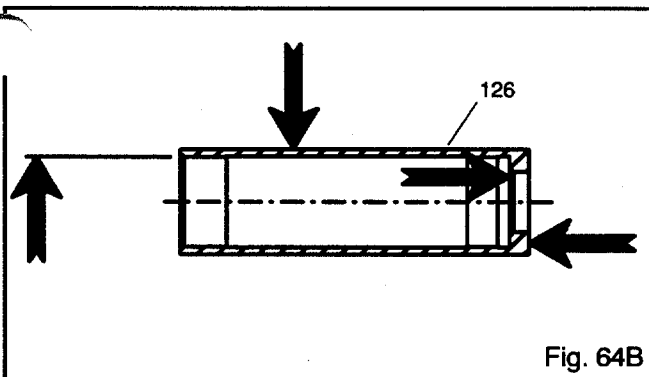
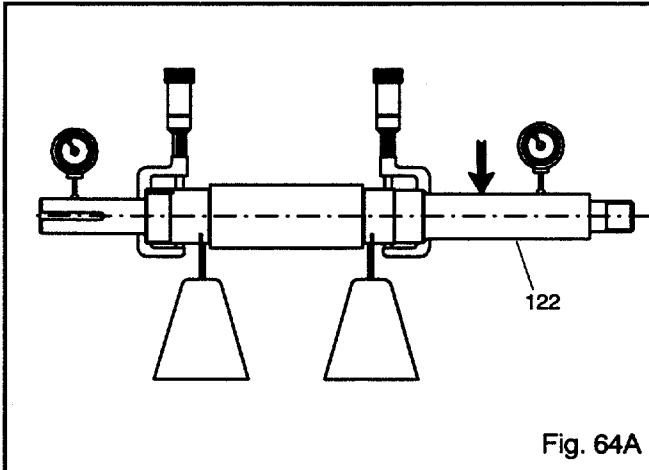

Fig. 63

Shaft and Sleeve

Check bearing fits. If any are outside the tolerance in Table 8, replace the shaft (122) (Fig. 64A).

2. Check shaft straightness. Replace shaft if runout exceeds values in Table 12.
3. Check shaft and sleeve (126) surface for grooves, pitting. Replace if any are found (Fig. 64B).



Bearing Frame

1. Visually inspect bearing frame (228) and frame foot (241) for cracks. Check frame inside surfaces for rust, scale or debris. Remove all loose and foreign material (Fig. 65,66).
2. Make sure all lubrication passages are clear.
3. If frame has been exposed to pumpage inspect for corrosion or pitting.

4. Inspect inboard bearing bore according to Table 2.

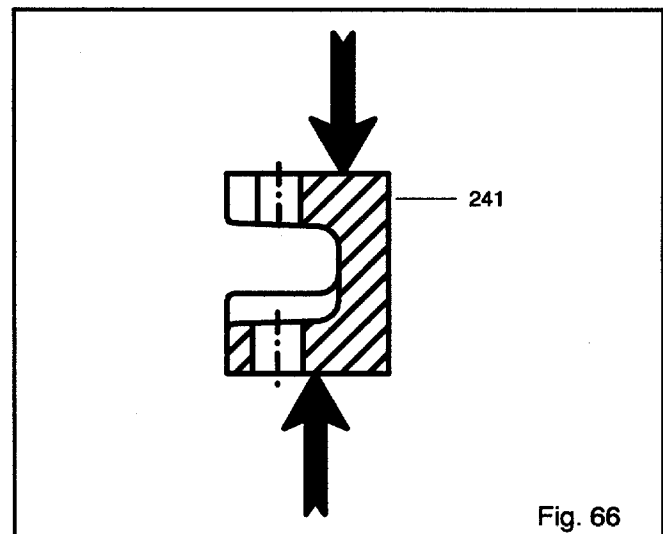
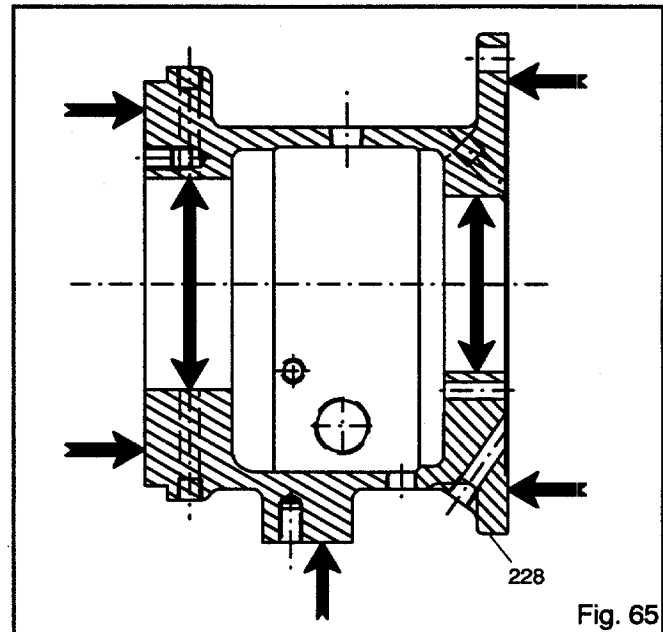

Dynamic Seal Repeller

1. Inspect dynamic seal repeller (262) vanes for damage. Replace if grooved deeper than 1/16 in. (1.6 mm) or if worn evenly more than 1/32 in. (0.8 mm) (Fig. 67).
2. Inspect sleeve surface for grooves, pitting or other damage. Replace if damaged.

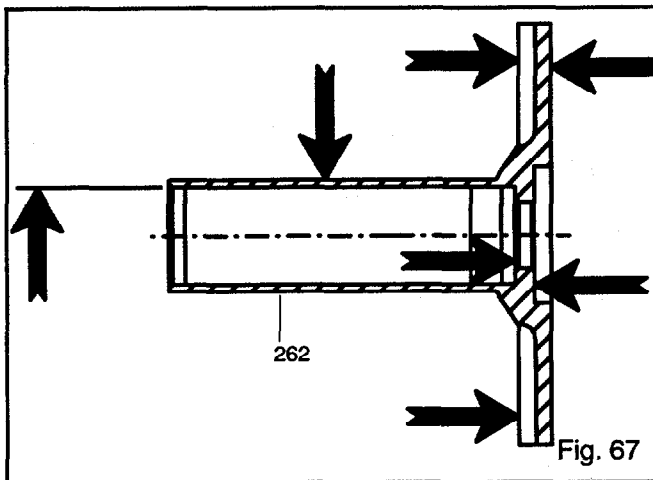

Seal Chamber/Stuffing Box Cover and Dynamic Seal Backplate

1. Make sure seal chamber/stuffing box cover (184) and dynamic seal backplate (444) gasket surface is clean, at adapter face (Fig. 68, 69, 70).
2. Replace if any pitting or wear greater than 1/8 in. (3.2 mm) deep.

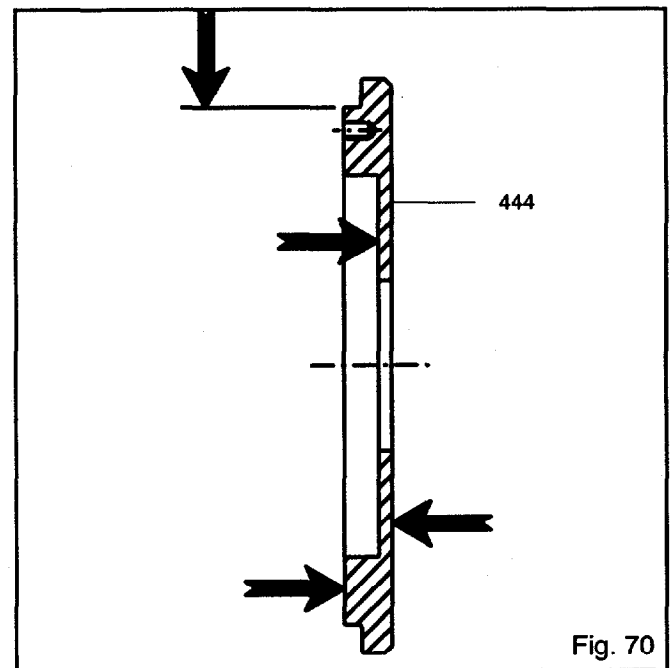
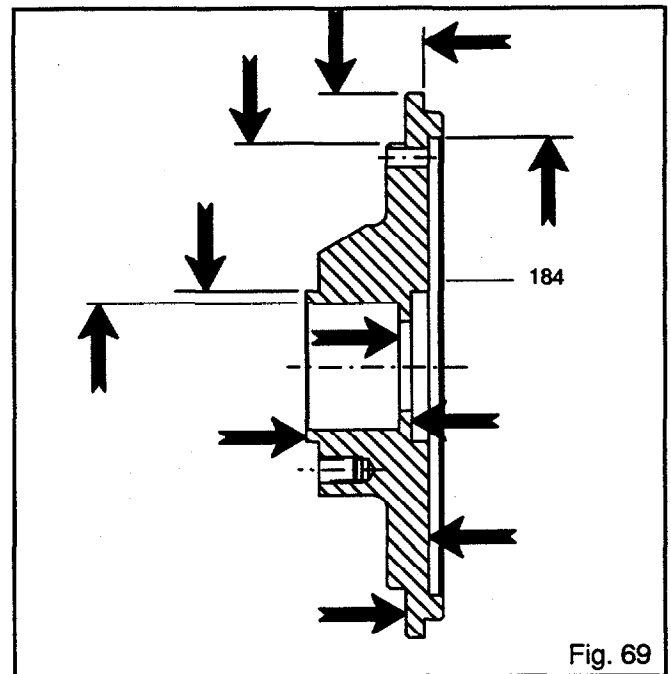
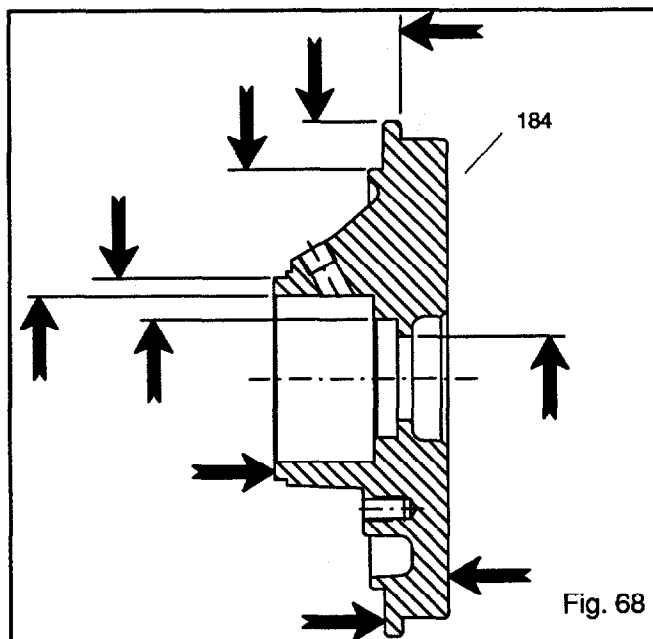

Bearings

1. Ball bearings (112A, 168A) should be inspected for contamination and damage. The condition of the bearings will provide useful information on operating conditions in the bearing frame. Lubricant condition and residue should be noted, oil analysis is often helpful. Bearing damage should be investigated to determine cause. If cause is not normal wear, it should be corrected before pump is returned to service.

DO NOT RE-USE BEARINGS.

Bearing Housing

1. Inspect bearing housing (134) bore according to Table 8. Replace if dimensions exceed Table 8 values.

2. Visually inspect for cracks and pits.

STX, MTX - Snap ring groove must not be cracked (Fig. 71).

LTX - Grooves and holes must be clear (Fig. 72).

XLT-X, X17 - Gasket surface must be clean (Fig. 73).

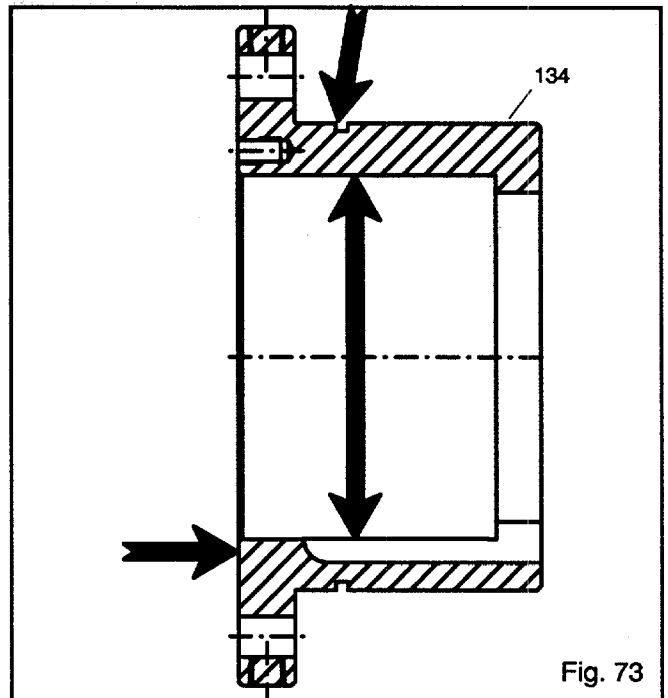
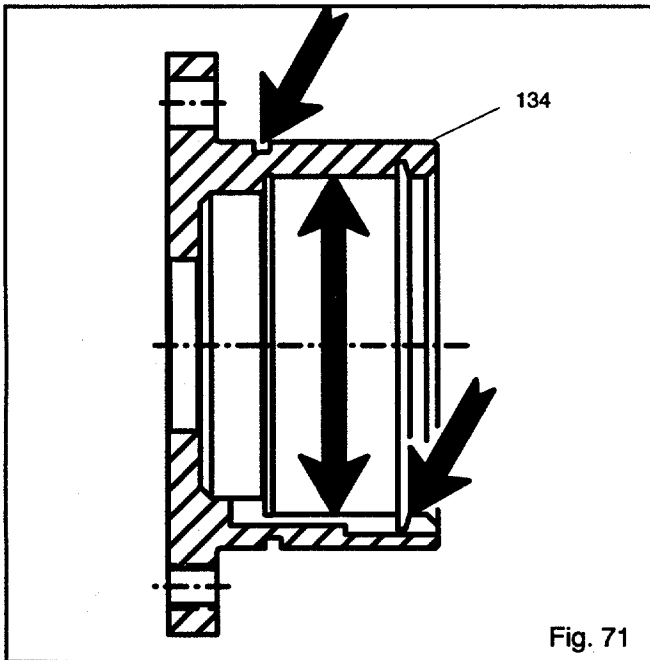

Labyrinth Seals

1. Labyrinth seal (332A, 333A) O-rings should be inspected for cuts and cracks. Replace as needed.

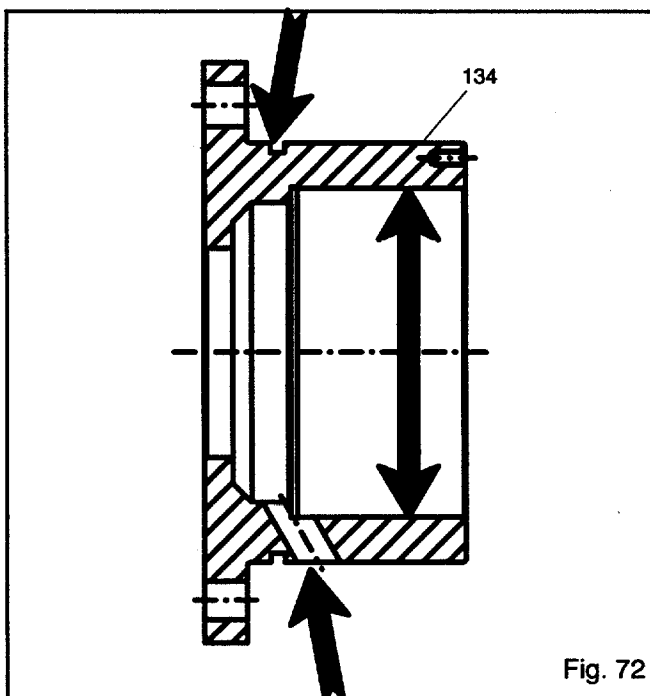

Table 8 3196 Bearing Fits & Tolerances

according to ABEC I standard

| | STX in. (mm) | MTX in. (mm) | LTX in. (mm) | XLT-X, X17 in. (mm) |
|--------------------------|--|--|--|--|
| Shaft O.D. Inboard | 1.3785 (35.013) 1.3781 (35.002) | 1.7722 (45.013) 1.7718 (45.002) | 2.1660 (55.015) 2.1655 (55.002) | 2.5597 (65.015) 2.5592 (65.002) |
| | 0.0010 (0.025) tight 0.0001 (0.002) tight | 0.0010 (0.025) tight 0.0001 (0.002) tight | 0.0012 (0.030) tight 0.0001 (0.002) tight | 0.0012 (0.030) tight 0.0001 (0.002) tight |
| Bearing I.D. Inboard | 1.3780 (35.000) 1.3775 (34.988) | 1.7717 (45.000) 1.7712 (44.988) | 2.1654 (55.000) 2.1648 (54.985) | 2.5591 (65.000) 2.5585 (64.985) |
| Frame I.D. Inboard | 2.8346 (72.000) 2.8353 (72.019) | 3.9370 (100.000) 3.9379 (100.022) | 4.7244 (120.000) 4.7253 (120.022) | 5.5118 (140.000) 5.5128 (140.025) |
| | 0.0012 (0.032) loose 0.0000 (0.000) loose | 0.0015 (0.037) loose 0.0000 (0.000) loose | 0.0015 (0.037) loose 0.0000 (0.000) loose | 0.0017 (0.043) loose 0.0000 (0.000) loose |
| Bearing O.D. Inboard | 2.8346 (72.000) 2.8341 (71.987) | 3.9370 (100.000) 3.9364 (99.985) | 4.7244 (120.000) 4.7238 (119.985) | 5.5118 (140.000) 5.5111 (139.982) |
| Shaft O.D. Outboard | 1.1815 (30.011) 1.1812 (30.002) | 1.7722 (45.013) 1.7718 (45.002) | 1.9690 (50.013) 1.9686 (50.002) | 2.5597 (65.015) 2.5592 (65.002) |
| | 0.0008 (0.021) tight 0.0001 (0.002) tight | 0.0010 (0.025) tight 0.0001 (0.002) tight | 0.0010 (0.025) tight 0.0001 (0.002) tight | 0.0012 (0.030) tight 0.0001 (0.002) tight |
| Bearing I.D. Outboard | 1.1811 (30.000) 1.1807 (29.990) | 1.7717 (45.000) 1.7712 (44.988) | 1.9685 (50.000) 1.9680 (49.988) | 2.5591 (65.000) 2.5585 (64.985) |
| Housing I.D. Outboard | 2.8346 (72.000) 2.8353 (72.019) | 3.9370 (100.000) 3.9379 (100.022) | 4.3307 (110.000) 4.3316 (110.022) | 5.5118 (140.000) 5.5128 (140.025) |
| | 0.0012 (0.032) loose 0.0000 (0.000) loose | 0.0015 (0.037) loose 0.0000 (0.000) loose | 0.0015 (0.037) loose 0.0000 (0.000) loose | 0.0017 (0.043) loose 0.0000 (0.000) loose |
| Bearing O.D. Outboard | 2.8346 (72.000) 2.8341 (71.987) | 3.9370 (100.000) 3.9364 (99.985) | 4.3307 (110.000) 4.3301 (109.985) | 5.5118 (140.000) 5.5111 (139.982) |

REASSEMBLY

Refer to Table 9 for torque values while reassembling pump.

Table 9 Bolt Torque Table

| LOCATION | LUBRICATED THREADS | DRY THREADS | |
|---|--------------------|---------------------|---------------------|
| CASING BOLTS (370) | 6" STX | 30 FT-LBS (40 N·m) | 45 FT-LBS (60 N·m) |
| | 8" STX | 20 FT-LBS (27 N·m) | 30 FT-LBS (40 N·m) |
| | MTX, LTX | 30 FT-LBS (40 N·m) | 45 FT-LBS (60 N·m) |
| | XLT-X, X17 | 30 FT-LBS (40 N·m) | 45 FT-LBS (60 N·m) |
| FRAME - TO - ADAPTER BOLTS (370B) | | 20 FT-LBS (27 N·m) | 30 FT-LBS (40 N·m) |
| BEARING CLAMP RING BOLTS (236A) Duplex Bearing Only | STX, MTX | 10 IN-LBS (1.1 N·m) | 17 IN-LBS (1.9 N·m) |
| | LTX | 55 IN-LBS (6.2 N·m) | 83 IN-LBS (9.4 N·m) |
| BEARING END COVER BOLTS (371C) | XLT-X, X17 | 9 FT-LBS (12 N·m) | 12 FT-LBS (16 N·m) |
| DYNAMIC SEAL CAP SCREWS (265) | STX, MTX LTX | 55 IN-LBS (6.2 N·m) | 83 IN-LBS (9.4 N·m) |
| | XLT-X, X17 | 9 FT-LBS (12 N·m) | 12 FT-LBS (16 N·m) |

Refer to Table 10 for shaft end play while reassembling pump.

Table 10 3196 Shaft End Play

| | STX in. (mm) | MTX in. (mm) | LTX in. (mm) | XLT-X, X17 in. (mm) |
|------------|------------------------------|------------------------------|------------------------------|------------------------------|
| Double Row | .0011 (.028) .0019 (.047) | .0013 (.033) .0021 (.054) | not applicable | .0014 (.036) .0023 (.058) |
| Duplex | .0007 (.018) .0010 (.026) | .0009 (.022) .0012 (.030) | .0010 (.026) .0015 (.038) | .0010 (.026) .0015 (.038) |

**Table 11
3196 Bearing Type**

| Frame | Inboard | Outboard | |
|------------|---------|----------------|------------|
| | | Double Row | Duplex |
| STX | 6207 | 5306A / C3 | 7306 BECBM |
| MTX | 6309 | 5309A / C3 | 7309 BECBM |
| LTX | 6311 | not applicable | 7310 BECBM |
| XLT-X, X17 | 6313 | 5313A / C3 | 7313 BECBY |

**Table 12
3196 Shaft Runout Tolerances**

| | Sleeve Fit in. (mm) | Coupling Fit in. (mm) |
|-------------|------------------------|--------------------------|
| With Sleeve | .001 (.026) | .001 (.026) |
| Less Sleeve | .002 (.051) | .001 (.026) |

Note: Bearing type is based on SKF/MRC designation.

Assembly of Rotating Element and Bearing Frame

STX, MTX

NOTE: Make sure that threads are clean and apply thread sealant to pipe threads and fittings.

1. Install oil fill plug (113A), oil drain plug (408A), sight window (319), sight oiler plug (408J), 4 oil mist connection plugs (408H) or grease fittings (193) and relief plugs (113), and oil cooler inlet and outlet plugs (408L, 408M) in bearing frame (228). (Fig. 74)
2. Attach bearing frame foot (241) with bolts (370F). Hand tighten.

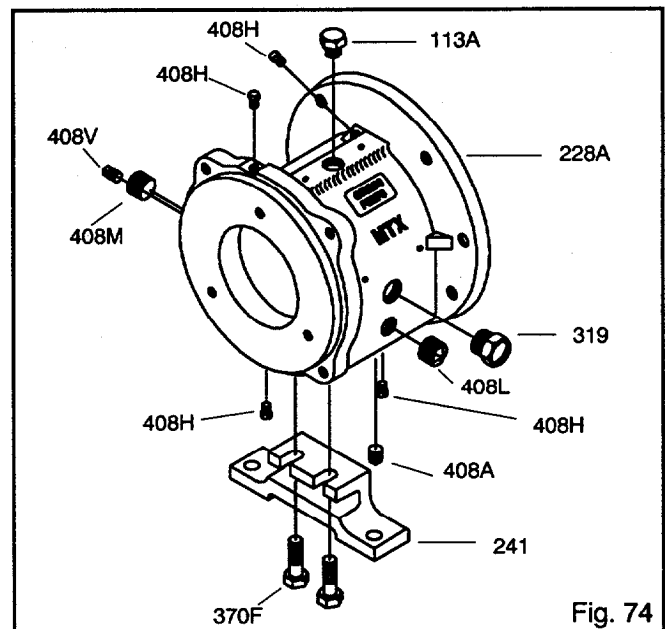

Fig. 74

3. Install outboard bearing (112A) on shaft (122) (Fig. 75).

NOTE: Regreaseable bearing has a single shield. The outboard bearing is installed with shield toward impeller.

NOTE: There are several methods used to install bearings. The recommended method is to use an induction heater that heats as well as demagnetizes the bearings.



WARNING

Wear insulated gloves when using a bearing heater. Bearings will get hot and can cause physical injury.

4. Place lockwasher (382) on shaft (122). Place tang of lockwasher in keyway of shaft.
5. Thread locknut (136) onto shaft (122). Tighten locknut until snug. Bend any tang of lockwasher into a slot of locknut.

NOTE: Tighten locknut if necessary to align the closest tab of lockwasher with slot on locknut.

6. Place bearing retaining ring (361A) over shaft (122), flat side facing bearing.
7. Install inboard bearing (168A) on shaft (122).

NOTE: Regreaseable bearing has a single shield. The inboard bearing is installed with shield away from impeller.

NOTE: There are several methods used to install bearings. The recommended method is to use an induction heater that heats as well as demagnetizes the bearings.



WARNING

Wear insulated gloves when using a bearing heater. Bearings will get hot and can cause physical injury.

NOTE: Coat internal surfaces of bearings with lubricant to be used in service.

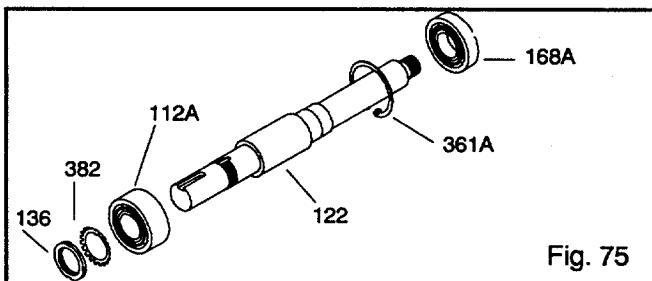

Fig. 75

8. Install new O-ring (496) (Fig. 76).
9. Coat outside of outboard bearing (112A) and bearing housing (134) bore with oil.
10. Install bearing housing (134) onto shaft/bearing assembly.

NOTE: Do not force assembly together.

11. Insert retaining ring (361A) into groove in housing (134) bore. Check shaft for free turning.

NOTE: The space between the ends of retaining ring should be located in the oil return groove so as not to obstruct oil flow.

12. Install outboard labyrinth oil seal (332A) into bearing housing (134). It is an O-ring fit. Position the labyrinth seal drain slots at the bottom (6 o'clock) position.

NOTE: Make sure the keyway edges are free of burrs.

NOTE: Cover the keyway lengthwise with a piece of electrical tape prior to installing the labyrinth seal. This will protect the O-rings.

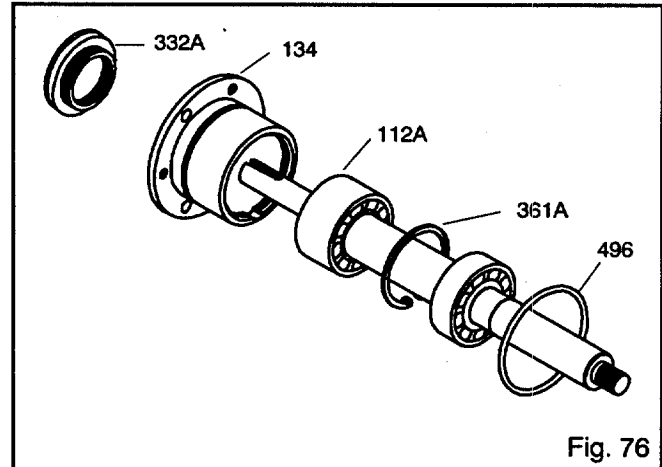
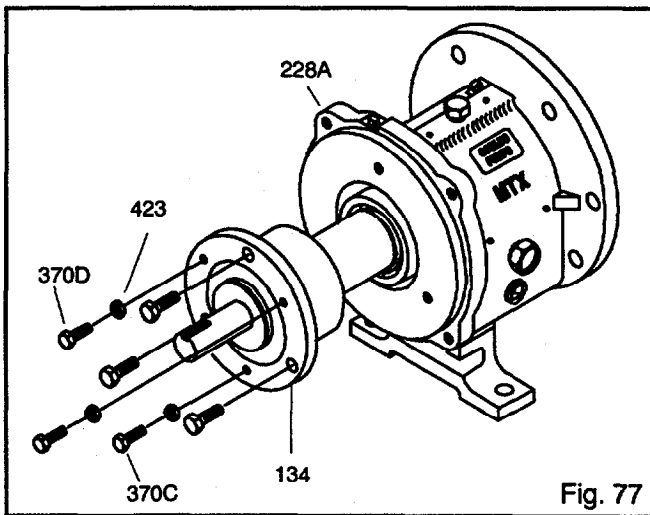

Fig. 76

13. Coat outside of bearing housing (134) with oil (Fig. 77).
14. Coat all internal surfaces of bearing frame (228A) with oil.
15. Install shaft assembly into frame (228A). Check shaft for free turning.
16. Install clamping bolts (370C) into bearing housing (134). Hand tighten.

17. Install jacking bolts (370D) with locking nuts (423) into housing (134). Hand tighten.



LTX

NOTE: Make sure that threads are clean and apply thread sealant to pipe threads and fittings.

1. Install the oil fill plug (113A), oil drain plug (408A), sight window (319), sight oiler plug (408J), 4 oil mist connection plugs (408H) or grease fittings (193) and grease relief plugs (113), and oil cooler inlet and outlet plugs (408L, 408M) in bearing frame (228) (Fig. 78).
2. Attach bearing frame foot (241) with bolts (370F). Hand tighten.

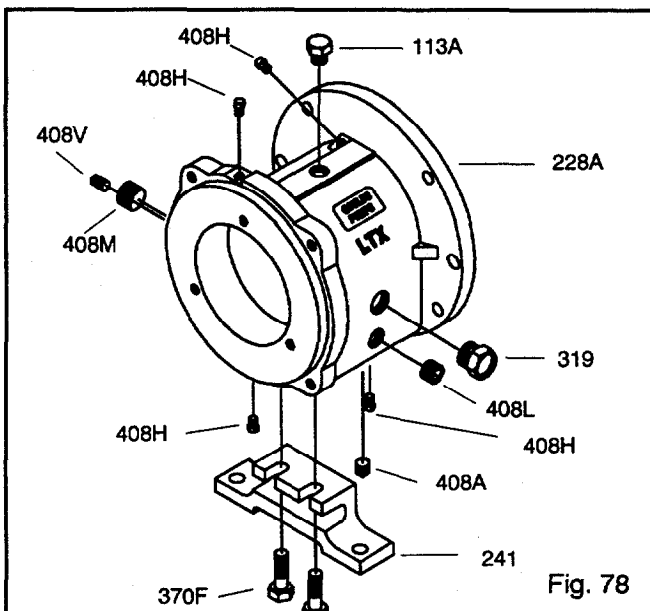

3. Install oil flinger (248A) on shaft (122) if removed (Fig. 79).

NOTE: The oil flinger is a press fit onto shaft. Use a driver of proper size to prevent damage to oil flinger.

4. Place bearing clamp ring (253B) over shaft (122). Note orientation.
5. Install outboard bearings (112A) on shaft (122).



CAUTION

The LTX uses duplex bearings mounted back to back. Make sure orientation of the bearings is correct.

NOTE: There are several methods used to install bearings. The recommended method is to use an induction heater that heats as well as demagnetizes the bearings.



WARNING

Wear insulated gloves when using a bearing heater. Bearings will get hot and can cause physical injury.

6. Place lockwasher (382) on shaft (122). Place tang of lockwasher in keyway of shaft.
7. Thread locknut (136) onto shaft (122). Tighten locknut until snug. Bend any tang of lockwasher (382) into a slot of locknut.

NOTE: Tighten locknut if necessary to align the closest tab of lockwasher with slot on locknut.

8. Install inboard bearing (168A) on shaft (122).

NOTE: Regreaseable bearing has a single shield. The inboard bearing is installed with shield away from impeller.

NOTE: There are several methods used to install bearings. The recommended method is to use an induction heater that heats as well as demagnetizes the bearings.



WARNING

Wear insulated gloves when using a bearing heater. Bearings will get hot and can cause physical injury.

NOTE: Coat internal surfaces of bearings with lubricant to be used in service.

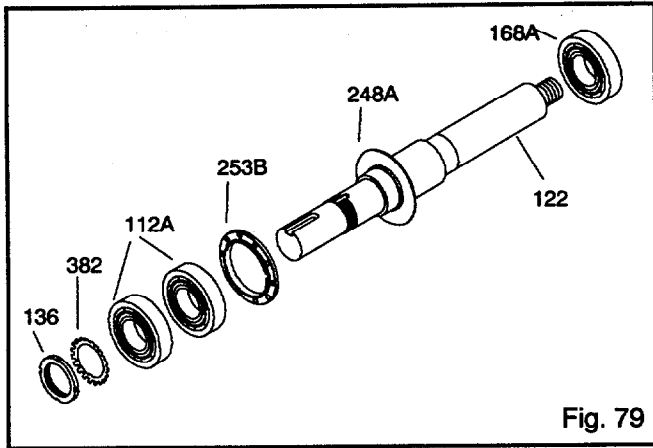

Fig. 79

9. Coat outside of outboard bearing (112A) and bearing housing (134A) bore with oil.
10. Install bearing housing (134) onto shaft/bearing assembly (Fig. 80).

NOTE: Do not force assembly together.

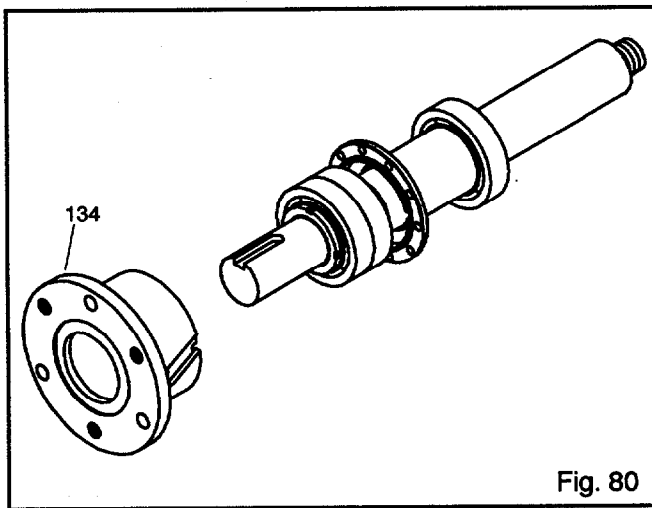

Fig. 80

11. Install clamp ring bolts (236A). Check shaft for free turning. Refer to Table 9 for bolt torque values (Fig. 81).



CAUTION

Tighten clamp ring bolts (236A) in a criss cross pattern.

12. Install new O-ring (496).
13. Install outboard labyrinth oil seal (332A) into bearing housing (134). It is an O-ring fit. Position the labyrinth seal drain slots at the bottom (6 o'clock) position.

NOTE: Make sure the keyway edges are free of burrs.

NOTE: Cover the keyway lengthwise with a piece of electrical tape prior to installing the labyrinth seal. This will protect the O-rings.

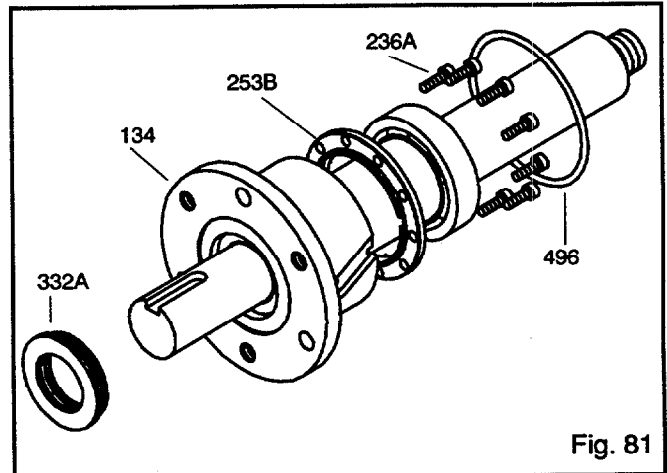

Fig. 81

14. Coat outside of bearing housing (134A) with oil.
15. Coat all internal surfaces of bearing frame (228) with oil.
16. Install shaft assembly into frame (228A). Check shaft for free turning.
17. Install clamping bolts (370C) into bearing housing (134A). Hand tighten.
18. Install jacking bolts (370D) with locking nuts (423) into housing (134A). Hand tighten.

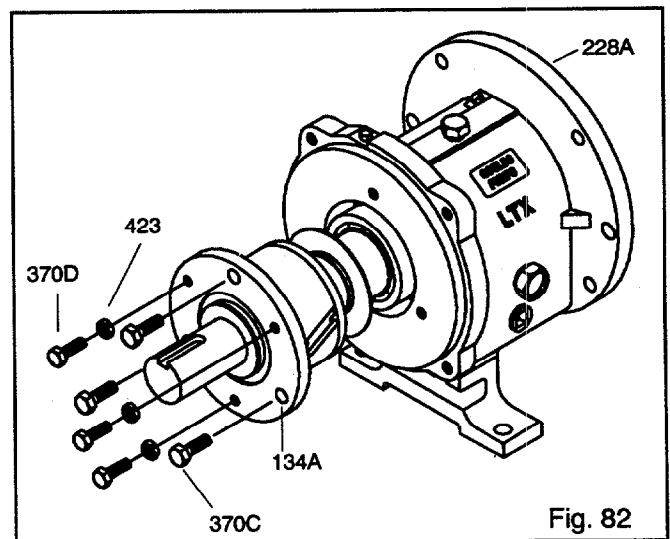
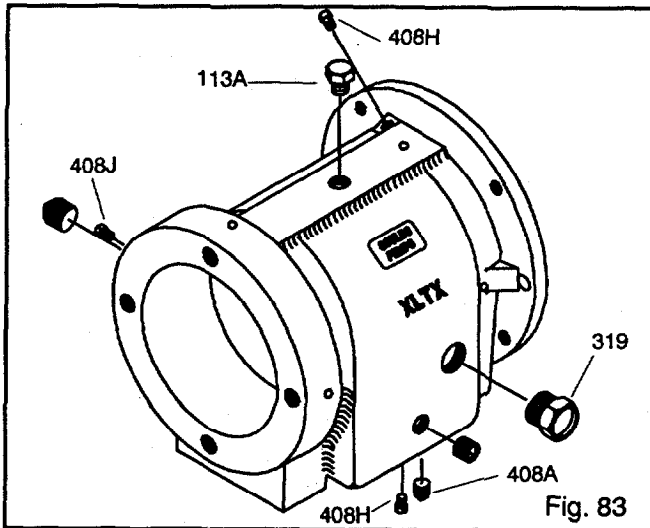

Fig. 82

XLT-X, X17

NOTE: Make sure that threads are clean and apply thread sealant to pipe threads and fittings.

1. Install oil fill plug (113A), oil drain plug (408A), sight glass (319), sight oiler plug (408J), 4 oil mist connection plugs (408H), or grease fittings (193) and grease relief plugs (113), and oil cooler inlet and outlet plugs (408L, 408M) in bearing frame (228A) (Fig. 83).



2. Install outboard bearing (112A) on shaft (122) (Fig. 84).

NOTE: Regreaseable bearing has a single shield. The outboard bearing is installed with shield toward impeller.

NOTE: There are several methods used to install bearings. The recommended method is to use an induction heater that heats as well as demagnetizes the bearings.



WARNING

Wear insulated gloves when using a bearing heater. Bearings will get hot and can cause physical injury.



WARNING

Shaft (122) may be heavy. Use care when handling.

3. Place lockwasher (382) on shaft (122). Place tang of lockwasher in keyway of shaft.
4. Thread locknut (136) onto shaft (122). Tighten locknut until snug. Bend any tang of lockwasher (382) into a slot of locknut.

NOTE: Tighten locknut if necessary to align the closest tab of lockwasher with slot on locknut.

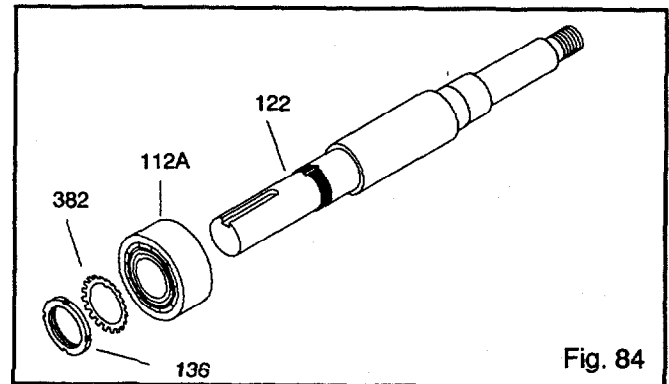

5. Coat outside of outboard bearing (112A) and bore of bearing housing (134) with oil.
6. Install bearing housing (134) onto shaft/bearing assembly (Fig. 85).

NOTE: Do not force assembly together.

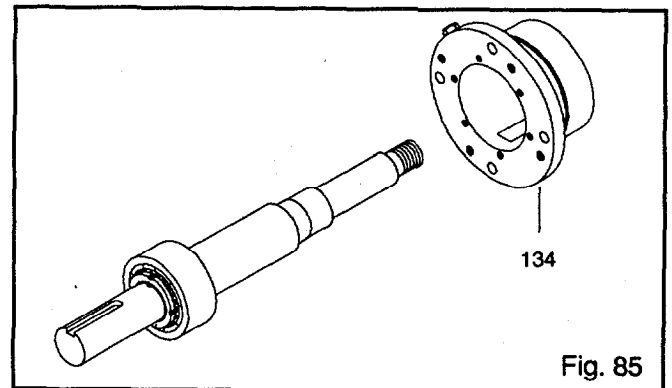

7. Install gasket (360C), end cover (109A), bolts (371C). Refer to Table 9 for bolt torque values. Check shaft for free turning.

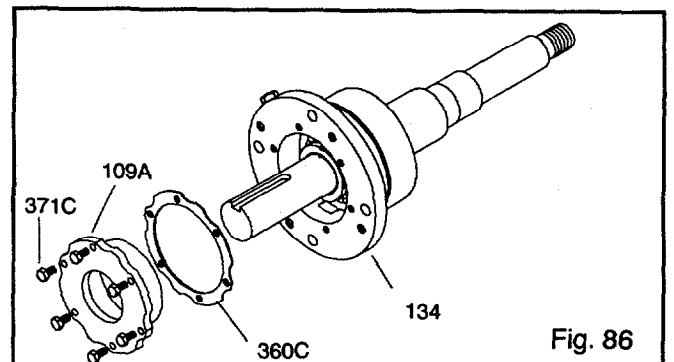

- Install inboard bearing (168A) on shaft (122) (Fig. 87).

NOTE: Regreaseable bearing has a single shield. The inboard bearing is installed with shield away from Impeller.

NOTE: There are several methods used to install bearings, The recommended method is to use an induction heater that heats as well as demagnetizes the bearings.



WARNING

Wear insulated gloves when using a bearing heater. Bearings will get hot and can cause physical injury.

NOTE: Coat internal surfaces of bearings with lubricant to be used in service.

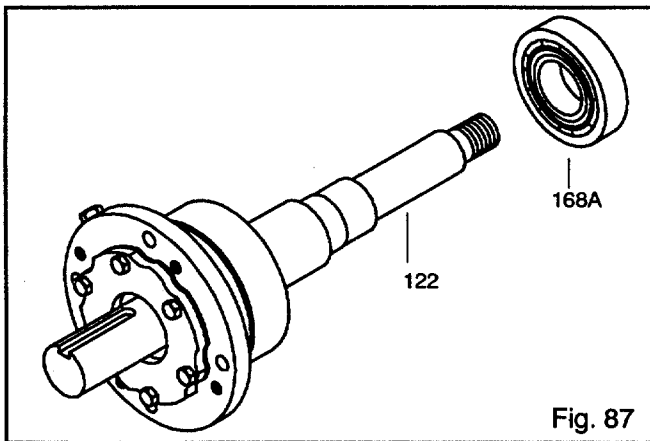

- Install new O-ring (496) (Fig. 88).
- Install outboard labyrinth oil seal (332A) into end cover (109A). It is an O-ring fit. Position the labyrinth seal drain slots at the bottom 6 o'clock position (Fig. 88).

NOTE: Make sure the keyway edges are free of burrs.

NOTE: Cover the keyway lengthwise with a piece of electrical tape prior to installing the labyrinth seal. This will protect the O-rings.

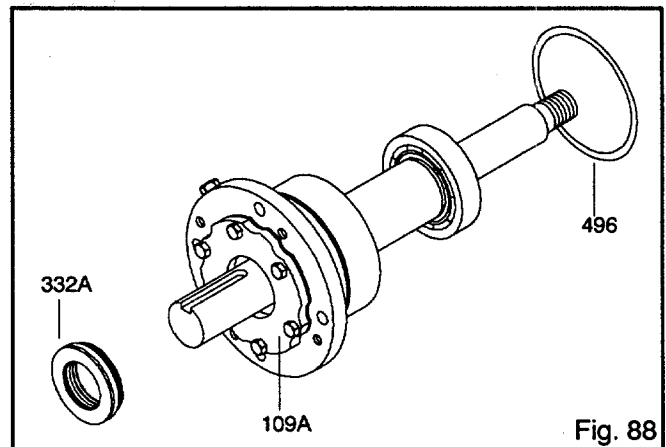

- Coat outside of bearing housing (134) with oil.
- Coat all internal surfaces of bearing frame (228A) with oil.
- Install shaft assembly into frame (228A). Check shaft for free turning (Fig. 89).
- Install clamping bolts (370C) into bearing housing (134). Hand tighten.
- Install jacking bolts (370D) with locking nuts (423) into housing (134). Hand tighten.
- Attach bearing frame foot (241) with bolts (370F). Hand tighten.

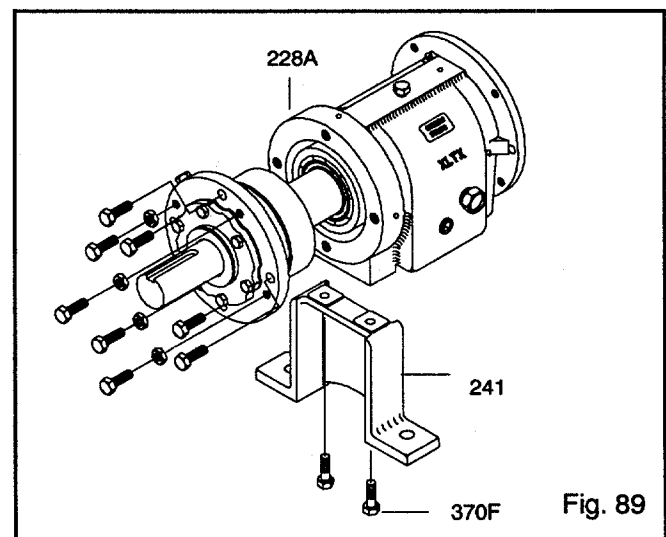

STX, MTX with Duplex Bearings

1. Install the oil fill plug (113A), oil drain plug (408A), sight window (319), sight oiler plug (408J), 4 oil mist connection plugs (408H), or grease fittings (193) and grease relief plugs (113), and oil cooler inlet and outlet plugs (408L, 408M) in bearing frame (228) (Fig. 90).
2. Attach bearing frame foot (241) with bolts (370F). Hand tighten (Fig. 90).

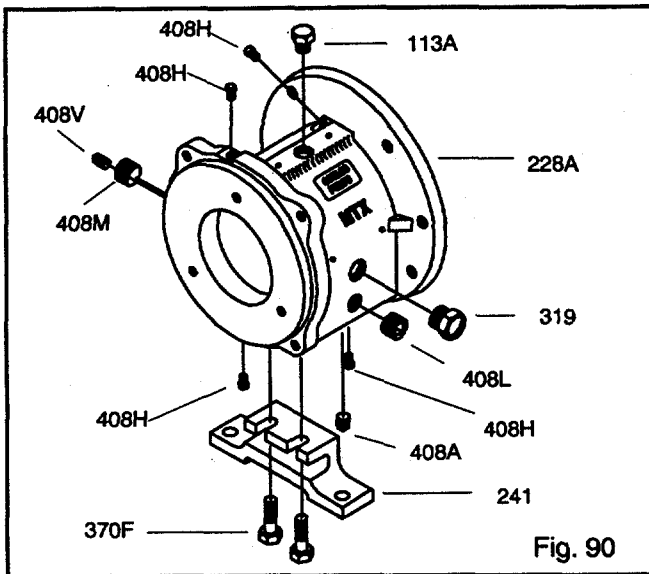

NOTE: There are several methods used to install bearings. The recommended method is to use an induction heater that heats as well as demagnetizes the bearings.



WARNING

Wear insulated gloves when using a bearing heater. Bearings will get hot and can cause physical injury.

3. Install outboard bearings (112A) on shaft (122).



CAUTION

Duplex bearings are mounted back to back. Make sure orientation of bearings are correct.

4. Place lockwasher (382) on shaft (122). Place tang of lockwasher in keyway of shaft (Fig. 91).
5. Thread locknut (136) onto shaft (122). Tighten locknut until snug. Bend any tang of lockwasher (382) into a slot of locknut.

NOTE: Tighten locknut if necessary to align the closest tab of lockwasher with slot on locknut.

6. Place bearing clamp ring (253B) over shaft (122). Note orientation.

7. Install inboard bearing (168A) on shaft (122).

NOTE: Regreaseable bearing has a single shield. The inboard bearing is installed with shield away from impeller.

NOTE: Coat internal surfaces of bearings with lubricant to be used in service.

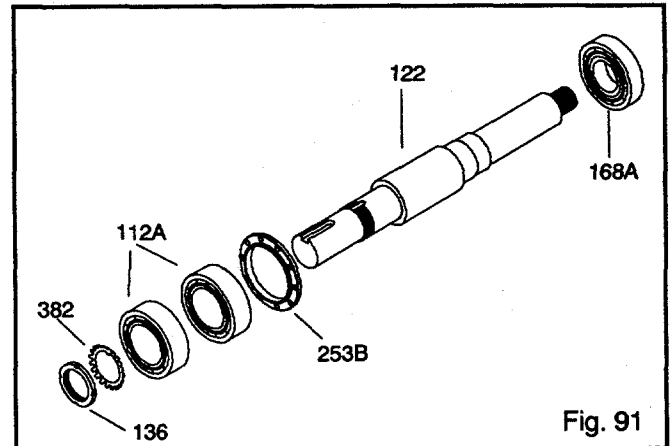

8. Coat outside of outboard bearing (112A) and bore of bearing housing (134) with oil.
9. Lower shaft/bearing assembly into bearing housing (134) (Fig. 92).

NOTE: Do not force assembly together.

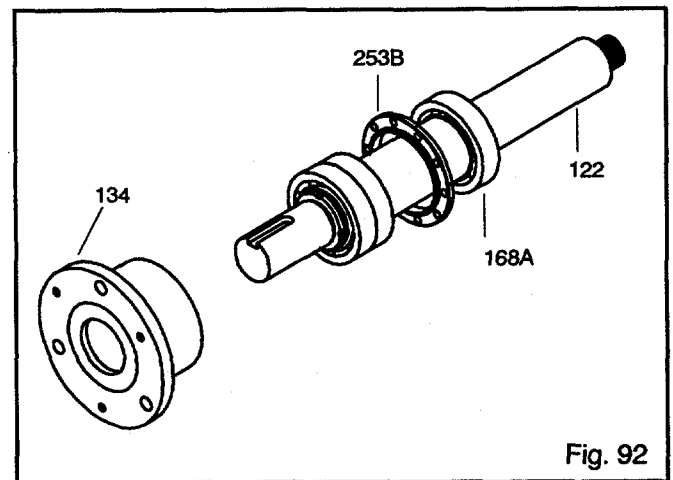

10. Install clamp ring (253B) with bolts (236A). Tighten bolts in a criss-cross pattern. Check shaft for free turning. Refer to Table 9 for bolt torque values (Fig. 93).
11. Install new O-ring (496).
12. Install outboard labyrinth oil seal (332A) into bearing housing (134). It is an O-ring fit. Position the labyrinth seal drain slots at the bottom 6 o'clock position (Fig. 93).

NOTE: Make sure the keyway edges are free of burrs.

NOTE: Cover the keyway lengthwise with a piece of electrical tape prior to installing the labyrinth seal. This will protect the O-rings.

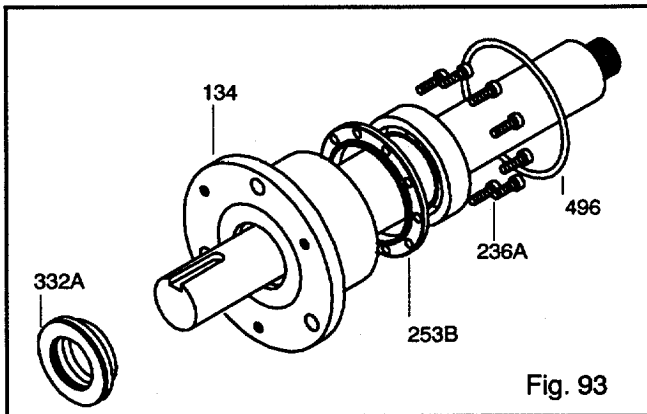

13. Coat outside of bearing housing (134) with oil.
14. Coat all internal surfaces of bearing frame (228A) with oil.
15. Install shaft assembly into frame (228A). Check shaft for free turning (Fig. 94).
16. Install clamping bolts (370C) into bearing housing (134A). Hand tighten.
17. Install jacking bolts (370D) with locking nuts (423) into housing (134A). Hand tighten.

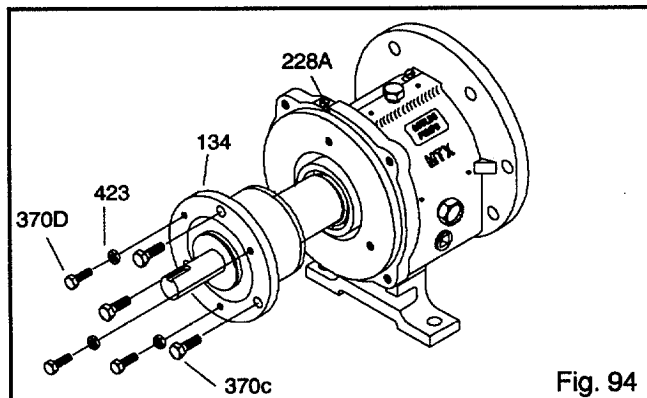

XLT-X, X17 with Duplex Bearings

NOTE: Make sure that threads are clean and apply thread sealant to pipe threads and fittings.

1. Install the oil fill plug (113A), oil drain plug (408A), sight window (319), sight oiler plug (408J), 4 oil mist connection plugs (408H), or grease fittings (193) and grease relief plugs (113), and oil cooler inlet and outlet plugs (408L, 408M) in bearing frame (228) (Fig. 95).

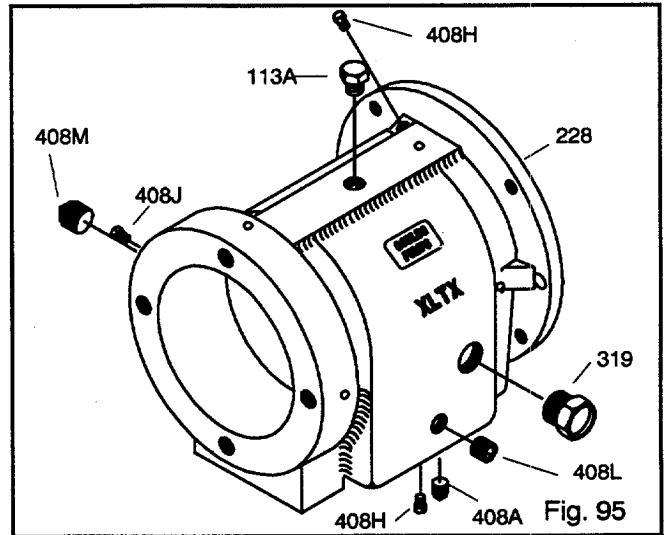

2. Install outboard bearings (112A) on shaft (122) (Fig. 96).

NOTE: There are several methods used to install bearings. The recommended method is to use an induction heater that heats as well as demagnetizes the bearings.



WARNING

Wear insulated gloves when using a bearing heater. Bearings will get hot and can cause physical injury



CAUTION

Duplex bearings are mounted back to back. Make sure orientation of bearings are correct.

3. Place lockwasher (382) on shaft (122). Place tang of lockwasher in keyway of shaft.
4. Thread locknut (136) onto shaft (122). Tighten locknut until snug. Bend any tang of lockwasher (382) into a slot of locknut.

NOTE: Tighten locknut if necessary to align the closest tab of lockwasher with slot on locknut.

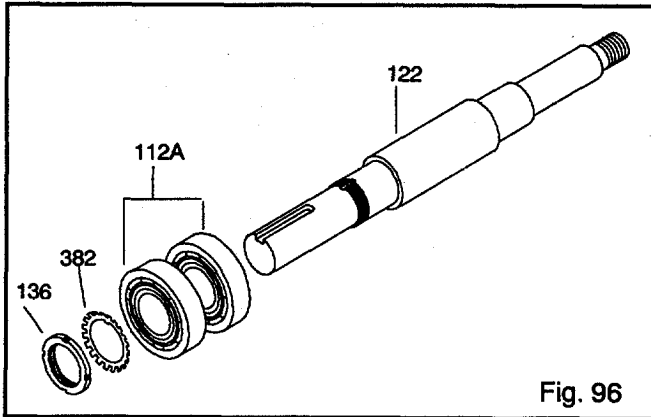

Fig. 96

5. Coat outside of outboard bearing (112A) and bore of bearing housing (134) with oil.
6. Install bearing housing (134) onto shaft/bearing assembly (Fig. 97).

NOTE: Do not force assembly together.

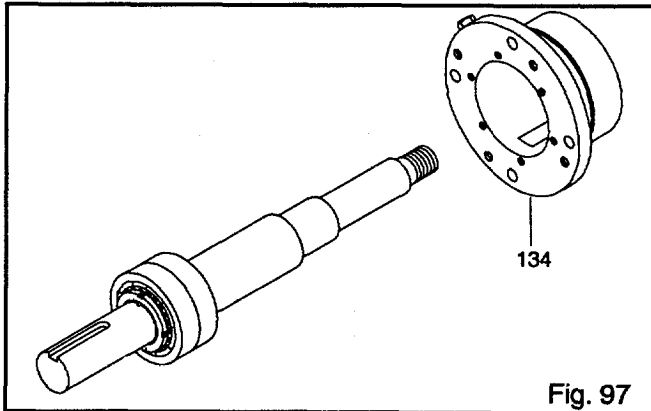

Fig. 97

7. Install gasket (360C), end cover (109A), and bolts (371C). Refer to Table 9 for bolt torque values. Check shaft for free turning (Fig. 98).

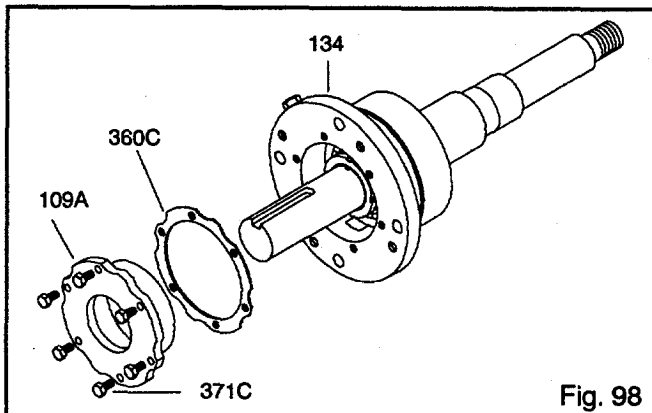

Fig. 98

8. Install inboard bearing (168A) on shaft (122) (Fig. 99).

NOTE: Regreaseable bearing has a single shield. The inboard bearing is installed with shield away from impeller.

NOTE: There are several methods used to install bearings, The recommended method is to use an induction heater that heats as well as demagnetizes the bearings.

WARNING

Wear insulated gloves when using a bearing heater. Bearings will get hot and can cause physical injury.

NOTE: Coat internal surfaces of bearings with lubricant to be used in service.

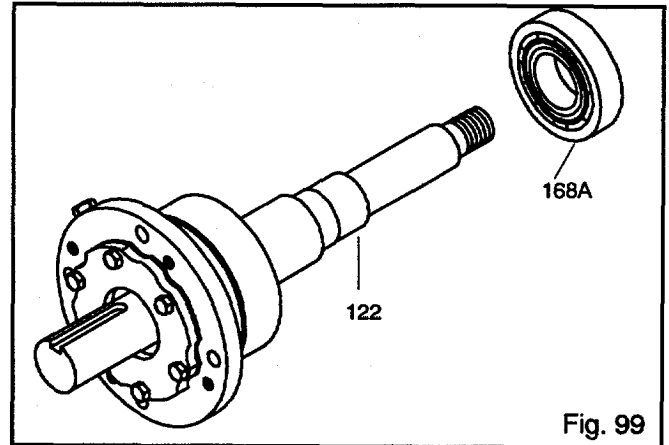

Fig. 99

9. Install new O-ring (496) (Fig. 100).
10. Install outboard labyrinth oil seal (332A) into end cover (109A). It is an O-ring fit. Position the labyrinth seal drain slots at the bottom 6 o'clock position.

NOTE: Make sure the keyway edges are free of burrs.

NOTE: Cover the keyway lengthwise with a piece of electrical tape prior to installing the labyrinth seal. This will protect the O-rings.

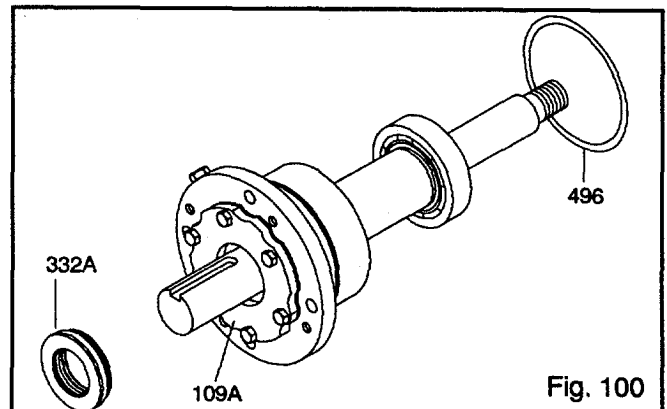
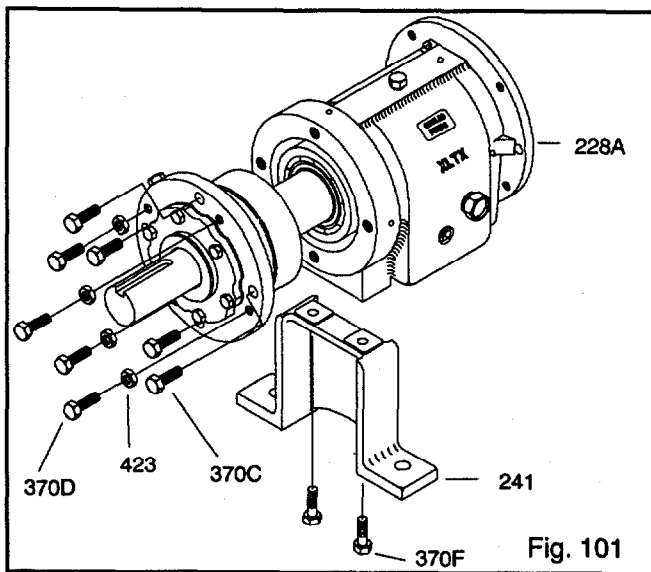

Fig. 100

11. Coat outside of bearing housing (134) with oil.

12. Coat all internal surfaces of bearing frame (228A) with oil.
13. Install shaft assembly into frame (228A). Check shaft for free turning (Fig. 101).
14. Install clamping bolts (370C) into bearing housing (134). Hand tighten.
15. Install jacking bolts (370D) with locking nuts (423) into housing (134). Hand tighten.
16. Attach bearing frame foot (241) with bolts (370F). Hand tighten.



ALL MODELS

1. Support frame assembly in horizontal position.
2. Check shaft end play. Move shaft forward then backward by hand, noting indicator movement. If total indicator reading is greater than Table 10, page 51, values, disassemble and determine cause (Fig. 102).

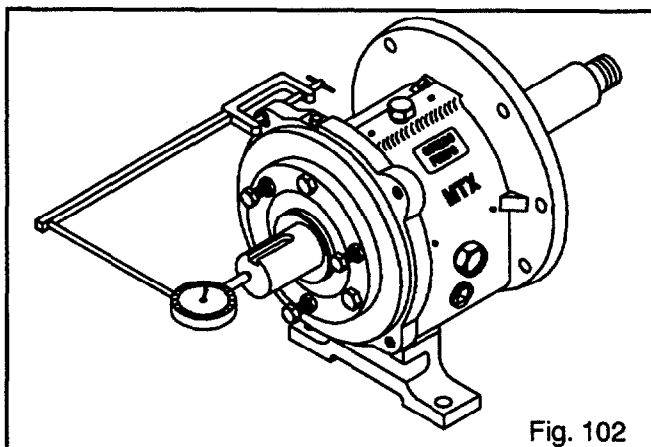

3. Check shaft/sleeve runout. Put on shaft sleeve (126) if used, and thread on impeller, hand tight. Rotate shaft 360 degrees. If total indicator reading is greater than .002 in., disassemble and determine cause. Remove impeller and shaft sleeve (Fig. 103).

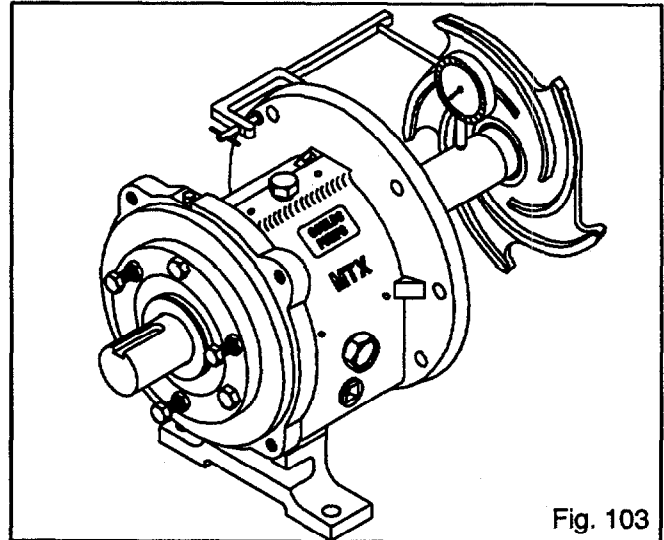

4. Check frame face run out. Rotate shaft so indicator rides along the fit for 360 degrees. If total indicator reading is greater than 0.001 in. (.025 mm) disassemble and determine cause (Fig. 104).

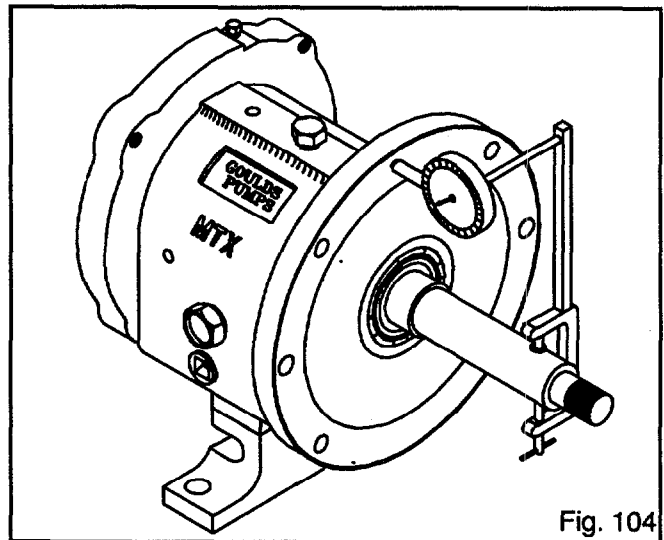

5. Place manila gasket (360D) on frame (228) (Fig. 105).

NOTE: The gasket is designed to fit one way only. The dowel pins (469B) may be started in their holes to hold the gasket in place.

6. Install frame adapter (108), onto frame assembly. Align bolt holes and dowel locations with those on frame (Fig. 105).
7. Install dowel pins (469B), and bolts (370B). Tighten bolts to Table 9, page 51, torque specifications, in a criss-cross pattern.

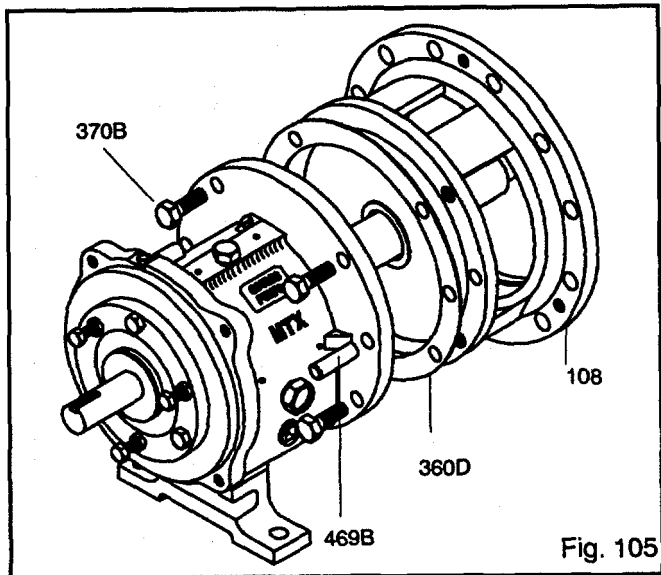

8. Check adapter fits. Rotate shaft through 360 degrees. If total indicator reading is greater than .005 in. (.13 mm), determine the cause and correct before proceeding (Fig. 106).

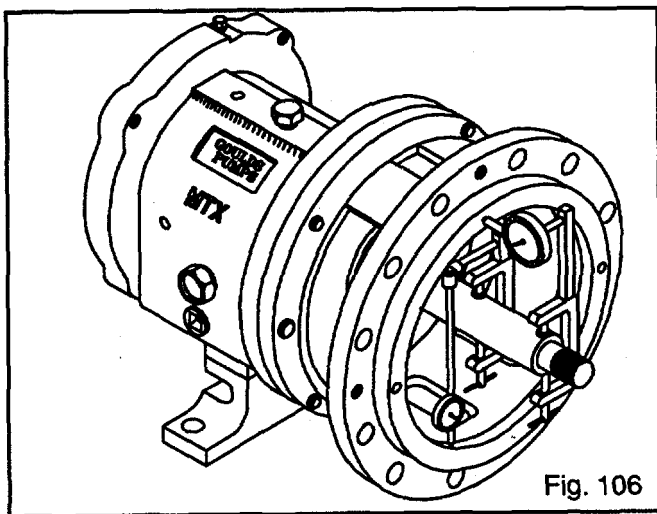

9. Install inboard labyrinth oil seal (333A) into adapter (108) / bearing frame (228). It is an O-ring fit. Position the labyrinth seal drain slots at the bottom (6 o'clock) position. (Fig. 107A, 107B)

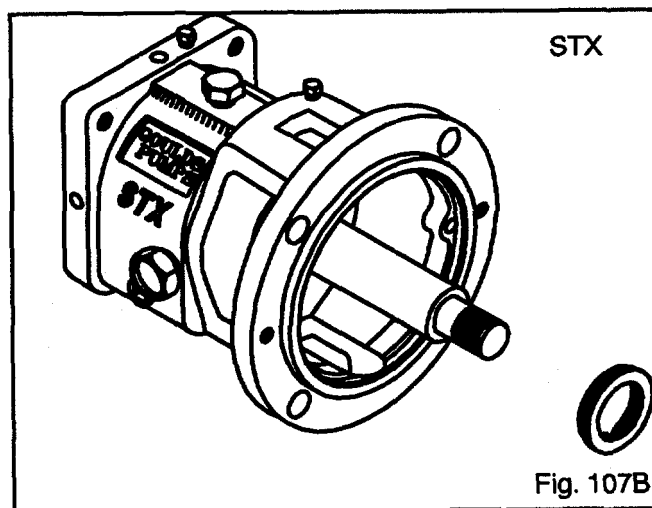
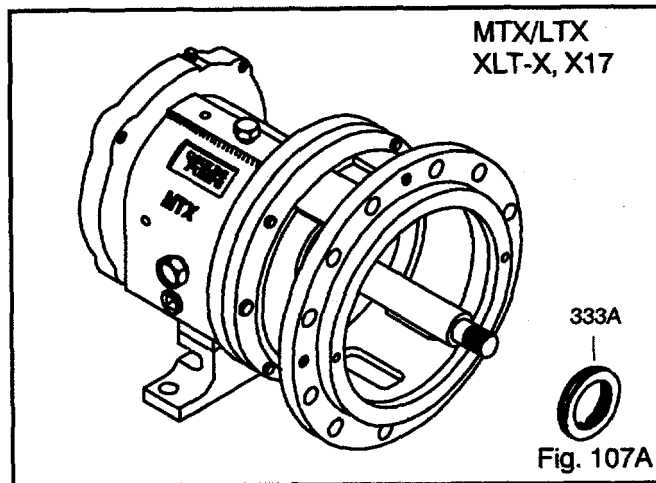

Pumps With Mechanical Seals:

1. Install seal chamber cover (184) with nuts (370H).

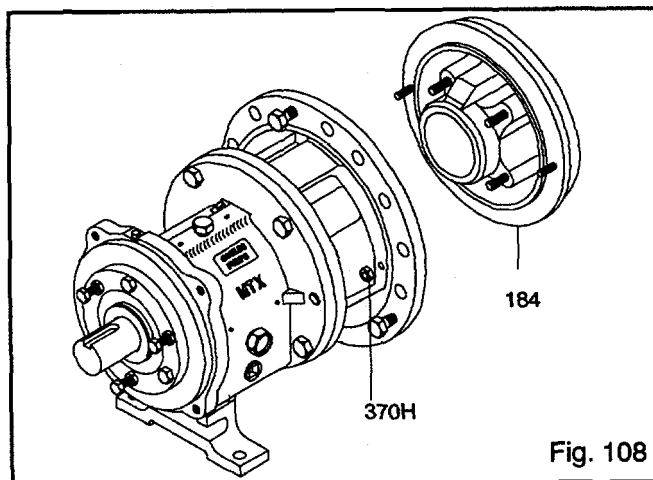

2. Check seal chamber cover run-out. Rotate indicator through 360 degrees. If total indicator reading is greater than 0.005 in. (.13 mm), determine cause and correct before proceeding (Fig. 109).

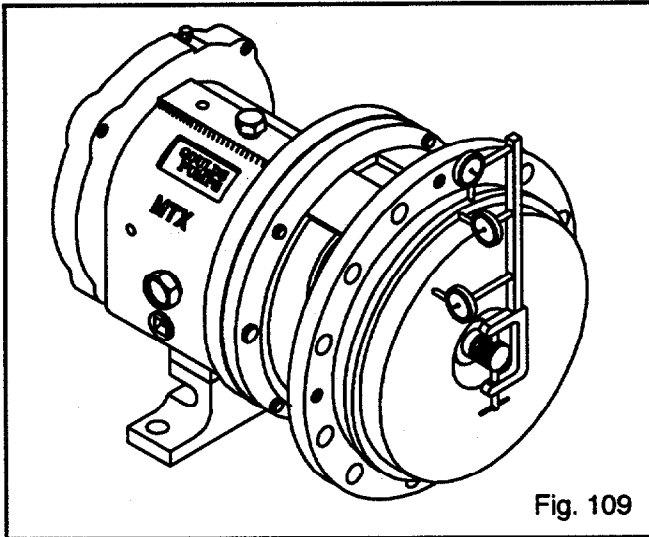

Fig. 109

3. Install shaft sleeve (126) if used (Fig. 110).

NOTE: Make sure sleeve is fully seated.



WARNING

Wear a heavy set of work gloves when handling impeller (101) as sharp edges may cause physical injury.

4. **STX, MTX, LTX** - Install impeller (101) with O-ring (412A).

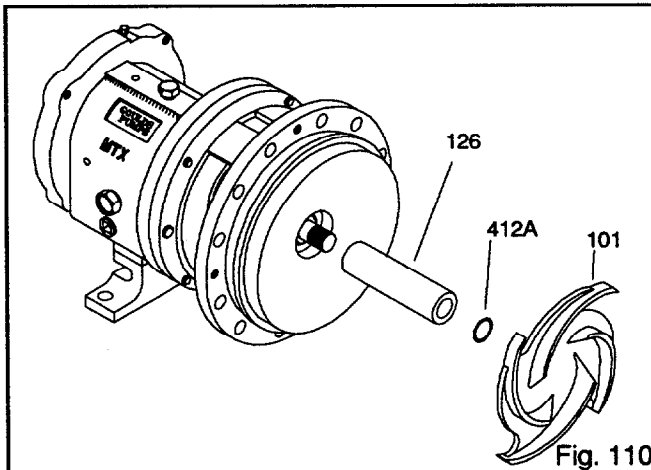

Fig. 110

- 4a. **XLT-X & X17** - Install impeller (101) with O-ring (412A). Install new teflon washer (428D) on plug (458Y) and install in nose of impeller.

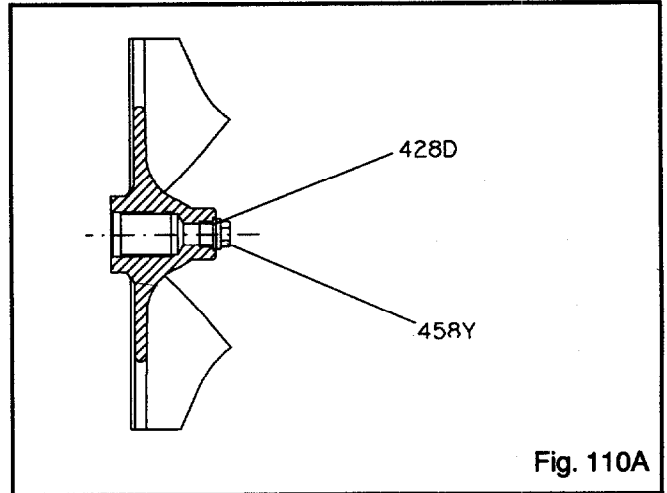

Fig. 110A

5. Put shaft wrench and coupling key on shaft. When impeller (101) makes firm contact with sleeve (126), raise shaft wrench (counterclockwise, viewed from impeller end of shaft) off bench and slam it down (clockwise, viewed from impeller end of shaft). A few sharp raps will tighten impeller (101) properly (Fig. 111).

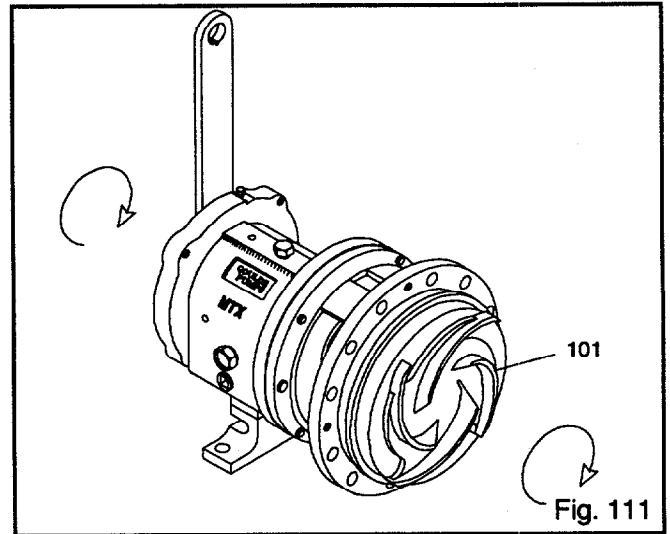

Fig. 111

- Loosen clamp bolts (370C), and jacking bolts (370D). Measure gap between impeller (101) and seal chamber/stuffing box cover (184) with a feeler gauge. When 0.030 in. clearance is reached, tighten clamp bolts (370C), jacking bolts (370D), and locking nuts (423) (Fig. 112)

NOTE: This approximates the impeller position when set at 0.015 in. (.38 mm) from casing. Final impeller adjustment must be made after installation into casing.

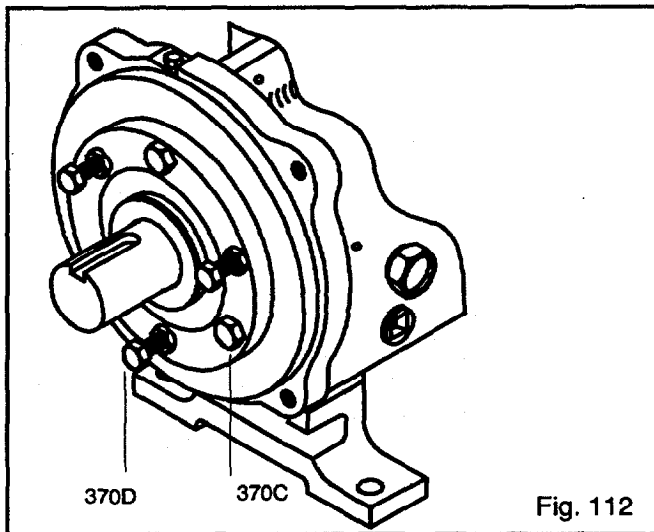

Fig. 112

- Check impeller (101) runout. Check vane tip to vane tip. If total indicator reading is greater than 0.005 in. (.13 mm), determine cause and correct before proceeding (Fig. 113).

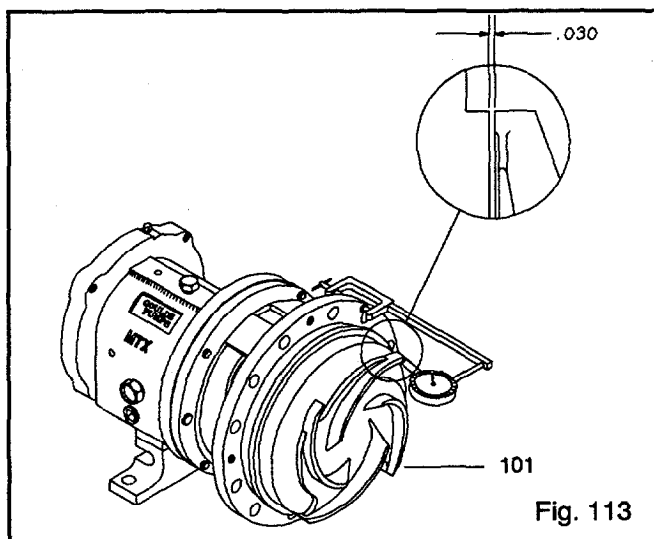

Fig. 113

- Blue the shaft sleeve (126) or shaft (122) if no sleeve is used. Scribe a mark at gland gasket face of seal chamber/stuffing box cover (184). This will be the datum for installation of mechanical seal (Fig. 114).

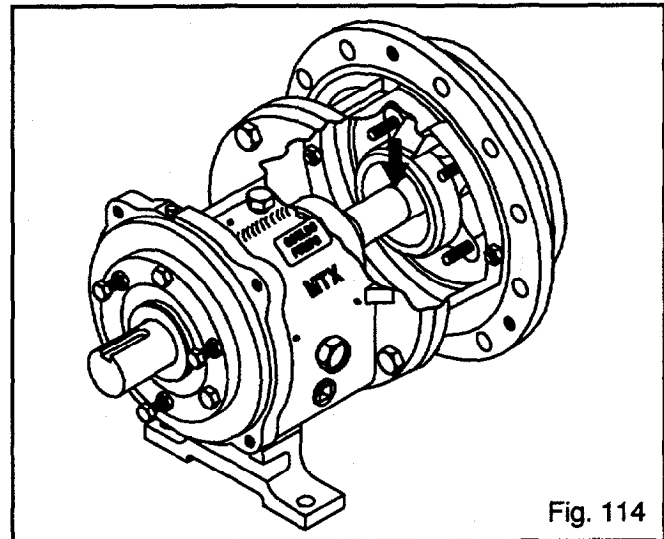

Fig. 114

- Remove the impeller (101), and shaft sleeve (126) if used.

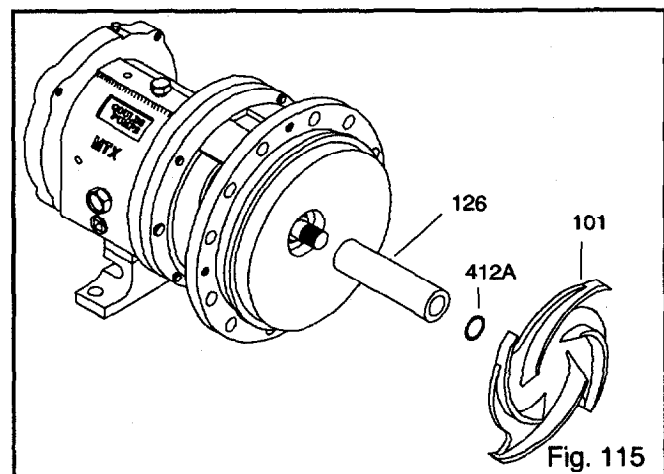

Fig. 115

10. Remove seal chamber cover (184).

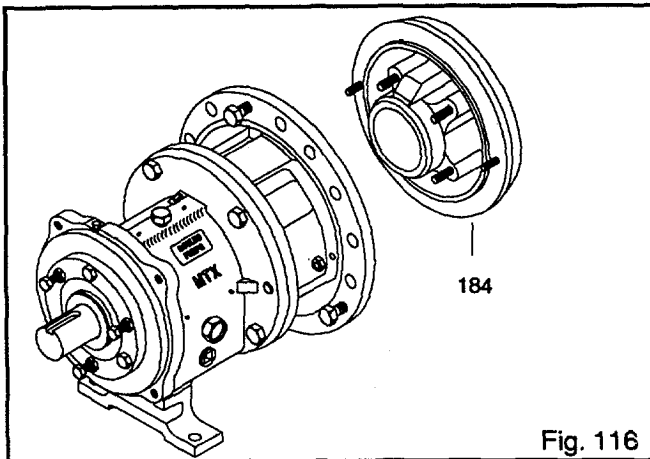

Fig. 116

11. Install stationary seat into gland (107) per seal manufacturer's instructions.
12. Slide gland (107) with stationary seat over shaft, up to adapter face.
13. Install mechanical seal on shaft (122) or shaft sleeve (126) per seal manufacturer's instructions. Install shaft sleeve (126) if used (with seal).

NOTE: Anti-galling compound can be applied to the sleeve bore to aid in disassembly.

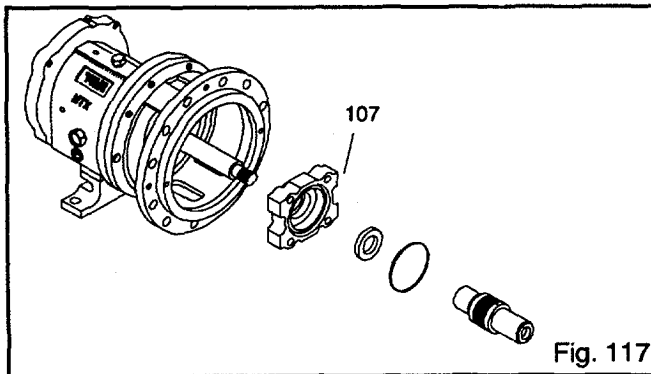

Fig. 117

14. Install seal chamber cover (184) with nuts (370H).

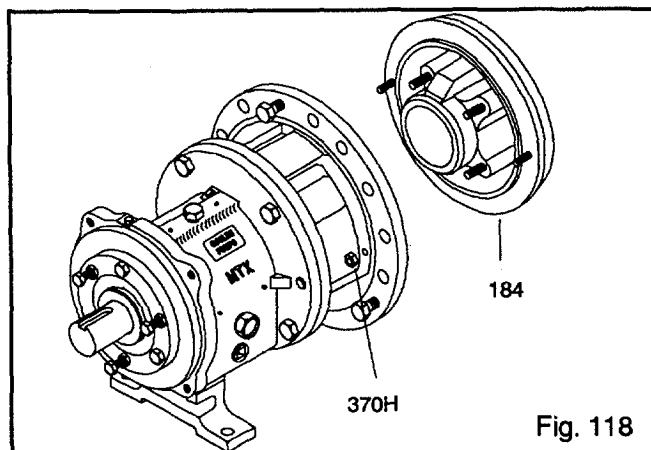

Fig. 118

WARNING

Wear a heavy set of work gloves when handling impeller (101) as sharp edges may cause physical injury.

15. Install impeller (101) with new O-ring (412A). Put shaft wrench and coupling key on shaft. When impeller (101) makes firm contact with sleeve (126), raise shaft wrench (counterclockwise when viewed from impeller end of shaft) off bench and slam it down (clockwise when viewed from impeller end of shaft). A few sharp raps will tighten impeller (101) properly.

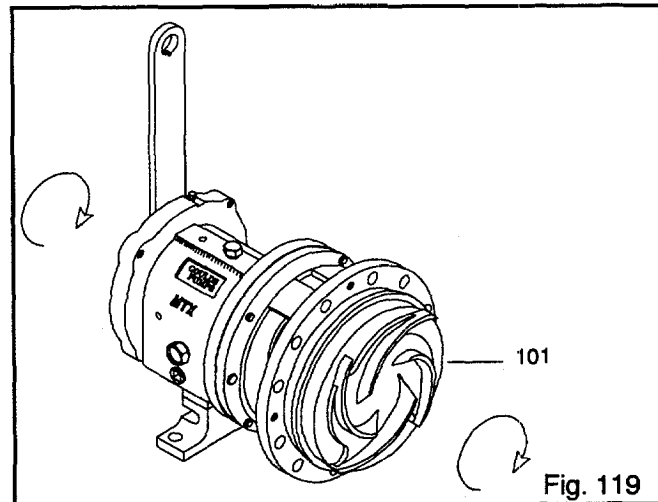

Fig. 119

6

16. Install gland (107) with nuts (355).

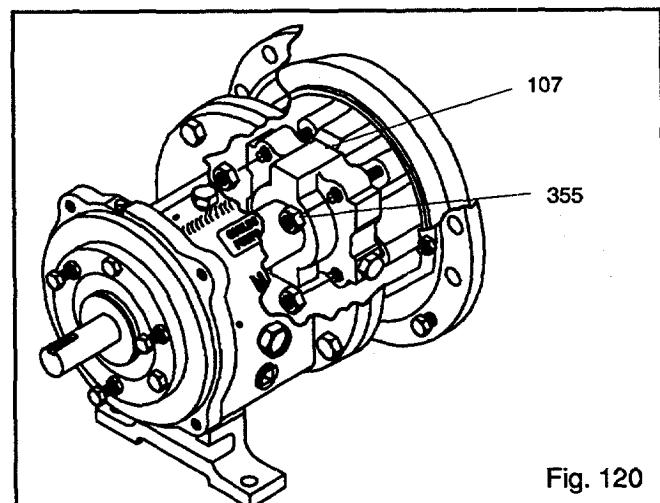
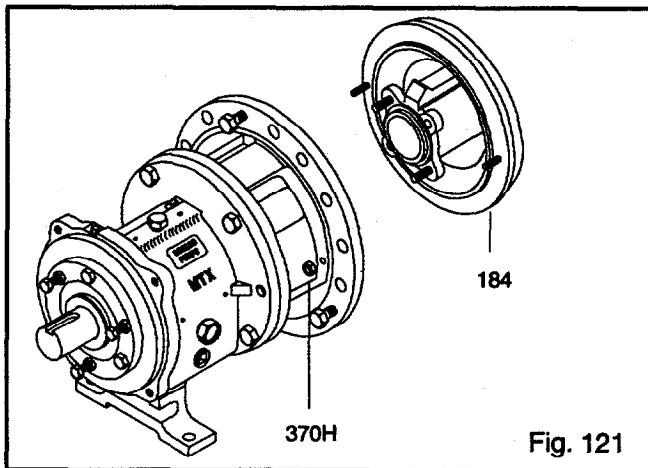

Fig. 120

Pumps With Packing:

1. Install stuffing box cover (184) with nuts (370H).



2. Check stuffing box cover run-out. Rotate indicator through 360 degrees. Total indicator reading greater than 0.005 in. (.13 mm) indicates a problem (Fig. 122).

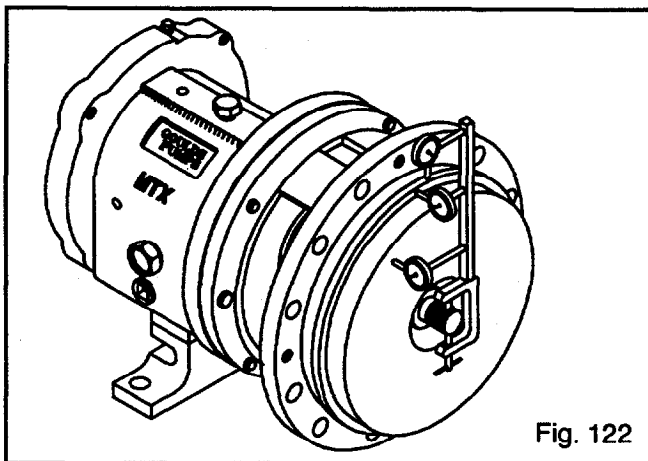

3. Install shaft sleeve (126) (Fig. 123).

NOTE: Anti-galling compound, can be applied to the sleeve bore to aid in disassembly.

NOTE: Make sure sleeve is fully seated.



WARNING

Wear a heavy set of work gloves when handling impeller (101) as sharp edges may cause injury.

4. Install impeller (101) with O-ring (412A). Put shaft wrench and coupling key on shaft. When impeller (101) makes firm contact with sleeve (126), raise shaft wrench (counterclockwise when viewed from impeller end of shaft) off bench and slam it down (clockwise when viewed from impeller end of shaft). A few sharp raps will tighten impeller properly (Fig. 124).

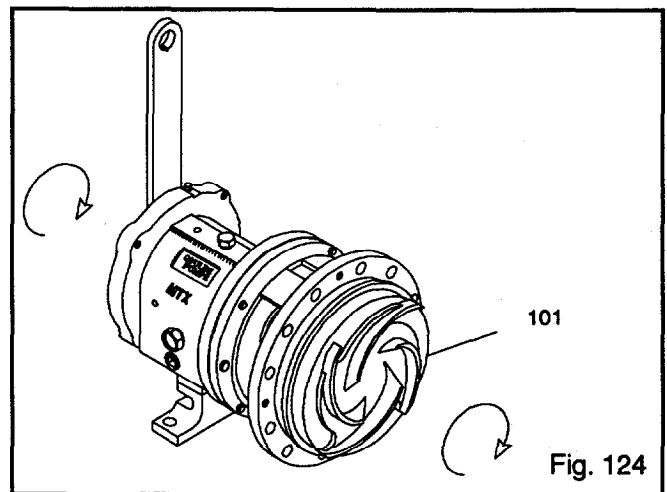
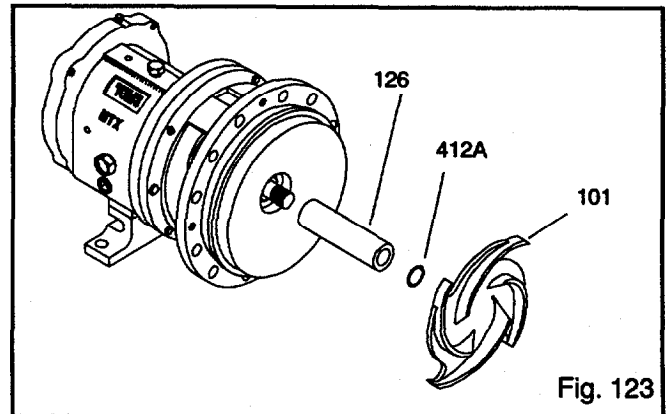

5. Loosen clamp bolts (370C), and jacking bolts (370D) (Fig. 124). Measure gap between impeller (101) and seal chamber/stuffing box cover (184) with a feeler gauge. When 0.030 in. (.76 mm) clearance is reached, tighten clamp bolts (370C), jacking bolts (370D), and locking nuts (423) (Fig. 125).

NOTE: This approximates the impeller position when set at 0.015 in. (.38 mm) from casing.

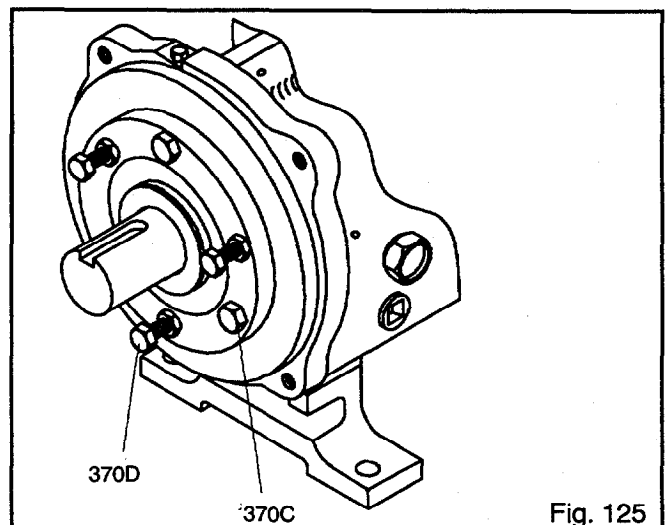

6. Check impeller runout. Check vane tip to vane tip. Total indicator reading greater than 0.005 in. (.13 mm) indicates a problem (Fig. 126).

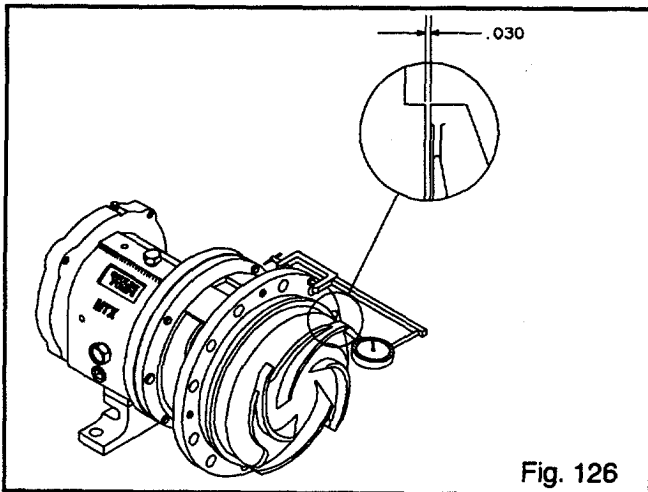

Fig. 126

7. Install packing and gland according to Section 4, Operation.

Pumps With Dynamic Seals:

1. Place backplate (444) flat side down on the bench (Fig. 127).
2. Place repeller (262) in backplate (444), sleeve side up.
3. Place teflon gasket (264) on backplate (444), lining up holes.
4. Place stuffing box cover (184) on backplate (444), lining up holes.
5. Install four (4) socket head cap screws (265), tighten securely.
6. Install new sealing element into gland.
7. Install gasket (360Q) and gland (107) on stuffing box cover (184). Install nuts (355).

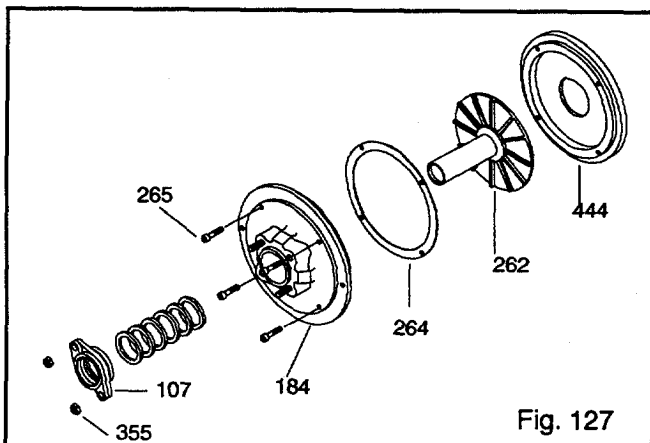

Fig. 127

8. Install dynamic seal assembly. Install nuts (370H) (Fig. 128).

NOTE: Anti-galling compound, can be applied to the sleeve bore to aid in disassembly.

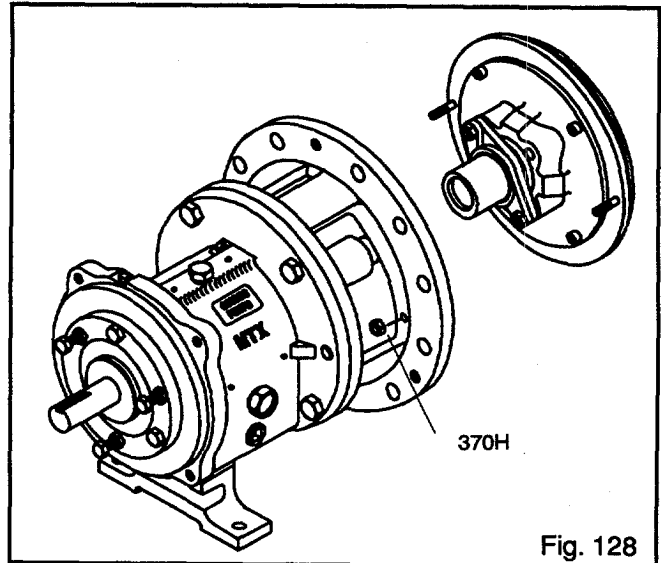

Fig. 128

9. Check stuffing box cover run-out. Rotate indicator through all 360 degrees. Total indicator reading greater than 0.005 in. indicates a problem (Fig. 129).

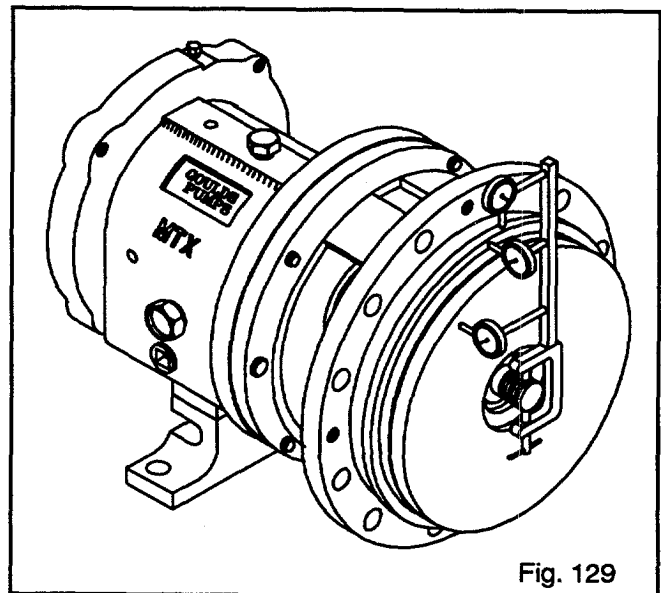

Fig. 129

ALL MODELS STX, MTX, LTX, XLT-X, X17

Reinstall Back Pull-Out Assembly



WARNING

Back pull-out assembly weighs more than 50 lbs. Do not handle unassisted as physical injury may occur.

1. Clean casing fit and install casing gasket (351) in place on seal chamber/stuffing box cover.
2. Loosen clamping bolts (370C) and jacking bolts (370D) on bearing housing (Fig. 130).

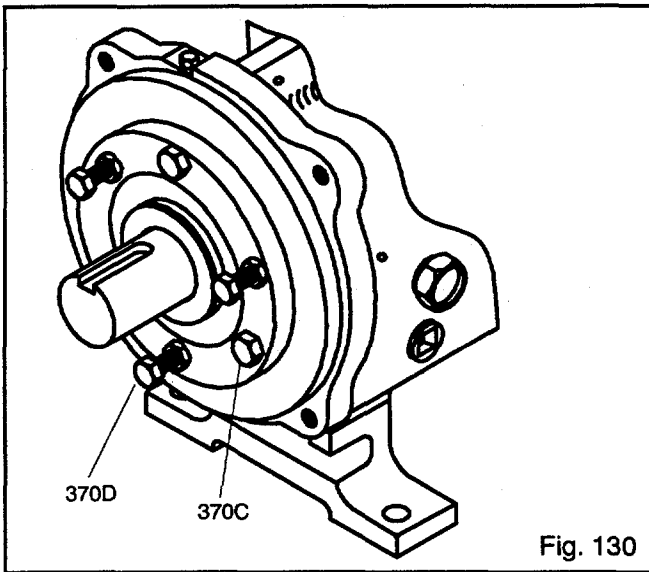

Fig. 130

3. Install back pull-out assembly in casing (Fig. 131).

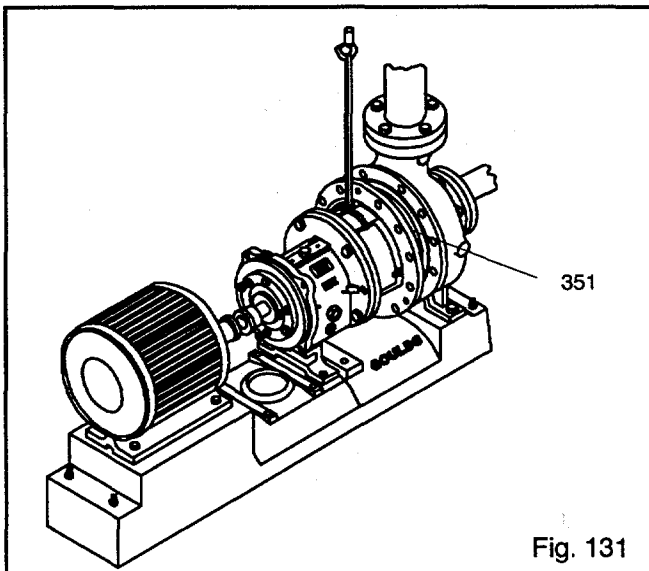

Fig. 131

4. Install casing bolts (370), finger tight. Casing bolts (370) may be coated with anti-galling compound to aid disassembly. Tighten the casing bolts per Table 9 torque values, page 51. Install casing jack screws (418), snug tight (Fig. 132).



CAUTION

Do not overtighten casing jack screws (418).

- 4a. Replace shims under frame foot and tighten frame foot to bedplate. To insure that the proper shim is used, a dial indicator should be mounted to measure distance between top of frame and bedplate. This distance should not change as frame foot bolting is tightened.

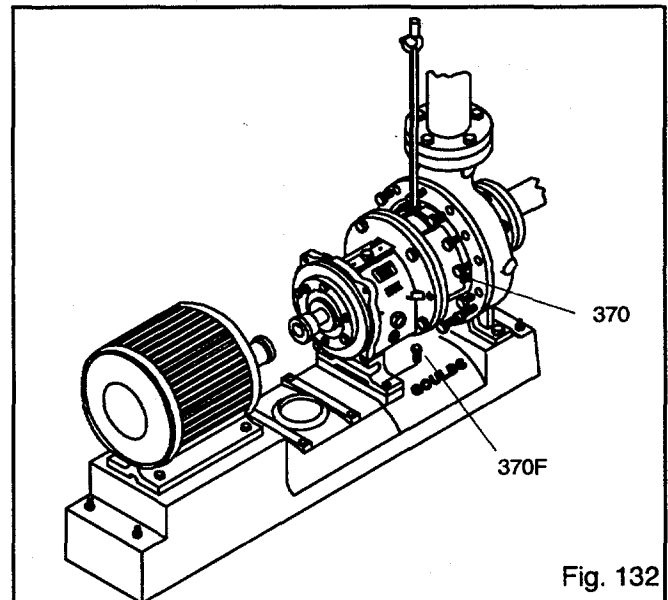

Fig. 132

5. Check total travel of impeller in casing. With new parts acceptable range is 0.030 in. (.76 mm). to 0.065 in. (1.65 mm). If outside this range improper parts or installation, or too much pipe strain is present. Determine cause and correct.
6. Adjust impeller clearance according to procedure outlined in Section 5, Preventive Maintenance.
7. Replace auxiliary piping at this time.
8. Fill pump with proper lubricant. Refer to Section 5, Preventive Maintenance for requirements.

POST ASSEMBLY CHECKS

After completion of these operations check whether it is possible to rotate shaft easily by hand. If all is proper, continue with pump start-up

| Assembly Troubleshooting | |
|---|---|
| Symptom | Cause |
| Excessive shaft end play. | Bearing internal clearance too great. Replace bearings with correct type. Snap ring loose in bearing housing groove. Reseat. |
| Excessive shaft/sleeve runout. | Sleeve worn. Replace Shaft bent. Replace. |
| Excessive bearing frame flange runout. | Shaft bent. Replace. Bearing frame flange distorted. Replace. |
| Excessive frame adapter runout. | Corrosion. Replace. Adapter to frame gasket not seated properly. Reseat. |
| Excessive seal chamber/stuffing box cover runout. | Seal chamber/stuffing box cover not properly seated in frame adapter. Corrosion or wear. Replace. |
| Excessive impeller vane tip runout. | Bent vane(s). Replace impeller. |

PARTS LIST WITH MATERIALS OF CONSTRUCTION

| Item | Qty per pump | Part Name | All D.I. | D.I. w/ 316SS Impeller | All 316SS | All CD4MC | All Alloy 20 | All 317SS | All Monel | All Nickel | All HastC | All Hast B | All Titanium |
|------|--------------|--------------------------------|----------|------------------------|-----------|-----------|--------------|-----------|-----------|------------|-----------|------------|-----------------|
| 100 | 1 | Casing | 1012 | 1012 | 1203 | 1216 | 1204 | 1209 | 1119 | 1601 | 1215 | 1217 | 1220 |
| 101 | 1 | Impeller | 1013 | 1203 | 1203 | 1216 | 1204 | 1209 | 1119 | 1601 | 1215 | 1217 | 1220 |
| 105 | 1 | Lantern Ring | | | | | | | | | | | |
| 106 | 1 Set | S.B. Packing | | | | | | | | | | | |
| 107 | 1 | Gland—Packed Box | | 1203 | | 1204 | | 1209 | 1119 | 1601 | 1215 | 1217 | 1220 |
| 108 | 1 | Frame Adapter | | | | | | 1013 | | | | | |
| 109C | 1 | Outboard Bearing End Cover | | | | | | | | | | | |
| 112 | 1 | Outboard Bearing | | | | | | | | | | | |
| 113 | 2 | Plug—Grease Relief | | | | | | | | | | | |
| 113A | 1 | Plug—Oil Fill | | | | | | | | | | | |
| 122 | 1 | Shaft—Less Sleeve | ▲ | | 2229 | | 2230 | 2232 | 2229 | 2229 | 2229 | 2229 | 2229 |
| 122 | 1 | Shaft—With Sleeve | | | 2238 | | | 2232 | 2229 | 2229 | 2229 | 2229 | 2229 |
| 126 | 1 | Shaft Sleeve | | 2229 | | 2230 | | 2232 | 2150 | 2155 | 2248 | 2247 | 2156 |
| 134 | 1 | Bearing Housing | | | | | | | | | | | |
| 136 | 1 | Bearing Locknut | | | | | | | | | | | |
| 168A | 1 | Inboard Bearing | | | | | | | | | | | |
| 184 | 1 | Seal Chamber/S.B. Cover | 1012 | 1012 | 1203 | 1216 | 1204 | 1209 | 1119 | 1601 | 1215 | 1217 | 1220 |
| 193 | 2 | Grease Fitting | | | | | | | | | | | |
| 228 | 1 | Bearing Frame | | | | | | | | | | | |
| 236A | 10 | Cap Screw—Brg Clamp Ring | | | | | | | | | | | |
| 241 | 1 | Frame Foot | | | | | | | | | | | |
| 248A | 1 | Oil Thrower | | | | | | | | | | | |
| 250 | 1 | Gland—Mech Seal | | | | | | | | | | | |
| 253B | 1 | Brg Clamp Ring | | | | | | | | | | | |
| 319 | 1 | Sight Glass | | | | | | | | | | | |
| 332A | 1 | Outboard Laby Seal w/O-rings | | | | | | | | | | | |
| 333A | 1 | Inboard Laby Seal w/O-rings | | | | | | | | | | | |
| 351 | 1 | Casing Gasket | | | | | | | | | | | |
| 353 | 4 | Gland Stud | | | 2229 | | | | | | | | 2150 |
| 355 | 4 | Gland Stud Nut | | | 2228 | | | | | | | | 2150 |
| 358A | 1 | Plug—Casing Drain | | 2210 | 2229 | 2230 | 2232 | 2150 | 2155 | 2248 | 2247 | 2156 | |
| 360D | 1 | Gasket—Frame to Adapter | | | | | | | | | | | |
| 360Q | 1 | Gasket—Gland to S. B. Cover | | | | | | | | | | | |
| 361A | 1 | Retaining Ring | | | | | | | | | | | |
| 370 | ★ | Bolt—Adapter to Case | | 2210 | | | | | | | | | 2228 |
| 370B | 4 | Bolt—Frame to Adapter | | | | | | | | | | | 2210 |
| 370C | * | Clamp Bolt—Brg Housing | | | | | | | | | | | 2210 |
| 370D | * | Jack Bolt—Brg Housing | | | | | | | | | | | 2210 |
| 370F | 2 | Bolt—Frame Foot to Frame | | | | | | | | | | | 2210 |
| 370G | 6 | Bolt—End Cover to Brg Housing | | | | | | | | | | | 2210 |
| 370H | 2 | Stud—S. B. Cover to Adapter | | | | | | | | | | | 2228 |
| 382 | 1 | Bearing Lockwasher | | | | | | | | | | | Steel |
| 383 | 1 | Mechanical Seal | | | | | | | | | | | Material Varies |
| 408A | 1 | Plug—Oil Drain | | | | | | | | | | | 2210 |
| 408H | 4 | Plug—Oil Mist Connection | | | | | | | | | | | 2210 |
| 408J | 1 | Plug—Oiler | | | | | | | | | | | 2210 |
| 408L | 1 | Plug—Oil Cooler Inlet | | | | | | | | | | | 2210 |
| 408M | 1 | Plug—Oil Cooler Outlet | | | | | | | | | | | 2210 |
| 408N | 1 | Plug—Sight Glass | | | | | | | | | | | 2210 |
| 418 | 3 | Jack Bolt—Adapter to Case | | | | | | | | | | | 2228 |
| 423 | 3 | Jam Nut—Brg Hsg Jack Bolt | | | | | | | | | | | 2210 |
| 423B | 2 | Hex Nut—S.B. Cover to Adapter | | | | | | | | | | | 2228 |
| 428D | □ | Gasket, Plug | | | | | | | | | | | Teflon |
| 458Y | X | Impeller Plug | | 2229 | | 2230 | | 2232 | 2150 | 2155 | 2248 | 2247 | 2156 |
| 469B | 2 | Dowel Pin—Frame to Adapter | | | | | | | | | | | Steel |
| 496 | 1 | O-ring Bearing Housing | | | | | | | | | | | Buna N |
| 496A | 1 | O-ring—Impeller | | | | | | | | | | | Teflon |
| 497F | 1 | O-ring—Outboard Laby Rotor | | | | | | | | | | | Viton |
| 497G | 1 | O-ring—Outboard Laby Stator | | | | | | | | | | | Viton |
| 497H | 1 | O-ring—Inboard Laby Rotor | | | | | | | | | | | Viton |
| 497J | 1 | O-ring—Inboard Laby Stator | | | | | | | | | | | Viton |
| 529 | 1 | Lockwasher—Frame Foot to Frame | | | | | | | | | | | Steel |

| | | | | |
|---|---|--|---|--|
| * 3 for STX, MTX, LTX 4 for XLT-X, X17 | ★ Qty 4 for 6" STX 8 for 8" STX 8 for 8" MTX 12 for 10" MTX, LTX | 16 for 13" MTX, LTX, XLT-X 24 for 15" XLT-X 12 for X17 | ▲ 2229 for Mech Seals 2237 all other | X XLT-X & X17 only Qty 1 □ XLT-X & X17 for repairs only Qty 1 |
|---|---|--|---|--|

MATERIAL CROSS REFERENCE CHART

| Material | Goulds Pumps Material Code | ASTM | DIN | ISO | JIS |
|--------------|----------------------------|-----------------|--------|-----|---------------|
| Cast Iron | 1001 | A48 CLASS 20 | | | |
| Ductile Iron | 1012 | A395 Gr60-40-18 | | | |
| Ductile Iron | 1013 | A536 Gr60-42-10 | | | |
| Monel | 1119 | A494 GrM-35-1 | | | |
| 316SS | 1203 | A744 CF-8M | 1.4408 | | G5121 (SC514) |
| Alloy 20 | 1204 | A744CN-7M | 1.4500 | | |
| 317SS | 1209 | A744CG-8M | 1.4448 | | |
| Hastelloy C | 1215 | A494 CW-2M | | | |
| CD4MCu | 1216 | A744CD4MCU | 9.4460 | | |
| Hastelloy B | 1217 | A494 N-7M | | | |
| Titanium | 1220 | B367 GrC-3 | | | |
| Nickel | 1601 | A494 GrCZ100 | | | |
| Monel | 2150 | B164 UNS N04400 | | | |
| Nickel | 2155 | B160 UNS N02200 | | | |
| Titanium | 2156 | B348 Gr2 | | | |
| Carbon Steel | 2210 | A108Gr1211 | | | |
| 304SS | 2228 | A276 Type 304 | | | |
| 316SS | 2229 | A276 Type 316 | | | |
| Carpenter 20 | 2230 | B473 (N08020) | | | |
| 317SS | 2232 | A276 | | | |
| 4150 Steel | 2237 | A322Gr4150 | | | |
| 4140 Steel | 2238 | A434Gr4140 | | | |
| Alloy B-2 | 2247 | B335 (N10665) | | | |
| Alloy C-276 | 2248 | B574 (N10276) | | | |

Fasteners/Plugs

| Material | Goulds Pumps Material Code | ASTM |
|---------------------|----------------------------|-----------|
| Carbon Steel | 2210 | A307Gr.B. |
| Stainless Steel | 2228 | F593Gr1 |
| 316 Stainless Steel | 2229 | F593Gr2 |

STX

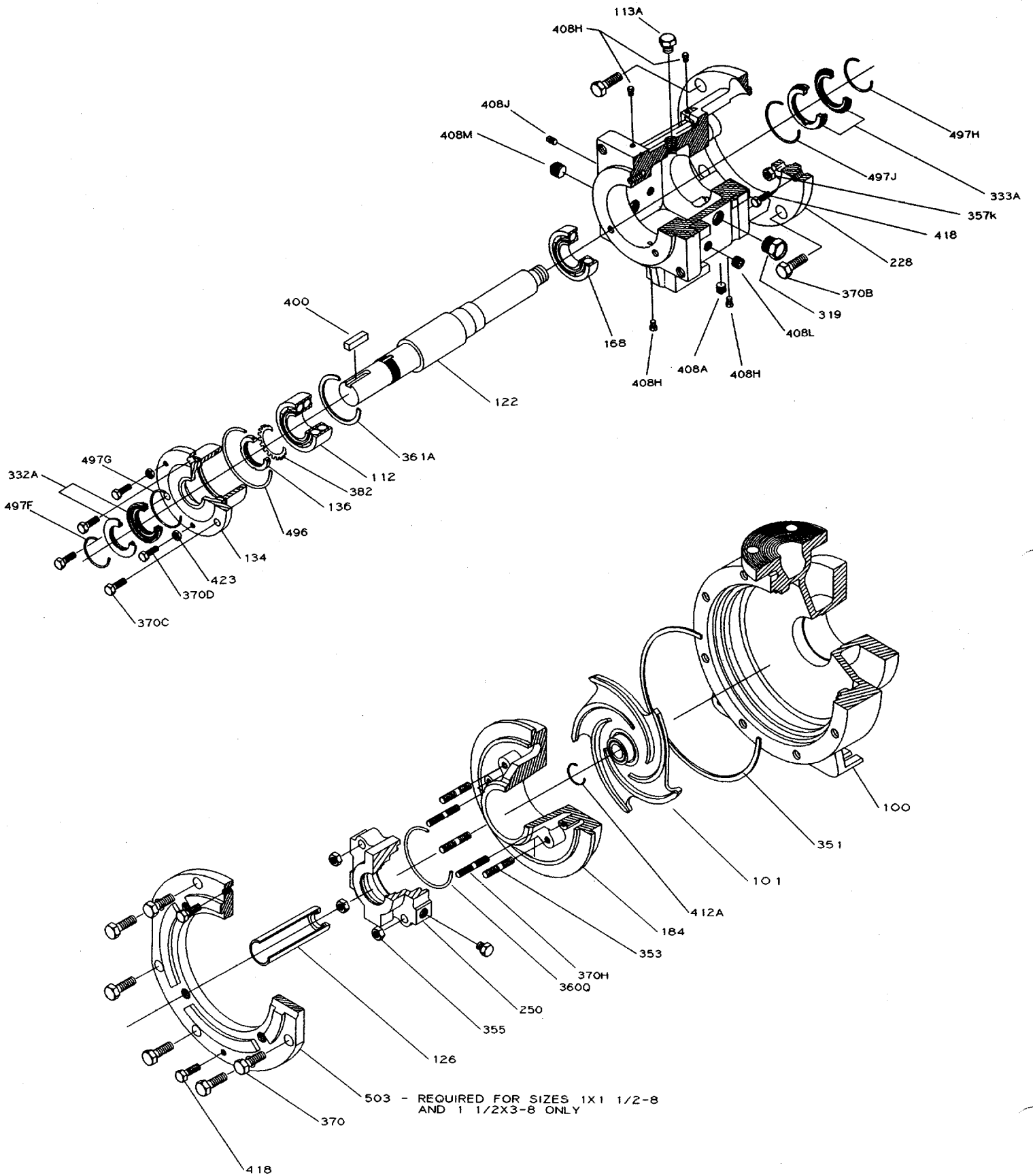

MTX

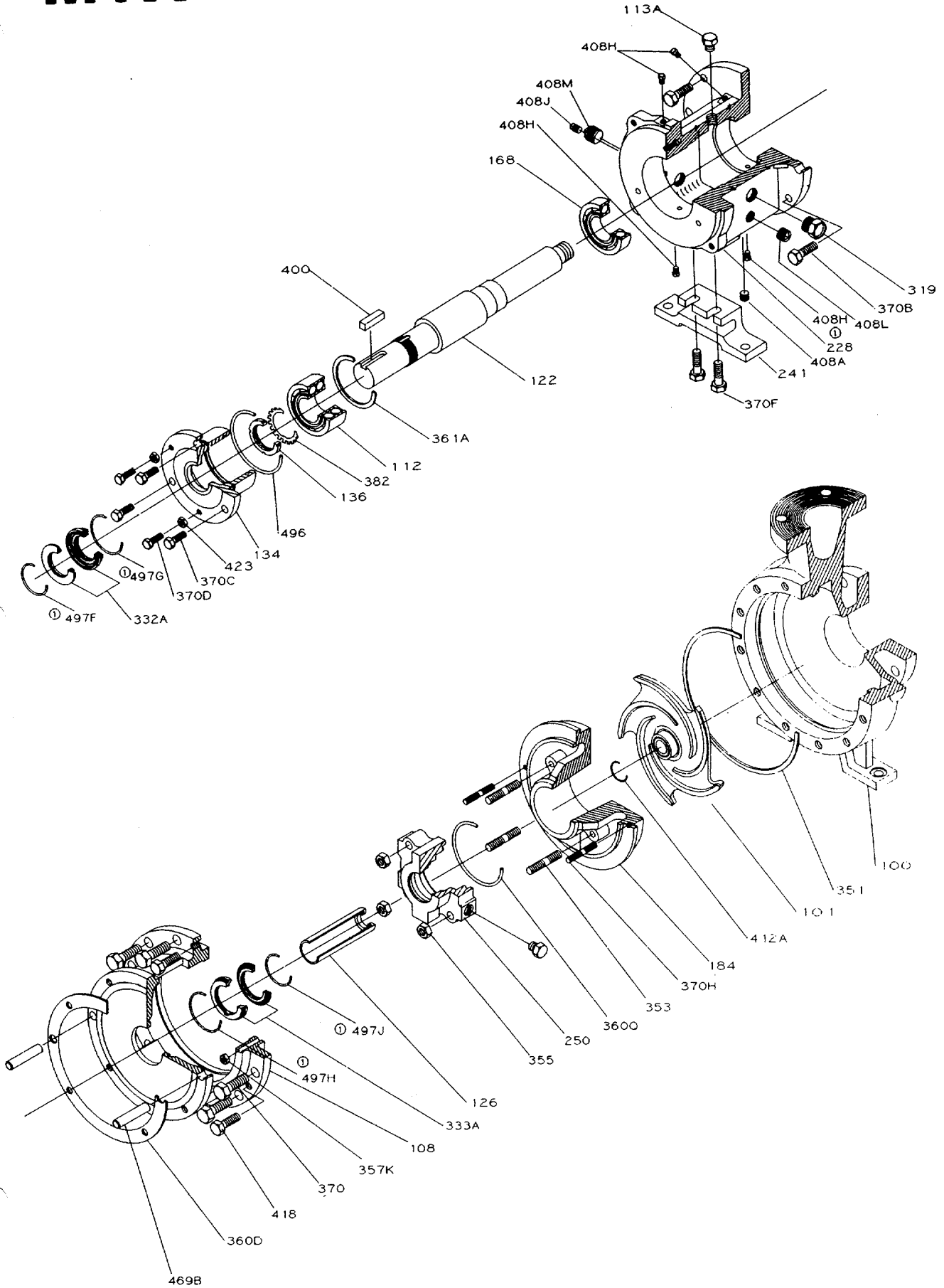

LTX

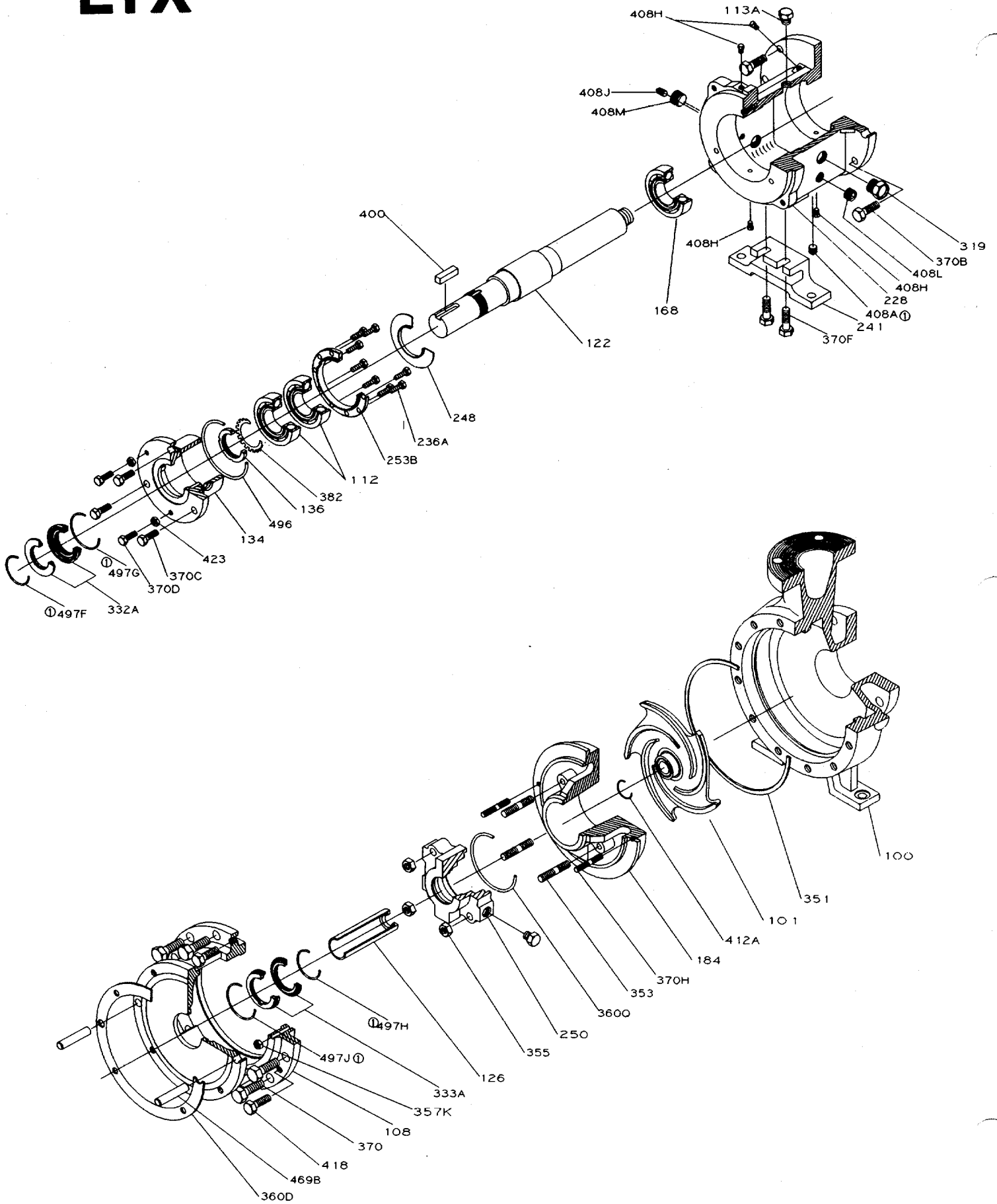

XLT-X

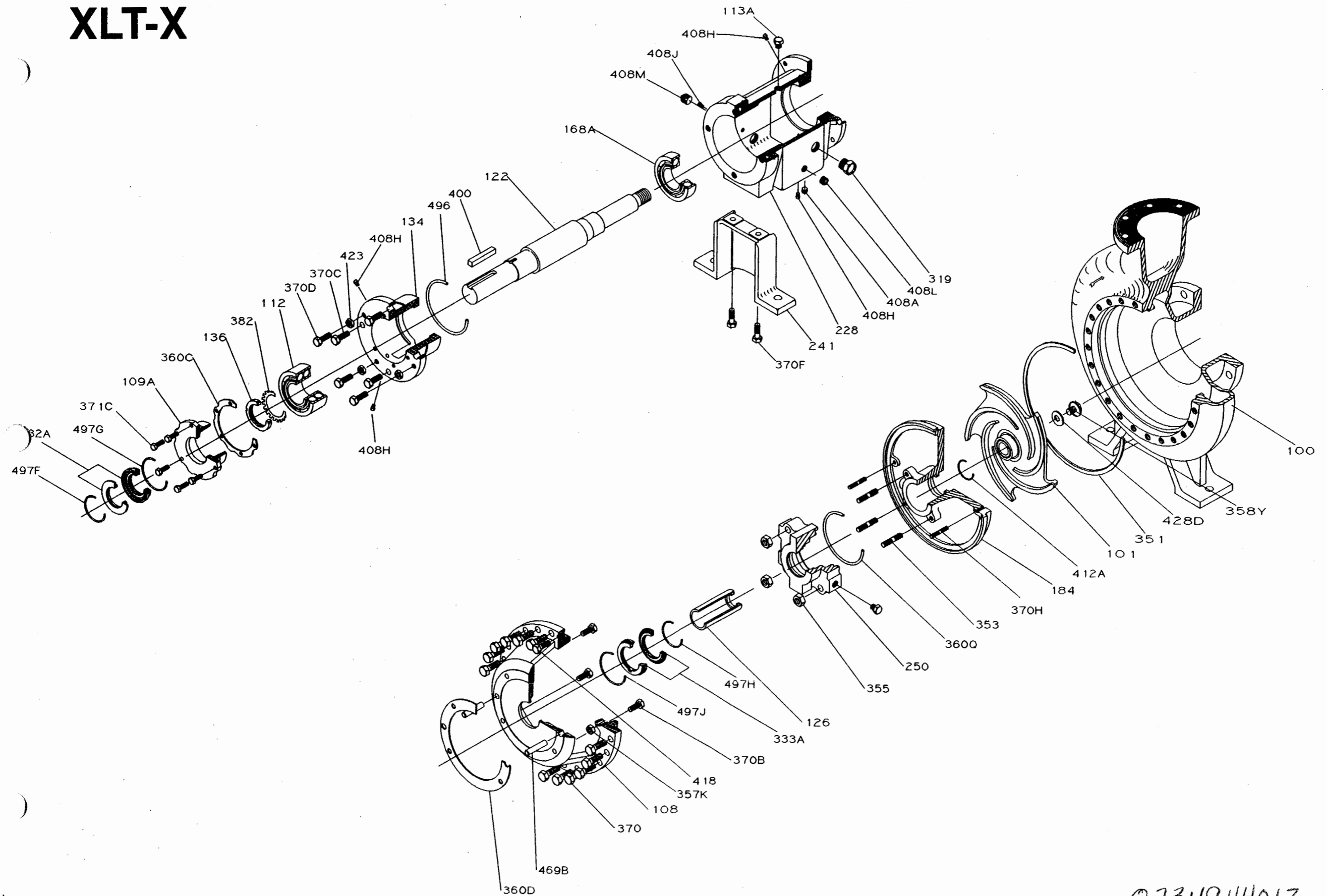

02.349HH01Z

SPARE PARTS

| | |
|--|-----------|
| RECOMMENDED SPARE PARTS | 77 |
| INTERCHANGEABILITY | 78 |
| HOW TO ORDER PARTS | 79 |
| APPENDIX I | 81 |
| APPENDIX II | 83 |
| APPENDIX III | 87 |

When ordering spare parts, always state Goulds Serial No., and indicate part name and item number from relevant sectional drawing. It is an imperative for service reliability to have a sufficient stock of readily available spares.

RECOMMENDED SPARE PARTS

Suggested Spare Parts

- Impeller (101)
- Shaft (122A)
- Shaft Sleeve (126)
- Outboard Bearing (112A)
- Inboard Bearing (168A)
- Casing Gasket (351)
- Frame-to-Adapter Gasket (360D)
- Bearing Housing Retaining Ring (361A)
- Bearing Lockwasher (382)
- Bearing Locknut (136)
- Impeller O-Ring (412A)
- Bearing Housing O-Ring (496)
- Outboard Labyrinth Seal Rotary O-Ring (497F)
- Outboard Labyrinth Seal Stationary O-Ring (497G)
- Inboard Labyrinth Seal Rotary O-Ring (497H)
- Inboard Labyrinth Seal Stationary O-Ring (497J)
- Lantern Ring Half (105) (Packed Stuffing Box)
- Stuffing Box Packing (106) (Packed Stuffing Box)
- Packing Gland (107) (Packed Stuffing Box)
- Impeller Gasket (428D) XLT-X & X17

INTERCHANGEABILITY

3196 MODULAR/DIMENSIONAL INTERCHANGEABILITY

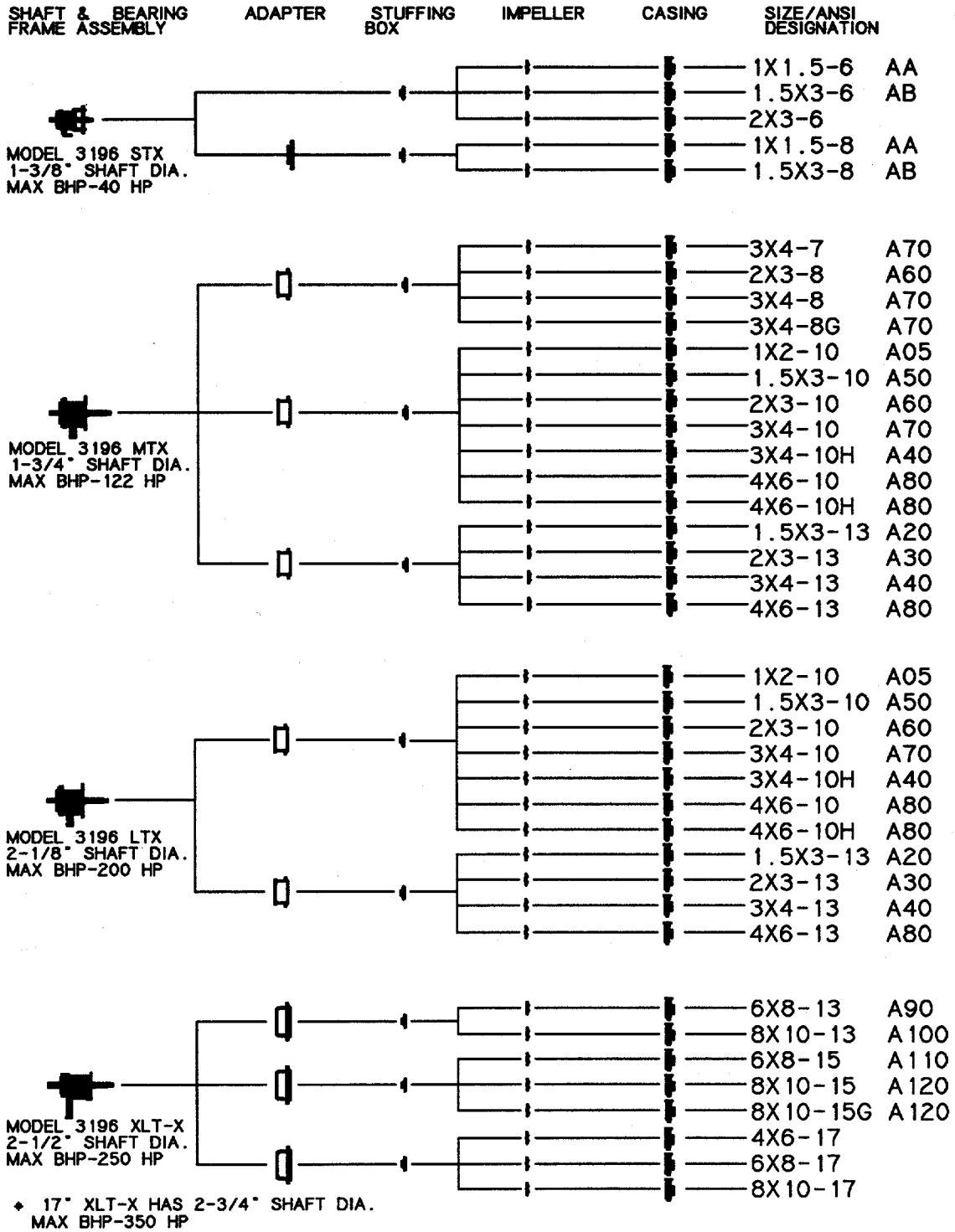

HOW TO ORDER

**When ordering parts call
1-800-446-8537
or your local Goulds Representative**

EMERGENCY SERVICE

**Emergency parts service is available
24 hours/day, 365 days/year . . .
Call 1-800-446-8537**

APPENDIX I

Lubrication Conversion

| | Pumpage Temperature below 350°F (177°C) | Pumpage Temperature above 350°F (177°C) |
|------------------|--|--|
| NLGI Consistency | 2 | 3 |
| Mobil | Mobilux EP2 | |
| Exxon | Unirex N2 | Unirex N3 |
| Sunoco | Multipurpose EP | |
| SKF | LGMT 2 | LGMT 3 |

Pumpage temperatures above 350°F (177°C) should be lubricated by a high temperature grease. Mineral oil greases should have oxidation stabilizers and a consistency of NLGI 3.

NOTE: If it is necessary to change grease type or consistency, the bearings must be removed and the old grease removed.



CAUTION

Never mix greases of different consistency (NLGI 1 or 3 with NLGI 2) or different thickener soaps (sodium or calcium with lithium). The consistency usually becomes softer and will not provide adequate lubrication to the bearings.

FRAME LUBRICATION CONVERSION

Conversion from Flood Oil to Pure Oil Mist

There are several ways to apply oil mist. Goulds has designed X-Series Power Ends to accept a variety of oil mist configurations. The following instructions are written for two popular systems in use.

NOTE: Make sure that pipe threads are clean and apply thread sealant to plugs & fittings.

NOTE: The LTX Requires that the bearing housing be changed when making the conversion from flood oil to oil mist lubrication. After the proper bearing housing has been installed follow the instructions as they apply to STX, MTX, XLT-X, X17.

A.

1. Attach oil mist inlet to 1/4" NPT connection at top, outboard end of frame (plugged with 408H allen head plug), and top, center of frame (plugged with 113A hex head plug).
2. Attach drain at bottom center of frame 3/8" NPT hole (plugged with 408A magnetic drain plug).
3. Follow oil mist generator manufacturer's instructions for oil mist volume adjustment, and operation.

B.

1. Attach oil mist inlet connection to 1/4" NPT connections at outboard and inboard ends of Power End.
2. Attach vent connection at 1/2" NPT hole located in top center of Power End.
3. Attach drain connection at 3/8" NPT hole located at bottom center of Power End (plugged with 408A magnetic drain plug).
4. Follow oil mist generator manufacturer's instructions for oil mist volume adjustment and operation.



CAUTION

Oil mist falls under Title III of the Clean Air Act and must be controlled or the user will be subject to penalty.

Conversion from Flood Oil to Regreaseable

NOTE: Make sure that pipe threads are clean and apply thread sealant to plugs and fittings.

NOTE: LTX regreaseable power end requires a changeout of the bearing housing and bearing clamp ring. This housing provides a grease path to the bearings.

1. Plug inboard oil return in bearing frame.

STX: Use epoxy, keep drilled hole clear.

MTX, LTX, XLT-X, X17: Use set screw, install from adapter side, bottom in hole.

2. Plug outboard oil return slot in bearing housing, keep through holes clear. (does not apply to LTX)
3. Replace both bearings with single shield type. Refer to Assembly Section for installation guidelines. (Ref. Bearing Chart Table 11)
4. Install grease fittings at top, inboard and top, outboard 1/4" NPT connections in bearing frame (plugged with 408H allen head plug).
5. Remove 2 (408H) Allen head plugs from bottom side of frame prior to greasing bearings. Reinstall hex head plugs (113) after bearings have been greased.

| ITEM NO. | SIZE | DESCRIPTION | QTY. |
|----------|----------------|---------------------------------------|------|
| 113 | 1/4"-18 NPT | EXT. HEX/SQUARE HEAD PIPE PLUG | 2 |
| 113A | 1/2"-14 NPT | EXT. HEX/SQUARE HEAD PIPE PLUG | 1 |
| 193 | 1/4"-18 NPT | GREASE FITTING | 2 |
| 228 | ---- | BEARING FRAME | 1 |
| 241 | ---- | FRAME FOOT | 1 |
| 370F | 1/2" | HEX CAP SCREW | 2 |
| 408A | 3/8"-18 NPT | EXT. SQUARE HEAD PIPE PLUG(MAGNETIC) | 1 |
| 408J | 1/4"-18 NPT | EXT. HEX/SQUARE HEAD PIPE PLUG | 1 |
| 408L | 1/2"-14 NPT | SQUARE COUNTERSUNK HEADLESS PIPE PLUG | 1 |
| 408M | 1" 11-1/2" NPT | SQUARE COUNTERSUNK HEADLESS PIPE PLUG | 1 |
| 319 | 1" 11-1/2" NPT | SIGHT WINDOW | 1 |
| 529 | 1/2" | LIGHT HELICAL SPRING LOCK WASHER | 2 |

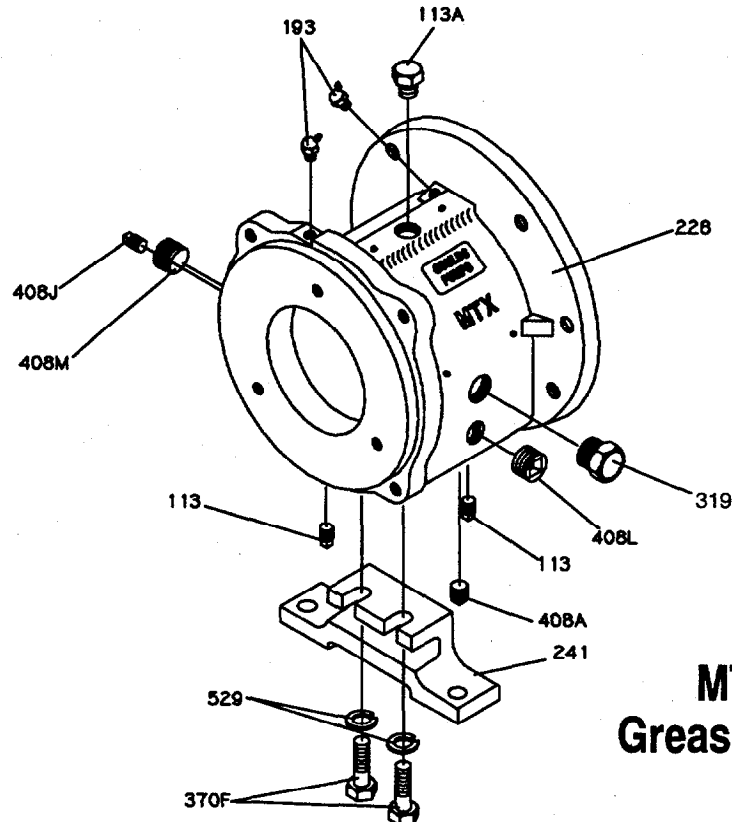

MTX
Grease Lube

APPENDIX II

Installation Instructions for Goulds ANSI B15.1 Coupling Guards



WARNING

Before assembly or disassembly of the coupling guard is performed the motor must be de-energized, the motor controller/starter put in a locked-out position and a caution tag placed at the starter indicating the disconnect. Replace coupling guard before resuming normal operation of the pump. Goulds Pumps, Inc. assumes no liability for avoiding this practice.

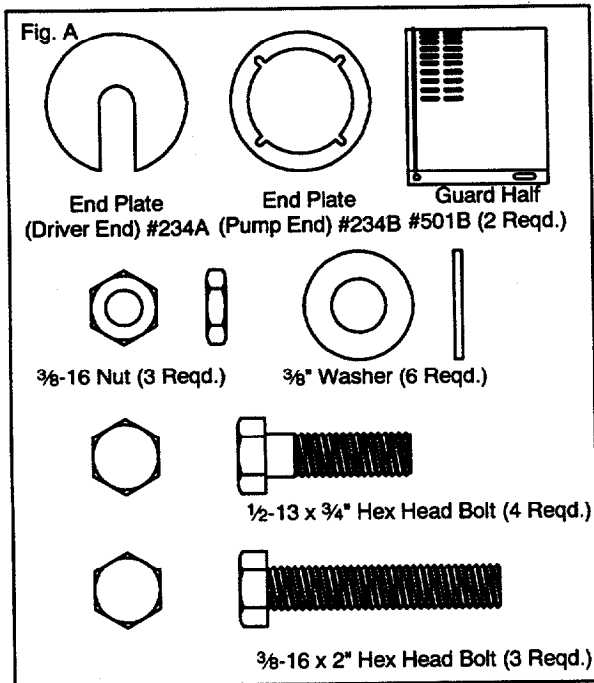

Simplicity of design allows complete assembly of the coupling guard, including the end plate (pump end), in about fifteen minutes. If the end plate is already in place, assembly can be accomplished in about five minutes.

Assembly:

NOTE: If end plate (pump end) is already installed, make any necessary coupling adjustments and then proceed to Step 2.

1. **XLT-X ONLY** Align the end plate (pump end) to the pump bearing housing so that the large slots on the end plate clear the bearing housing tap bolts and the small slots are aligned to the impeller adjusting bolts. Attach the end plate to the bearing housing using the jam nuts on the impeller adjusting bolts as shown in Fig. B.

After the end plate is attached to the bearing housing, the impeller clearance must be checked and reset as explained in the Goulds operations and maintenance manual for your pump.

STX, MTX, LTX - Align end plate (pump end) to the Bearing Frame. (No impeller adjustment required)

NOTE: Coupling adjustments should be completed before proceeding with coupling guard assembly.

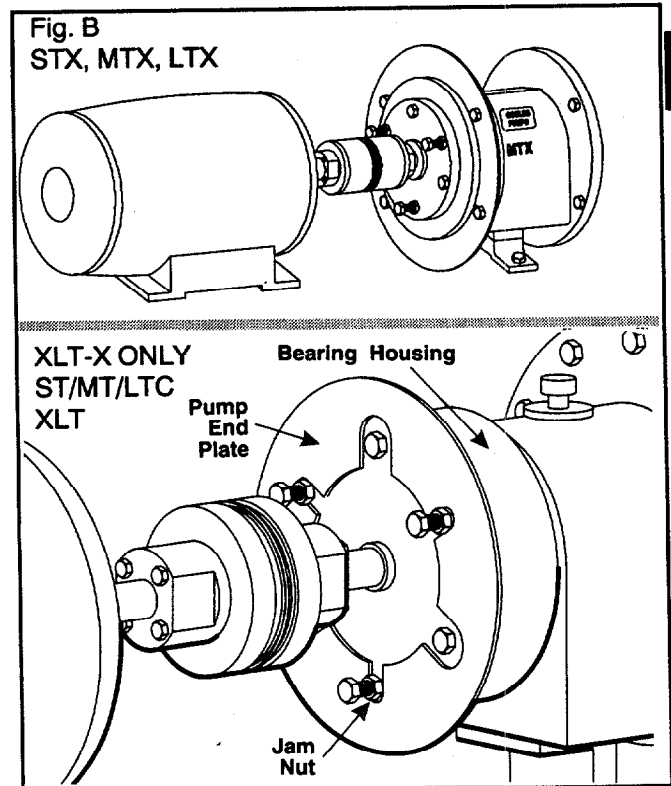

- Spread bottom of coupling guard half (pump end) slightly and place over pump end plate as shown in Fig. C. The annular groove in the guard half is located around the end plate. See detail drawing, Fig. E.

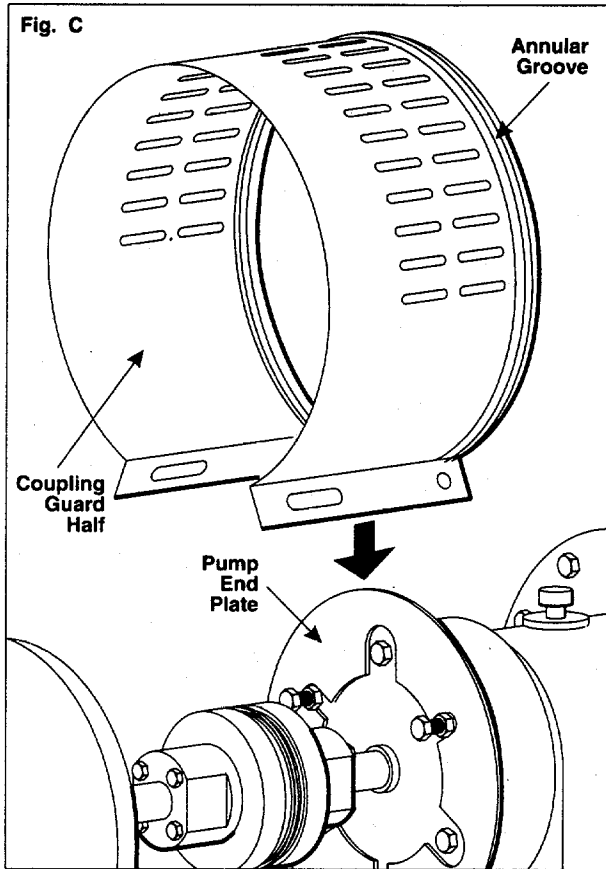

- After the coupling guard half (pump end) is located around the end plate, secure it with a bolt, nut and two (2) washers through the round hole at the front end of the guard half as shown in Fig. D. Tighten securely. See detail drawing, Fig. E.

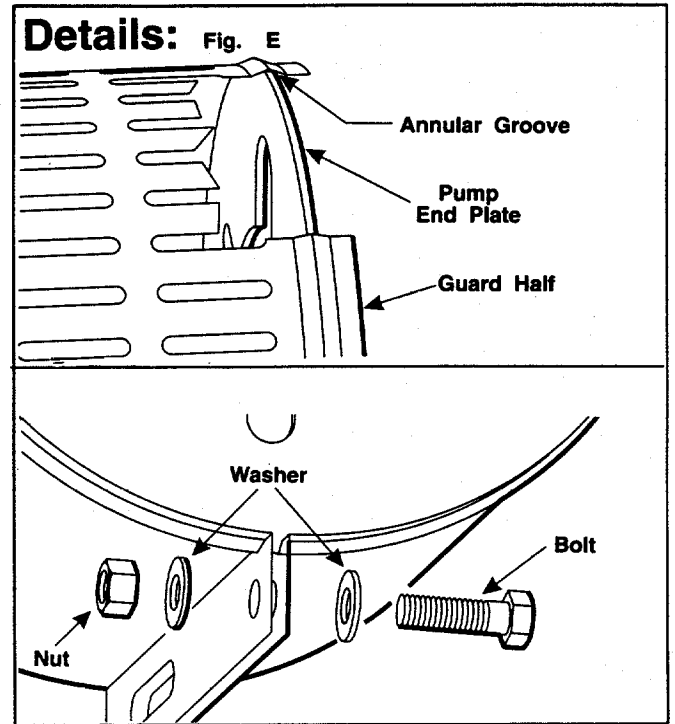
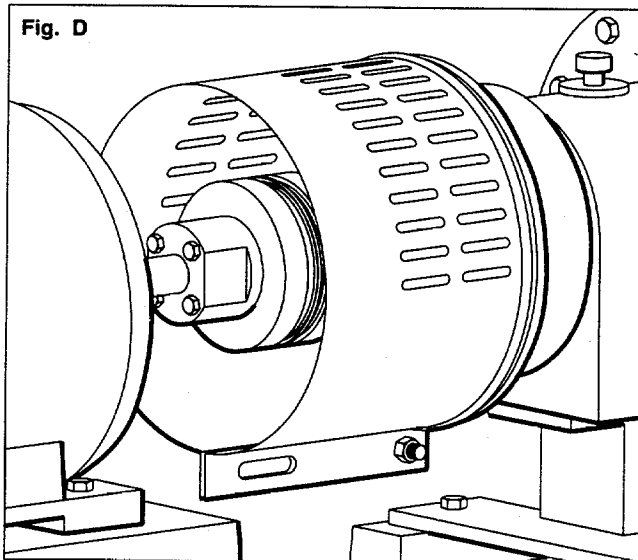

- Spread bottom of coupling guard half (driver end) slightly and place over coupling guard half (pump end) so that annular groove in coupling guard half (driver end) faces the motor as shown in Fig. F.

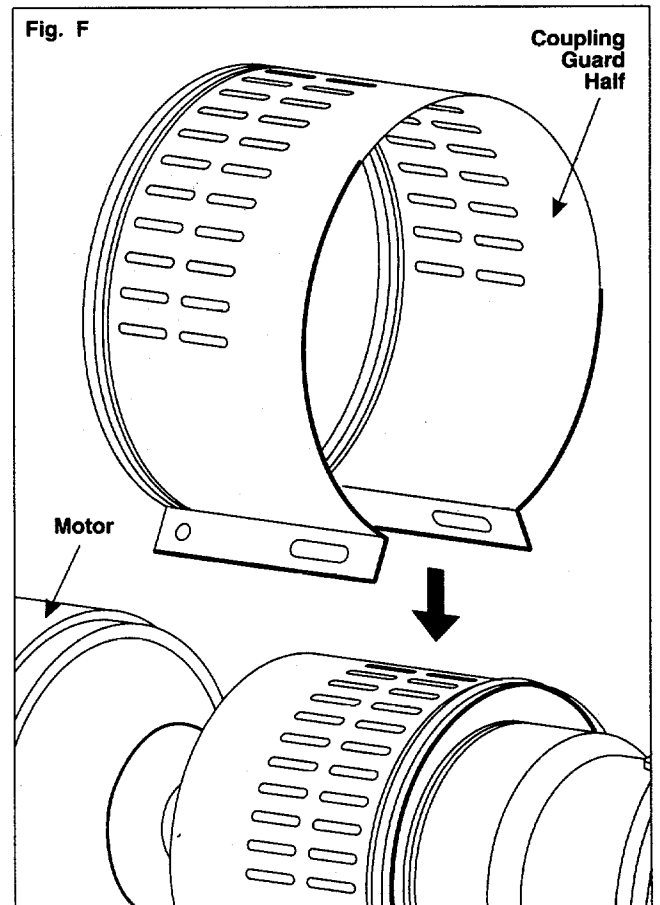

- Place end plate (driver end) over motor shaft as shown in Fig. G. Locate the end plate in the annular groove at the rear of the coupling guard half (driver end) and secure with a bolt, nut, and two (2) washers through the round hole at the rear of the guard half. Finger tighten only.

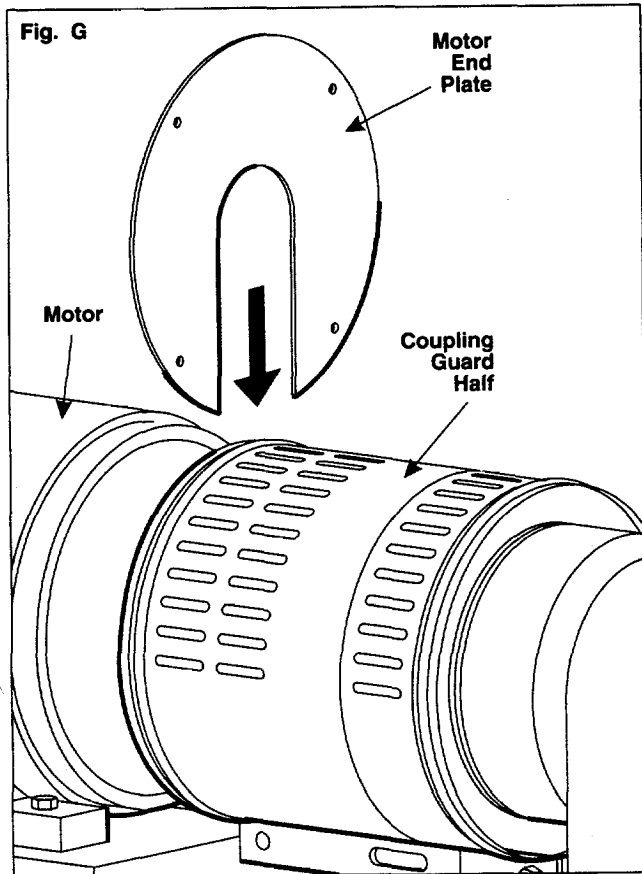

- Adjust length of coupling guard to completely cover shafts and coupling as shown in Fig. H by sliding coupling guard half (driver end) towards motor. After adjusting guard length, secure with bolt, nut and two (2) washers through the slotted holes at the center of the guard and tighten. Check all nuts on the guard assembly for tightness.



WARNING

Before assembly or disassembly of the coupling guard is performed the motor must be de-energized, the motor controller/starter put in a locked-out position and a caution tag placed at the starter indicating the disconnect. Replace coupling guard before resuming normal operation if the pump. Goulds Pumps, Inc. assumes no liability for avoiding this practice.

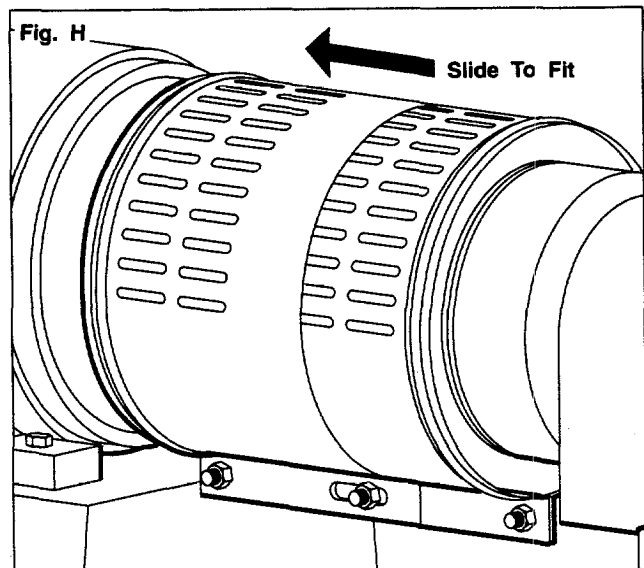

Disassembly

The coupling guard must be removed for certain maintenance and adjustments to the pump, such as adjustment of the coupling, impeller clearance adjustment, etc. The coupling guard should be replaced after maintenance is completed.

DO NOT resume normal pump operation with the coupling guard removed.

NOTE: Refer to illustrations for assembly in reverse order.

- Remove nut, bolt, and washers from center slotted hole in the coupling guard. Slide motor end coupling guard half towards pump. Fig. H.
- Remove nut, bolt, and washers from coupling guard half (driver end), and remove end plate. Fig. G.
- Spread bottom of coupling guard half slightly and lift off. Fig. F.
- Remove remaining nut, bolt, and washers from coupling guard half (pump end). Spread bottom of coupling guard half slightly and lift off. Fig. C.

This completes disassembly of the coupling guard.

NOTE: It is not necessary to remove the end plate (pump end) from the pump bearing housing. The bearing housing tap bolts are accessible without removing the end plate in case maintenance of internal pump parts is necessary. Before removing the pump bearing housing, refer to the Goulds operations and maintenance manual for your particular pump.

APPENDIX III

MODEL 3196 RECOMMENDED MINIMUM FLOW (GPM @ MAXIMUM DIAMETER)

| Size | 2 Pole 60 Hz 3560 RPM | 2 Pole 50 Hz 2900 RPM | 4 Pole 60 Hz 1780 RPM | 4 Pole 50 Hz 1470 RPM | 6 Pole 60 Hz 1180 RPM | 6 Pole 50 Hz 960 RPM | 8 Pole 60 Hz 885 RPM |
|---------------------|--------------------------|--------------------------|--------------------------|--------------------------|--------------------------|-------------------------|-------------------------|
| 1 x 1½ - 6 STX | 10 | 5 | 3 | 1 | | | |
| 1½ x 3 - 6 STX | 20 | 9 | 5 | 2 | | | |
| 2 x 3 - 6 STX | 40 | 26 | 9 | 3 | | | |
| 1 x 1½ - 8 STX | 20 | 13 | 5 | 2 | | | |
| 1½ x 3 - 8 STX | 40 | 23 | 6 | 2 | | | |
| 3 x 4 - 7 MTX | 125 | 77 | 13 | 4 | | | |
| 2 x 3 - 8 MTX | 60 | 35 | 9 | 4 | | | |
| 3 x 4 - 8 MTX | N/A | 181 | 100 | 31 | 17 | | |
| 3 x 4 - 8G MTX | 190 | 104 | 26 | 11 | | | |
| 1 x 2 - 10 MTX | 40 | 22 | 5 | 3 | 3 | | |
| 1½ x 3 - 10 MTX | 80 | 56 | 14 | 6 | 5 | | |
| 2 x 3 - 10 MTX | 200 | 73 | 19 | 6 | 3 | | |
| 3 x 4 - 10 MTX | 200 | 181 | 50 | 20 | 12 | | |
| 3 x 4 - 10H MTX | N/A | N/A | 150 | 76 | 30 | 11 | |
| 4 x 6 - 10 MTX | N/A | N/A | 450 | 117 | 79 | 24 | |
| 4 x 6 - 10H MTX | N/A | N/A | 400 | 153 | 85 | 46 | |
| 1½ x 3 - 13 MTX/LTC | 180 | 106 | 45 | 23 | 11 | | |
| 2 x 3 - 13 MTX/LTC | 240 | 171 | 63 | 37 | 18 | | |
| 3 x 4 - 13 MTX/LTC | 400 | 333 | 168 | 104 | 67 | 31 | |
| 4 x 6 - 13 MTX | N/A | N/A | 370 | 297 | 150 | 89 | |
| 6 x 8 - 13 XLT-X | N/A | N/A | 850 | 480 | 375 | 197 | |
| 8 x 10 - 13 XLT-X | N/A | N/A | 1200 | 977 | 570 | 383 | |
| 6 x 8 - 15 XLT-X | N/A | N/A | 1000 | 726 | 462 | 277 | |
| 8 x 10 - 15 XLT-X | N/A | N/A | N/A | 1400 | 1000 | 770 | 522 |
| 8 x 10 - 15G XLT-X | N/A | N/A | 1400 | 1375 | 847 | 604 | 511 |
| 4 x 6 - 17 XLT-X | N/A | N/A | 900 | 530 | 351 | 214 | |
| 6 x 8 - 17 XLT-X | N/A | N/A | 1400 | 1136 | 778 | 519 | |
| 8 x 10 - 17 XLT-X | N/A | N/A | 2150 | 1598 | 1148 | 702 | 676 |

 **GOULDS PUMPS, INC.**
INDUSTRIAL PRODUCTS GROUP
Seneca Falls, New York 13148

Form No. EPD-166 Rev. 1/94



Printed in U.S.A.

APPENDIX H

SECTION 2

PUMP DATA

PUMPS P - 025, 025A & P - 115

Manufacturer: Barnes

Model: Series: SE ½ HP

Manufacturer

Contact: Barnes Pumps

Phone

Number: (513) 773-2238

BARNES[®]

INSTALLATION and OPERATION MANUAL

Submersible Sewage Ejector

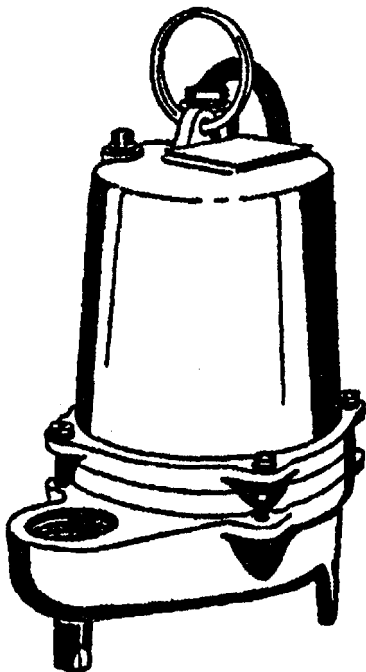

**SERIES: SE .5 HP & 1.0HP
1750 RPM & 3450RPM**



**CSA[®] Canadian Standards Association
File No. LR16567**

CSA Listing Is For The Following Models ONLY:
SE514L, SE524L, SE1024L, SE512L, SE522
& SE1022L.

IMPORTANT: Read all instructions in this manual before operating pump.
As a result of Barnes[®] Pumps constant product improvement program, product changes may occur. As such Barnes Pumps reserves the right to change product without prior written notification.

CRANE

PUMPS & SYSTEMS

Barnes Pumps, Inc.
420 Third Street/P.O. Box 603
Piqua, Ohio 45356-0603
Phone: (513) 773-2442
Fax: (513) 773-2238



Form No. 088634-0894

TABLE OF CONTENTS

| | |
|--------------------------------------|---------|
| WARNINGS AND SAFETY PRECAUTIONS..... | 3 |
| A. PUMP SPECIFICATIONS..... | 4 |
| PUMP DIMENSIONS | 5 |
| B. GENERAL INFORMATION | 6 |
| C. INSTALLATION INSTRUCTIONS..... | 7 - 9 |
| D. START-UP OPERATION | 10 |
| E. PREVENTATIVE MAINTENANCE | 10 |
| F. SERVICE AND REPAIR | 11 - 15 |
| TROUBLESHOOTING | 16 - 17 |
| G. REPLACEMENT PARTS | 18 |
| CROSS-SECTION (Fig. 9)..... | 19 |
| EXPLODED VIEW (Fig. 10)..... | 20 |
| PARTS LIST..... | 21 - 24 |
| WARRANTY INFORMATION | 25 |
| WARRANTY | |
| START UP REPORT | |
| WARRANTY REGISTRATION | |

SPECIAL TOOLS and EQUIPMENT:

INSULATION TESTER (MEGGER)
DIELECTRIC TESTER
SEAL TOOL KIT (see parts list)
PRESSURE GAUGE KIT (see parts list)

SAFETY FIRST!

PLEASE READ THIS BEFORE INSTALLING OR OPERATING PUMP.

GENERAL

1. Most accidents can be avoided by using **COMMON SENSE**.
2. Read the operation and maintenance instruction manual supplied with the pump.
3. Do not wear loose clothing that may become entangled in the impeller or other moving parts.
4. Always wear appropriate safety gear, such as safety glasses, when working on the pump or piping.

PUMPS

5. Pumps build up heat and pressure during operation-allow time for pumps to cool before handling or servicing.
6. Only qualified personnel should install, operate and repair pump.
7. Keep clear of suction and discharge openings. **DO NOT** insert fingers in pump with power connected.
8. Do not pump hazardous materials (flammable, caustic, etc.) unless the pump is specifically designed and designated to handle them.
9. Do not block or restrict discharge hose-be careful of discharge hose whipping under pressure.
10. Make sure lifting handles are securely fastened each time before lifting.
11. Do not lift pump by the power cord.
12. Do not exceed manufacturers recommendation for maximum performance, as this could cause the motor to overheat.
13. Secure the pump in its operating position so it can not tip over, fall or slide.
14. Keep hands and feet away from impeller when power is connected.
15. Submersible Pumps are not approved for use in swimming pools, recreational water installations, decorative fountains or any installation where human contact with the pumped fluid is common.
16. Do not operate pump without guards and safety devices in place.
17. When towing pump behind a vehicle; make sure hitch is properly attached, always attach safety chains.
18. Always replace safety devices that have been removed during service or repair.

ELECTRICAL

19. To reduce risk of electrical shock, pump must be properly grounded in accordance with the National Electric Code and all applicable state and local codes and ordinances.
20. To reduce risk of electrical shock, always disconnect the pump from the power source before handling or servicing.
21. Any wiring of pumps should be performed by a qualified electrician.
22. Never operate a pump with a power cord that has frayed or brittle insulation.
23. Cable should be protected at all times to avoid punctures, cut, bruises and abrasions - inspect frequently.
24. Never handle connected power cords with wet hands.
25. Never operate a pump with a plug-in type power cord without a ground fault circuit interrupter.

GAS/DIESEL ENGINE POWER PUMPS ONLY

26. Never operate in a enclosed building or area where exhaust gases can accumulate.
27. Do not breath exhaust fumes when working in the area of the engine. (Exhaust gases are odorless and deadly poison.)
28. Never operate near a building where exhaust gases can seep inside.
29. Never operate in a pit or sump without making provisions for adequate ventilation.
30. Allow exhaust system to cool before touching.
31. Never add fuel to the tank while the engine is running. Stop engine and allow to cool.
32. Do not smoke while refueling the engine.
33. Do not refuel near open flame.

IMPORTANT! Barnes® Pumps, Inc. is not responsible for losses, injury, or death resulting from a failure to observe these safety precautions, misuse or abuse of pumps or equipment.

SECTION: A- PUMP SPECIFICATIONS

DISCHARGE: 2" NPT, Vertical
TEMPERATURE: 104° F Continuous.
VOLUTE: Cast Iron ASTM A-48, Class 30.
MOTOR HOUSING: Cast Iron ASTM A-48, Class 30.
SEAL PLATE: Cast Iron ASTM A-48, Class 30.
IMPELLER:
Design: 2 Vane, Open, With Pump Out Vanes On Back Side. Dynamically Balanced, ISO G6.3.
Material: Cast Iron ASTM A-48, Class 30.
SHAFT: 416 Stainless Steel.
SQUARE RINGS: Buna-N
HARDWARE: 300 Series Stainless Steel.
PAINT: Air Dry Enamel.
SEAL: *Design:* Single Mechanical, Oil-Filled Reservoir, Secondary Exclusion Seal.
Material: Rotating Face - Carbon
 Stationary Face - Ceramic
 Elastomer - Buna-N
 Hardware - 300 Series Stainless
CABLE ENTRY: 15 ft. Cord w/Plug On 115 volt, Pressure Grommet For Sealing And Strain Relief.
SPEED: 1750RPM or 3450RPM (Nominal).

UPPER BEARING:
Design: Sleeve
Lubrication: Oil
Load: Radial
LOWER BEARING:
Design: Single Row, Ball
Lubrication: Oil
Load: Radial & Thrust
MOTOR:
Design: NEMA L - Single Phase, NEMA B - Three Phase Torque Curve. Completely Oil-Filled, Squirrel Cage Induction.
Insulation: Class A.
SINGLE PHASE: Permanent Split Capacitor (PSC). Includes Overload Protection In Motor.
THREE PHASE: Tri Voltage 200-230/460. Requires Overload Protection to be Included in Control Panel.
OPTIONAL EQUIPMENT: Seal Material, Additional Cable, CSA Listed for 3 Phase Pumps.

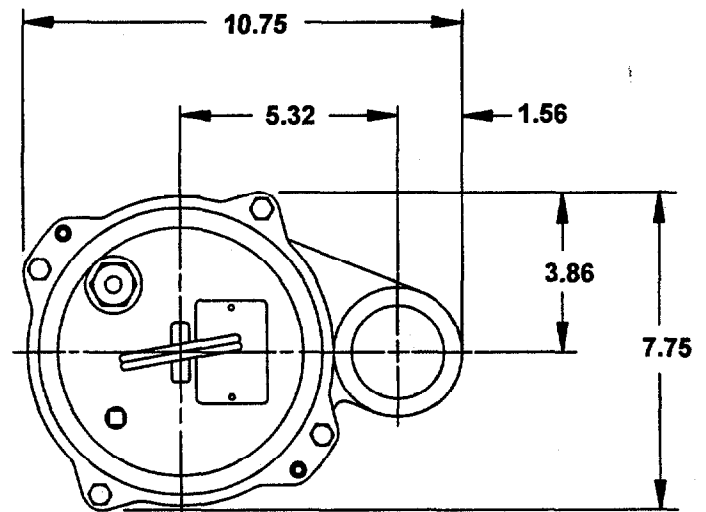
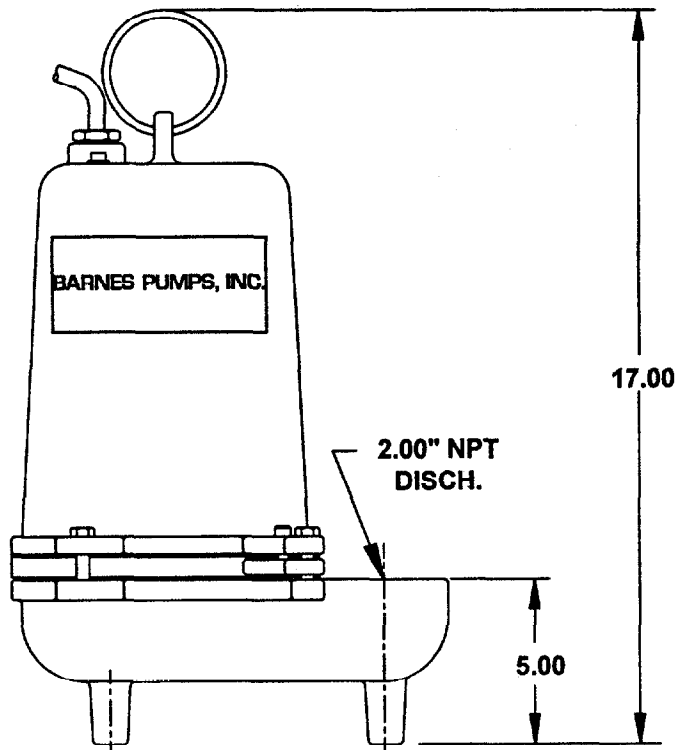

SECTION B: GENERAL INFORMATION

B-1) To the Purchaser:

Congratulations! You are the owner of one of the finest pumps on the market today. Barnes® Pumps are products engineered and manufactured of high quality components. Over ninety-five years of pump building experience along with a continuing quality assurance program combine to produce a pump which will stand up to the toughest sewage removal projects.

This Barnes Pumps, Inc. manual will provide helpful information concerning installation, maintenance, and proper service guidelines.

B-2) Receiving

Upon receiving the pump, it should be inspected for damage or shortages. If damage has occurred, file a claim immediately with the company that delivered the pump. If the manual is removed from the crating, do not lose or misplace.

B-3) Storage:

Short Term- Barnes Pumps are manufactured for efficient performance following long inoperative periods in storage. For best results, pumps can be retained in storage, as factory assembled, in a dry atmosphere with constant temperatures for up to six (6) months.

Long Term- Any length of time exceeding six (6) months, but not more than twenty four (24) months. The units should be stored in a temperature controlled area, a roofed over walled enclosure that provides protection from the elements (rain, snow, wind blown dust, etc.), and whose temperature can be maintained between +40 deg. F and +120 deg. F.

If extended high humidity is expected to be a problem, all exposed parts should be inspected before storage and all surfaces that have the paint scratched, damaged, or worn should be recoated with a water base, air dry enamel paint. All surfaces should then be sprayed with a rust-inhibiting oil.

Pump should be stored in its original shipping container and on initial start up, rotate impeller by hand to assure seal and impeller rotate freely.

If it is required that the pump be installed and tested before the long term storage begins, such installation will be allowed provided:

- 1) The pump is not installed under water for more than one (1) month.
- 2) Immediately upon satisfactory completion of the test, the pump is removed, thoroughly dried, repacked in the original shipping container, and placed in a temperature controlled storage area.

B-4) SERVICE CENTERS:

For the location of the nearest Barnes Pumps Service Center, check your catalog, your Barnes Pumps, Inc. representative or Barnes Pumps, Inc. Service Department in Piqua, Ohio, telephone (513) 773-2442.

SECTION C: INSTALLATION

C-1) Location:

These pumping units are self-contained and are recommended for use in a sump or basin. The sump or basin shall be vented in accordance with local plumbing codes. This pump is designed to pump effluent or wastewater, nonexplosive and noncorrosive liquids and shall **NOT** be installed in locations classified as hazardous in accordance with the National Electrical Code (NEC), ANSI/NFPA 70. Never install the pump in a trench, ditch, or hole with a dirt bottom; the legs will sink into the dirt and the suction will become plugged.

C-1.1) Submergence:

The pump should always be operated in the submerged condition. The minimum sump liquid level should never be less than 6 inches above the pump bottom. The recommended level should not drop below the top of the motor housing (see Fig. 1).

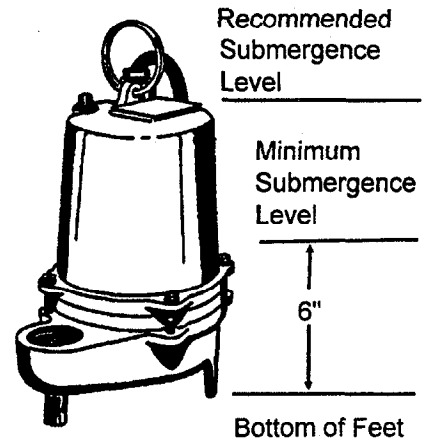

Fig. 1

C-2) Discharge:

Discharge piping should be as short as possible. Both a check valve and a shut-off valve are recommended for each pump being used. The check valve is used to prevent backflow into the sump. Excessive backflow can cause flooding and/or damage to the pump. The shut-off valve is used to stop system flow during pump or check valve servicing.

TYPICAL INSTALLATION WITH WIDE ANGLE LEVEL CONTROL

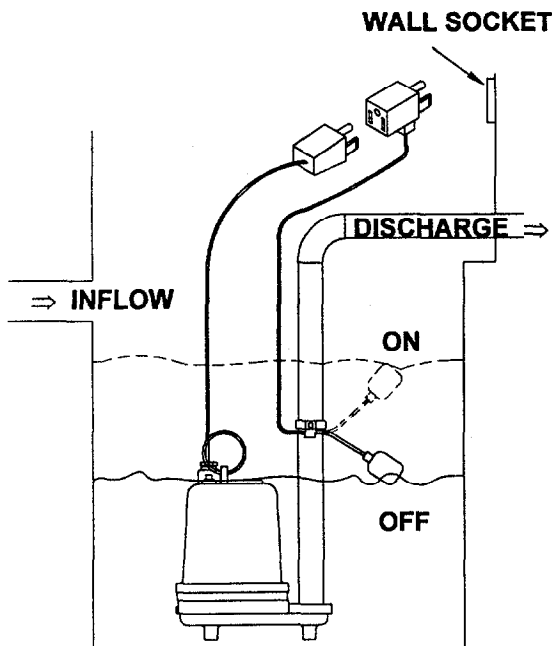

Fig. 2

Barnes Pumps supplies a Stainless Rail Package and also a variety of break-away fitting discharge systems designed to allow the submersible wastewater pump to be installed or removed without requiring personnel to enter the wet well. Contact your local Barnes Pumps distributor for complete details.

Stainless Rail Package (Not Shown)- The package system comes complete and ready to place into the ground as outlined in the project specifications. The moveable portion of the Break Away Fitting (BAF), check valve, piping and guide bracket comes assembled on the pump along with the lifting cable. Insert pump bracket and moveable portion of BAF into the guide channel and lower pump into basin (**DO NOT DROP**). Now connect power and control cables to the junction box or control panel depending on system design.

C-3) Liquid Level Controls

Figure 2 shows a typical installation for any submersible pump using a level control mounted to the discharge piping with a piggy-back plug.

General Comments:

- 1) Never work in the sump with the power on.
- 2) Level controls are factory set for a pumping differential of 9 inches. If that is the cycle desired, simply circle the discharge pipe with the pipe mounting strap, feed the end through the worm drive, and tighten with a screwdriver. Be certain that the level control cannot hang up or foul in its swing. Also, make certain the pump impeller is still submerged when the level control is in the 'off' mode.

3) If a higher pump differential is needed, grip the cord near the neck of the float, then using the other hand, exert a steady force on the lower edge of the cable clamp. The cable clamp should slide up to the new pivot point. Attach the level control to the discharge hose in the manner described above.

4) Plug the level control plug into the receptacle, then plug the pump into the piggyback plug. One cycle of operation should be observed, so that any potential problems can be corrected.

5) It is recommended that the float should be set to insure that the sump well liquid level never drops below the top of the motor housing or a minimum level of 6" above the pump bottom.

6.) Figure 3 shows a typical connection for pumps with the wide angle float and piggy-back plug. for manual and automatic operations.

- Automatic-** Plug float cord into outlet, then plug pump cord into float cord.
Manual- Plug pump cord directly into outlet.

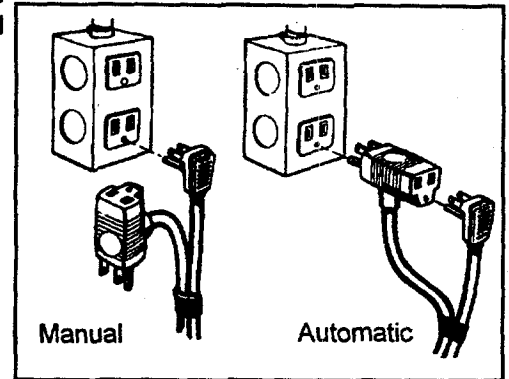

Fig. 3

C-4) Electrical Connections:

WARNING !
All model pumps and control panels must be properly grounded per the National Electric Code and your local electric code. Improper grounding voids warranty.

C-4.1) Power Cable:

The cord assembly mounted to the pump must not be modified in any way except for shortening to a specific application. Any splice between the pump and the control panel must be made in accordance with the National Electric Code and all applicable electric codes. It is recommended that a junction box, if used, be mounted outside the sump or be of at least NEMA 4 construction if located within the wet well.

Do not use the power cable to lift pump.

NOTE: The white wire is **NOT** a neutral or ground lead, but a power carrying conductor.

C-4.2) Overload Protection:

C-4.2-1) Single Phase - The type of in-winding overload protector used is referred to as an inherent overheating protector and operates on the combined effect of temperature and current. This means that the overload protector will trip out and shut the pump off if the windings become too hot, or the load current passing through them becomes too high. It will then automatically reset and start the pump up after the motor cools to a safe temperature. In the event of an overload, the source of this condition should be determined and rectified immediately.

DO NOT LET THE PUMP CYCLE OR RUN IF AN OVERLOAD CONDITION OCCURS

C-4.2-2) Three Phase - The normally closed (N/C) thermal sensor is embedded in the motor windings and will detect excessive heat in the event an overload condition occurs. The thermal sensor will trip when the windings become too hot and will automatically reset itself when the pump motor cools to a safe temperature. It is recommended that the thermal sensor be connected in series to an alarm device to alert the operator of an overload condition, and/or the motor starter coil to stop the pump. In the event of an overload, the source of this condition should be determined and rectified immediately.

DO NOT LET THE PUMP CYCLE OR RUN IF AN OVERLOAD CONDITION OCCURS !

| MODEL NO. | HP | VOLT | PH | RPM (Nom) | NEMA CODE | FULL LOAD AMPS | LOCKED ROTOR AMPS | CORD SIZE | CORD TYPE | CORD OD | EMERSON WINDING RESISTANCE MAIN/START | G.E. WINDING RESISTANCE MAIN/START |
|-----------|-----|---------|----|-----------|-----------|----------------|-------------------|-----------|-----------|---------|---------------------------------------|------------------------------------|
| SE514L | 0.5 | 115 | 1 | 1750 | F | 11.6 | 22.0 | 14/3 | SOW-A | 0.560 | 1.18--14.25 | 1.34--16.88 |
| SE524L | 0.5 | 230 | 1 | 1750 | K | 5.8 | 18.0 | 14/3 | SOW-A | 0.560 | 2.24--9.24 | 2.32--9.22 |
| SE594L | 0.5 | 200-230 | 3 | 1750 | E/G | 3.8/3.0 | 6.8/7.8 | 14/4 | SO | 0.600 | 6.00-- | 6.10-- |
| SE544L | 0.5 | 460 | 3 | 1750 | G | 1.7 | 3.9 | 14/4 | SO | 0.600 | 24.00-- | 24.40-- |
| SE554L | 0.5 | 575 | 3 | 1750 | H | 1.4 | 3.5 | 14/4 | SO | 0.600 | 38.58-- | |
| SE1024L | 1.0 | 230 | 1 | 1750 | C | 10.0 | 17.2 | 14/3 | SOW-A | 0.560 | 2.24--9.24 | 2.32--9.22 |
| SE1094L | 1.0 | 200-230 | 3 | 1750 | D/G | 6.1/5.5 | 12.8/14.8 | 14/4 | SO | 0.600 | 6.00-- | 6.10-- |
| SE1044L | 1.0 | 460 | 3 | 1750 | G | 2.7 | 7.4 | 14/4 | SO | 0.600 | 24.00-- | 24.40-- |
| SE1054L | 1.0 | 575 | 3 | 1750 | J | 2.2 | 7.2 | 14/4 | SO | 0.600 | 38.58-- | |
| SE512L | 0.5 | 115 | 1 | 3450 | F | 13.0 | 23.0 | 14/3 | SOW-A | 0.560 | 1.08--8.02 | 0.91--13.71 |
| SE522L | 0.5 | 230 | 1 | 3450 | F | 6.5 | 11.5 | 14/3 | SOW-A | 0.560 | 8.09--8.00 | 9.24--10.03 |
| SE532L | 0.5 | 230 | 3 | 3450 | G | 4.0 | 7.8 | 14/4 | SO | 0.600 | 8.57-- | 8.60-- |
| SE542L | 0.5 | 460 | 3 | 3450 | G | 2.0 | 3.9 | 14/4 | SO | 0.600 | 34.28-- | 34.40-- |
| SE552L | 0.5 | 575 | 3 | 3450 | G | 1.6 | 3.1 | 14/4 | SO | 0.600 | 58.00-- | |
| SE1022L | 1.0 | 230 | 1 | 3450 | B | 9.5 | 13.8 | 14/3 | SOW-A | 0.560 | 3.51--12.07 | 2.89--15.18 |
| SE1032L | 1.0 | 230 | 3 | 3450 | K | 5.0 | 21.2 | 14/4 | SO | 0.600 | 5.32-- | 6.11-- |
| SE1042L | 1.0 | 460 | 3 | 3450 | K | 2.5 | 10.7 | 14/4 | SO | 0.600 | 21.28-- | 24.44-- |
| SE1052L | 1.0 | 575 | 3 | 3450 | K | 2.0 | 8.6 | 14/4 | SO | 0.600 | 39.53-- | |

Winding Resistance \pm 5%

Optional - CSA Listed Power Cable for 3 phase models is 14/4 SOW-A, 0.600 O.D.

If current through the temperature sensor exceeds the values listed, an intermediate control circuit relay must be used to reduce the current or the sensor will not work properly.

Temperature Sensor Electrical Ratings

| <u>Volts</u> | <u>Continuous Amperes</u> | <u>Inrush Amperes</u> |
|--------------|---------------------------|-----------------------|
| 110-120 | 3.00 | 30.0 |
| 220-240 | 1.50 | 15.0 |
| 440-480 | 0.75 | 7.5 |

C-4.3) Wire Size:

Consult a qualified electrician for proper wire size. See table for electrical information.

SECTION: D START-UP OPERATION

D-1) Check Voltage and Phase:

Before operating pump check to make sure that the voltage and phase information stamped on the pump's identification plate matches the available power.

D-2) Check Pump Rotation:

Before putting pump into service for the first time, the motor rotation must be checked. Improper motor rotation can result in poor pump performance and can damage the motor and/or pump. To check the rotation, suspend the pump freely, momentarily apply power and observe the "kickback". "Kickback" should always be in a counter-clockwise direction as viewed from the top of the pump ("kickback" is always opposite to impeller rotation). "Rotation" and "kickback" direction is noted on the pump motor housing.

D-2.1) Incorrect Rotation for Single-Phase:

In the unlikely event that the rotation is incorrect for a single-phase pump, contact a Barnes Pumps Service Center.

D-2.2) Incorrect Rotation for Three-Phase pumps:

In the event that the rotation is incorrect for a three-phase installation, interchange any two power cable leads at the control box. **DO NOT** change leads in the cable housing in the motor. Recheck the "Kickback" rotation again by momentarily applying power.

D-3) Identification Plate:

Record the numbers off the pump's identification plate onto the START-UP REPORT provided at the end of the manual for future reference.

D-4) Start-Up Report:

Included at the end of this manual are two start-up report sheets. These sheets are to be completed as applicable. Return one copy to Barnes Pumps and store the second in the control panel or with the pump manual if no control panel is used. It is important to record this data at initial start-up since it will be useful to compare to when servicing the pump in the future.

Insulation Test:

Before the pump is put into service, an insulation (megger) test should be performed on it. The ohm values as well as the volts and amps should be recorded on the start-up sheet and stored safely in the control panel or with the pump manual if no control panel is used.

Pump-Down Test:

After the pump has been properly wired and lowered into the basin, sump, or lift station, it is advisable to check the system by filling with liquid and allowing the pump to operate through it's pumping cycle. The time needed to empty the system, or pump-down time, should be recorded on the start-up sheet.

SECTION E: PREVENTATIVE MAINTENANCE

As the motor is oil filled, no lubrication or other maintenance is required, and generally Barnes pumps will give very reliable service and can be expected to operate for years on normal sewage pumping without failure. However, as with any mechanical piece of equipment a preventive maintenance program is recommended and suggested to include the following checks:

- 1) Inspect motor chamber for oil level and contamination and repair as required per section F-1.
- 2) Inspect impeller and body for excessive build-up or clogging and repair as required per section F-2.
- 3) Inspect bearing and replace as required per section F-3.
- 4) Inspect seal for wear or leakage and repair as required per section F-4

SECTION F: SERVICE AND REPAIR

NOTE: All item numbers () refer to Figures 9 and 10.

WARNING !
ELECTRICAL POWER TO THE PUMP MOTOR MUST BE DISCONNECTED AND LOCKED OUT TO PREVENT ANY DANGEROUS ELECTRICAL HAZARDS OR PERSONNEL DANGER BEFORE ANY SERVICE WORK IS DONE TO THE PUMP.

CAUTION:
OPERATING PUMP BUILDS UP HEAT AND PRESSURE; ALLOW TIME FOR PUMP TO COOL TO ROOM TEMPERATURE BEFORE HANDLING OR SERVICING.

F-1) Lubrication:

Anytime the pump is removed from operation and at least every twelve (12) months, the cooling oil in the motor housing (12) must be checked visually for oil level and contamination.

F-1.1) Checking Oil:

To check oil, set unit upright. Remove pipe plug (21). With a flashlight, visually inspect the oil in the motor housing (12) to make sure it is clean, clear and that the oil level is above all internal componentry . If oil appears satisfactory, replace pipe plug. If oil is low or appears contaminated, test oil as per section F-1.2

F-1.2) Testing Oil:

1. Place pump on it's side, remove pipe plug (21) and drain oil into a clean, dry container.
2. Check oil for contamination using an oil tester with a range to 30 kilovolts breakdown.
3. If oil is found to be clean and uncontaminated (measures above 15 KV. breakdown), refill the motor housing as per section F-1.3.
4. If oil is found to be dirty or contaminated (or measures below 15KV. breakdown), then the pump must be carefully inspected for leaks at the shaft seal (3), cord inlet (8), square ring (11), and pipe plug (21) before refilling with oil. To locate the leak, perform a pressure test as per section F-1.4. After leak is repaired, refill with new oil as per section F-1.3.

Table 1

| COOLING OIL- Dielectric | |
|--------------------------------|------------------|
| Supplier | Grade |
| BP | Enerpar SE40 |
| Conoco | Pale Paraffin 22 |
| Mobil | D.T.E. Oil Light |
| G & G | Circulating 22 |

F-1.3 Replacing Oil in Motor Housing:

Drain all oil from motor housing and dispose of properly. Refill with (see parts list for amount) new cooling oil as per table 1. An air space must remain in the top of the motor housing to compensate for air expansion (see Fig. 8). Set unit upright and fill only until the capacitor, or the motor for 3-phase, as viewed through the fill plug hole is covered. When refilling with oil after servicing the shaft seal (3), a pressure test as per section F-1.4 should be done. If shaft seal was not disturbed during service, then apply pipe sealant and replace the pipe plug (21).

WARNING !
DO NOT OVERFILL OIL
Overfilling of motor housing with oil can create excessive and dangerous hydraulic pressure which can destroy the pump and create a hazard.
Overfilling oil voids warranty.

F-1.4) Pressure Test:

Before checking the pump for leaks around the shaft seal, square ring, and cord inlet, the oil level should be full as described in section F1.3. Apply pipe sealant to the pressure gauge assembly and tighten into fill plug hole (see fig.4). Pressurize motor housing to 10 P.S.I. Use a soap solution around the sealed areas and inspect joints for "air bubbles".

If, after five minutes, the pressure is still holding constant, and no "bubbles" are observed, slowly bleed the pressure and remove the gauge assembly. Replace the pipe plug using a sealant. If the pressure does not hold, then the leak must be located.

**CAUTION:
ALWAYS WEAR EYE
PROTECTION WHEN WORKING
ON PUMPS.**

**CAUTION:
PRESSURE BUILDS UP
EXTREMELY FAST; INCREASE
PRESSURE BY "TAPPING" AIR
NOZZLE. TOO MUCH PRESSURE
WILL DAMAGE SEAL. DO NOT
EXCEED 10 P.S.I.**

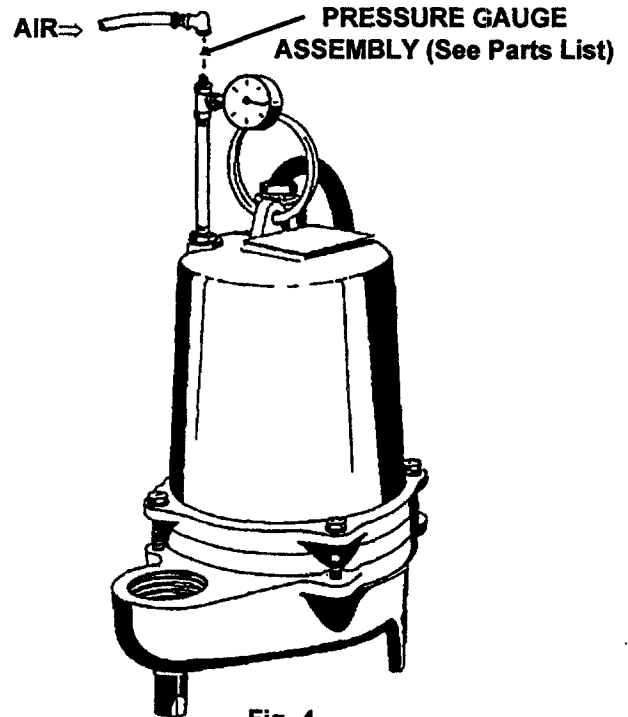

F-2) Impeller and Volute Service:

F-2.1) Disassembly and Inspection:

To clean out body (18), or to replace impeller (15), disconnect power, remove hex bolts (13), and vertically lift motor and seal assembly from body (18). Clean out body if necessary. Clean and examine impeller (15) for pitting or wear and replace if required. Inspect gasket (17) and replace if cut or damaged. If the impeller (15) needs replacing, remove nut (16). The impeller is threaded onto the shaft and to remove, unscrew impeller holding shaft with a large screwdriver. Remove exclusion seal (14) and replace if needed.

F-2.2) Reassembly:

Before installing impeller (15), inspect threads on shaft and impeller to assure that they are clean. Place exclusion seal on shaft with the thin lip towards the motor (see section F-4.3). Screw impeller onto shaft and tighten. Apply a thread-locking compound to shaft threads, thread nut on and torque to 30 ft. lbs. Rotate impeller to check for binding. Position gasket (17) on body and install impeller and motor housing on pump body. Apply thread locking compound to each cap screw, thread into body, and torque to 8 ft.lbs. Check for free rotation of impeller.

F-3) Motor and Bearing Service

F-3.1) Disassembly and Inspection:

Motor - To examine or replace the motor (1) or bearings (4), remove body and impeller as per section F-2.1. Drain oil from motor housing as per section F-1.2. Remove socket head screws (13). Loosen gland nut (8a) (see Fig. 5), and push cord through while lifting motor housing (12) off of seal plate (2). Disconnect motor wires from cord set (8).

Pull cord (8) through motor housing and inspect grommet (8c) (Fig. 5) for deterioration. Remove square ring (11) and inspect for breaks. Loosen motor screws and pull motor (1) straight up and off seal plate (2). Inspect all parts for signs of wear.

Bearings - Disassemble motor as per section F-3.1. Remove snap ring (5) with snap ring pliers and pull motor (1) and lower bearing (4) straight off of seal plate (2). Inspect all parts for signs of wear and replace as needed.

CAUTION:
HANDLE SEAL PARTS WITH EXTREME CARE. DO NOT SCRATCH OR MAR LAPPED SURFACES.

F-3.2) Replacing Bearings:

When replacing bearings, be careful to not damage the rotor or shaft threads. Press the old bearings off the shaft with an arbor press or gear puller. Clean the shaft thoroughly. Apply adhesive compound to shaft and press new bearing on, pushing only on the inner race, until it seats against shoulder of shaft (see fig.8)

IMPORTANT:
ALL PARTS MUST BE CLEAN BEFORE REASSEMBLY.

F-3.3) Reassembly:

Make sure shaft seal (3) is clean and in proper position as per section F-4.2 before reassembling rotor and bearing. Slide lower bearing and rotor shaft squarely into the seal plate (2) until bearing seats on the bottom. Insert snap ring (5) into seal plate with flat edge against outer race of bearing. Place motor stator squarely onto seal plate and tighten motor screws. Install square ring squarely (11) onto seal plate. With cord assembly (8) properly assembled, slip cord through motor housing (see Fig. 5). Connect motor wires to cord set as per figure 5 & 6. Place motor housing squarely onto seal plate while pulling excess cord through hole. Tighten socket head screws (13) into motor housing. Tighten gland nut (8a) against washers (8b) and grommet (8c). Refill with cooling oil as per paragraph F-1.3.

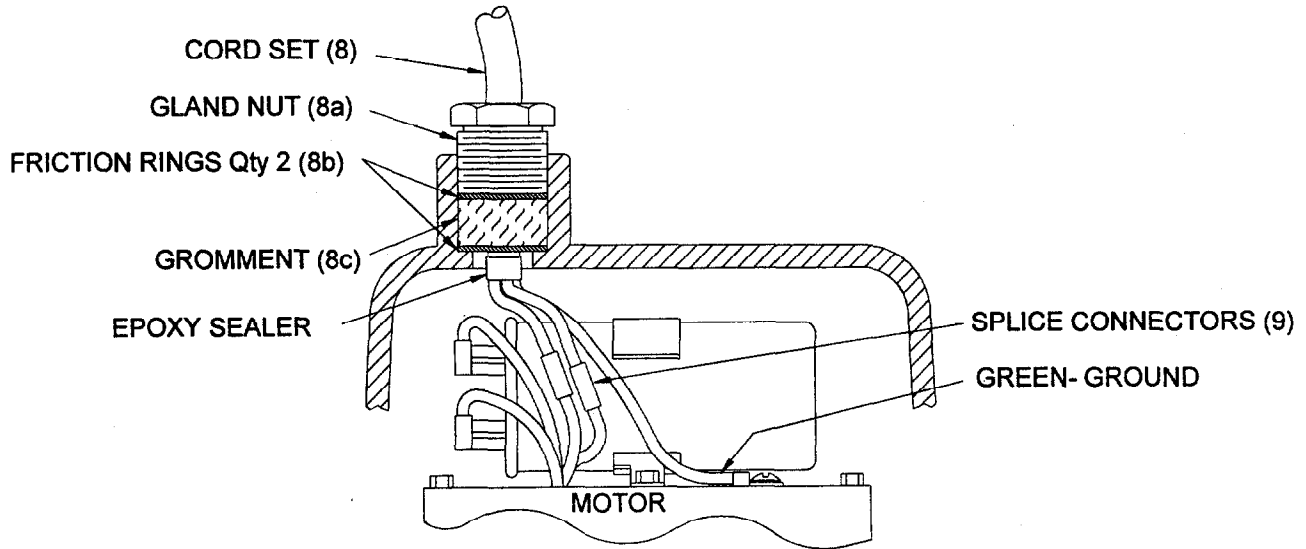

Fig. 5

SINGLE PHASE-115 & 230 VAC

POWER CABLE

Green (Ground)
Black
White
Flag Connector
Flag Connector

MOTOR LEADS

Green
Straight Connector
Straight Connector
Capacitor
Capacitor

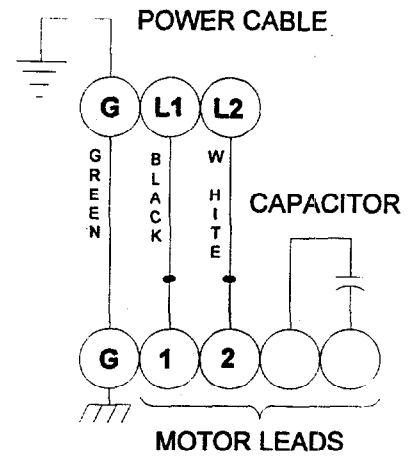

THREE PHASE, 200/230 VOLT AC

Power Cable (30)

Green (Ground)
Black
Red
White

Motor Lead Number

Green
1 & 7
2 & 8
3 & 9
4, 5 & 6 Together

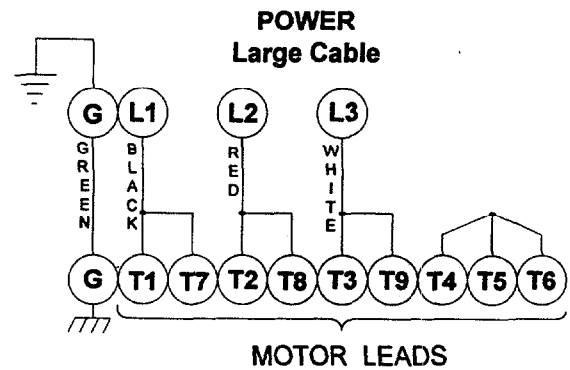

THREE PHASE, 460 & 575 VOLT AC

Power Cable (30)

Green (Ground)
Black
Red
White

Motor Lead Number

Green
1
2
3
4 & 7 Together
5 & 8 Together
6 & 9 Together

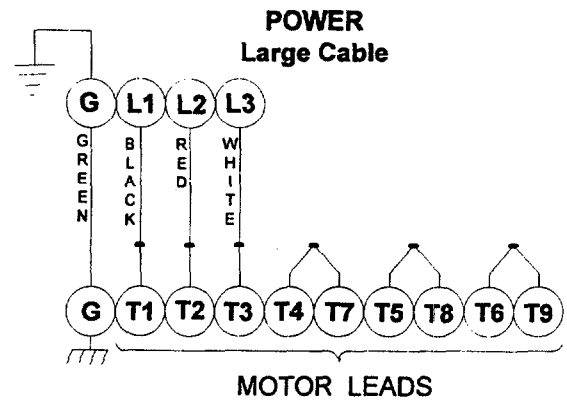

Fig. 6

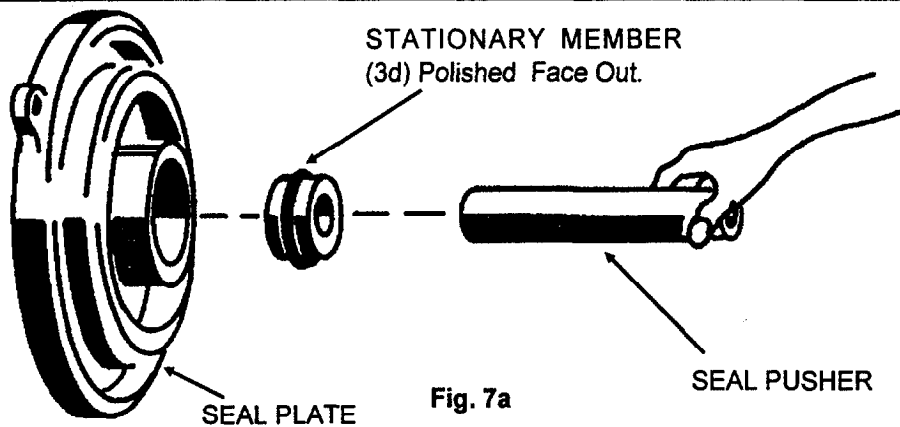

Fig. 7a

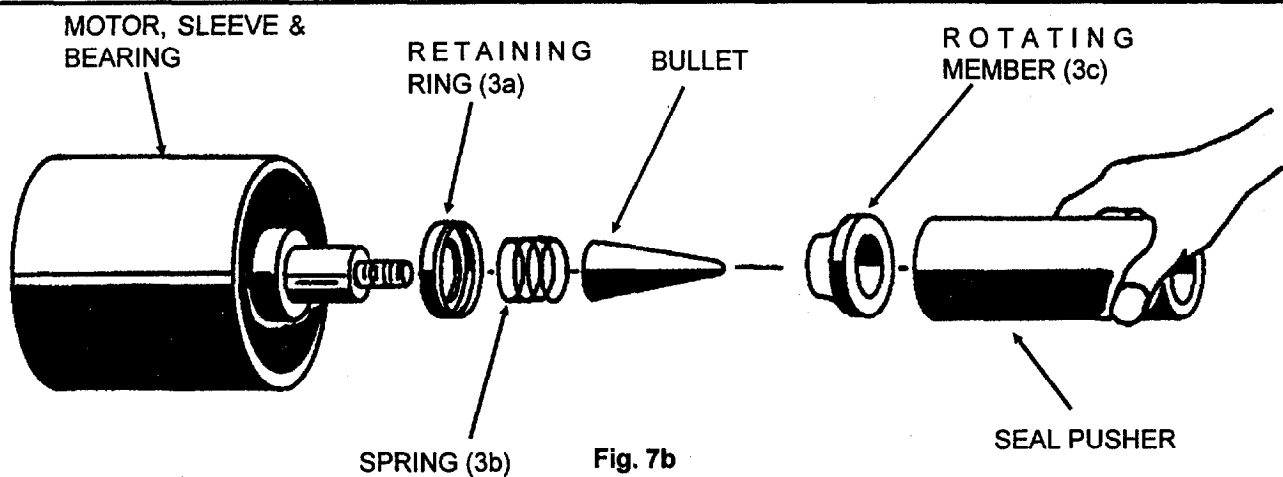

Fig. 7b

F-4) Shaft Seal Service

F-4.1) Disassembly and Inspection:

Disassemble pump motor as per section F-3.1. Inspect seal for signs of wear such as uneven wear pattern on the stationary member or chips and scratches on either sealing face. Do not interchange seal components. Replace entire seal if damage occurs.

F-4.2) Replacing Shaft Seal (refer to fig. 7 & 8):

When replacing the shaft seal (3), remove used rotating member (3c), spring (3b), and spring retainer (3a) from motor shaft. Press used stationary member (3d) from the seal plate (2). At reassembly, clean seal cavity thoroughly and apply a light coat of oil. Lightly oil the rubber ring (**DO NOT** use grease) and press the stationary member firmly into the seal plate using a seal pusher (See Parts List- Seal Tool Kit), nothing but pusher to come in contact with seal face (see Fig. 7a).

Insert so that the finished surface is up and the grooved surface is against the seal plate. Make sure the stationary member is in straight and that the rubber ring is not out of it's groove.

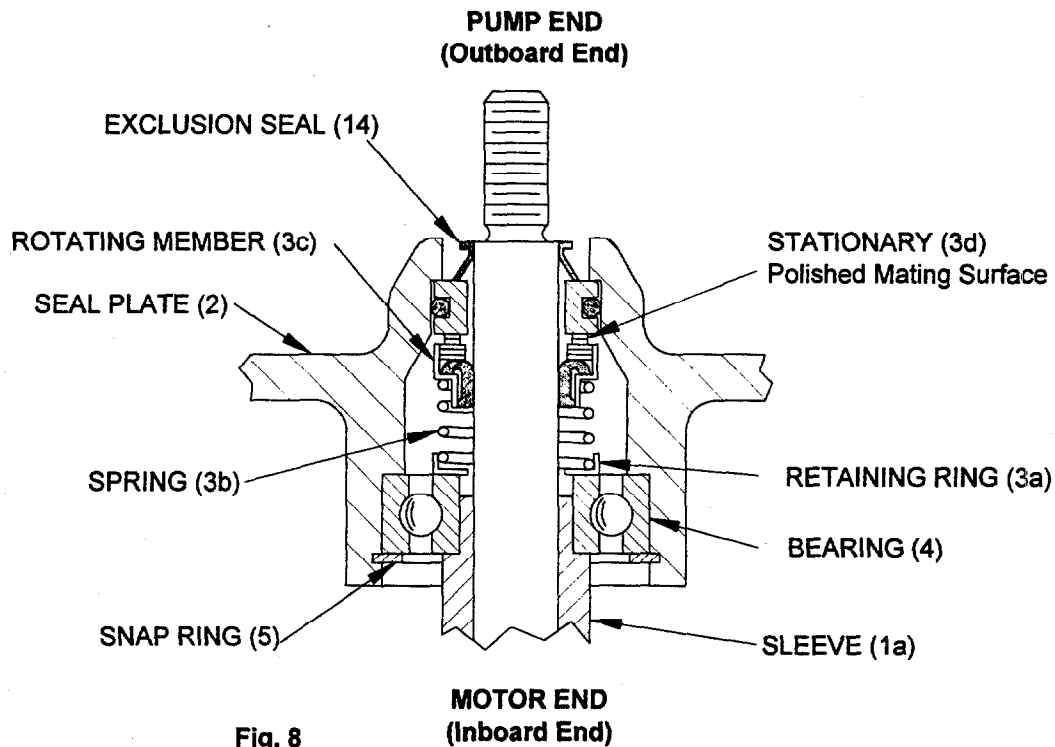

Fig. 8

DO NOT HAMMER ON THE SEAL PUSHER - IT WILL DAMAGE THE SEAL FACE. Place spring retainer and spring onto motor shaft. Lightly oil shaft (**DO NOT** use grease) and inner surface of bellows of rotating member. With finished end away from motor, slide rotating member over bullet and onto shaft until it engages spring (see Fig. 7b). Carefully assemble shaft to seal plate as per section F-3.3. It is extremely important to keep seal faces clean during assembly. Dirt particles lodged between these faces will cause the seal to leak. When seal plate is assembled to motor, it will properly align and seat the seal (3) and bearing (4). Follow complete reassembly instructions as per section F-3.3.

F-4.3) Replacing Exclusion Seal:

The exclusion seal (14), helps to keep debris away from the shaft seal where it could cause damage. The exclusion seal should be replaced whenever the shaft seal is replaced. To replace the exclusion seal, pull the old seal off the shaft, and slide the new seal on with the thin lip towards the motor. Be sure not to damage the lip of the seal. Finger pressure is all that is needed to install the exclusion seal.

TROUBLE SHOOTING

CAUTION ! Always disconnect the pump from the electrical power source before handling.

If the system fails to operate properly, carefully read instructions and perform maintenance recommendations. If operating problems persist, the following chart may be of assistance in identifying and correcting them: **MATCH "CAUSE" NUMBER WITH CORRELATING "CORRECTION" NUMBER.**

| PROBLEM | CAUSE | CORRECTION |
|-------------------------------------|---|---|
| Pump will not run | <ol style="list-style-type: none"> 1. Poor electrical connection, blown fuse, tripped breaker or other interruption of power; improper power supply. 2. Motor or switch inoperative (to isolate cause, go to manual operation of pump). <ol style="list-style-type: none"> 2a. Float movement restricted 2b. Switch will not activate pump or is defective. 2c. Defective motor. 3. Insufficient liquid level. | <ol style="list-style-type: none"> 1. Check all electrical connections for security. Have electrician measure current in motor leads, if current is within $\pm 20\%$ of locked rotor Amps, impeller is probably locked. If current is 0, overload may be tripped. Remove power, allow pump to cool, then recheck current. 2a. Reposition pump or clean basin as required to provide adequate clearance for float. |
| Pump will not turn off | <ol style="list-style-type: none"> 2a. Float switch movement restricted. 2b. Switch will not de-activate pump or is defective. 4. Excessive inflow or pump not properly sized for application. 9. Pump may be airlocked. 14. Switch is in "HAND" position. | <ol style="list-style-type: none"> 2b. Disconnect level control. Set ohmmeter for a low range, such as 100 ohms full scale and connect to level control leads. Actuate level control manually and check to see that ohmmeter shows zero ohms for closed switch and full scale for open switch. |
| Pump hums but doesn't run | <ol style="list-style-type: none"> 1. Incorrect voltage. 8. Impeller jammed or loose shaft, worn or damaged, impeller cavity or inlet plugged. | <ol style="list-style-type: none"> 2c. Replace per servicing instructions. |
| Pump delivers insufficient capacity | <ol style="list-style-type: none"> 1. Incorrect voltage. 4. Excessive inflow or pump not properly sized for application. 5. Discharge restricted. 6. Check valve stuck closed or installed backwards. 7. Shut-off valve closed. 8. Impeller jammed, loose on shaft, worn or damaged, impeller cavity or inlet plugged. 9. Pump may be airlocked. 10. Pump running backwards. | <ol style="list-style-type: none"> 3. Make sure liquid level is at least equal to suggested turn-on point. 4. Recheck all sizing calculations to determine proper pump size. 5. Check discharge line for restrictions, including ice if line passes through or into cold areas. |

TROUBLE SHOOTING

| PROBLEM | CAUSE | CORRECTION |
|--|--|---|
| <p>Pump cycles too frequently or runs periodically when fixtures are not in use.</p> | <p>6. Check valve not installed or leaking back into basin. 11. Fixtures are leaking. 15. Ground water entering basin.</p> | <p>6. Remove and examine check valve for proper installation and freedom of operation.</p> |
| <p>Pump shuts off and turns on independent of switch. (trips thermal overload protector). CAUTION ! Pump may start unexpectedly. Disconnect power supply.</p> | <p>1. Improper wiring or power supply. 4. Discharge head less than minimum. 8. Impeller jammed or rubbing. 12. Excessive water temperature (internal protection only).</p> | <p>7. Open valve.</p> <p>8. Check impeller for freedom of operation, security and condition. Clean impeller cavity and inlet of any obstruction.</p> <p>9. Loosen union slightly to allow trapped air to escape. Verify that turn-off level of switch is set so that impeller cavity is always flooded. Clean vent hole.</p> |
| <p>Pump operates noisily or vibrates excessively.</p> | <p>2c. Worn bearings, motor shaft bent. 8. Debris in impeller cavity or broken impeller. 10. Pump running backwards. 13. Piping attachments to building structure too rigid or too loose.</p> | <p>10. Check rotation. If power supply is three phase, reverse any two of three power supply leads to ensure proper impeller rotation.</p> <p>11. Repair fixtures as required to eliminate leakage.</p> <p>12. Check pump temperature limits & fluid temperature.</p> <p>13. Replace portion of discharge pipe with flexible connector.</p> <p>14. Turn to automatic position.</p> <p>15. Check for leaks around basin inlet and outlets.</p> |

SECTION: F REPLACEMENT PARTS

F-1 ORDERING REPLACEMENT PARTS:

When ordering replacement parts, **ALWAYS** furnish the following information:

1. Pump serial number and date code. (F-4)
2. Pump model number. (F-3)
3. Pump part number.(F-2)
4. Part description.
5. Item part number.
6. Quantity required.
7. Shipping instructions.
8. Billing instructions.

The diagram shows a rectangular nameplate for a Barnes pump. At the top center is the word "BARNES" with a registered trademark symbol. Below it are three main fields: "Model No." on the left, "Part No." on the right, and "Serial No." in a larger box below them. To the left of the "Model No." field is a circled number "2" with an arrow pointing to it. To the right of the "Part No." field is a circled number "3" with an arrow pointing to it. To the right of the "Serial No." field is a circled number "1" with an arrow pointing to it. Below these fields are several smaller boxes for technical specifications: "HP", "Volts", "Ph.", "Hz.", "Code" in a row; and "Amps", "RPM", "Impeller Dia." in a row below that. On the left side of the nameplate, the number "06880" is printed vertically. At the bottom of the nameplate, there is a warning in English and French: "USE WITH APPROVED MOTOR CONTROL THAT MATCHES MOTOR INPUT IN FULL LOAD AMPERES. (UTILISER UN DEMARREUR APPROUVE COVENANT AU COURANT A PLEINE CHARGE DU MOTOR.)". To the right of this text is the company name "BARNES PUMPS, INC. Mansfield, Ohio" and a logo.

F-2 PART NUMBER:

The part number consist of a six (6) digit number, which appears in the catalog. A one or two letter suffix may follow this number to designate the design configuration. This number is used for ordering and obtaining information.

F-3 MODEL NUMBER:

This designation consist of numbers and letters which represents the discharge size, series horsepower, motor phase and voltage, speed and pump design. This number is used for ordering and obtaining information.

F-4 SERIAL NUMBER:

The Serial Number consist of a ten digit number, which is specific to each pump. The first six digits are the pumps individual identity and the last four digits are the date the units was built. Example: 0056750490; 005675=Identity Number, 0490=Date Code (April of 1990).

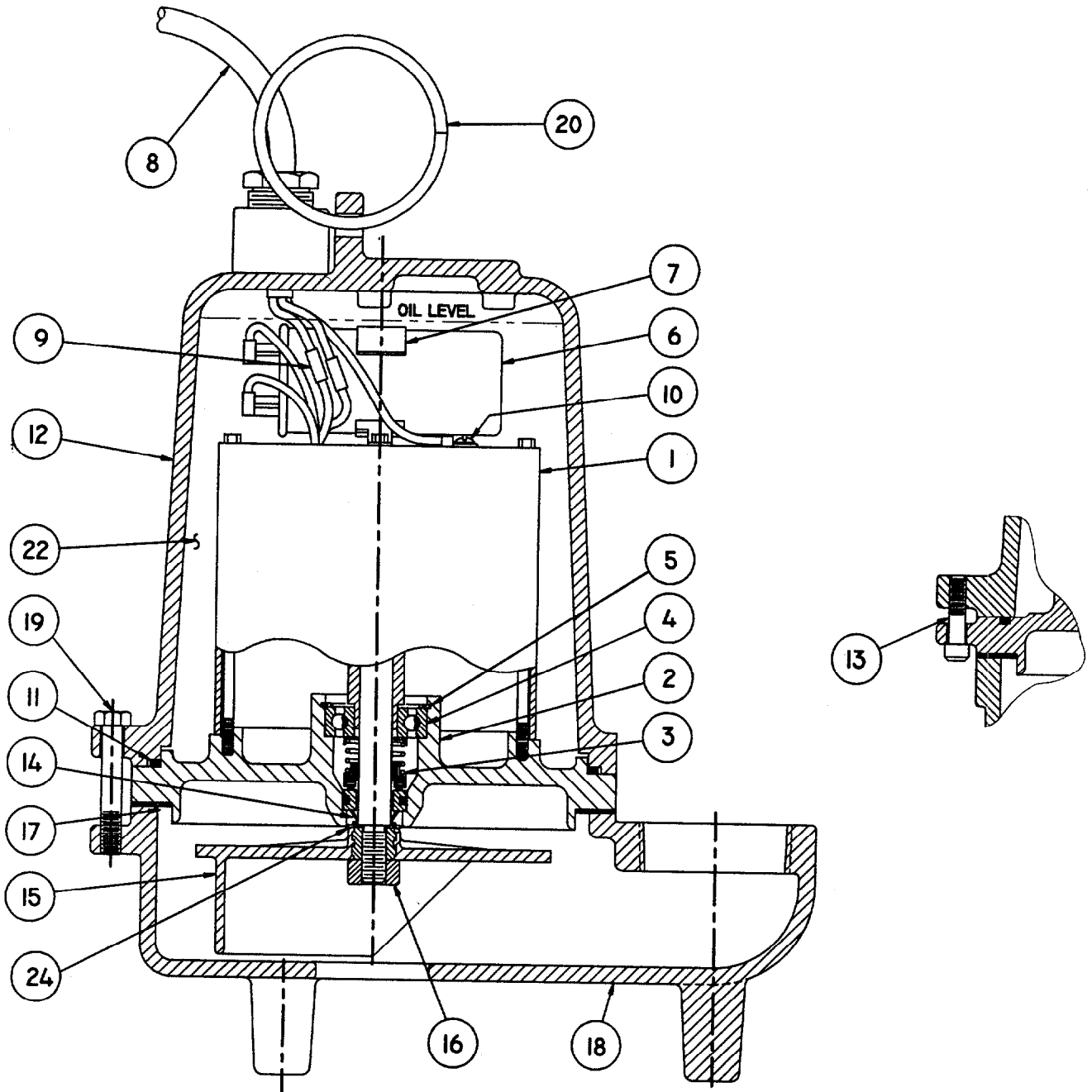

Fig. 9

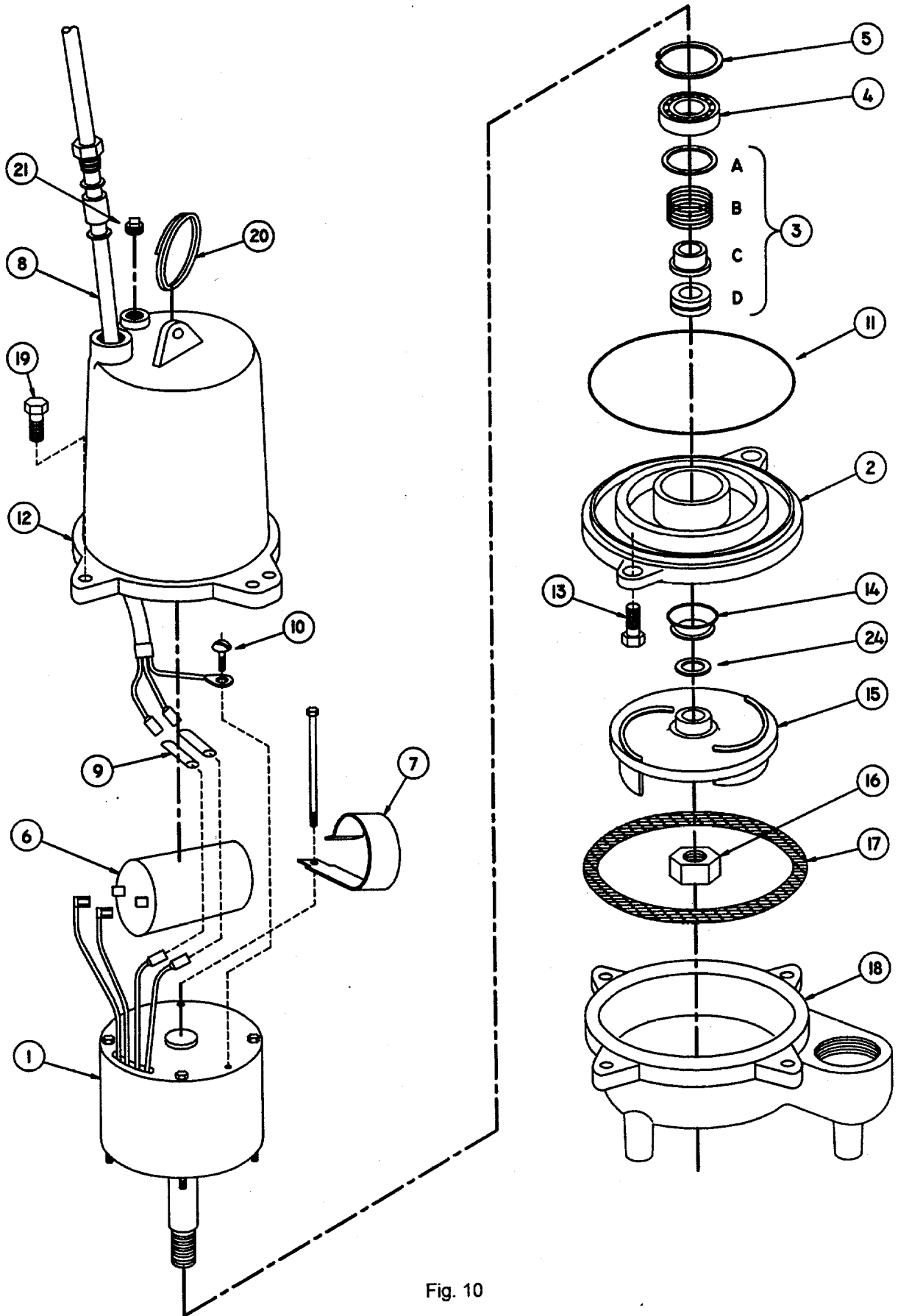

Fig. 10

PARTS LIST

| ITEM | QTY | DESCRIPTION | PART No. |
|------|-----|-------------------------------|--|
| 1 | 1 | Motor | SE514L . 030369 SE524L 029792 SE594L, SE544L 071354 SE554L 071354F SE1024L 029792 SE1094L, SE1044L 071354 SE1054L 071354F SE512L 068926 SE522L 068927 SE532L, SE542L 067462 SE552L 088548 SE1022L 068928 SE1032L, SE1042L 071355 SE1052L 067463F |
| 2 | 1 | Seal Plate | 093067 |
| 3 | 1 | Shaft Seal, (Standard) | Carbon/Ceramic/Buna-N 088572 |
| 4 | 1 | Bearing | 017414 |
| 5 | 1 | Snap Ring | 017415 |
| 6 | 1 | Capacitor (Single phase only) | 370V 20MFD 070963 |
| 7 | 1 | Capacitor Bracket | 039858 |
| 8 | 1 | Power Cable Assembly | 115V, 1 Phase 062328 |
| | | Power Cable Assembly | 230V, 1 Phase 062328D |
| | | Power Cable Assembly | 3 Phase 051545 |
| 8a | 1 | * Gland Nut | 1-16 Stainless 051448 |
| 8b | 2 | * Friction Ring | 051449 |
| 8c | 1 | * Grommet | 051451 |
| 9 | 2 | Connector, Terminal | 1 Phase 026880 |
| | 3 | Connector, Terminal | 3 Phase 071363 |
| 10 | 1 | Self Tapping Screw | 6-32 x 1/4 lg Stainless 22-24-6 |
| 11 | 1 | Square Ring | 019289 |
| 12 | 1 | Motor Housing | 093068 |
| 13 | 2 | Socket Hd. Cap Screw | 1/4-20x 1" Stainless 018923 |
| 14 | 1 | Exclusion Seal | 056789 |
| 15 | 1 | Impeller, Cast Iron | 1750RPM MODELS: 5.38" Dia. (Std .5HP) 088637 6.25" Dia. (Std. 1HP) 088638 3450RPM MODELS: 3.88" Dia.(Std 1HP) 088636 3.75" Dia. 088636TA 3.62" Dia. (Std .5HP) 088636TB 3.50" Dia. 088636TC 3.38" Dia. 088636TD 3.25" Dia. 088636TE 3.12" Dia. 088636TF 3.00" Dia. 088636TG |
| 16 | 1 | Nut | 1/2-20 Stainless 030068 |
| 17 | 1 | Gasket | 068984 |
| 18 | 1 | Volute, | 089120 |
| 19 | 4 | Cap Screw | 5/16-18 x 1-3/4" Stainless 1-135-1 |

* Included with Item 8

| ITEM | QTY | DESCRIPTION | PART No. |
|------|-------|---|----------|
| 20 | 1 | Handle | 027271 |
| 21 | 1 | Pipe Plug (Not Shown on Fig. 9) | 085132 |
| 22 | 3 qt. | Oil | 029034 |
| 23 | 1 | Terminal Boot (Not Shown) | 034322 |
| 24 | 1 | Spacer | 059648 |
| 25 | 3 | Wire Nut (Not Shown) 3 Phase | 019212 |

IMPORTANT ! WARRANTY REGISTRATION

Your pump is covered by the enclosed Warranty. This warranty is **ONLY** effective provided the warranty registration is completed and returned to the Barnes® Pumps, Inc. service department.

IMPORTANT! If you have a claim under the provision of the warranty, contact your local Barnes Pumps, Inc. Distributor.

RETURNED GOODS POLICY

**RETURN OF MERCHANDISE REQUIRES A "RETURNED GOODS AUTHORIZATION".
CALL THE FACTORY SERVICE MANAGER, (513) 773-2442 FOR RGA NUMBER.**

RETURN OF EQUIPMENT: No equipment shall be returned to us without first obtaining a written Returned Goods Authorization and shipping instructions from us. The returner must prepay the charges in full for transportation to our factory. Credit allowed for new, undamaged equipment of current standard design will be 80% of the invoiced price or current billing price, whichever is less. Equipment which has been used, however slight, will not be accepted.

Authorization will not be given for return of equipment,

- (1) which would, in our opinion, result in an excess in the amount of stock we normally carry,
- (2) not invoiced within the last 12 months, or
- (3) which is non-standard and manufactured specifically to a buyer's specifications. For non-standard equipment not of our manufacture, the only credit allowed will be such credit as may be allowed by the manufacturer of such equipment.

Equipment must be returned within 30 days of the issuance of the Returned Goods Authorization. No item with a net value of less than \$35.00 will be authorized for return. Unauthorized returns may be refused and/or returned freight collect.

BARNES[®]

Limited Warranty

We warrant to our immediate customer and to the ultimate consumer that products of our manufacture will be free of defects in material and workmanship under normal use and service for the following time periods, when installed and maintained in accordance with our instructions.

Pump Products: One (1) year from date of installation or (24) twenty-four months from date of shipment, whichever occurs first. Cleaning Products: Twelve (12) months from date of installation or eighteen (18) months from date of shipment, whichever occurs first. As used herein, "the ultimate consumer" is defined as the purchaser who first uses the product after its initial installation or, in the case of product designed for non permanent installation, the first owner who used the product. It is the purchaser's or any sub-vendee's obligation to make known to the ultimate consumer the terms and conditions of this warranty. This warranty gives you specific legal rights, and there may also be other rights which vary from state to state. In the event the product is covered by the Federal Consumer Product Warranties Law (1) the duration of any implied warranties associated with the product by virtue of said law is limited to the same duration as stated herein, (2) this warranty is a LIMITED WARRANTY, and (3) no claims of any nature whatsoever shall be made against us, until the ultimate consumer, his successor, or assigns, notifies us in writing of the defect, and delivers the product and/or defective part(s) freight prepaid to our factory or nearest authorized service station. Some states do not allow limitations on how long an implied warranty lasts, so the above limitation may not apply. **THE SOLE AND EXCLUSIVE REMEDY FOR BREACH OF ANY AND ALL WARRANTIES WITH RESPECT TO ANY PRODUCT SHALL BE TO REPLACE OR REPAIR AT OUR ELECTION, F.O.B. POINT OF MANUFACTURE OR AUTHORIZED REPAIR STATION, SUCH PRODUCTS AND/OR PARTS AS PROVEN DEFECTIVE. THERE SHALL BE NO FURTHER LIABILITY, WHETHER BASED ON WARRANTY, NEGLIGENCE OR OTHERWISE.** Unless expressly stated otherwise, guarantees in the nature of performance specifications furnished in addition to the foregoing material and workmanship warranties on a product manufactured by us, if any, are subject to laboratory tests corrected for field performance. Any additional guarantees, in the nature of performance specifications must be in writing and such writing must be signed by our authorized representative. Due to inaccuracies in field testing if a conflict arises between the results of field testing conducted by or for user, and laboratory tests corrected for field performance, the latter shall control. Components or accessories supplied by us but manufactured by others are warranted only to the extent of and by the terms and conditions of the original manufacturer's warranty. **RECOMMENDATIONS FOR SPECIAL APPLICATIONS OR THOSE RESULTING FROM SYSTEMS ANALYSES AND EVALUATIONS WE CONDUCT WILL BE BASED ON OUR BEST AVAILABLE EXPERIENCE AND PUBLISHED INDUSTRY INFORMATION. SUCH RECOMMENDATIONS DO NOT CONSTITUTE A WARRANTY OF SATISFACTORY PERFORMANCE AND NO SUCH WARRANTY IS GIVEN.**

This warranty shall not apply when damage is caused by (a) improper installation, (b) improper voltage (c) lightning (d) sand or other abrasive material (e) scale or corrosion build-up due to excessive chemical content. Any modification of the original equipment will also void the warranty. We will not be responsible for loss, damage or labor cost due to interruption of service caused by defective parts. Neither will we accept charges incurred by others without our prior written approval.

This warranty is void if our inspection reveals the product was used in a manner inconsistent with normal industry practice and/or our specific recommendations. The purchaser is responsible for communication of all necessary information regarding the application and use of the product. **UNDER NO CIRCUMSTANCES WILL WE BE RESPONSIBLE FOR ANY OTHER DIRECT OR CONSEQUENTIAL DAMAGES, INCLUDING BUT NOT LIMITED TO LOST PROFITS, LOST INCOME, LABOR CHARGES, DELAYS IN PRODUCTION, IDLE PRODUCTION, WHICH DAMAGES ARE CAUSED BY ANY DEFECTS IN MATERIAL AND/OR WORKMANSHIP AND/OR DAMAGE OR DELAYS IN SHIPMENT. THIS WARRANTY IS EXPRESSLY IN LIEU OF ANY OTHER EXPRESS OR IMPLIED WARRANTY, INCLUDING ANY WARRANTY OF MERCHANTABILITY OR FITNESS FOR A PARTICULAR PURPOSE.**

No rights extended under this warranty shall be assigned to any other person, whether by operation of law or otherwise, without our prior written approval.

START-UP REPORT FOR SUBMERSIBLE PUMPS

This report is designed to insure the customer that customer service and a quality product are the number one priority with Barnes® Pumps, Inc. Please answer the following questions completely and as accurately as possible. Mail this form to:

**BARNES PUMPS, INC.
PARTS & SERVICE DEPT.
420 THIRD ST.
P.O. BOX 603
PIQUA, OHIO 45356-0603 U.S.A.
ATTN: SERVICE MANAGER**

REPORTS THAT ARE NOT RETURNED CAN DELAY OR VOID WARRANTY.

- 1) Pump Owner's Name _____
Address _____
Location of Installation _____
Person in Charge _____ Phone _____
Purchased From (Barnes Pumps' Representative/Distributor) _____
- 2) Barnes Pumps Model _____ Serial No. _____
Part Number _____
Voltage _____ Phase _____ Hertz _____ Horespower _____
Rotation: Direction of Impeller Rotation (Use C/W for clockwise, CC/W for counter-clockwise) _____
Method Used to Check Rotation (viewed from bottom) _____
Does Impeller Turn Freely By Hand _____ YES _____ NO
- 3) Condition Of Equipment _____ GOOD _____ FAIR _____ POOR
Condition Of Cable Jacket _____ GOOD _____ FAIR _____ POOR
Resistance of Cable Jacket _____ GOOD _____ FAIR _____ POOR
Resistance of Cable and Pump Motor (measured at pump control)
Red-Black _____ Ohms, Red-White _____ Ohms, White-Black _____ Ohms
Resistance Of Ground Circuit Between Control Panel and Outside of Pump _____ Ohms
MEG Ohms Check of Insulation:
Red to Ground _____ White to Ground _____ Black to Ground _____
- 4) Condition of Equipment At Start-Up: Dry _____ Wet _____ Muddy _____
Was Equipment Stored: _____ Length of Storage: _____
Describe Station Layout _____
- 5) Liquid Being Pumped _____
Debris In Bottom of Station? _____
Was Debris Removed In Your Presence? _____
Are Guide Rails Exactly Vertical? _____
Is BAF Stationary Installed Level? _____
- 6) Liquid Level Controls: Model _____
Is Control Installed Away From Turbulence _____
Operation Check:
Tip Lowest Float (stop float), All Pumps Should Remain Off.
Tip Second Float (and stop float), One Pump Comes On.
Tip Third Float (and stop float), Both Pumps On (alarm on simplex).
Tip Fourth Float (and stop float), High Level Alarm On (omit on simplex).
- If not Barnes level controls, describe type of controls _____
Does liquid level ever drop below volute top? _____

7) Barnes Pumps Control Panel Part No. _____
Number of Pumps Operated By Control Panel _____

NOTE: At no time should holes be made in top of control panel, unless proper sealing devices are utilized.

Control Panel Manufactured By Others: _____

Company Name _____

Model No. _____

Short Circuit Protection _____ Type _____

Number and Size of Short Circuit Device(s) _____ Amp Rating _____

Overload Type _____ Size _____ Amp Rating _____

Do Protective Devices Comply With Pump and Motor Amp Rating _____

Are All Connections Tight? _____

Is The Interior of The Panel Dry? _____

8) Electrical Readings:

Single Phase:

Voltage Supply at Panel Line Connection, Pump Off, L1, L2 _____

Voltage Supply at Panel Line Connection, Pump On, L1, L2 _____

Amperage: Load Connection, Pump On, L1 _____ L2 _____

Three Phase:

Voltage Supply at Panel Line Connection, Pump Off, L1-L2 _____ L2-L3 _____ L3-L1 _____

Voltage Supply at Panel Line Connection, Pump On, L1-L2 _____ L2-L3 _____ L3-L1 _____

Amperage, Load Connection, Pump On, L1 _____ L2 _____ L3 _____

9) Final Check:

Is Pump Seated On Discharge Properly? _____ Check for Leaks? _____

Does Check Valves Operate Properly? _____

Flow; Does Station Appear To Operate At Proper Rate _____ Pump Down Time _____

Noise Level: High _____ Medium _____ Low _____

Comments: _____

10) Equipment Difficulties During Start-Up: _____

11) Manuals:

Has Operator Received Pump Instructions and Parts Manual? _____

Has Operator Received Electrical Control Panel Diagram? _____

Has Operator Been Briefed On Warranty? _____

Address of Local Barnes Pumps Representative/Distributor _____

12) I Have Received The Above Information (Name of Operator) _____

Name of Company _____

Date _____

I Certify This Report To Be Accurate (Name of Start-Up Person) _____

(Employed By) _____

Date _____

Date and Time of Start-Up _____

Present At Start-Up:

() Engineer _____ () Operator _____

() Contractor _____ () Other _____

**IMPORTANT !
WARRANTY REGISTRATION**

Your pump is covered by the enclosed Warranty. This warranty is **ONLY** effective provided the warranty registration is completed and returned to the Barnes Pumps, Inc. service department. Review the form below and fill in all information.

IMPORTANT! If you have a claim under the provision of the warranty, contact your local Barnes Pumps, Inc. Distributor.

FOLD HERE

**** IMPORTANT ! ****

THIS FORM MUST BE RETURNED TO VALIDATE THE WARRANTY

WARRANTY REGISTRATION

CUSTOMER'S NAME _____ DATE INSTALLED _____

ADDRESS _____

CITY _____ STATE _____ ZIP _____

PHONE # _____ FAX # _____

DEALER'S NAME _____

CITY _____ STATE _____ ZIP _____

PUMP MODEL NO. _____ SERIAL NO. _____ VOLTAGE _____

PART NO. _____

FOLD HERE AND TAPE, DO NOT STAPLE

PLACE
STAMP
HERE

**BARNES PUMPS, INC.
SERVICE DEPARTMENT
420 THIRD STREET
P.O. BOX 603
PIQUA, OHIO
45356-0603 - U.S.A.**

APPENDIX H

SECTION 3



JET MIXING EQUIPMENT
CAMP LE JEUNE
NORTH CAROLINA, U.S.A.

ECO PROJECT: 94-3453

JOB NO.: 1002448

SPECIFICATIONS

| SUBMITTAL REVIEW | |
|---|---|
| REVIEW IS FOR GENERAL COMPLIANCE WITH CONTRACT DOCUMENTS. NO RESPONSIBILITY IS ASSUMED FOR CORRECTNESS OF DIMENSIONS OR DETAILS. THE CONTRACTOR/SUPPLIER SHALL ASSUME FULL RESPONSIBILITY FOR DEVIATIONS FROM CONTRACT REQUIREMENTS NOT SPECIFICALLY INDICATED ON THIS SUBMITTAL. | |
| <input checked="" type="checkbox"/> NO EXCEPTIONS | <input type="checkbox"/> HAVE CORRECTIONS NOTED |
| <input type="checkbox"/> AMEND AND RESUBMIT | <input type="checkbox"/> REJECTED - SEE REMARKS |
| Date: <u>5-10-95</u> BY: <u>B. MATTHEWS</u> | |
| OHM REMEDIATION SERVICES CORP. NORCROSS, GEORGIA | |

OHM Remediation Services Corp.
5335 Triangle Parkway, Suite 450
Norcross, Georgia
U.S.A.
30092

MAY 1995

3330 DES ENTREPRISES BLVD.
TERREBONNE, QUÉBEC J6X 4J8

TEL.: (514) 477-7879
FAX: (514) 477-7880

**TECHNICAL DATA SHEET
CAMP LE JEUNE
JET MIXING EQUIPMENT**

General System Description:

The system consists of one (1) bidirectional jet mixing, Eco Jet Mixing header, including jet mixing, dry pit solids-handling pump and accessories.

Tank Dimensions:

| | |
|----------------------------|-----------|
| Diameter: | 12 feet |
| Height: | 26 feet |
| Freeboard: | 2-6 feet |
| Volume at 2' of freeboard: | 20306 USG |
| Volume at 6' of freeboard: | 16922 USG |

Mixing Requirement:

Complete mix

Jet Mixing Equipment:

Jet mixing header:

| | |
|--------------------------------|------------------------------|
| Manufacturer: | Eco Equipment FEP Inc. |
| Model: | Eco Jet Mixing Header |
| Number of units/tank: | One (1) |
| Number of jets/header: | Four (4) |
| Type of jet: | Eco Bidirectional Jet Mixing |
| Jet Material: | High abrasion polyurethane |
| Jet Diameter (primary nozzle): | 2 1/8" Ø |
| Jet number: | JP-M1-212 |
| Jet orientation: | 0° |
| Flow per jet: | 325 USGPM |

Jet mixing header (cont'd):

Jet header diameter: 8" Ø
Header material: FRP (isophthalic resin) rated at 50 psi. Protected against ultraviolet race by "hot coat" solution UV inhibitor on exterior surfaces.

Supports:

Quantity: Two (2) supports for jet header
Material: 304 SS
Description: Dual vertical legs, 18" bottom wide and 16" top wide

Jet Motive Pump:

Number: One (1) dry pit pump mounted on base plate
Manufacturer: Fairbanks Morse
Model: 6" B5423-T30 Frame
Type: Dry pit installation
Flow: 1300 USGPM
Pressure: 20' TDH
Power: 460 V/3/60 Hz
HP motor: 10 HP, 1175 RPM, TEFC
Impellor: cast iron
Casing: cast iron
Discharge: 6" Ø
Accessories: - coupling
- coupling guard
- mechanical seal

Accessories:

- Two (2) DeZurick 8" Ø butterfly valves
- Two (2) Thorburn 6" Ø molded expansion joints
- Two (2) ½" Ø brass ball valves
- One (1) lot of steel pipe, ASTM A53, Grade B, Type E (ERW), including 8" x 6" straight reducers at discharge and suction
- One (1) 304 SS support for steel pipe

| ITEM | QTY | DESCRIPTION | MATL |
|------|-----|---|--------|
| 1 | 1 | FANPARKS MOTOR SET MOTIVE PUMP | |
| 2 | 1 | MCD 8" 80423-T30, 3/4" HP, 10 hp | |
| 3 | 2 | 8" P.V.C. RUBBER | |
| 4 | 2 | 1/2" BALL VALVE | BRASS |
| 5 | 2 | 8" BUTTERFLY VALVE | |
| 6 | 1 | PIPE SUPPORT | SS 304 |
| 7 | 1 | 8" #40 PIPE ASTM A53 GRADE B TYPE E (FRP) | |
| 8 | 1 | 8" #40 PIPE ASTM A53 GRADE B TYPE E (FRP) | |
| 9 | 2 | WATER HEADER SUPPORT | SS 304 |
| 10 | 1 | 8" WATER HEADER | FRP |
| 11 | 1 | 8" FULL WALL S.EEVE (BY OTHERS) | |
| 12 | 1 | 8" HALF WALL S.EEVE (BY OTHERS) | |
| 13 | 3 | 8" RUBBER GASKET 1/4" THK | NEOP |
| 14 | 4 | 6" RUBBER GASKET 1/4" THK | NEOP |

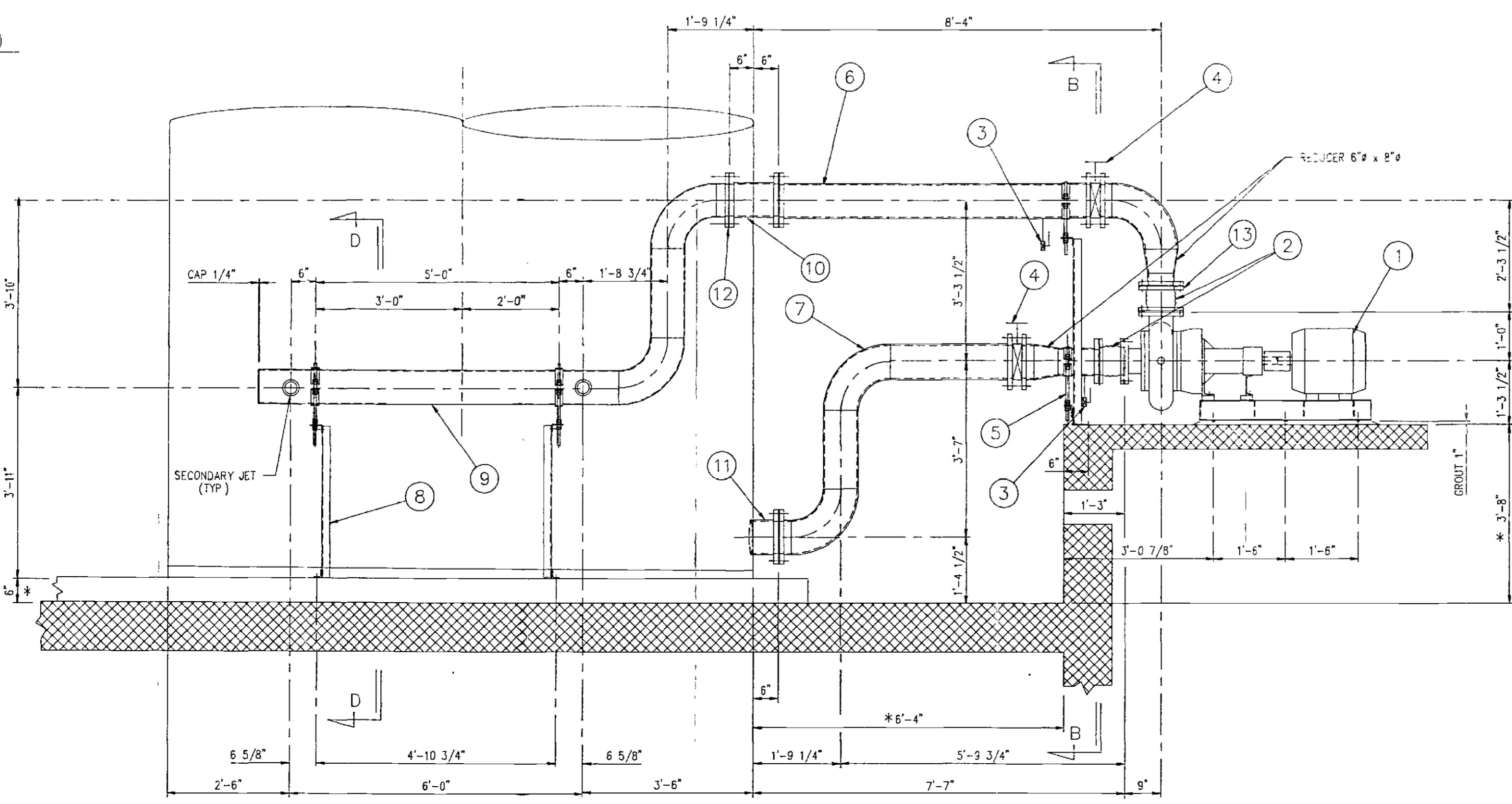
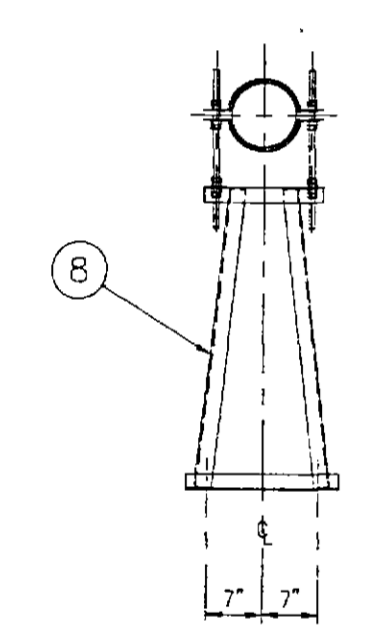
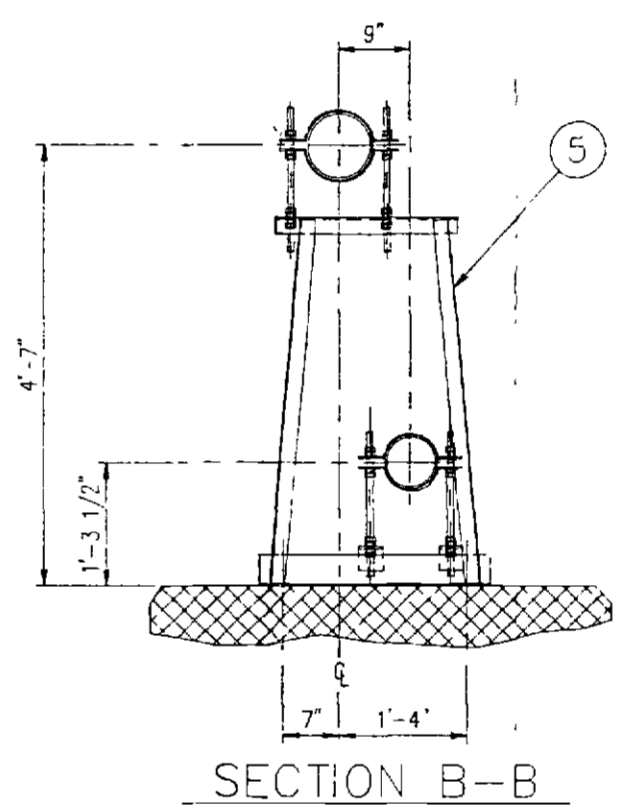
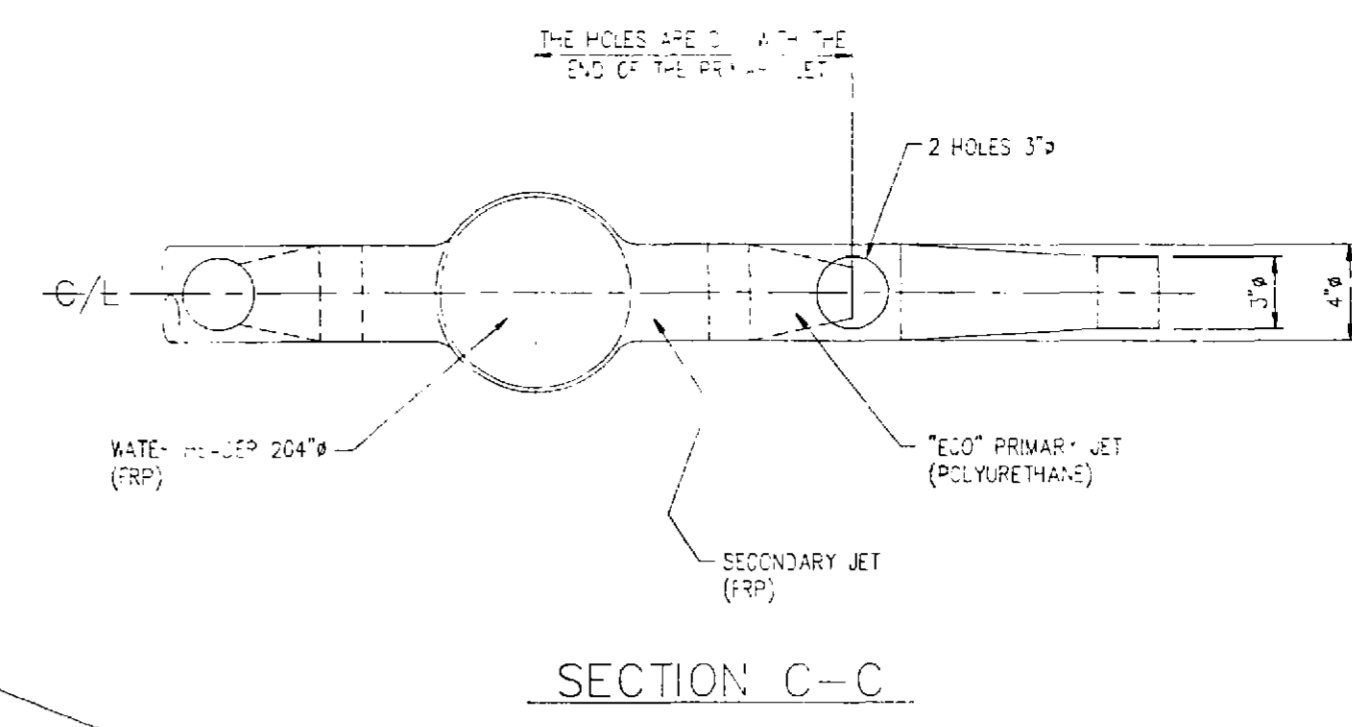
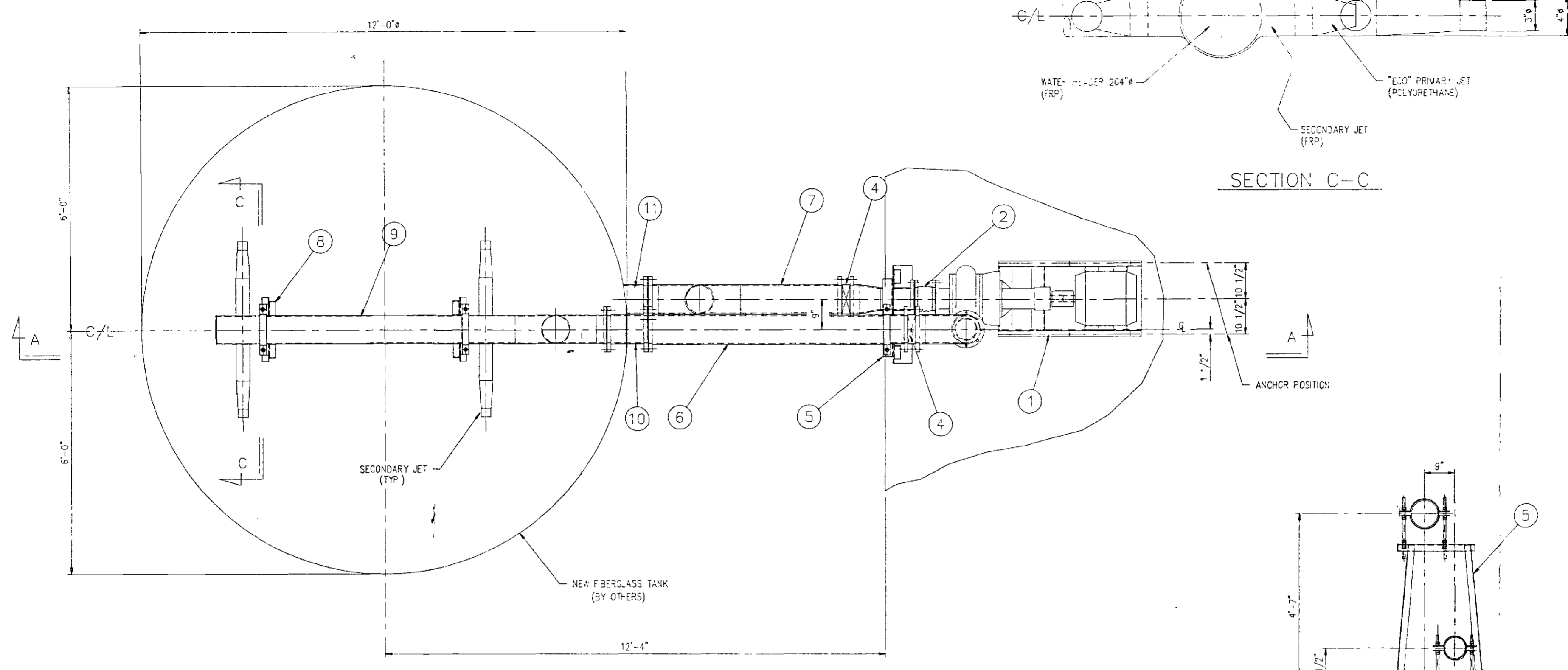

NOTE:
 -ANCHOR BOLTS 5/8" "WEJ-IT" BY OTHERS
 * -DIMENSIONS AS BEEN CONFIRMED BY "OHM REMEDIATION SERVICES CORP."

PAINT SPECIFICATION
PRIMER
 1 (ONE) COAT, INTERNATIONAL "INTERGARD EX", EPOXY-POLYAMIDE, CONFORM TO MIL-P-24441/1 30 MILS DRY MIN.
FINISH
 2 (TWO) COATS, INTERNATIONAL "INTERGARD 740", EPOXY-POLYAMIDE, CONFORM TO MIL-P-24441/3 3 MILS DRY MIN.

SUBMITTAL REVIEW
 REVIEWED FOR COMPLIANCE WITH CONTRACT DOCUMENTS. NO RESPONSIBILITY IS ASSUMED FOR CORRECTNESS OF DIMENSIONS OR DETAILS. THE CONTRACTOR/SUPPLIER SHALL ASSUME FULL RESPONSIBILITY FOR DEVELOPING AND CONTRACT REQUIREMENTS NOT SPECIFICALLY INDICATED ON THIS SUBMITTAL.
 NO EXCEPTIONS
 AMENDMENT REQUIRED
 MAKE CORRECTIONS NOTED
 REDESIGN-SEE REFERENCE
 5-10-95
 OHM REMEDIATION SERVICES CORP.
 NOTED FOR DESIGN

FOR APPROVAL

02349HH02X

| NO | DATE | REVISION | PAR |
|----|----------|------------------|-----|
| 1 | 95/04/11 | GENERAL REVISION | GL |

TITLE: MIXIJET GENERAL ARRANGEMENT

ECO EQUIPMENT FIN P.C.
 TEL: (514) 477-7878 FAX: (514) 477-7888 TERREBONNE, QUE.
 CLIENT: CAMP LEJEUNE

| | | |
|------------------------|--------------|-------------------|
| SCALE: N.T.S. | BY: GL | DATE: 95/03/28 |
| DESIGNED BY: | APPROVED BY: | PROJ. NO: 94-3453 |
| DRAWING NO: E-03453-1A | | SHEET 1 OF 1 |

APPENDIX H

SECTION 4

PUMP DATA

PUMP P - 121

Manufacturer: Electronic Metering Pumps

Model: VP H6MA-PTT4XXX

Manufacturer

Contact: Michael Wolfe

Phone

Number: (770) 998-1956

PUMP DATA

PUMP P - 211, 212

Manufacturer: Electronic Metering Pumps

Model: VP H6MA-KTC4XXX

Manufacturer

Contact: Michael Wolfe

Phone

Number: (770) 998-1956

12000, 13000, 14000 XV Series

ELECTRONIC METERING PUMPS

Installation Operation Maintenance Instruction

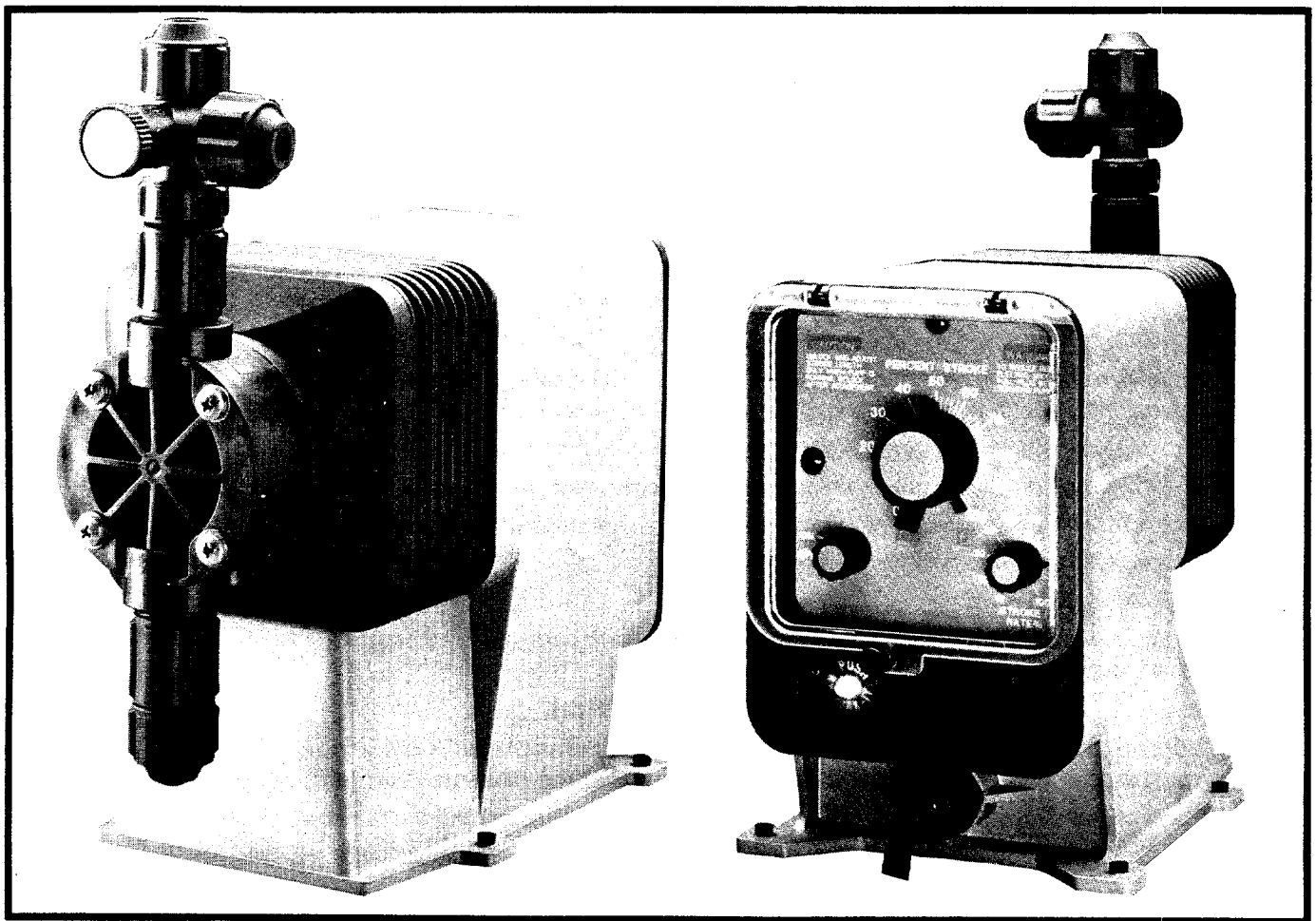

**READ ALL WARNINGS CAREFULLY
BEFORE INSTALLING**

TABLE OF CONTENTS

| | <u>Page</u> |
|---------------------------------------|-------------|
| SAFETY INSTRUCTIONS | 2 |
| INTRODUCTION | 3 |
| UNPACKING THE PUMP | 5 |
| PRECAUTIONS FOR OPERATION | 5 |
| INSTALLATION, PIPING AND WIRING | 7 |
| START-UP AND OPERATION | 11 |
| MAINTENANCE | 15 |
| TROUBLESHOOTING | 18 |
| EXPLODED VIEW DRAWINGS | 20 |
| REPAIR SERVICE | 23 |

SAFETY INSTRUCTIONS



When using chemical feed pumps, basic safety precautions should always be followed to reduce risk of fire, electric shock, and personal injury. Failure to follow these instructions could result in death or serious injury.



READ ALL INSTRUCTIONS

GENERAL SAFETY CONSIDERATIONS

- Always wear protective clothing including gloves and safety glasses when working on or near chemical metering pumps.
- Inspect tubing regularly when replenishing chemical solution for cracking or deterioration and replace as necessary. **(Always wear protective clothing and safety glasses when inspecting tubing.)**
- When pump is exposed to direct sunlight, use U.V. resistant tubing.
- Follow directions and warnings provided with the chemicals from the chemical manufacturer. User is responsible for determining chemical compatibility with chemical feed pump.
- Secure chemicals and metering pumps, making them inaccessible to children and pets.
- Make sure the voltage on the chemical metering pump matches the voltage at the installation.
- Do not cut plug off electrical cord or the ground lug - consult a licensed electrician for proper installation.
- Pump is **NOT** to be used to handle flammable liquids.

SAFETY OPERATING PROCEDURES

- All pumps are tested with water before shipment. Remove tubing and dry thoroughly if you are pumping chemical that will react with water (i.e. sulfuric acid).
- Finger tighten plastic connections. **DO NOT USE WRENCH.**
- Before repair or moving pump, disconnect power cord or turn off power to pump. De-pressurize system and drain chemical. **(Always wear protective clothing and safety glasses when working on metering pump.)**
- Always consult licensed plumber and electrician before installation and make sure to conform to local codes.
- Consult with local health officials and qualified water conditioning specialist when treating potable water.
- Be sure to de-pressurize system prior to hook-up or disconnection of metering pump.
- If point of injection is lower than chemical tank and pump, install an anti-siphon valve.
- **DO NOT MODIFY** pump as this poses a potentially dangerous situation and voids the warranty.
- For accurate volume output, pump must be **calibrated** under **all** operating conditions.

INTRODUCTION

These installation, operation and maintenance instructions cover your electronic metering pump. Refer to the pump nameplate to determine the actual model.

■ PRINCIPLE OF OPERATION

Diaphragm metering pumps are used to dispense chemicals or fluids. This is achieved by an electromagnetic drive mechanism (solenoid) which is connected to a diaphragm. When the solenoid is pulsed by the control circuit, it displaces the diaphragm which, through the use of check valves, moves the fluid out the discharge under pressure. When the solenoid is deenergized it returns the diaphragm and pulls more fluid into the pumphead and the cycle repeats.

The pump stroke rate is controlled by the internal circuit and is changed by turning the rate knob. The mechanical stroke length of the pump is controlled by the stroke length knob.

■ MATERIALS OF CONSTRUCTION

The wetted materials (those parts that contact the solution being pumped) available for construction are polypropylene, PVC, SAN, Hypalon, Viton, Teflon, 316 Stainless Steel, PVDF, Ceramic and Alloy C. These materials are very resistant to most chemicals. However, there are some chemicals, such as strong acids or organic solvents, which cause deterioration of some elastomer and plastic parts, such as diaphragm, valve seat, or head. Consult Chemical Resistance Guide or Supplier for information on chemical compatibility.

Various manufacturers of plastics, elastomers and pumping equipment publish guidelines that aid in the selection of wetted materials for pumping commercially available chemicals and chemical compounds. Two factors must always be considered when using an elastomer or plastic part to pump chemicals. They are:

1. **The temperature of service:** Higher temperatures increase the effect of chemicals on wetted materials. The increase varies with the material and the chemical being used. A material quite stable at room temperature might be affected at higher temperatures.
2. **Material choice:** Materials with similar properties may differ greatly from one another in performance when exposed to certain chemicals.

■ MANUFACTURER'S PRODUCT WARRANTY

The manufacturer warrants its equipment of its manufacture to be free of defects in material or workmanship. Liability under this policy extends for eighteen (18) months from the date of purchase or one (1) year from date of installation or whichever comes first. The manufacturer's liability is limited to repair or replacement of any device or part which is returned, prepaid, to the factory and which is proven defective upon examination. This warranty does not include installation or repair cost and in no event shall the manufacturer's liability exceed its selling price of such part.

The manufacturer disclaims all liability for damage to its products through improper installation, maintenance, use or attempts to operate such products beyond their functional capacity, intentionally or otherwise, or any unauthorized repair. Replaceable elastomeric parts are expendable and are not covered by any warranty either expressed or implied. The manufacturer is not responsible for consequential or other damages, injuries or expense incurred through use of its products.

The above warranty is in lieu of any other warranty, either expressed or implied. The manufacturer makes no warranty of fitness or merchantability. No agent of ours is authorized to make any warranty other than the above.

Pumps carrying the NSF seal are listed for swimming pools, spas, and hot tubs, and when proper materials are selected, are capable of handling but not limited to the following chemical solutions:

| | | | |
|------|------------------------|-----|-------------------|
| 12½% | sodium hypochlorite | 12% | aluminum sulphate |
| 2% | calcium hypochlorite | 10% | hydrochloric acid |
| 20% | dichloro-s-triazinone | 10% | sodium hydroxide |
| 5% | trichloro-s-triazinone | 5% | sodium carbonate |



■ UNPACKING THE PUMP

Check all equipment for completeness against the order and for any evidence of shipping damage. Shortages or damages should be reported immediately to the carrier and to the seller of the equipment.

The carton should contain: (See Figure A)

- Metering Pump
- Clear Flexible Suction Tubing
- Stiff White Discharge Tubing
- Footvalve/Strainer Assy.
- Anti-siphon/backpressure Injection Valve Assy.
- One Instruction Book that you are now reading
- Bleed Valve Assembly (most models)
- Tube Wand Assembly (most models)



Figure A

Make sure that all items have been removed from the shipping carton before it is discarded.

PRECAUTIONS FOR OPERATION

Each Electronic Metering Pump has been tested to meet prescribed specifications and safety standards. Proper care in handling, installation and operation will help in ensuring a trouble free installation.

Please read all these cautionary notes prior to installation and start-up of your metering pump.

1. **Important: Pump must be installed and used with supplied back pressure/injection valve supply. Failure to do so could result in excessive pump output flow.**
2. Handle the pump with care. Dropping or heavy impact causes not only external damage to the pump, but also to electrical parts inside.
3. Install the pump in a place where the ambient temperature does not exceed 40°C (104°F). The pump is water resistant and dust proof by construction and can be used outdoors, however **do not operate the pump submerged**. To avoid high internal pump temperatures, do not operate in direct sunlight.
4. Install the pump in a place convenient for its future maintenance and inspection, then fix it to prevent vibration.
5. Protective caps must be removed prior to installing tubing onto valve assemblies. Use tubing of specified size. Connect the tubing to the suction side securely to prevent the entrance of outside air. Make sure that there is no liquid leakage on the discharge side.

6. Be careful to check that the voltage of the installation matches the voltage indicated on the pump nameplate. Each pump is equipped with a three prong plug. Always be sure the pump is grounded. To disconnect, do not pull wire but grip the plug with fingers and pull out. Do not use the receptacle in common with heavy electrical equipment which generates surge voltage. It can cause the failure of the electronic circuit inside the pump.
7. Tampering with electrical devices can be potentially hazardous. Always place chemicals and pump installation well out of the reach of children.
8. Never repair or move the metering pump while operating. Always disconnect electrical power. **For safety, always wear protective clothing (protective gloves and safety glasses) when working on or near chemical metering pumps.**
9. An air bleed valve is available for most models. Air purges should be performed when the pump chamber contains no fluid at the time of start-up. As a safety measure, connect the return tubing to the air bleed valve and bypass fluid back to storage tank or a suitable drain.
10. Chemicals used may be dangerous and should be used carefully and according to warnings on the label. Follow the directions given with each type of chemical. Do not assume chemicals are the same because they look alike. Always store chemicals in a safe location away from children and others. We cannot be responsible for the misuse of chemicals being fed by the pump. Always have the material safety data sheet (MSDS) available for any fluid being pumped.
11. All pumps are pretested with water before shipment. Remove head and dry thoroughly if you are pumping a material that will react with water, (i.e. sulfuric acid, polymers). Valve seats, ball checks, gaskets, and diaphragm should also be dried. Before placing pump into service, extreme care should be taken to follow this procedure.
12. Valve cartridges are stamped to indicate fluid flow direction. Always install so that markings read from top to bottom.
13. When metering hazardous material DO NOT use plastic tubing, strictly use proper rigid pipe. Consult supplier for special adapters or valve assemblies.
14. **Pump is NOT to be used to handle or meter flammable liquids or materials.**
15. Standard white discharge tubing is not recommended for installations exposed to direct sunlight. Consult supplier for special black tubing.
16. Factory will not be held responsible for improper installation of pump, or plumbing. All cautions are to be read thoroughly prior to hook-up and plumbing. For all installations a professional plumber should be consulted. Always adhere to local plumbing codes and requirements.
17. When using pump with pressurized systems, make sure the pressure of the system does not exceed the maximum pressure rating on the pump nameplate. Be sure to de-pressurize system prior to hook up or disconnecting the metering pump.
18. Electronic power modules are equipped with automatic reset thermal overload devices and may reset unexpectedly.
19. The pump is designed to operate using a backpressure/injection valve. If the discharge point is below the liquid level of the source or if the discharge pressure is less than the suction pressure, siphoning may occur. To correct this condition, install an anti-siphon valve or other anti-siphon device. Check local regulations which may apply. (Reg. Figure G1).

INSTALLATION, PIPING AND WIRING

The metering pump should be located in an area that allows convenient connections to both the chemical storage tank and the point of injection. The pump is water resistant and dust proof by construction and can be used outdoors, however **do not operate submerged**. Avoid continuous temperatures in excess of 40°C (104°F). To do otherwise could result in damage to the pump.

MOUNTING

Typical mounting arrangements are shown in Figures B to E.

Important: Injection point must be higher than the top of the solution supply tank to prohibit gravity feeding, unless a suitable backpressure is always present at the injection point.

1. For wall or shelf mounting, refer to Figure E. Connect suction tubing to suction valve of chemical pump. Suction valve is the lower valve. Tubing should be long enough so that the footvalve/strainer assembly hangs about 2-3 inches above the bottom of chemical tank. To keep chemical from being contaminated, the tank should have a cover.
2. Flooded suction mounting (installing the pump at the base of the chemical storage tank, Figure C) is the most trouble free type of installation and is recommended for very low output requirements. Since the suction tubing is filled with chemical, priming is accomplished quickly and the chance of losing prime is reduced.

To mount pump, drill 4 holes of 1/4" diameter in the shelf as shown in the dimension drawing (Figure F). Attach pump securely using four #10 bolts and nuts.

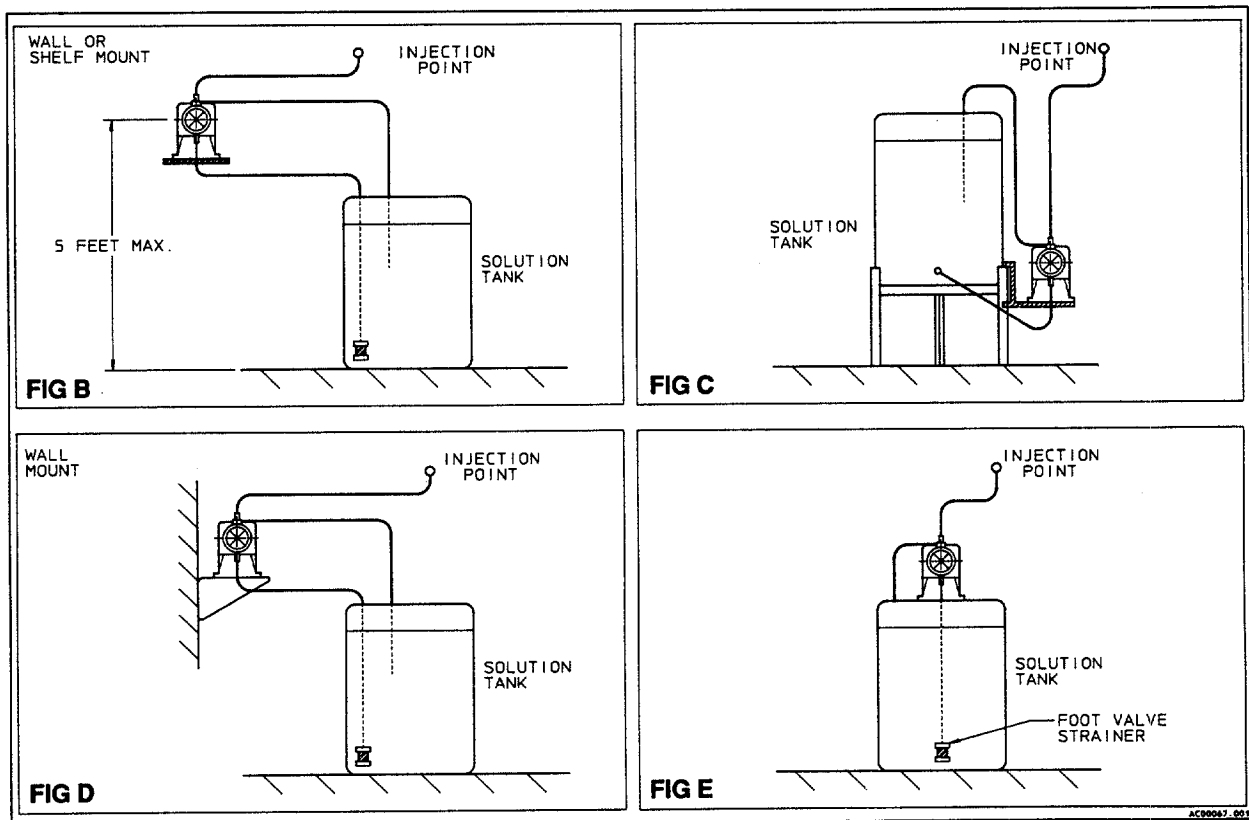

3. The pump can be mounted to a wall as shown in Figure D. A wall mount bracket kit is available which includes all necessary hardware to mount the pump to the wall. Mounting the pump other than as shown in Figure D defeats the purpose of the housing drain. Mounting dimensions for the pump are provided in Figure F for reference.

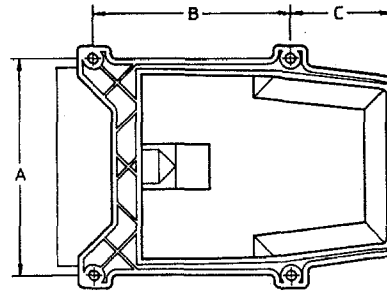

| HOUSING SIZE | DIMENSIONS | | |
|--------------|------------|------|------|
| | A | B | C |
| 12000 XV | 4.81 | 4.38 | 2.19 |
| 13000 XV | 4.81 | 4.38 | 2.19 |
| 14000 XV | 5.56 | 4.38 | 2.19 |

NOTE: VPH4, VPH5 ARE SIZED SAME AS 14000 XV.

Figure F

4. The pump can be mounted on top of a solution tank as shown in Figure E. Install chemical pump on the cover. Insert suction tubing through the center hole and cut tubing so foot valve/strainer hangs about 2 or 3 inches above the bottom of the tank. Mount the chemical pump rigidly by drilling four 1/4" holes and using our #10 screws and nuts.

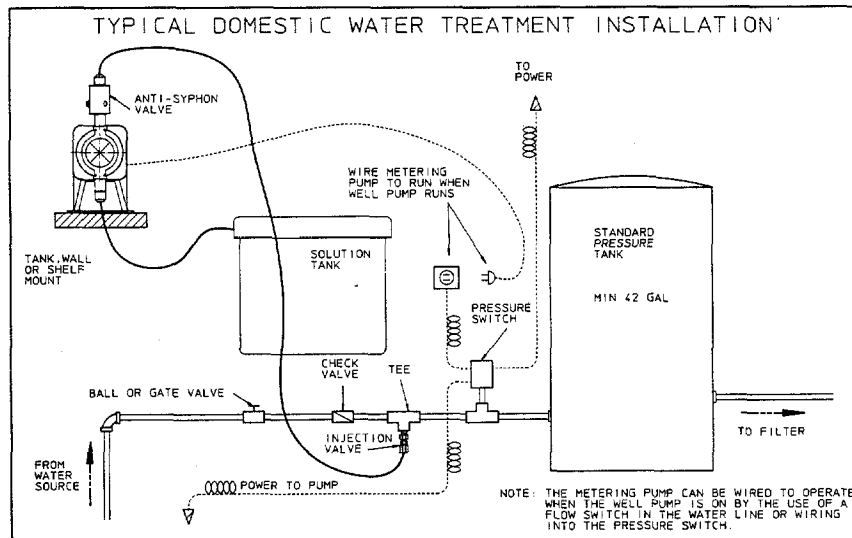

FIG G1

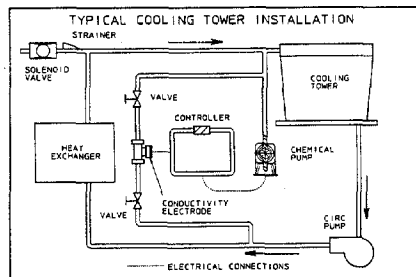

FIG G2

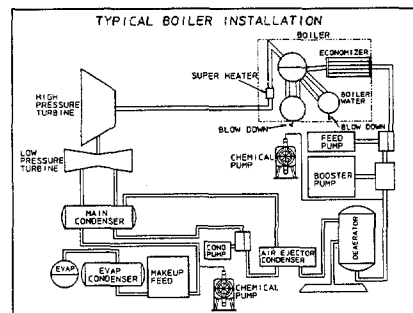

FIG G3

PIPING

1. Use provided tubing of specified size for connection. Connect tubing securely to prevent leakage of chemical and the entrance of air. Since plastic nuts are used for fittings, they should not be tightened excessively i.e. hand tighten only.
2. If the air bleed valve assembly is being used, a return line (tubing) should be securely connected and routed back to the storage tank. **To avoid possible injury from chemicals do not attempt to prime using a bleed valve without installing a return line.**
3. When pump is shelf mounted or top mounted on tank, suction tubing should kept as short as possible.
4. To maintain metering performance, a backpressure/injection valve is provided. The injection valve must be installed in the discharge line. Best practice is to install the injection valve at the point of chemical injection.
5. If the discharge tubing is going to be exposed to direct sunlight, black tubing should be used instead of the standard white translucent tubing supplied with each pump. To obtain, contact supplier.
6. To prevent clogging or check valve malfunction always install a strainer assembly to the end of the suction tubing (Figure E). This footvalve/strainer assembly should always be installed 2 to 3 inches above the bottom of the chemical tank. This will help prevent clogging the strainer with any solids that may settle on the tank bottom. The chemical tank and footvalve/strainer should be cleaned regularly, to ensure continuous troublefree operation. If the chemical being pumped regularly precipitates out of solution or does not dissolve easily or completely (e.g. calcium hydroxide), a mixer should be used in the chemical tank. These are readily available in many motor configurations and mountings. To obtain, contact supplier.
7. A flooded suction (tank liquid level always at a higher elevation than the pump) is recommended when pumping sodium hypochlorite (NaOCl) and hydrazine solution (N_2H_2) etc. which are liable to produce air bubbles. Maintaining a low liquid temperature will also help eliminate this problem.
8. Pipe corrosion can result if dilution at the injection point does not occur rapidly. This problem is easily prevented by observing this simple rule: install injection fitting so that the end is in the center of the flow stream of the line being treated. Trim injector tip as required. See Figure H. Note: Extended injection assemblies are available for large water lines. Consult your supplier for more information.

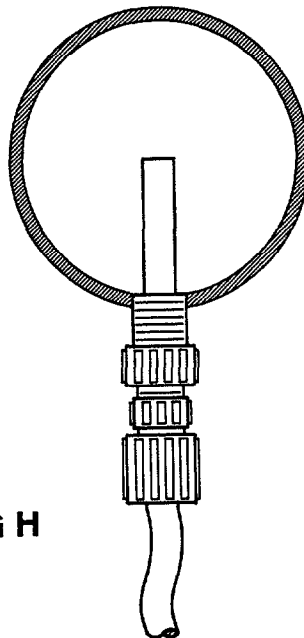
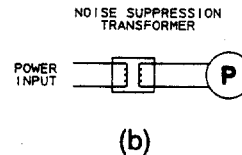
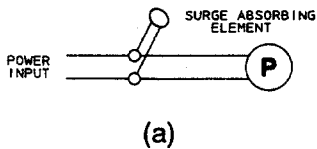

FIG H

WIRING

1. The metering pump should be wired to an electrical source which conforms to those on the pump nameplate. (Applying higher voltage than the pump is rated for will damage the internal circuit.)
2. **⚠ WARNING** -- Risk of electrical shock. This pump is supplied with a three prong grounding type power plug. To reduce risk of electric shock, connect only to a properly grounded, grounding type receptacle.
3. In the electronic circuit of the control unit, measures for surge voltage are made by means of surge absorbing elements and high voltage semiconductors. Nevertheless, excessive surge voltage may cause failure in some areas. Therefore, the receptacle should not be used in common with heavy electrical equipment which generates high voltage. If this is unavoidable, however, measures should be taken by (a) the installation of a surge absorbing element (varister of min. surge resistance 2000A) to the power supply connection of the pump, or (b) the installation of a noise suppression transformer.



4. Signal input to the external pulse signal input terminals ([EXT],[STOP]) **must be a no-voltage signal** from relay-contacts, etc. and the input of other signals is prohibited. (in the case of relay contacts, 100 ohms or below at ON and 1M ohms or above at OFF.) The pulse duration of the input signal must be 10 milliseconds or over and the frequency of the input signal must not exceed 125 times/min. Signal cord is provided with the pump.

WELL PUMP SYSTEM INSTALLATION

1. Ensure that the metering pump voltage matches the voltage of the well pump. Typical well pump electrical circuits are shown in Figure I. All electric wiring should be installed in accordance to local electrical codes by a licensed electrician.
2. Install the backpressure/injection valve on the discharge side of the metering pump into a tee which is installed into the water line going to the pressure tank. Typical installations are found in figures G1, G2 and G3.

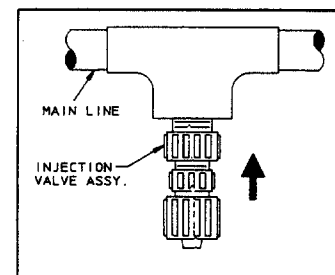

FIG J

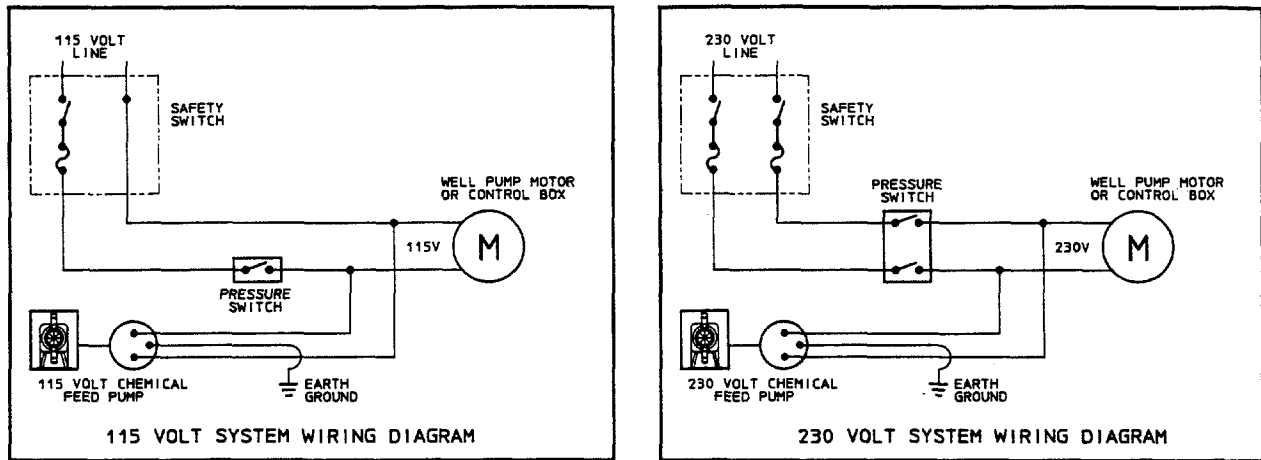

FIG 1

START UP AND OPERATION

POWER

All metering pumps are available in 115 volts at 50/60 Hertz, single phase. Optionally 230 volts at 50/60 Hertz, single phase can be provided. **Prior to start-up always check to insure that the pump voltage/frequency/phase matches that of the power supply.**

PRIMING

CAUTION: When working on or around a chemical metering pump installation, protective clothing and gloves and safety glasses should be worn at all times.

All pumps are tested with water. If the chemical to be pumped reacts when mixed with water (e.g. sulfuric acid) the pump head should be removed and dried thoroughly along with the diaphragm and valve seats.

1. Turn on the power to the pump. The green LED will light up and flash off each time the pump strokes.
2. Adjust the stroke rate knob to the 100% setting mark (for more information see "Capacity Control").
3. Adjust the stroke length knob to the 100% setting mark (for more information see "Capacity Control").
4. If the discharge line is connected directly to a pressurized system it should be temporarily bypassed during priming of the pump. A bleed valve will simplify this operation by allowing easy bypass of the discharge fluid. All air must be purged from the pumphead before the pump will pump against pressure.

- A) While pump is running, turn adjustment screw counterclockwise.
- B) Run with valve open until a solid stream of fluid comes out of the bypass tubing (1/4 x 3/8 supplied with valve), no air bubbles.
- C) Close air bleed valve by turning adjustment screw clockwise.

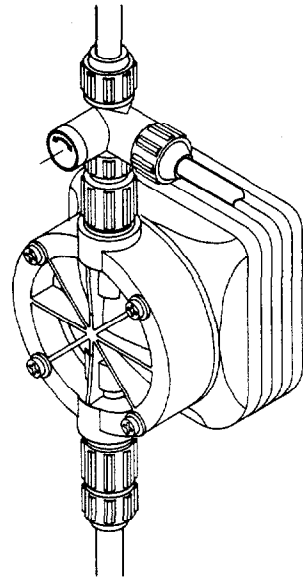

- 5. Chemical should reach the pumphead after a few minutes of operation. If not, remove the discharge fitting and moisten the discharge valve area (ball check and valve seats) with a few drops of chemical being fed to the metering pump. **For safety, always use protective clothing and gloves, wear safety glasses and use a proper container to hold the chemical.**
- 6. If the pump continues to refuse to prime, refer to Troubleshooting Section of these instructions.
- 7. Once the pump has been primed and is pumping the chemical through the head, turn off the power, reconnect the discharge tubing (if it had been removed) and immediately clean any spilled chemical that is on the pump housing or head.
- 8. Turn the power on once more and adjust the pump flow to the desired rate (see "Capacity Control").
- 9. Always check the calibration of the pump after start-up. It's best to calibrate the pump under your typical use conditions.

CAPACITY CONTROL

Capacity can be controlled by means of the stroke length adjusting knob or stroke frequency adjusting knob. Graphs are for illustration purposes only, use a calibration column for accurate calibration. Contact you pump supplier for proper calibration equipment.

(1) Stroke Frequency Adjustment:

- Stroke frequency can be controlled from 10 to 100% (12 to 125 spm) by means of the electronic circuit.
- Stroke frequency can be set by means of the stroke frequency adjusting knob even while the pump is in operation.

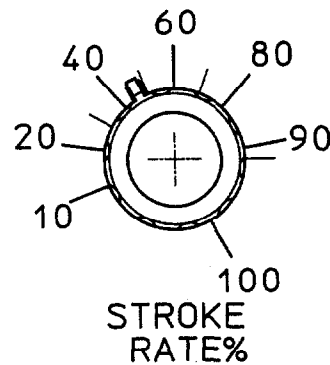

(2) **Stroke Length Adjustment:**

- Stroke length can be controlled within 0 to 100% of the diaphragm displacement. (It should be controlled within 10 to 100% for practical use.)
- Stroke length can be set by means of the stroke length adjusting knob while the pump is in operation. **Do not turn the knob while the pump is stopped.**

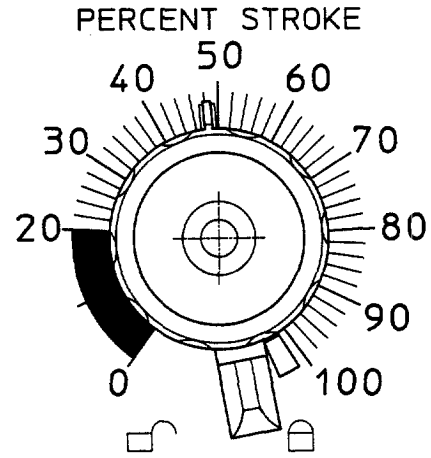

(3) **Controlling Procedure:**

Proper set points for stroke length and stroke frequency should be determined after consideration of the pump and characteristics of the fluid. The following procedure is recommended from the viewpoint of pump performance. **Note: The closer the stroke length is to 100%, the better the pump performance will be.**

- A) Set the stroke length to 100% then adjust the stroke frequency for coarse capacity control.
- B) Measure the capacity.
- C) When the measured capacity is less than the required value, increase the stroke frequency and measure the capacity again.
- D) Then, adjust the stroke length for fine capacity control.
- E) Finally, measure the capacity and make sure that the required value is obtained.

| | | | |
|----------------|-------------------------------------|---|---|
| Example | Selected Model | = | VPD4 |
| | Set Stroke Length | = | 100% |
| | Set Stroke Rate | = | 100% |
| | Output Capacity (Rated Pressure) | = | 21 GPD* |
| | Desired Flow | = | 15 GPD |
| | Adjust Stroke Rate to 80% | = | |
| | Output Capacity | = | $0.80 \times 21 = 16.8 \text{ GPD}^*$ |
| | Stroke Length Setting | = | $\frac{15}{16.8} \times 100 = 90\% \text{ approximate}$ |

Thus to obtain the desired flow, stroke length is set at 90% and stroke rate is set at 80% i.e. output capacity = $0.90 \times 0.80 \times 21 = 15 \text{ GPD}^*$

* Check these values by measurement. Output capacity is higher when feeding against less than rated pressure.

OPERATION BY EXTERNAL INPUT SIGNALS:

The pump can be controlled by three types of input signals. All are fully isolated from AC input power and from Earth ground. The input socket connections are located at the bottom of the control panel face and the signal cords are provided with the pump. Remove rubber plugs to access plug sockets.

STOP FUNCTION:

Operation of the pump can be stopped by an external signal input. When the external signal is input to the terminal marked [STOP] which is provided at the bottom of the control panel, the lamp 'STOP' (red) lights up and operation of the pump is stopped. The stop function overrides both manual settings and external input signals at other terminals.

CAUTION : Operation of more than one pump from the same contact closure will damage the pump circuits. When such operation is required, the pump circuits must be electrically isolated from one another by means of a multicontact control relay or similar means.

- Input signals should be no-voltage signals from relay contacts, etc. and the input of other signals is prohibited. (In case of relay contacts, electric resistance must be 100 ohms or below at ON and 1M ohm or above at OFF).

The stop function is commonly used in conjunction with a tank float switch. The float switch contacts are normally open but when the tank level falls past a certain point the contacts close and the pump stops.

EXTERNAL PACING FUNCTION:

The pump's stroke rate can be controlled by an external input signal. When the input signal line is connected and the EXTERNAL/OFF/MANUAL switch is in the external position and a contact signal is input to the terminal marked [EXTERNAL] the pump makes one discharge stroke.

CAUTION : Operation of more than one pump from the same contact closure will damage the pump circuits. When such operation is required, the pump circuits must be electrically isolated from one another by means of a multicontact control relay or similar means.

- When the 'ON' signal pulse is input, the pump operates one stroke and the fluid is discharged. In addition, the pump can be operated continuously at a rate of 0 to 125 strokes/min. by repeated input of 'ON' and 'OFF' signals.
- After receiving an input signal, the pump generates the necessary power pulse to actuate the solenoid. The external signal input is debounced by the pump circuit. The pump will not stroke in response to a spurious or erratic input signal that follows at a rate greater than 125 spm. If the external signal rate exceeds 125 spm, the pump will stroke at half the external signal rate to prevent overdosing and to protect the pump from overheating.
- Input signals should be no-voltage signals from relay contacts, etc. and the input of other signals is prohibited. (In the case of relay contacts, electric resistance must be 100 ohms or below at ON and 1M ohms or above at OFF).
- Cycle rate of the input signal should not exceed 125 times/min.
- Typical wiring is shown at right for use with switch closure flowmeters.

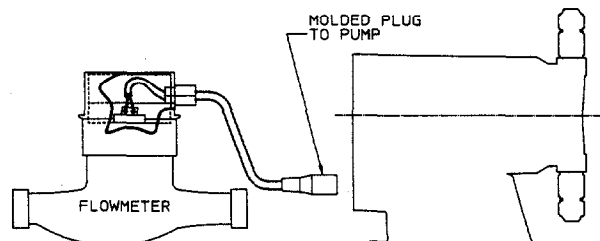

4-20 mA DC INPUT FUNCTION:

The pump's stroke rate can also be controlled by a 4-20 mA DC signal applied to the terminal marked [4-20 mA].

- For the 4-20 input to have any effect on the pump output rate, the AUTO/OFF/MANUAL switch must be in the AUTO position.
- The 4-20 mA input signal affects the pump's output as per the graph below:
NOTE: Inverse acting control signal capability must be requested, standard control signal is direct acting.

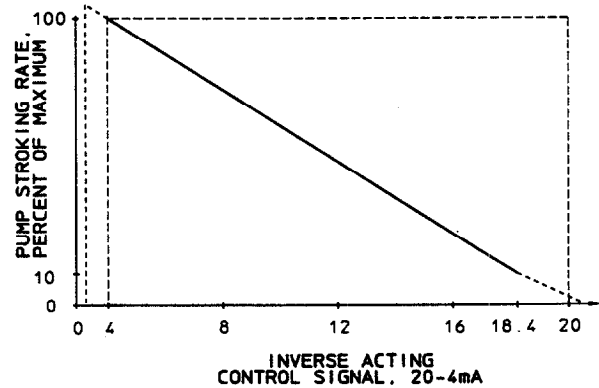
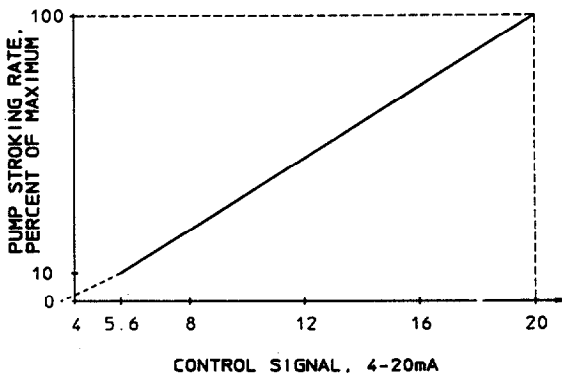

- The signal cord polarity is:
Black = Common
White = Positive
Wrong polarity can result in excess flow.
- Signal input impedance is 124 ohms.
- Remove cap from pump socket labeled 4-20mA, use polarized cord supply with pump to connect control circuit to pump. Plug cord into pump socket labeled 4-20mA.

MAINTENANCE

CAUTION : Before performing any maintenance or repairs on chemical metering pumps, be sure to disconnect all electrical connections and insure that all pressure valves are shut off and pressure in the pump and lines has been bled off.

Always wear protective clothing, gloves and safety glasses when performing any maintenance or repairs on chemical metering pumps.

ROUTINE MAINTENANCE

1. Routinely check the physical operating condition of the pump. Look for the presence of any abnormal noise, excessive vibration, low flow and pressure output or high temperatures [when running constantly at maximum stroke rate, the pump housing temperature can be up to 160°F (70°C)]
2. For optimum performance, cartridge valves should be changed every 4-6 months. Depending on the application, more frequent changes may be required. Actual operating experience is the best guide in this

situation. Repeated short-term deterioration of valve seats and balls usually indicates a need to review the suitability of wetted materials selected for the application. Contact the supplier for guidance.

3. Check for leaks around fittings or as a result of deteriorating tubing e.g. when standard white translucent discharge tubing is exposed to direct sunlight. Take appropriate action to correct leak by tightening fittings or replacing components.
4. Keep the pump free of dirt/debris as this provides insulation and can lead to excessive pump temperatures.
5. If the pump has been out of service for a month or longer, clean the pump head/valve assemblies by pumping fresh water for approximately 30 minutes. If the pump does not operate normally after this "purging run", replace cartridge valve assemblies.

DISASSEMBLY AND ASSEMBLY DIAPHRAGM REMOVAL

1. Flush pumphead and valve assemblies out by running pump on water or other suitable neutralizing solution. Wash outside of pump down if chemical has dripped on pump.
2. Set stroke length of pump to 0% and unplug pump.
3. Disconnect tubing or piping from the pump. Remove the four pumphead screws and then remove the pumphead assembly.
4. Remove the diaphragm by grasping it at the outer edges and turning it counterclockwise until it unscrews from the electronic power module (EPM). Don't lose the deflection plate or diaphragm shims which are behind the diaphragm. Note shim quantity can be from 0 to 3.
5. Inspect diaphragm if it is intended to be used again. Look for indications of the Teflon face being overstretched, (localized white areas) or the elastomer on the back of the diaphragm being worn. Excessive amounts of either condition require diaphragm replacement.

DIAPHRAGM REPLACEMENT

Refer to drawings in the back of the manual.

1. When replacing the diaphragm, it's always a good idea to replace the valve cartridges and other worn parts. A kit is available from your supplier with all parts necessary to completely rebuild your pump's wet end. All your supplier needs to know is the "KOPkit No." on your pump's nameplate to supply this kit.
2. Set pump stroke length to 0% and unplug the pump .
3. If you kept the shims from the original diaphragm or know the original quantity you can avoid Step #4 for shimming the diaphragm and go to Step #5.
4. Slide the diaphragm deflection plate onto the back of the diaphragm stud, radius side towards the diaphragm. Next slide three shims onto the diaphragm threaded stud and screw the diaphragm into the EPM unit. Refer to sketch. Turn diaphragm clockwise until deflection plate and shims are screwed down tight against the solenoid shaft, and the diaphragm stops turning. If there is a gap between the adaptor and diaphragm, repeat the procedure removing one shim each time until the diaphragm just touches the adaptor or is slightly recessed.

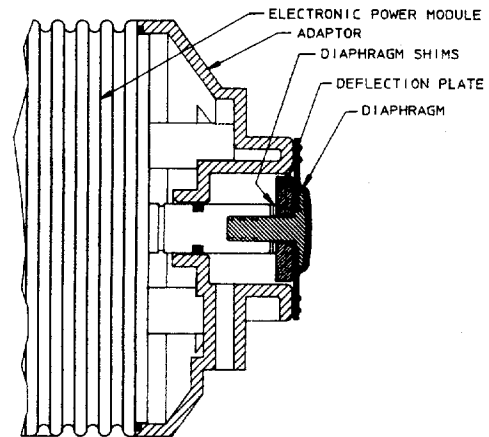

5. Apply grease to areas of the diaphragm that contact the deflection plate or radius on the adaptor.
6. Screw the diaphragm into the EPM unit's shaft with the deflection plate and appropriate number of shims in between.
7. Adjust stroke length to 50%. It is easier to do this if you temporarily turn the pump on. Place the pumphead onto the adaptor with valve flow arrows pointing up and install and tighten pumphead screws. Tighten screws until pumphead pulls up against adaptor.
8. Adjust stroke length back to 100% for easier priming and place pump back into service.

VALVE REPLACEMENT

1. Flush pump to clean any chemical from pumphead.
2. Unplug pump and disconnect any tubing or piping.
3. Unscrew valve cartridges and discard. Also remove O-Rings down inside pumphead.
4. Using new O-Rings, install new valve cartridges with stamped letters reading from top to bottom. Hand tighten only, do not use wrenches or pliers. This is especially important when the pumphead is SAN material.
5. Reconnect tubing or piping and reinstall the pump.

TROUBLESHOOTING

| PROBLEM | PROBABLE CAUSE | REMEDY |
|----------------------------------|---|---|
| LOSS OF CHEMICAL RESIDUAL | <ol style="list-style-type: none"> 1. Pump setting too low 2. Scale at injection point 3. Solution container allowed to run dry | <ol style="list-style-type: none"> 1. Adjust to higher setting (pump must be operating during the stroke length adjustment). 2. Clean injection parts with 8% muriatic acid or undiluted vinegar. Also, see Maintenance Section). 3. Refill the tank with solution and prime. (See Start-Up and Operation Section). |
| TOO MUCH CHEMICAL | <ol style="list-style-type: none"> 1. Pump setting too high 2. Chemical in solution tank too rich 3. Siphoning of chemical into well or main line | <ol style="list-style-type: none"> 1. Lower pump setting (pump must be operating to adjust stroke length knob). 2. Dilute chemical solution. NOTE: For chemical that reacts with water, it may be necessary to purchase a more dilute grade of chemical direct from chemical supplier. 3. Test for suction or vacuum at the injection point. If suction exists, install an anti-siphon valve. |
| LEAKAGE AT TUBING | <ol style="list-style-type: none"> 1. Worn tube ends 2. Chemical attack | <ol style="list-style-type: none"> 1. Cut off end of tubing (about 1") and then replace as before. 2. Consult your seller for alternate material. |
| FAILURE TO PUMP | <ol style="list-style-type: none"> 1. Leak in suction side of pump 2. Valve seats not sealing 3. Low setting on pump 4. Low solution level 5. Diaphragm ruptured 6. Pumphead cracked or broken 7. Pumphead contains air or chlorine gas 8. Breakdown or disconnection of wiring 9. Voltage drop 10. Malfunction of electronic control board | <ol style="list-style-type: none"> 1. Examine suction tubing. If worn at the end, cut approximately an inch off and replace. 2. Clean valve seats if dirty or replace with alternate material if deterioration is noted. 3. When pumping against pressure, the dials should be set above 20% capacity for a reliable feed rate. 4. Solution must be above foot valve. 5. Replace diaphragm as shown in the "Maintenance Section." Check for pressure above rated maximum at the injection point. NOTE: Chemical incompatibility with diaphragm material can cause diaphragm rupture and leakage around the pump head. 6. Replace pump head as shown in "Maintenance Section." Make sure fittings are hand tight only. Using pliers and wrench can crack pump head. Also, chemical incompatibility can cause cracking and subsequent leakage. 7. Bleed pump head, see "Air Bleed Operation." 8. Connect wiring properly. Check fuse or circuit breaker. 9. Take measures after investigation of cause. 10. Contact supplier. |

| PROBLEM | PROBABLE CAUSE | REMEDY |
|--------------------------|--|--|
| PUMP LOSES PRIME | <ol style="list-style-type: none"> 1. Dirty check valve 2. Ball checks not seating or not sealing properly 3. Solution container allowed to run dry | <ol style="list-style-type: none"> 1. Remove and replace or clean off any scale or sediment. 2. Check seat and ball checks for chips, clean gently. If deformity or deterioration is noted, replace part with proper material. Resulting crystals can hold check valves open, therefore the valves must be disassembled and cleaned. Be sure to replace all parts as shown in the Parts Diagram (at the end of the manual). 3. Refill the tank with solution and prime. (See Start-Up and Operation Section). |
| FITTING | <ol style="list-style-type: none"> 1. Loose fittings 2. Broken or twisted gasket 3. Chemical attack | <ol style="list-style-type: none"> 1. Lower pump setting (pump must be operating to adjust stroke length knob). 2. Check gaskets and replace if broken or damaged. 3. Consult your pump supplier for alternate material. |
| LEAKAGE AT TUBING | <ol style="list-style-type: none"> 1. Worn tube ends 2. Chemical attack | <ol style="list-style-type: none"> 1. Cut off end of tubing (about 1") and then replace as before. 2. Consult your seller for alternate material. |
| FAILURE | <ol style="list-style-type: none"> 1. Too much pressure at discharge 2. Check valves not sealing 3. Output dials not set at maximum 4. Suction lift height too much 5. Pump equipped with spring loaded high viscosity valves | <ol style="list-style-type: none"> 1. Turn off all pressure valves, loosen outlet tubing connection at discharge point. Remove discharge valve cartridge. Dampen ball check and valve sets with a few drops of solution. Set pump dials to maximum rate. When pump is primed, reconnect all tubing connections. 2. Disassemble, loosen, clean and check for deterioration swelling. Reassemble and wet the valve assembly, then prime. See Start-Up and Operating Section. 3. Always prime pump with output dials set at maximum rated capacity. 4. Decrease suction lift or pull vacuum on pump discharge until pump is primed. 5. Loosen discharge valve to aid in priming, take necessary safety precautions. Or apply vacuum to pump discharge. |

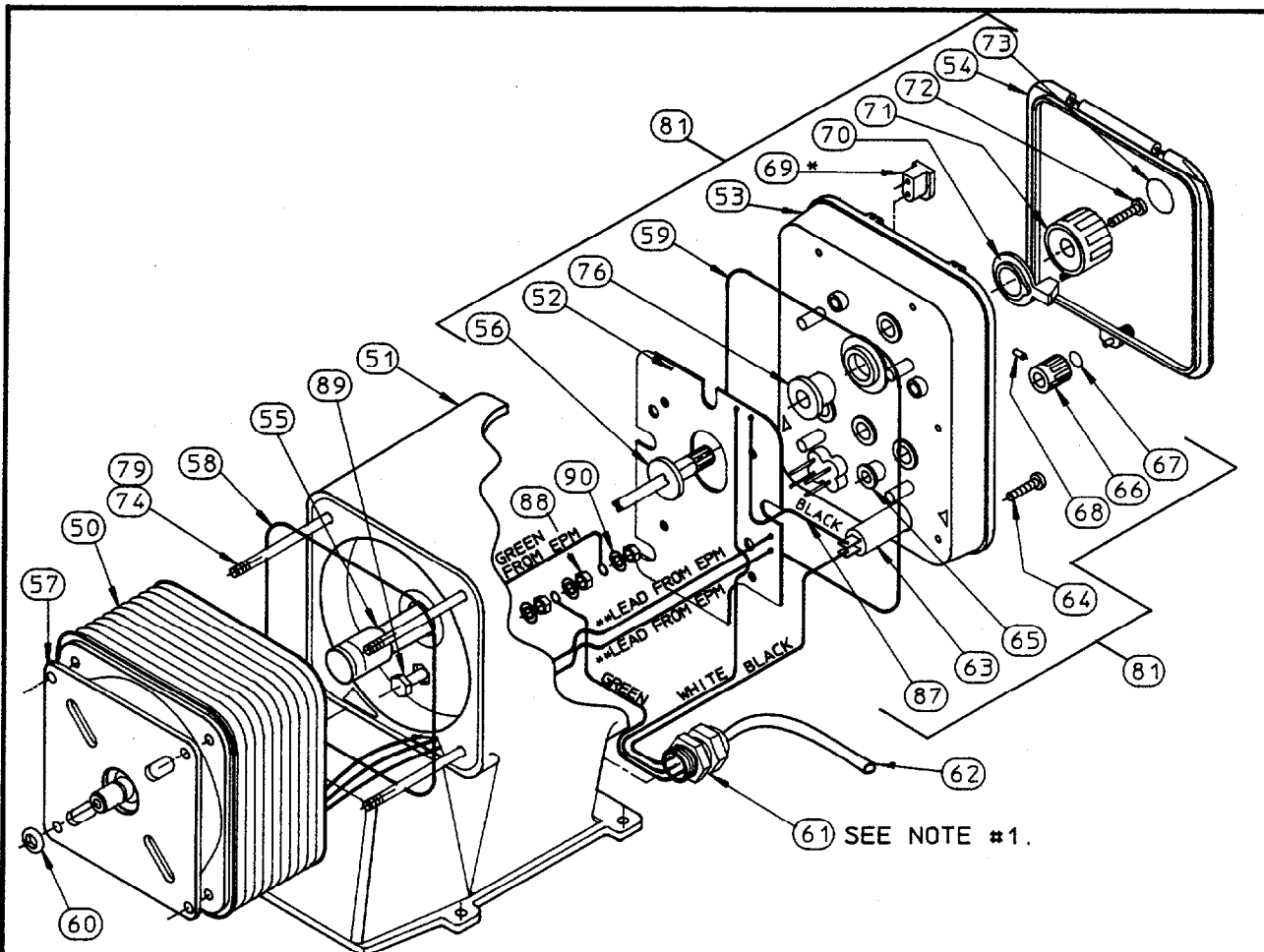

| ITEM | DESCRIPTION | QTY | ITEM | DESCRIPTION | QTY |
|------|-----------------------------|-----|------|-----------------------------|-----|
| 50 | ELECTRONIC POWER MODULE EPM | 1 | 68 | KNOB SET SCREW | 2 |
| 51 | HOUSING | 1 | *69 | PIN PLUG | 2 |
| 52 | ELECTRONIC CONTROL BOARD | 1 | 70 | LOCKING TAB | 1 |
| 53 | CONTROL PANEL | 1 | 71 | KNOB, STROKE LENGTH | 1 |
| 54 | DUST COVER ASSEMBLY | 1 | 72 | KNOB MOUNTING SCREW | 1 |
| 55 | FEMALE ADJUSTMENT SHAFT | 1 | 73 | KNOB STICKER, STROKE LG. | 1 |
| 56 | MALE ADJUSTMENT SHAFT | 1 | 74 | EPM MOUNTING SCREW | 4 |
| 57 | EPM RETAINING PLATE | 1 | 76 | GROMMET, STROKE LENGTH | 1 |
| 58 | EPM/HOUSING O-RING | 1 | 77 | PANEL LABEL (NOT SHOWN) | 1 |
| 59 | CONTROL PANEL O-RING | 1 | 79 | EPM MOUNTING WASHER | 4 |
| 60 | SECONDARY SEAL | 1 | 81 | CONTROL PANEL ASSEMBLY | 1 |
| 61 | STRAIN RELIEF | 1 | *84 | STOP/FCTN LABEL (NOT SHOWN) | 1 |
| 62 | POWER CORD | 1 | *85 | STOP/FCTN CORDS (NOT SHOWN) | 2 |
| 63 | CIRCUIT BREAKER | 1 | 87 | JUMPER WIRE | 1 |
| 64 | CONTROL PANEL SCREW | 5-6 | 88 | GROUND LUG NUT | 3 |
| 65 | GROMMET, STROKE RATE/SWITCH | 2 | 89 | GROUND LUG BOLT | 1 |
| 66 | KNOB, STROKE RATE/SWITCH | 2 | 90 | GROUND LUG WASHER | 3 |
| 67 | KNOB STICKER, RATE/SWITCH | 2 | 92 | BREAKER COVER (NOT SHOWN) | 1 |

NOTES:

1. TERMINAL LOCATIONS ON THE CIRCUIT BOARD VARY DEPENDING ON THE CONTROL OPTION.
2. LATER PUMP VERSIONS ARE SUPPLIED WITH AN INTEGRAL STRIAN RELIEF/CORD ASSEMBLY.
3. ** - 115 VOLT EPM UNITS HAVE GREY LEADS.
** - 230 VOLT EPM UNITS HAVE RED LEADS.

* - THESE ITEMS USED ON EXTERNAL PACING, STOP & 4-20ma/STOP OPTIONS.

| | |
|------------------------------|-------------|
| ALL DIMENSIONS ARE IN INCHES | |
| DWG. TITLE | |
| DRIVE ASSEMBLY | |
| OWN BY: PTP | CAD DWG. # |
| DATE: 1-23-90 | AC00013.001 |

| REF | REVISION | DATE |
|-----|----------|------|
|-----|----------|------|

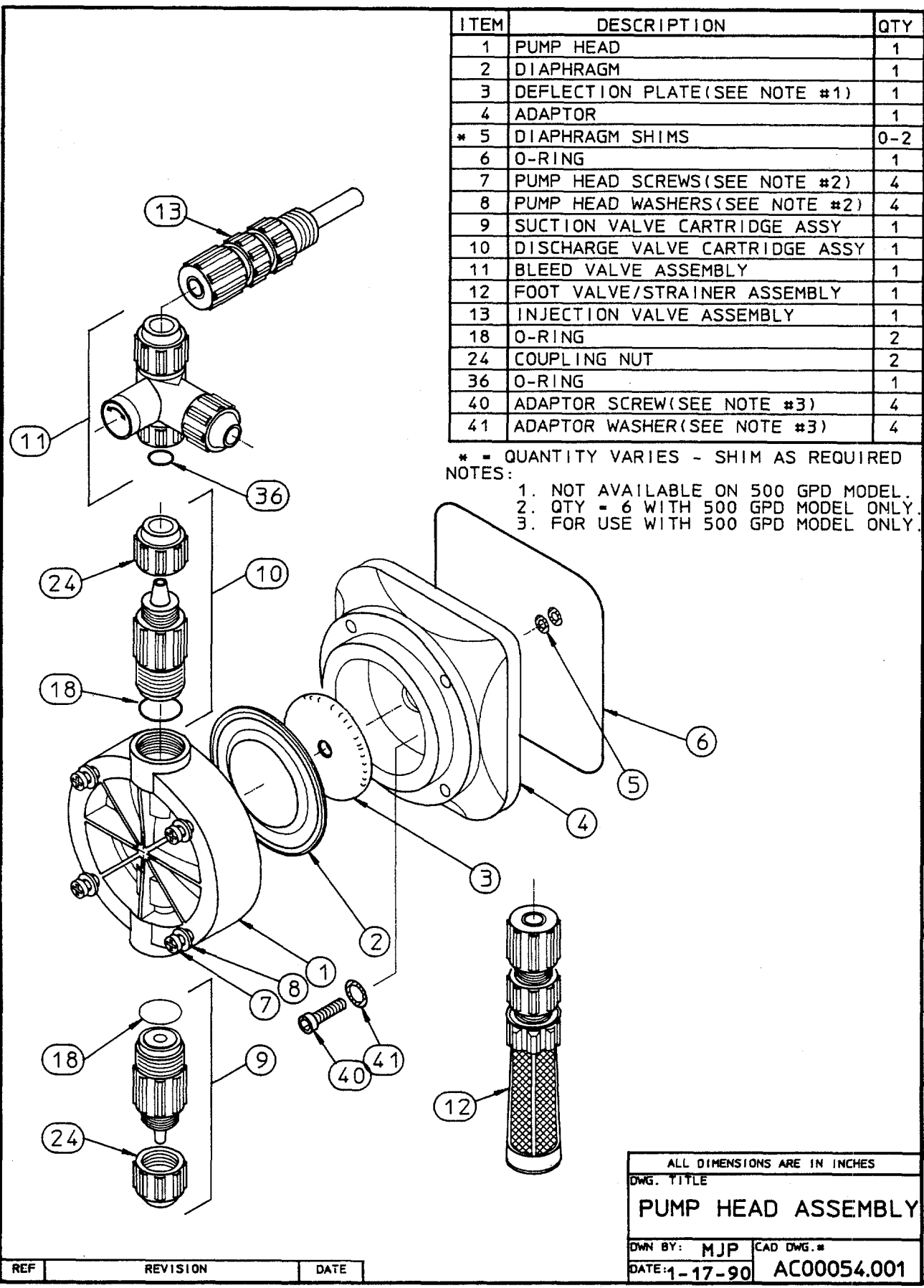

| ITEM | DESCRIPTION | QTY |
|------|---------------------------------|-----|
| 1 | PUMP HEAD | 1 |
| 2 | DIAPHRAGM | 1 |
| 3 | DEFLECTION PLATE (SEE NOTE #1) | 1 |
| 4 | ADAPTOR | 1 |
| * 5 | DIAPHRAGM SHIMS | 0-2 |
| 6 | O-RING | 1 |
| 7 | PUMP HEAD SCREWS (SEE NOTE #2) | 4 |
| 8 | PUMP HEAD WASHERS (SEE NOTE #2) | 4 |
| 9 | SUCTION VALVE CARTRIDGE ASSY | 1 |
| 10 | DISCHARGE VALVE CARTRIDGE ASSY | 1 |
| 11 | BLEED VALVE ASSEMBLY | 1 |
| 12 | FOOT VALVE/STRAINER ASSEMBLY | 1 |
| 13 | INJECTION VALVE ASSEMBLY | 1 |
| 18 | O-RING | 2 |
| 24 | COUPLING NUT | 2 |
| 36 | O-RING | 1 |
| 40 | ADAPTOR SCREW (SEE NOTE #3) | 4 |
| 41 | ADAPTOR WASHER (SEE NOTE #3) | 4 |

* - QUANTITY VARIES - SHIM AS REQUIRED
 NOTES:
 1. NOT AVAILABLE ON 500 GPD MODEL.
 2. QTY = 6 WITH 500 GPD MODEL ONLY.
 3. FOR USE WITH 500 GPD MODEL ONLY.

| | |
|------------------------------|-------------|
| ALL DIMENSIONS ARE IN INCHES | |
| DWG. TITLE | |
| PUMP HEAD ASSEMBLY | |
| DWN BY: MJP | CAD DWG.# |
| DATE: 1-17-90 | AC00054.001 |

| REF | REVISION | DATE |
|-----|----------|------|
| | | |

REPAIR SERVICE

Normally following the instructions in the previous sections of the manual will rectify any pump problems. If, however, after following these instructions the pump does not perform properly, it can be returned for repair. Please follow the instructions below:

1. Pump cannot be serviced properly if the original pump nameplate or data contained on the nameplate is not intact.
2. Thoroughly flush pumphead and outside of pump with water or a suitable fluid to neutralize any residual chemical left in pump.
3. Include written explanation of the following:
 - A) Problem _____
 - B) Pumped Fluid _____
Name _____
Viscosity _____
Fluid Temperature _____
 - C) Pressure @ Discharge _____
@ Suction _____
or Suction Lift _____
 - D) Environmental Temperature _____
 - E) Electrical Service _____
Volts _____
Hz _____
Phase _____
 - F) Nameplate Data _____
Series _____
Serial # _____
KOPkit # _____
4. Package the pump in the original box if available and send to the address specified by your pump supplier.

KOPkits™

Keep-On-Pumping kits that can save you time and money!

The manufacturer has built a reputation for superior reliability by supplying carefully-designed, high-quality equipment. Even the best equipment, however, requires a minimal amount of maintenance. KOPkits are designed to guard against unnecessary downtime and assure you the highest level of efficient and uninterrupted service.

KOPkits contain those recommended spare parts which will most likely require normal maintenance.

A typical KOPkit includes Valve Cartridges with O-Rings, Head, Diaphragm, Secondary O-Ring Seal, Head Screws, Washers and an exploded view drawing.

KOPkits will save you money. When you need a part, you've got it! You can cut downtime and production loss from days to minutes. You also save by buying parts in KOPkit form compared with buying individual parts.

Each KOPkit part is vacuum-sealed to keep it clean even when stored for long periods of time.

A KOPkit is a troubleshooter's best friend. In the event of a breakdown, it will put you back in business fast! Preventive maintenance will insure continuous high performance of your pump.

Keep on pumping! Get all the money-saving and security benefits of KOPkits immediately.



Typical KOPkit

Selecting a KOPkit

The KOPkit part number is displayed by a "K" on the pump model label as shown. The KOPkit number is the pump model number-prefixed.

| | | | |
|--|-----|---------------------------|-------|
| SERIES | | SERIAL # | |
| [] | | [] | |
| MAXIMUM OUTPUT | | GPD LPD | |
| MAXIMUM PRESSURE | | PSI Kg/CM ² | |
| VOLTS | Hz | AMPS | PHASE |
| [] | [] | [] | 1 |
| WARNING: TO REDUCE THE RISK OF ELECTRIC SHOCK, CONNECT ONLY TO A PROPERLY GROUNDED GROUNDING-TYPE RECEPTACLE | | | |
| KOPKIT# | | K [] | |



PRECISION II **XV Series**

PARTS IDENTIFICATION SCHEDULE

- Wetted Component Assemblies
- Drive Assemblies
- Control Panel Assemblies

12000, 13000 AND 14000 XV SERIES WETTED COMPONENT ASSEMBLIES PARTS IDENTIFICATION

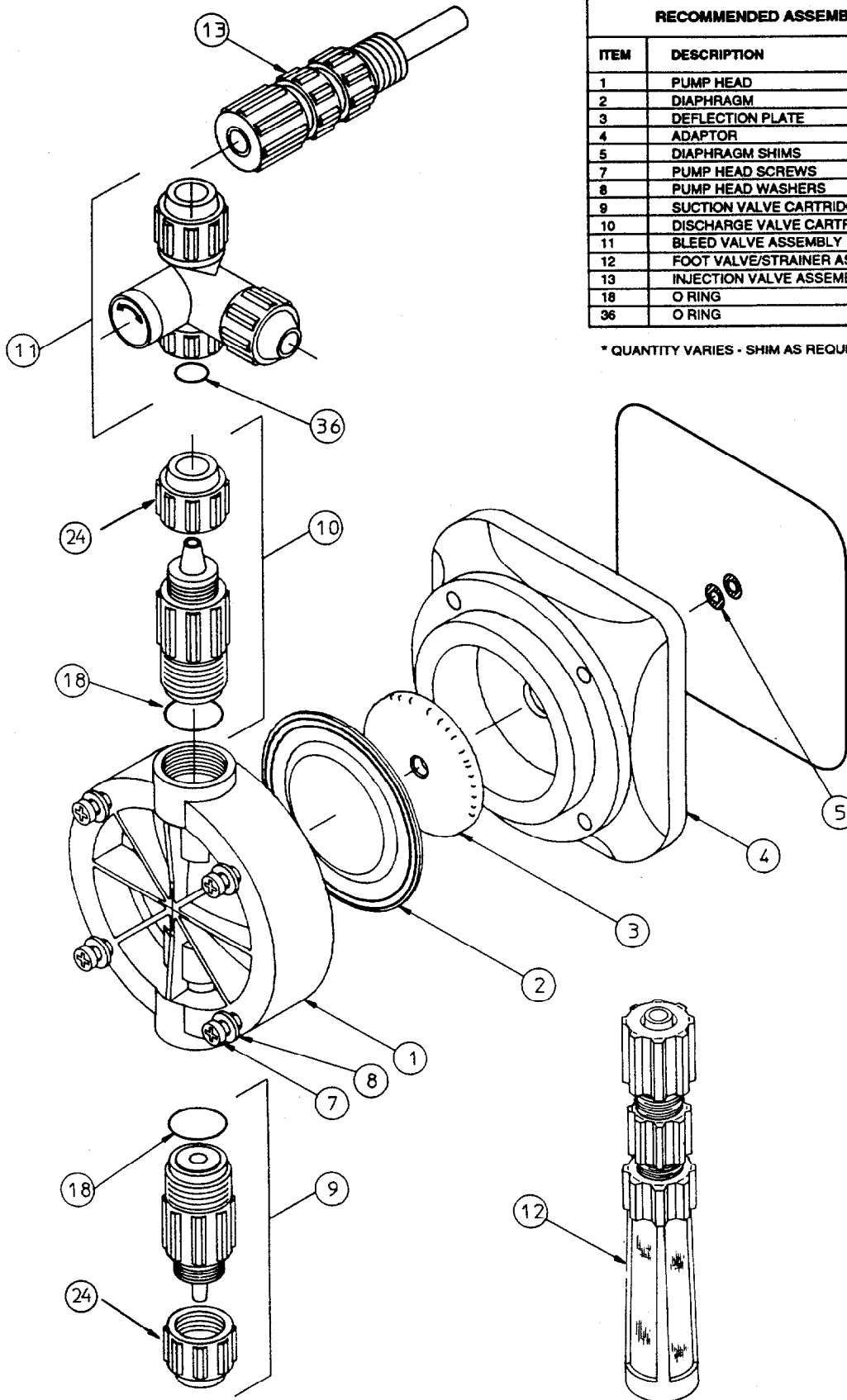

| RECOMMENDED ASSEMBLIES AND PARTS | | |
|----------------------------------|------------------------------------|------|
| ITEM | DESCRIPTION | QTY |
| 1 | PUMP HEAD | 1 |
| 2 | DIAPHRAGM | 1 |
| 3 | DEFLECTION PLATE | 1 |
| 4 | ADAPTOR | 1 |
| 5 | DIAPHRAGM SHIMS | *0-2 |
| 7 | PUMP HEAD SCREWS | 4 |
| 8 | PUMP HEAD WASHERS | 4 |
| 9 | SUCTION VALVE CARTRIDGE ASSEMBLY | 1 |
| 10 | DISCHARGE VALVE CARTRIDGE ASSEMBLY | 1 |
| 11 | BLEED VALVE ASSEMBLY | 1 |
| 12 | FOOT VALVE/STRAINER ASSEMBLY | 1 |
| 13 | INJECTION VALVE ASSEMBLY | 1 |
| 18 | O RING | 2 |
| 36 | O RING | 1* |

* QUANTITY VARIES - SHIM AS REQUIRED

12000, 13000 AND 14000 XV SERIES DRIVE ASSEMBLY AND CONTROL PANEL PARTS IDENTIFICATION

NOTE:

1. TERMINAL LOCATIONS ON THE CIRCUIT BOARD VARY DEPENDING ON THE CONTROL OPTION.

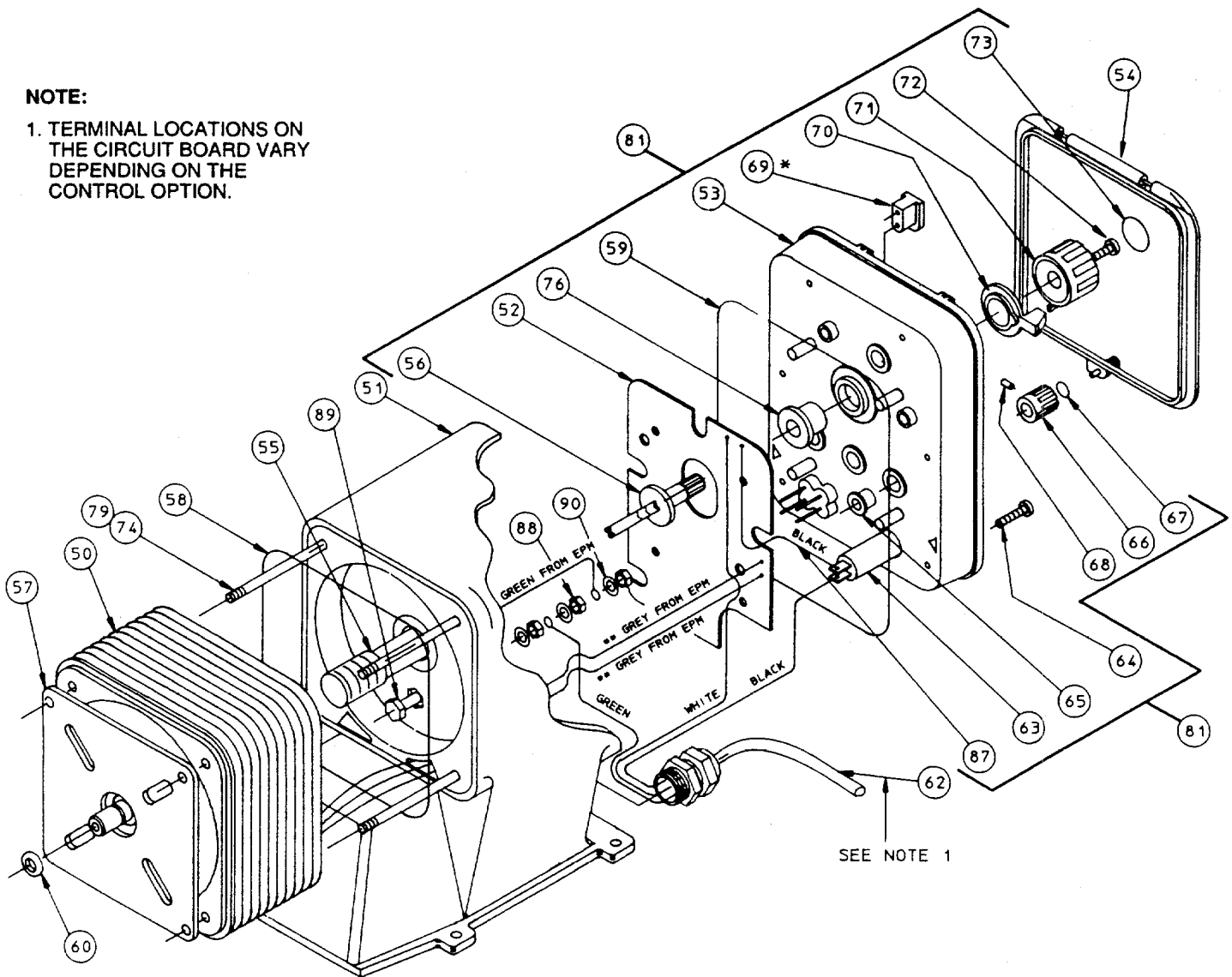

| REPLACEMENT ASSEMBLIES AND PARTS | | |
|----------------------------------|-----------------------------|-----|
| ITEM | DESCRIPTION | QTY |
| 50 | EPM | 1 |
| 51 | HOUSING | 1 |
| 52 | ELECTRONIC CONTROL BOARD | 1 |
| 53 | CONTROL PANEL | 1 |
| 54 | DUST COVER ASSEMBLY | 1 |
| 55 | FEMALE ADJUSTMENT SHAFT | 1 |
| 56 | MALE ADJUSTMENT SHAFT | 1 |
| 57 | EPM RETAINING PLATE | 1 |
| 58 | EPM/HOUSING O-RING | 1 |
| 59 | CONTROL PANEL O-RING | 1 |
| 60 | SECONDARY SEAL | 1 |
| 62 | POWER CORD | 1 |
| 63 | CIRCUIT BREAKER | 1 |
| 64 | CONTROL PANEL SCREW | 5-6 |
| 65 | GROMMET, STROKE RATE/SWITCH | 1 |

| REPLACEMENT ASSEMBLIES AND PARTS | | |
|----------------------------------|----------------------------|-----|
| ITEM | DESCRIPTION | QTY |
| 66 | KNOB, STROKE RATE/SWITCH | 1 |
| 67 | KNOB STICKER RATE SWITCH | 2 |
| 68 | KNOB SET SCREW | 2 |
| 69 | PIN PLUG | 2 |
| 70 | LOCKING TAB | 1 |
| 71 | KNOB, STROKE LENGTH | 1 |
| 72 | KNOB MOUNTING SCREW | 1 |
| 73 | KNOB STICKER STROKE LENGTH | 1 |
| 74 | EPM MOUNTING SCREW | 4 |
| 76 | GROMMET STROKE LENGTH | 1 |
| 81 | CONTROL PANEL ASSEMBLY | 1 |
| 88 | GROUND LUG NUT | 3 |
| 89 | GROUND LUG BOLT | 1 |
| 90 | GROUND LUG WASHER | 3 |
| 92 | BREAKER COVER (NOT SHOWN) | 1 |

NOTE:

* THESE ITEMS USED ON EXTERNAL PACING/STOP AND 4-20 MA/STOP OPTIONS.

** 115 BOLT EPM UNITS HAVE GREY LEADS. 230 VOLT EPM UNITS HAVE RED LEADS.

12000, 13000 AND 14000 XV SERIES WETTED COMPONENT ASSEMBLIES PARTS IDENTIFICATION

- Digits 3, 4 are provided in charts for proper model identification.
- Complete model information is published in price schedule PCP-PSLX 0193.

| PART NO. | QUANTITY | MODEL VP (DIGITS 3, 4) |
|---|----------|------------------------|
| ITEM NO. 1: PUMP HEAD (GFPPL) | | |
| L0200200-FPP | 1 | A2, B2 |
| L0200300-FPP | 1 | A3, B3, D3 |
| L0200400-FPP | 1 | B4, D4, E4, F4, G4, H4 |
| L0200500-FPP | 1 | G5, H5 |
| L0200600-FPP | 1 | H6 |
| L0200700-FPP | 1 | H7, K7 |
| L0200800-PPL | 1 | H8 |
| ITEM NO. 1: PUMP HEAD (PVC) | | |
| L0200300-PVC | 1 | A3 |
| L0200400-PVC | 1 | B4, E4 |
| L0200500-HPV | 1 | G5 |
| L0200600-HPV | 1 | H6 |
| L0200700-HPV | 1 | H7, K7 |
| L0200800-HPV | 1 | H8 |
| ITEM NO. 1: PUMP HEAD (SAN) | | |
| L0200300-SAN | 1 | A3 |
| L0200400-SAN | 1 | B4, E4 |
| L0200500-SAN | 1 | G5 |
| L0200600-HSN | 1 | H6 |
| L0200700-HSN | 1 | H7, K7 |
| ITEM NO. 1: PUMP HEAD (S.S. 316) | | |
| L0200200-316 | 1 | A2, B2 |
| L0200300-316 | 1 | A3, B3, D3 |
| L0200400-316 | 1 | B4, D4, E4, F4, G4, H4 |
| L0200500-316 | 1 | G5, H5 |
| L0200600-316 | 1 | H6 |
| L0200700-316 | 1 | H7, K7 |
| ITEM NO. 1: PUMP HEAD (PVDF) | | |
| L0200200-PVD | 1 | A2, B2 |
| L0200300-PVD | 1 | A3, B3, D3 |
| L0200400-PVD | 1 | B4, D4, E4, F4, G4, H4 |
| L0200500-PVD | 1 | G5, H5 |
| L0200600-PVD | 1 | H6 |
| L0200700-PVD | 1 | H7, K7 |
| ITEM NO. 2: DIAPHRAGM | | |
| L0300900-THY | 1 | A2, B2 |
| L0301000-THY | 1 | A3, B3, D3 |
| L0301100-THY | 1 | B4, D4, E4, F4, G4, H4 |
| L0301200-THY | 1 | G5, H5 |
| L0301300-THY | 1 | H6 |
| L0301400-THY | 1 | H7, K7 |
| L0301600-THY | 1 | H8 |
| ITEM NO. 3: DEFLECTION PLATE | | |
| L2100200-FPP | 1 | A2, B2 |
| L2100300-FPP | 1 | A3, B3, D3 |
| L2100400-FPP | 1 | B4, D4, E4, F4, G4, H4 |
| L2100500-FPP | 1 | G5, H5 |
| L2100600-FPP | 1 | H6 |
| L2100700-FPP | 1 | H7, K7 |

12000, 13000 AND 14000 XV SERIES WETTED COMPONENT ASSEMBLIES (CONT.) PARTS IDENTIFICATION

| PART NO. | QUANTITY | MODEL VP (DIGITS 3, 4) |
|---|----------|--|
| ITEM NO. 4: ADAPTOR | | |
| L0400200-FPP | 1 | A2, B2 |
| L0400300-FPP | 1 | A3, B3, D3 |
| L0400400-FPP | 1 | B4, D4, E4, F4, G4, H4 |
| L0400500-FPP | 1 | G5 |
| L0400600-FPP | 1 | H4 |
| L0400700-FPP | 1 | H5 |
| L0400800-FPP | 1 | H6 |
| L0400900-FPP | 1 | H7, K7 |
| L0401400-ALU | 1 | H8 |
| ITEM NO. 5: DIAPHRAGM SHIMS | | |
| L9901200-BRS | 0-2 | ALL MODELS |
| ITEM NO. 7: PUMP HEAD SCREWS | | |
| L9801700-188 | 4 | A2, A3, B2, B3, B4, D3, D4, E4, F4, G4, H4 |
| L9801800-188 | 4 | G5, H5, H6, H7, K7 |
| L9803400-188 | 6 | H8 |
| L9803300-188 (S.S. HEAD ONLY) | 4 | A3, B3, D3, B4, D4, E4, F4, G4, H4 |
| L9803400-188 (S.S. HEAD ONLY) | 4 | G5, H5, H6, H7, K7 |
| ITEM NO. 8: PUMP HEAD WASHERS | | |
| L9801300-188 | 4 | A2, A3, B2, B3, B4, D3, D4, E4, F4, G4, H4 |
| L9801400-188 | 4 | G5, H5, H6, H7, K7 |
| L9801400-188 | 6 | H8 |
| ITEM NO. 9: SUCTION VALVE ASSEMBLY | | |
| Refer to price schedule for selection | 1 | TUBING SIZES AND MATERIALS ARE LISTED |
| ITEM NO. 10: DISCHARGE VALVE ASSEMBLY | | |
| Refer to price schedule for selection | 1 | TUBING SIZES AND MATERIALS ARE LISTED |
| ITEM NO. 11: BLEED VALVE ASSEMBLY (STANDARD) | | |
| Refer to price schedule for selection | 1 | TUBING SIZES AND MATERIALS ARE LISTED |
| ITEM NO. 12: FOOT VALVE/STRAINER ASSEMBLY | | |
| Refer to price schedule for selection | 1 | TUBING SIZES AND MATERIALS ARE LISTED |
| ITEM NO. 13: INJECTION/BACK PRESSURE VALVE | | |
| Refer to price schedule for selection | 1 | TUBING SIZES AND MATERIALS ARE LISTED |
| ITEM NO. 18: SUCTION /DISCHARGE O-RING | | |
| L1501300-HYP | 1 EACH | ALL MODELS |
| L1501300-TFE | 1 EACH | ALL MODELS |
| L1501300-VTN | 1 EACH | ALL MODELS |
| L1501300-EPB | 1 EACH | ALL MODELS |
| ITEM NO. 36: BLEED VALVE O-RING | | |
| L1501200-HYP | 1 | ALL MODELS |
| L1501200-TFE | 1 | ALL MODELS |
| L1501200-VTN | 1 | ALL MODELS |
| L1501200-EPB | 1 | ALL MODELS |

12000, 13000 AND 14000 XV SERIES DRIVE ASSEMBLY AND CONTROL PANEL PARTS IDENTIFICATION

| PART NO. | QUANTITY | VOLTAGE | MODEL VP (DIGITS 3, 4) |
|----------|----------|---------|------------------------|
|----------|----------|---------|------------------------|

ITEM 51: HOUSING

| | | | |
|--------------|---|---|--------------------------------|
| L0500100-080 | 1 | - | H4, H5, H6, H7, H8, K7 |
| L0500200-040 | 1 | - | A2, A3, B2, B3, B4, D3, D4, F4 |
| L0500200-080 | 1 | - | E4, G4, G5 |

ITEM 52: ELECTRONIC CONTROL BOARD - STANDARD (DUAL FUNCTION)

| | | | |
|--------------|---|------|--------------------------------|
| L0700101-125 | 1 | 115V | A2, A3, B2, B3, B4, D3, D4, E4 |
| L0700102-125 | 1 | 230V | A2, A3, B2, B3, B4, D3, D4, E4 |
| L0700501-150 | 1 | 115V | F4, G4, G5 |
| L0700502-150 | 1 | 230V | F4, G4, G5 |
| L0700501-200 | 1 | 115V | H4, H5, H6, H7, H8, K7 |
| L0700502-200 | 1 | 230V | H4, H5, H6, H7, H8, K7 |

ITEM 52: ELECTRONIC CONTROL BOARD - EXT/STOP FUNCTION

| | | | |
|--------------|---|------|--------------------------------|
| L0700201-125 | 1 | 115V | A2, A3, B2, B3, B4, D3, D4, E4 |
| L0700202-125 | 1 | 230V | A2, A3, B2, B3, B4, D3, D4, E4 |
| L0700801-150 | 1 | 115V | F4, G4, G5 |
| L0700802-150 | 1 | 230V | F4, G4, G5 |
| L0700801-200 | 1 | 115V | H4, H5, H6, H7, H8, K7 |
| L0700802-200 | 1 | 230V | H4, H5, H6, H7, H8, K7 |

ITEM NO. 52: ELECTRONIC CONTROL BOARD - 4-20MA/STOP FUNCTION

| | | | |
|--------------|---|------|--------------------------------|
| L0700401-125 | 1 | 115V | A2, A3, B2, B3, B4, D3, D4, E4 |
| L0700402-125 | 1 | 230V | A2, A3, B2, B3, B4, D3, D4, E4 |
| L0700901-150 | 1 | 115V | F4, G4, G5 |
| L0700902-150 | 1 | 230V | F4, G4, G5 |
| L0700901-200 | 1 | 115V | H4, H5, H6, H7, H8, K7 |
| L0700902-200 | 1 | 230V | H4, H5, H6, H7, H8, K7 |

ITEM NO. 54: DUST COVER ASSEMBLY

| | | | |
|--------------|---|---|--|
| L1600500-000 | 1 | - | A2, A3, B2, B3, B4, D3, D4, E4, F4, G4, G5 |
| L1600400-000 | 1 | - | H4, H5, H6, H7, H8, K7 |

ITEM NO. 55: FEMALE ADJUSTMENT SHAFT

| | | | |
|--------------|---|---|------------------------------------|
| L2000100-040 | 1 | - | A2, A3, B2, B3, B4, D3, D4, F4 |
| L2000100-080 | 1 | - | E4, G4, G5, H4, H5, H6, H7, H8, K7 |

ITEM NO. 58: O-RING EPM/HOUSING

| | | | |
|--------------|---|---|--|
| L1500400-NTR | 1 | - | A2, A3, B2, B3, B4, D3, D4, E4, F4, G4, G5 |
| L1500600-NTR | 1 | - | H4, H5, H6, H7, H8, K7 |

ITEM NO. 60: SECONDARY SEAL

| | | | |
|--------------|---|---|------------|
| L1500700-NTR | 1 | - | ALL MODELS |
|--------------|---|---|------------|

12000, 13000 AND 14000 XV SERIES DRIVE ASSEMBLY AND CONTROL PANEL (CONT.) PARTS IDENTIFICATION

| PART NO. | QUANTITY | VOLTAGE | MODEL VP (DIGITS 3, 4) |
|---|----------|-----------|--------------------------------|
| ITEM NO. 62: POWER CORD | | | |
| L9701200-000 | 1 | 115V | ALL MODELS |
| L9701300-000 | 1 | 230V | ALL MODELS |
| ITEM NO. 63: OVERLOAD DEVICE (CIRCUIT BREAKER) | | | |
| L9700700-250 | 1 | 115V/230V | ALL MODELS |
| ITEM NO.65: GROMMET STROKE RATE/SWITCH | | | |
| L1500800-NTR | 2 | - | ALL MODELS |
| ITEM NO. 66: KNOB, STROKE RATE/SWITCH | | | |
| L1900200-000 | 2 | - | ALL MODELS |
| ITEM NO. 70: LOCKING TAB | | | |
| L9700500-000 | 1 | - | ALL MODELS |
| ITEM NO. 71: KNOB, STROKE LENGTH | | | |
| L1900100-FPP | 1 | - | ALL MODELS |
| ITEM NO. 81: CONTROL PANEL ASSEMBLY - STANDARD (DUAL FUNCTION) | | | |
| L5000801-115 | 1 | 115V | A2, A3, B2, B3, B4, D3, D4, E4 |
| L5000801-230 | 1 | 230V | A2, A3, B2, B3, B4, D3, D4, E4 |
| L5000301-115 | 1 | 115V | F4, G4, G5 |
| L5000301-230 | 1 | 230V | F4, G4, G5 |
| L5001301-115 | 1 | 115V | H4, H5, H6, H7, H8 |
| L5001301-230 | 1 | 230V | H4, H5, H6, H7, H8 |
| L5003701-115 | 1 | 115V | K7 |
| L5003701-230 | 1 | 230V | K7 |
| ITEM NO. 81: CONTROL PANEL ASSEMBLY - EXT./STOP FUNCTION | | | |
| L5000901-115 | 1 | 115V | A2, A3, B2, B3, B4, D3, D4, E4 |
| L5000901-230 | 1 | 230V | A2, A3, B2, B3, B4, D3, D4, E4 |
| L5000401-115 | 1 | 115V | F4, G4, G5 |
| L5000401-230 | 1 | 230V | F4, G4, G5 |
| L5001401-115 | 1 | 115V | H4, H5, H6, H7, H8 |
| L5001401-230 | 1 | 230V | H4, H5, H6, H7, H8 |
| L5003801-115 | 1 | 115V | K7 |
| L5003801-230 | 1 | 230V | K7 |
| ITEM NO. 81: CONTROL PANEL ASSEMBLY 4-20 MA/STOP | | | |
| L5001001-115 | 1 | 115V | A2, A3, B2, B3, B4, D3, D4, E4 |
| L5001001-230 | 1 | 230V | A2, A3, B2, B3, B4, D3, D4, E4 |
| L5000501-115 | 1 | 115V | F4, G4, G5 |
| L5000501-230 | 1 | 230V | F4, G4, G5 |
| L5001501-115 | 1 | 115V | H4, H5, H6, H7, H8 |
| L5001501-230 | 1 | 230V | H4, H5, H6, H7, H8 |
| L5003901-115 | 1 | 115V | K7 |
| L5003901-230 | 1 | 230V | K7 |
| ITEM NO. 85: STOP/FUNC. CORDS | | | |
| L9700200-000 | 2 | - | ALL MODELS |
| ITEM NO. 92: BREAKER COVER | | | |
| L9700800-000 | 1 | - | ALL MODELS |

1000D, 1000S AND 1100 XV SERIES WETTED COMPONENT ASSEMBLIES PARTS IDENTIFICATION

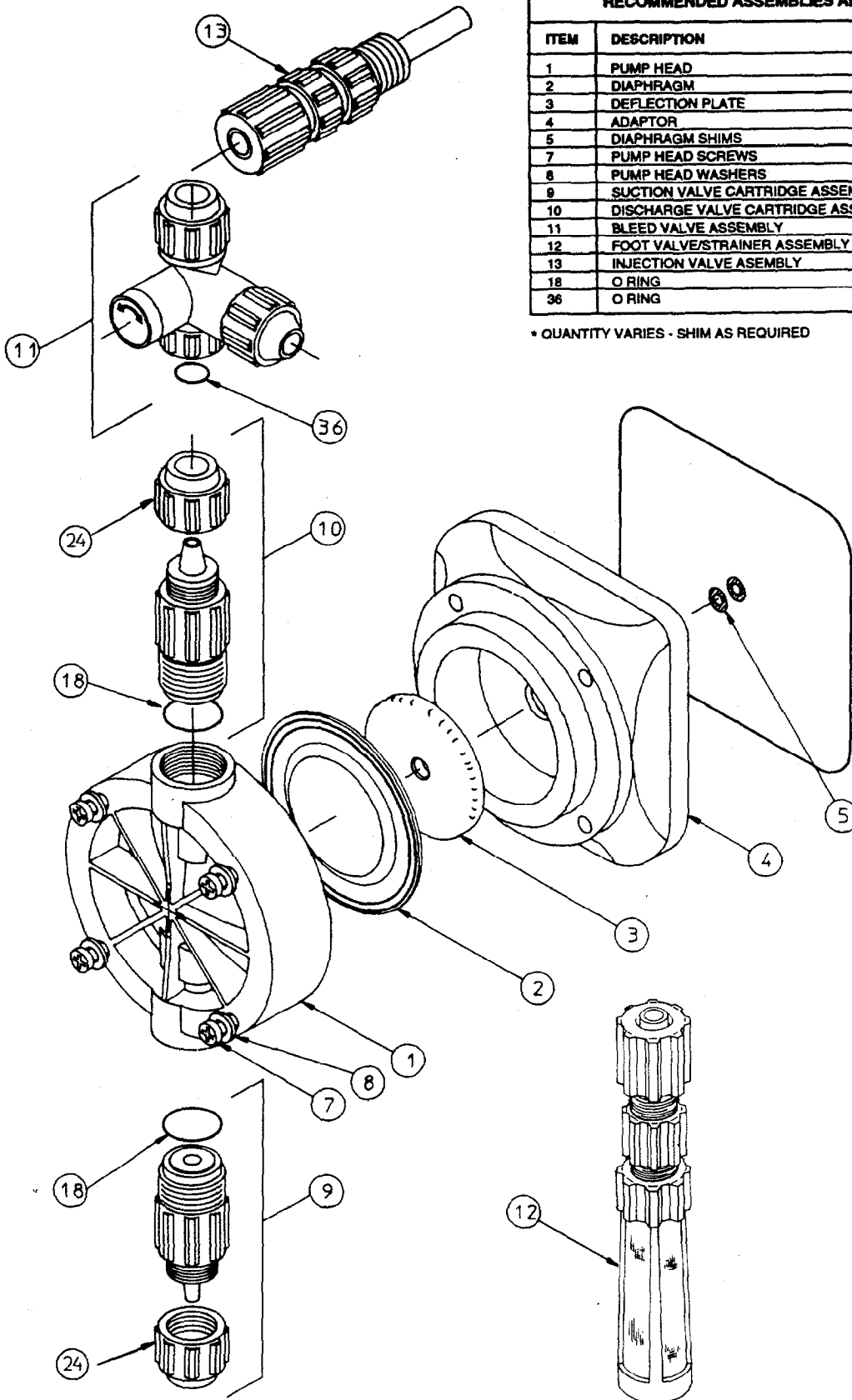

| RECOMMENDED ASSEMBLIES AND PARTS | | |
|----------------------------------|------------------------------------|------|
| ITEM | DESCRIPTION | QTY |
| 1 | PUMP HEAD | 1 |
| 2 | DIAPHRAGM | 1 |
| 3 | DEFLECTION PLATE | 1 |
| 4 | ADAPTOR | 1 |
| 5 | DIAPHRAGM SHIMS | *0-2 |
| 7 | PUMP HEAD SCREWS | 4 |
| 8 | PUMP HEAD WASHERS | 4 |
| 9 | SUCTION VALVE CARTRIDGE ASSEMBLY | 1 |
| 10 | DISCHARGE VALVE CARTRIDGE ASSEMBLY | 1 |
| 11 | BLEED VALVE ASSEMBLY | 1 |
| 12 | FOOT VALVE/STRAINER ASSEMBLY | 1 |
| 13 | INJECTION VALVE ASSEMBLY | 1 |
| 18 | O RING | 2 |
| 36 | O RING | 1 |

* QUANTITY VARIES - SHIM AS REQUIRED

10000D, 10000S AND 11000 XV SERIES DRIVE ASSEMBLY AND CONTROL PANEL PARTS IDENTIFICATION

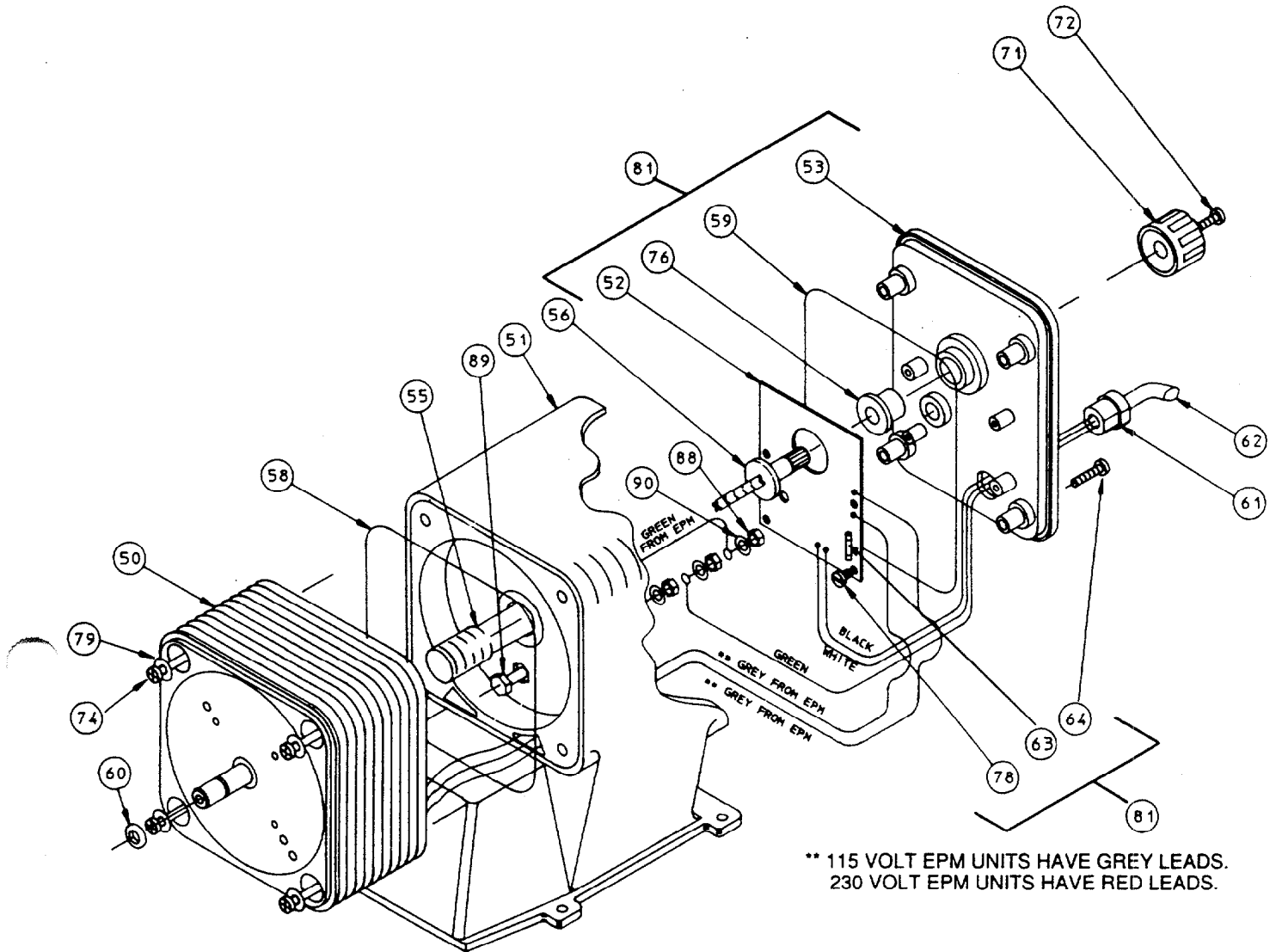

SERIES 10000D, 10000S AND 11000 XV

| REPLACEMENT ASSEMBLIES AND PARTS | | |
|----------------------------------|--------------------------|-----|
| ITEM | DESCRIPTION | QTY |
| 50 | EPM | 1 |
| 51 | HOUSING | 1 |
| 52 | ELECTRONIC CONTROL BOARD | 1 |
| 53 | CONTROL PANEL | 1 |
| 55 | FEMALE ADJUSTMENT SHAFT | 1 |
| 56 | MALE ADJUSTMENT SHAFT | 1 |
| 58 | EPM/HOUSING O-RING | 1 |
| 59 | CONTROL PANEL O-RING | 1 |
| 60 | SECONDARY SEAL | 1 |
| 61 | STRAIN RELIEF | 1 |
| 62 | POWER CORD | 1 |
| 63 | FUSE | 1 |
| 64 | CONTROL PANEL SCREW* | 4 |

| REPLACEMENT ASSEMBLIES AND PARTS | | |
|----------------------------------|--------------------------------|-----|
| ITEM | DESCRIPTION | QTY |
| 68 | KNOB SET SCREW | 2 |
| 71 | KNOB, STROKE LENGTH | 1 |
| 72 | KNOB MOUNTING SCREW | 1 |
| 73 | KNOB STICKER STROKE LENGTH | 1 |
| 74 | EPM MOUNTING SCREW | 4 |
| 76 | GROMMET STROKE LENGTH | 1 |
| 78 | ELECTRONIC CONTROL BOARD SCREW | 2 |
| 79 | EPM MOUNTING WASHER | 4 |
| 81 | CONTROL PANEL ASSEMBLY | 1 |
| 88 | GROUND LUG NUT | 3 |
| 89 | GROUND LUG BOLT | 1 |
| 90 | GROUND LUG WASHER | 3 |

PARTS NOT SHOWN FOR SERIES 10000D XV AND 11000 XV.

| | | |
|----|-----------------------------|---|
| 65 | GROMMET, STROKE RATE/SWITCH | 1 |
| 66 | KNOB, STROKE RATE/SWITCH | |

10000D, 10000S AND 11000 XV SERIES WETTED COMPONENT ASSEMBLIES PARTS IDENTIFICATION

- Product Class: 10000D=VD, 10000S=VC, 11000=VB
- Digit 3, 4 are provided in charts for proper model identification.
- Complete model information is published in price schedules PCP-PSLX 0193.
- When X appears under a product class it signifies part is not used or available.

| PART NO. | QUANTITY | VC, VD MODELS (DIGIT 3, 4) | VB MODELS (DIGIT 3, 4) |
|----------|----------|-------------------------------|---------------------------|
|----------|----------|-------------------------------|---------------------------|

ITEM NO. 1: PUMP HEAD (GFPPPL)

| | | | |
|--------------|---|--------|--------|
| L0200200-FPP | 1 | 02 | 02 |
| L0200300-FPP | 1 | 03 | 03 |
| L0200400-FPP | 1 | 04, 54 | 04, 64 |

ITEM NO. 1: PUMP HEAD (PVC)

| | | | |
|--------------|---|--------|--------|
| L0200200-HPV | 1 | 02 | 02 |
| L0200300-PVC | 1 | 03 | X |
| L0200400-PVC | 1 | 04, 54 | 04, 64 |
| L0200300-HPV | 1 | X | 03 |

ITEM NO. 1: PUMP HEAD (SAN)

| | | | |
|--------------|---|--------|--------|
| L0200300-SAN | 1 | 03 | X |
| L0200400-SAN | 1 | 04, 54 | 04, 64 |

ITEM NO. 1: PUMP HEAD (PVDF)

| | | | |
|--------------|---|--------|--------|
| L0200200-PVD | 1 | 02 | 02 |
| L0200300-PVD | 1 | 03 | 03 |
| L0200400-PVD | 1 | 04, 54 | 04, 64 |

ITEM NO. 1: PUMP HEAD (S.S. 316)

| | | | |
|--------------|---|--------|--------|
| L0200200-316 | 1 | 02 | 02 |
| L0200300-316 | 1 | 03 | 03 |
| L0200400-316 | 1 | 04, 54 | 04, 64 |

ITEM NO. 2: DIAPHRAGM

| | | | |
|--------------|---|--------|--------|
| L0300900-THY | 1 | 02 | 02 |
| L0301000-THY | 1 | 03 | 03 |
| L0301100-THY | 1 | 04, 54 | 04, 64 |

ITEM NO. 3: DEFLECTION PLATE

| | | | |
|--------------|---|--------|--------|
| L2100200-FPP | 1 | 02 | 02 |
| L2100300-FPP | 1 | 03 | 03 |
| L2100400-FPP | 1 | 04, 54 | 04, 64 |

ITEM NO. 4: ADAPTOR

| | | | |
|--------------|---|--------|--------|
| L0401100-FPP | 1 | 02 | 02 |
| L0401200-FPP | 1 | 03 | 03 |
| L0401300-FPP | 1 | 04, 54 | 04, 64 |

ITEM NO. 5: DIAPHRAGM SHIMS

| | | | |
|--------------|-----|------------|------------|
| L9901200-BRS | 0-2 | ALL MODELS | ALL MODELS |
|--------------|-----|------------|------------|

ITEM NO. 7: PUMP HEAD SCREWS

| | | | |
|-------------------------|---|------------|------------|
| L9801700-188 | 4 | ALL MODELS | ALL MODELS |
| L9803300-188 (316 HEAD) | 4 | 03, 04, 54 | 03, 04, 64 |

ITEM NO. 8: PUMP HEAD WASHERS

| | | | |
|--------------|---|------------|------------|
| L9801300-188 | 4 | ALL MODELS | ALL MODELS |
|--------------|---|------------|------------|

10000D, 10000S AND 11000 XV SERIES WETTED COMPONENT ASSEMBLIES (CONT.) PARTS IDENTIFICATION

| PART NO. | QUANTITY | VC, VD MODELS (DIGIT 3, 4) | VB MODEL (DIGIT 3, 4) |
|---|----------|---------------------------------------|--------------------------|
| ITEM NO. 9: SUCTION VALVE ASSEMBLY | | | |
| Refer to price schedule for selection | 1 | TUBING SIZES AND MATERIALS ARE LISTED | |
| ITEM NO. 10: DISCHARGE VALVE ASSEMBLY | | | |
| Refer to price schedule for selection | 1 | TUBING SIZES AND MATERIALS ARE LISTED | |
| ITEM NO. 11: BLEED VALVE ASSEMBLY | | | |
| Refer to price schedule for selection | 1 | TUBING SIZES AND MATERIALS ARE LISTED | |
| ITEM NO. 12: FOOT VALVE/STRAINER ASSEMBLY | | | |
| Refer to price schedule for selection | 1 | TUBING SIZES AND MATERIALS ARE LISTED | |
| ITEM NO. 13: INJECTION/BACK PRESSURE VALVE | | | |
| Refer to price schedule for selection | 1 | TUBING SIZES AND MATERIALS ARE LISTED | |
| ITEM NO. 18: SUCTION/DISCHARGE O-RING | | | |
| L1501300-HYP | 1 EACH | ALL MODELS | ALL MODELS |
| L1501300-TFE | 1 EACH | ALL MODELS | ALL MODELS |
| L1501300-VTN | 1 EACH | ALL MODELS | ALL MODELS |
| L1501300-EPB | 1 EACH | ALL MODELS | ALL MODELS |
| ITEM NO. 36: BLEED VALVE O-RING | | | |
| L1501200-HYP | 1 | ALL MODELS | ALL MODELS |
| L1501200-TFE | 1 | ALL MODELS | ALL MODELS |
| L1501200-VTN | 1 | ALL MODELS | ALL MODELS |
| L1501200-EPB | 1 | ALL MODELS | ALL MODELS |

10000D, 10000S AND 11000 XV SERIES DRIVE ASSEMBLY AND CONTROL PANEL PARTS IDENTIFICATION

| PART NO. | QUANTITY | VOLTAGE | VC, VD MODELS (DIGIT 3, 4) | VB MODEL (DIGIT 3, 4) |
|--|----------|---------|-------------------------------|--------------------------|
| ITEM NO. 51: ADAPTOR | | | | |
| L0500300-040 | 1 | - | 02, 03, 04 | 02, 03, 04 |
| L0500300-080 | 1 | - | 54 | 64 |
| ITEM NO. 52: ELECTRONIC CONTROL BOARD (DUAL FUNCTION) | | | | |
| L0700701-125 | 1 | 115V | ALL MODELS | ALL MODELS |
| L0700702-125 | 4 | 230V | ALL MODELS | ALL MODELS |
| ITEM NO. 52: ELECTRONIC CONTROL BOARD (SINGLE FUNCTION) FIXED FREQUENCY | | | | |
| L0701801-120 | 1 | 115V | ALL MODELS | X |
| L0701802-120 | 1 | 230V | ALL MODELS | X |

1000D, 1000S AND 1100 XV SERIES DRIVE ASSEMBLY AND CONTROL PANEL (CONT.) PARTS IDENTIFICATION

| PART NO. | QUANTITY | VOLTAGE | VC, VD MODELS (DIGIT 3, 4) | VB MODEL (DIGIT 3, 4) |
|--|----------|-----------|-------------------------------|--------------------------|
| ITEM NO. 55: FEMALE ADJUSTMENT SHAFT | | | | |
| L2000200-040 | 1 | - | 02, 03, 04 | 02, 03, 04 |
| L2000200-080 | 1 | - | 54 | 64 |
| ITEM NO. 58: O-RING, EMP/HOUSING | | | | |
| L1500200-NTR | 1 | - | ALL MODELS | 02, 03, 04 |
| L1500400-NTR | 1 | - | X | 64 |
| ITEM NO. 60: SECONDARY SEAL | | | | |
| L1500700-NTR | 1 | - | ALL MODELS | ALL MODELS |
| ITEM NO. 61: STRAIN RELIEF | | | | |
| L9900700-000 | 1 | - | ALL MODELS | ALL MODELS |
| ITEM NO. 62: POWER CORD | | | | |
| L9700300-000 | 1 | 115V | ALL MODELS | ALL MODELS |
| L9700400-000 | 1 | 230V | ALL MODELS | ALL MODELS |
| ITEM NO. 63: OVERLOAD DEVICE (FUSE) | | | | |
| L9701500-150 | 1 | 115V/230V | ALL VD MODELS | ALL MODELS |
| ITEM NO. 65: GROMMET, STROKE RATE/SWITCH | | | | |
| L1500800-NTR | 1 | - | ALL VD MODELS | ALL MODELS |
| ITEM NO. 66: KNOB, STROKE RATE/SWITCH | | | | |
| L1900200-000 | 1 | - | ALL VD MODELS | ALL MODELS |
| ITEM NO. 71: KNOB, STROKE LENGTH | | | | |
| L1900300-FPP | 1 | - | ALL MODELS | ALL MODELS |
| ITEM NO. 81: CONTROL PANEL ASSEMBLY (DUAL FUNCTION) | | | | |
| L5000100-115 | 1 | 115V | 02, 03, 04 | 02, 03, 04 |
| L5000100-230 | 1 | 230V | 02, 03, 04 | 02, 03, 04 |
| L5004100-115 | 1 | 115V | 54 | 64 |
| L5004100-230 | 1 | 230V | 54 | 64 |
| ITEM NO. 81: CONTROL PANEL ASSEMBLY (SINGLE FUNCTION) FIXED FREQ. | | | | |
| L5002900-115 | 1 | 115V | 02, 03, 04 | X |
| L5002900-230 | 1 | 230V | 02, 03, 04 | X |
| L5003000-115 | 1 | 115V | 54 | X |
| L5003000-230 | 1 | 230V | 54 | X |

APPENDIX H

SECTION 5

PUMP DATA

PUMP P-143

Manufacturer: Wilden
Model: M4 Metal
Vendor: Industrial Sales
Phone Number: (800) 672-0446



WILDEN®

AIR OPERATED DOUBLE DIAPHRAGM PUMPS

M4 Engineering Operation and Maintenance

MODEL M4 METAL
MODEL M4 CHAMP
MODEL M4 FOOD PROCESSING
MODEL M4 ULTRAPURE

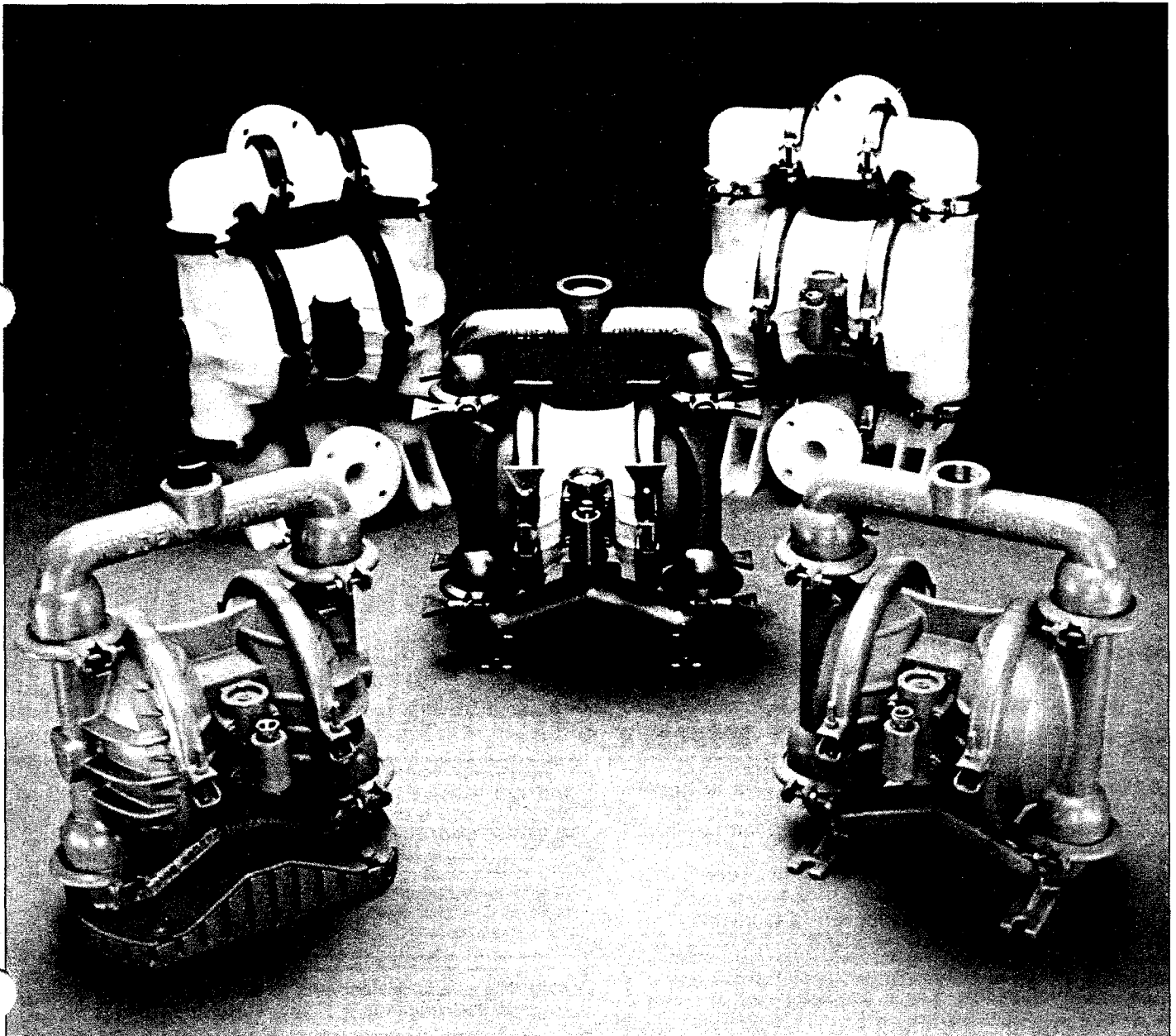

THE WILDEN PUMP — HOW IT WORKS

The Wilden diaphragm pump is an air-operated, positive displacement, self-priming pump. These drawings show flow pattern through the pump upon its initial stroke. It is assumed the pump has no fluid in it prior to its initial stroke.

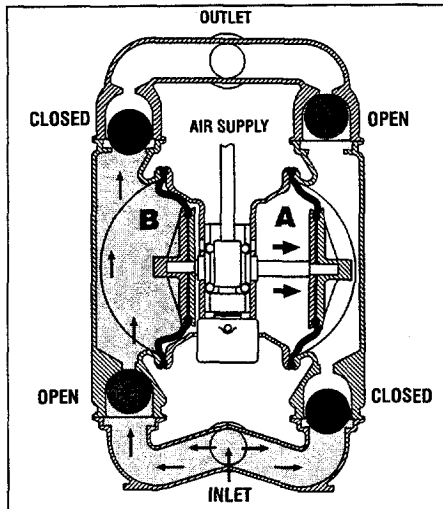

FIGURE 1 The air valve directs pressurized air to the back side of diaphragm A. The compressed air is applied directly to the liquid column separated by elastomer diaphragms. The diaphragm acts as a separation membrane between the compressed air and liquid, balancing the load and removing mechanical stress from the diaphragm which allows for millions of flex cycles. The compressed air moves the diaphragm away from the center block of the pump. The opposite diaphragm is pulled in by the shaft connected to the pressurized diaphragm. Diaphragm B is now on its suction stroke; air behind the diaphragm has been forced out to the atmosphere through the exhaust port of the pump. Diaphragm A is working against atmospheric air pressure. The movement of diaphragm B toward the center block of the pump creates a vacuum within chamber B. Atmospheric pressure forces fluid into the inlet manifold forcing the inlet valve ball off its seat. Liquid is free to move past the inlet valve ball and fill the liquid chamber.

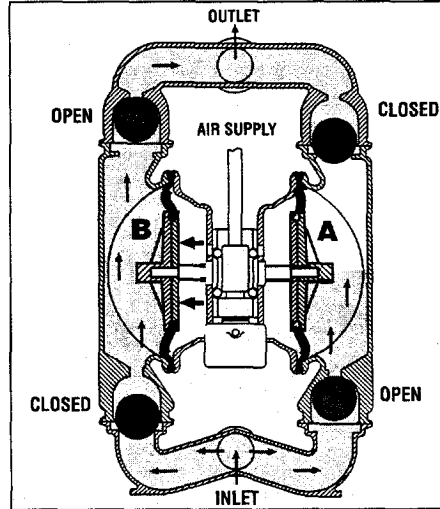

FIGURE 2 When the pressurized diaphragm, diaphragm A, reaches the limit of its discharge stroke, the air valve redirects pressurized air to the back side of diaphragm B. The pressurized air forces diaphragm B away from the center block while pulling diaphragm A to the center block. Diaphragm B is now on its discharge stroke. Diaphragm B forces the inlet valve ball onto its seat due to the hydraulic forces developed in the liquid chamber and manifold of the pump. These same hydraulic forces lift the discharge valve ball off its seat, while the opposite discharge valve ball is forced onto its seat, forcing fluid to flow through the pump discharge. The movement of diaphragm A to the center block of the pump creates a vacuum within liquid chamber A. Atmospheric pressure forces fluid into the inlet manifold of the pump. The inlet valve ball is forced off its seat allowing the fluid being pumped to fill the liquid chamber.

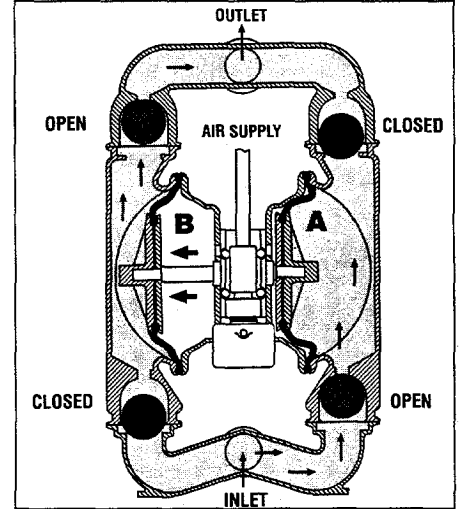
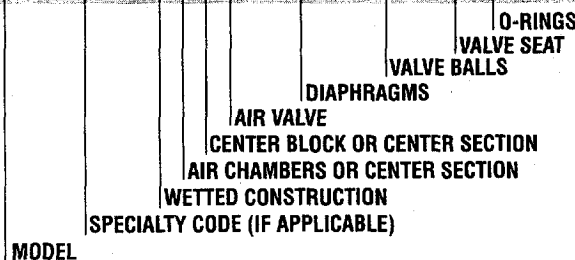

FIGURE 3 At completion of the stroke, the air valve again redirects air to the back side of diaphragm A, which starts diaphragm B on its exhaust stroke. As the pump reaches its original starting point, each diaphragm has gone through one exhaust and one discharge stroke. This constitutes one complete pumping cycle. The pump may take several cycles to completely prime depending on the conditions of the application.



WILDEN PUMP DESIGNATION SYSTEM

M XXX-xxx / XXXX / XX / XX / XXX



In the case where a center section is used instead of a center block and air chambers, the designation will be as follows:
Aluminum = AA, Polypropylene = PP, Carbon-filled Acetal = GG, Nylon = YY, Acetal = LL

SUGGESTED INSTALLATION

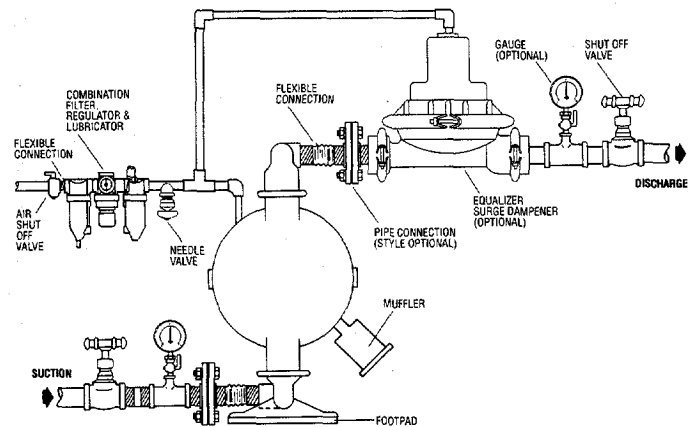

CAUTIONS! READ FIRST

NOTE: UL-listed pumps must not exceed 50 psig air supply pressure.

Temperature Limits:

| | | |
|---------------|-----------------|----------------|
| Polypropylene | +32°F to +175°F | 0°C to 79°C |
| PVDF | +10°F to +225°F | -12°C to 107°C |
| Teflon® PFA | +20°F to +225°F | 7°C to 107°C |

CAUTION: Maximum temperature limits are based upon mechanical stress only. Certain chemicals will significantly reduce maximum safe operating temperatures. Consult engineering guide for chemical compatibility and temperature limits.

WARNING: Prevention of static sparking — If static sparking occurs, fire or explosion could result. Pump, valves, and containers must be grounded when handling flammable fluids and whenever discharge of static electricity is a hazard. To ground the Wilden "Champ," all clamp bands must be grounded to a proper grounding point.

CAUTION: ALWAYS WEAR SAFETY GLASSES WHEN OPERATING PUMP. WHEN DIAPHRAGM RUPTURE OCCURS, MATERIAL BEING PUMPED MAY BE FORCED OUT AIR EXHAUST.

"Champ" series pumps are made of virgin plastic and are not UV stabilized. Direct sunlight for prolonged periods can cause deterioration of plastics.

NOTE: Pump must be lubricated. Wilden suggests an arctic 5 weight oil (ISO grade 15).

TABLE OF CONTENTS

| | PAGE # |
|--|--------|
| SECTION # 1 — DIMENSIONAL DRAWINGS | |
| A. Model M4 METAL | 2 |
| B. Model M4 FOOD PROCESSING..... | 3 |
| C. Model M4 CHAMP and ULTRAPURE | 4 |
| SECTION # 2 — PERFORMANCE CURVES / TECHNICAL DATA | |
| A. METAL M4 (Rubber/TPE-fitted)..... | 5 |
| B. METAL M4 (Teflon-fitted) | 5 |
| C. CHAMP M4 (Rubber/TPE-fitted)..... | 6 |
| D. CHAMP M4 (Teflon-fitted) | 6 |
| SECTION # 3 — INSTALLATION | |
| | 7 |
| SECTION # 4 — SUGGESTED OPERATION AND MAINTENANCE | |
| | 7 |
| SECTION # 5 — TROUBLESHOOTING | |
| | 8 |
| SECTION # 6 — DIRECTIONS FOR DISASSEMBLY / REASSEMBLY | |
| A. Model M4 METAL | 9-13 |
| B. Model M4 CHAMP | 14-20 |
| C. Air valve/center block disassembly/reassembly | 21-22 |
| D. Air valve/center section maintenance (Turbo) | 23 |
| SECTION # 7 — EXPLODED VIEW / PARTS LISTING | |
| A. Model M4 METAL (Rubber/TPE-fitted) | 24-25 |
| B. Model M4 METAL (Teflon®-fitted) | 26 |
| C. Model M4 CHAMP | 27-28 |
| SECTION # 8 — ELASTOMER OPTIONS / TORQUE SPECIFICATIONS | |
| | 29 |

CAUTION: DO NOT EXCEED 125 PSIG AIR SUPPLY PRESSURE. (50 PSI ON UL MODELS.)

CAUTION: Before any maintenance or repair is attempted, the compressed air line to the pump should be disconnected and all air pressure allowed to bleed from pump. Disconnect all intake, discharge, and air lines. Drain the pump by turning it upside down and allowing any fluid to flow into a suitable container.

BLOW OUT AIR LINE FOR 10 TO 20 SECONDS BEFORE ATTACHING TO PUMP TO MAKE SURE ALL PIPE LINE DEBRIS IS CLEAR. USE AN IN-LINE AIR FILTER.

NOTE: When installing Teflon® diaphragms, it is important to tighten outer pistons simultaneously (turning in opposite direction) to ensure a tight fit.

CAUTION: When removing the end cap using compressed air, the air valve end cap may come out with considerable force. Hand protection such as a padded glove or a rag should be used to capture the end cap.

NOTE: Before starting disassembly, mark a line from each liquid chamber to its corresponding air chamber. This line will assist in proper alignment during reassembly.

NOTE: On pumps equipped with Teflon® diaphragms, balls, and sealing rings, Teflon® gaskets should be used between the flanges of the manifold.

NOTE: AIR VALVE AND CENTER SECTION DISASSEMBLY/ REASSEMBLY IS SHOWN IN SECTION 6C.

SECTION 1A

DIMENSIONAL DRAWING MODEL M4 METAL PUMP

CAST IRON, STAINLESS STEEL & HASTELLOY
1 1/4" NPT (FEMALE)

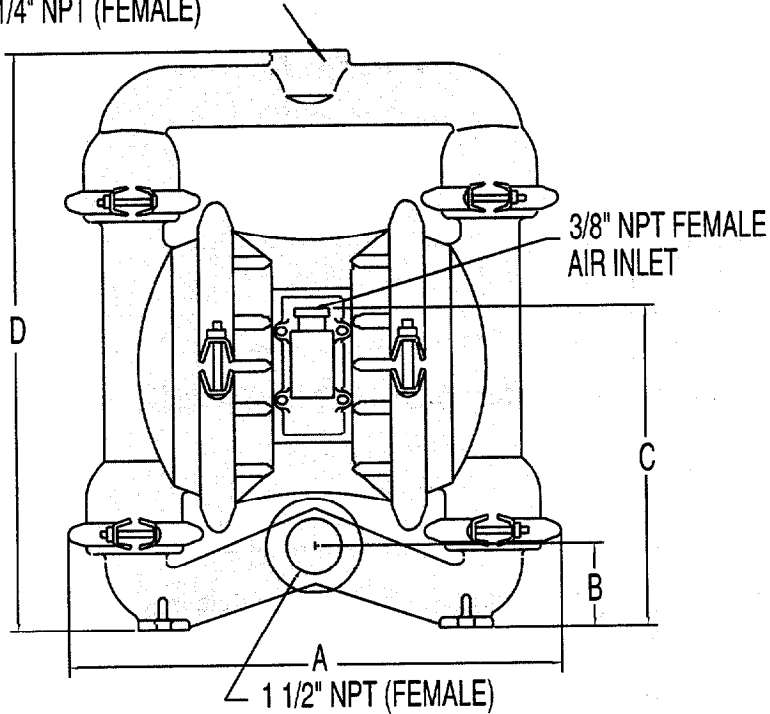

ALUM. - 1 1/4" NPT (MALE)

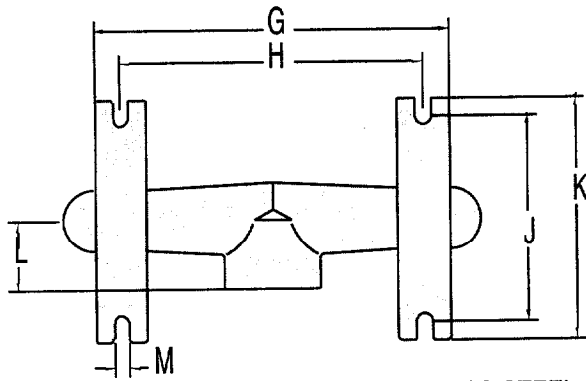
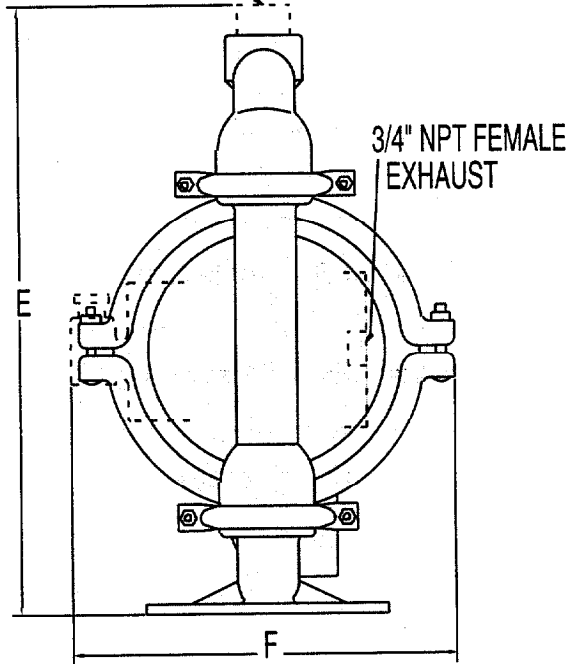

FOOTED BASE FOR STAINLESS STEEL &
HASTELLOY MODELS

BASE FOR ALUMINUM &
CAST IRON MODELS

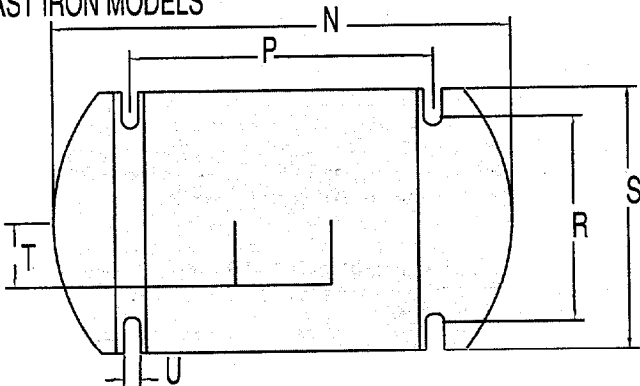

| DIMENSIONS - M4 (METAL) | | |
|-------------------------|-----------------|-------------|
| ITEM | STANDARD (inch) | METRIC (mm) |
| A | 14 17/32 | 369.1 |
| B | 2 15/32 | 62.7 |
| C | 9 9/32 | 235.8 |
| D | 16 7/8 | 428.6 |
| E | 17 7/8 | 454.0 |
| F | 11 5/16 | 287.4 |
| G | 10 5/16 | 261.9 |
| H | 8 3/16 | 223.8 |
| J | 6 | 152.4 |
| K | 7 | 177.8 |
| L | 2 | 50.8 |
| M | 7/16 | 11.1 |
| N | 13 7/32 | 335.7 |
| P | 8 3/4 | 222.3 |
| R | 5 15/16 | 150.8 |
| S | 7 21/32 | 194.5 |
| T | 1 29/32 | 48.4 |
| U | 1/2 | 12.7 |

BSP threads available.
Standard aluminum pumps are manufactured with mild steel nipples. Stainless steel nipples are available.

SECTION 1B

DIMENSIONAL DRAWING MODEL M4 FOOD PROCESSING PUMP

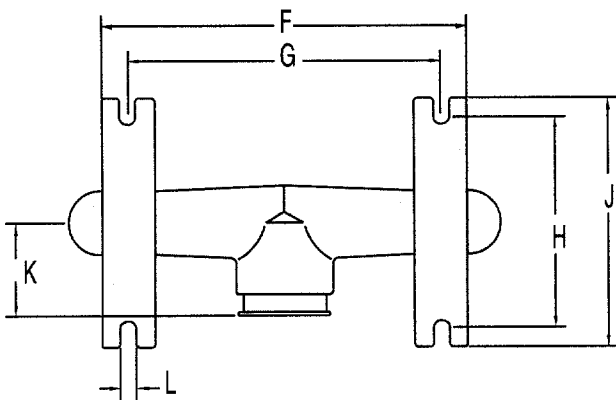
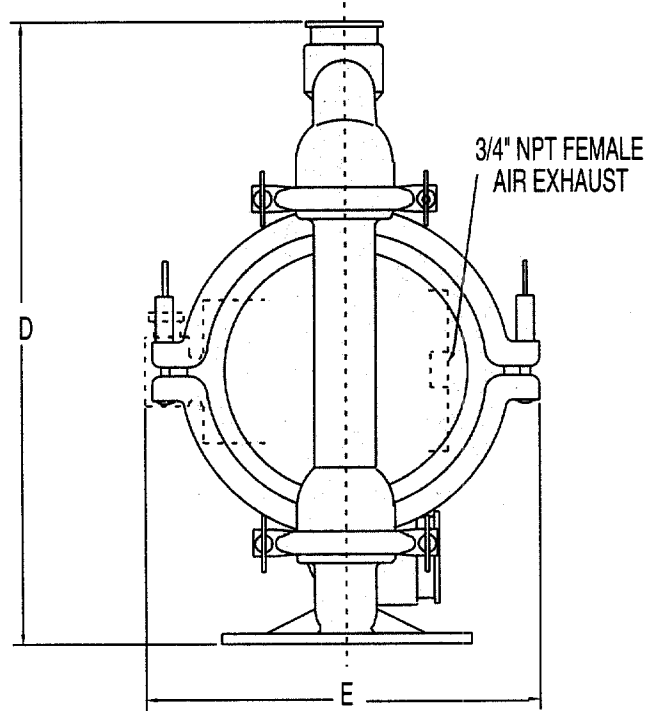
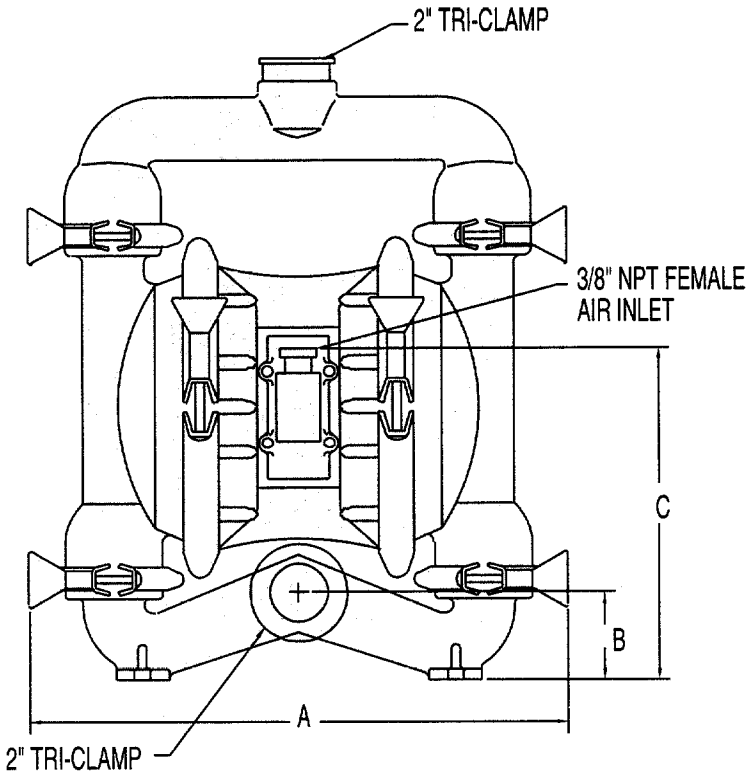

| DIMENSIONS - M4 (FOOD GRADE) | | |
|------------------------------|-----------------|-------------|
| ITEM | STANDARD (inch) | METRIC (mm) |
| A | 15 3/8 | 390.5 |
| B | 2 15/32 | 62.7 |
| C | 9 1/8 | 231.8 |
| D | 17 13/32 | 442.1 |
| E | 11 7/32 | 285.0 |
| F | 10 9/32 | 261.2 |
| G | 8 13/16 | 223.8 |
| H | 5 31/32 | 151.6 |
| J | 7 | 177.8 |
| K | 2 5/8 | 66.7 |
| L | 7/16 | 11.1 |

SECTION 1C

DIMENSIONAL DRAWING MODEL M4 CHAMP AND ULTRAPURE PUMP

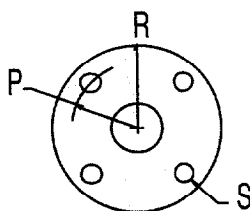
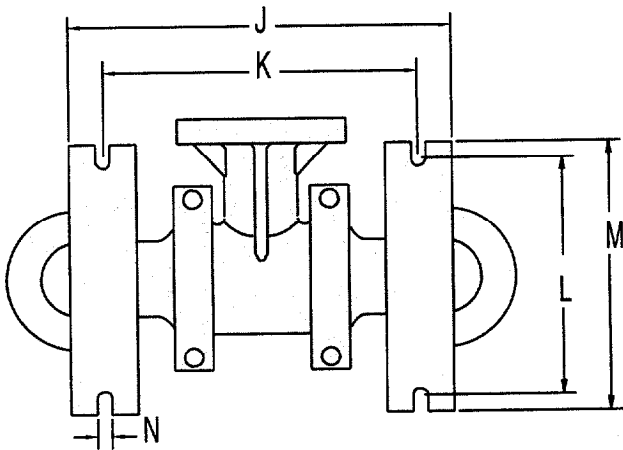
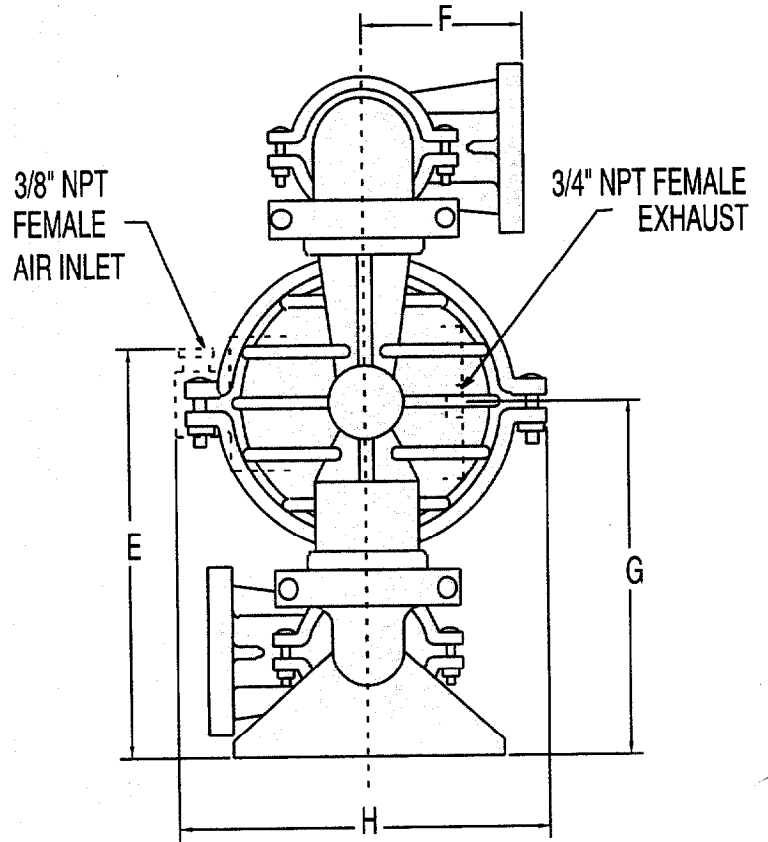
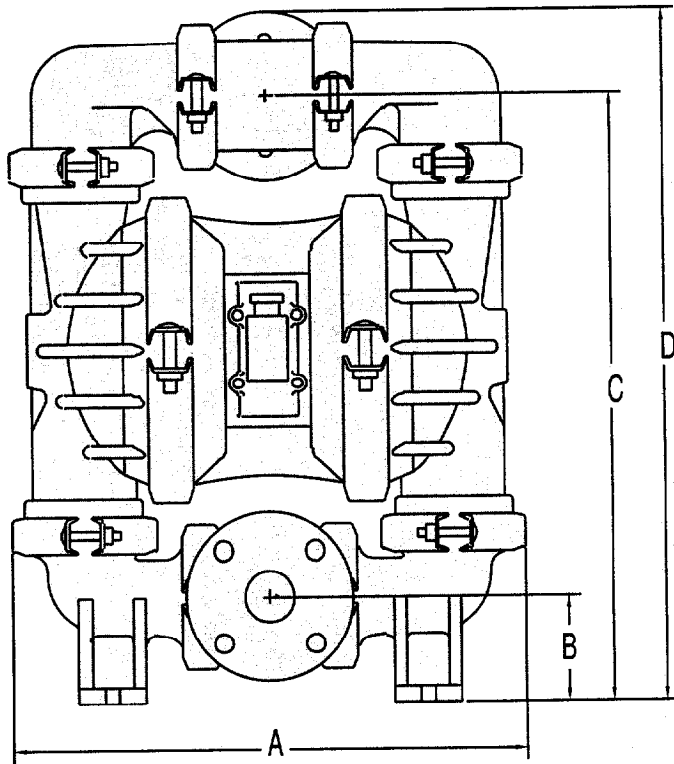

ANSI PIPE FLANGE
150 POUND CLASS
1 1/2" I.D.

| DIMENSIONS - M4 (PLASTIC) | | |
|---------------------------|-----------------|-------------|
| ITEM | STANDARD (inch) | METRIC (mm) |
| A | 15 1/2 | 393.7 |
| B | 3 1/8 | 79.4 |
| C | 18 1/4 | 463.6 |
| D | 20 3/4 | 527.1 |
| E | 12 | 304.8 |
| F | 4 3/4 | 120.7 |
| G | 10 19/32 | 269.1 |
| H | 11 3/16 | 284.2 |
| J | 11 5/16 | 287.4 |
| K | 9 11/32 | 237.3 |
| L | 7 1/8 | 181.0 |
| M | 8 1/16 | 204.8 |
| N | 15/32 | 11.9 |
| | ANSI (inch) | DIN (mm) |
| P | 1 15/16 RAD. | 55.2 RAD. |
| R | 2 1/2 RAD. | 75.2 RAD. |
| S | 9/16 DIA. | 18.0 DIA. |

SECTION 2A

PUMP PERFORMANCE CURVES

MODEL M4 METAL (Rubber/TPE-Fitted)

Height 16 $\frac{7}{8}$ "
 Width 14 $\frac{17}{32}$ "
 Depth 11 $\frac{5}{16}$ "
 Ship Weight Aluminum 37 lbs.
 Stainless Steel 52 lbs.
 Cast Iron 56 lbs.
 Hastelloy 58 lbs.
 Air Inlet $\frac{3}{8}$ " NPT
 Inlet 1 $\frac{1}{2}$ " NPT
 Outlet 1 $\frac{1}{4}$ " NPT
 Suction Lift **Rubber 21' Dry**
 27' Wet
 TPE 17' Dry
 25' Wet
 Displacement per Stroke203 gal.¹
 Max. Size Solids $\frac{3}{16}$ " Dia.

Example: To pump 30 gpm against a discharge pressure head of 40 psig requires 58 psig and 27 scfm air consumption. (See dot on chart.)

¹Displacement per stroke was calculated at 70 psig air inlet pressure against a 30 psig head pressure.

Caution: Do not exceed 125 psig air supply pressure. (50 psi on UL models.)

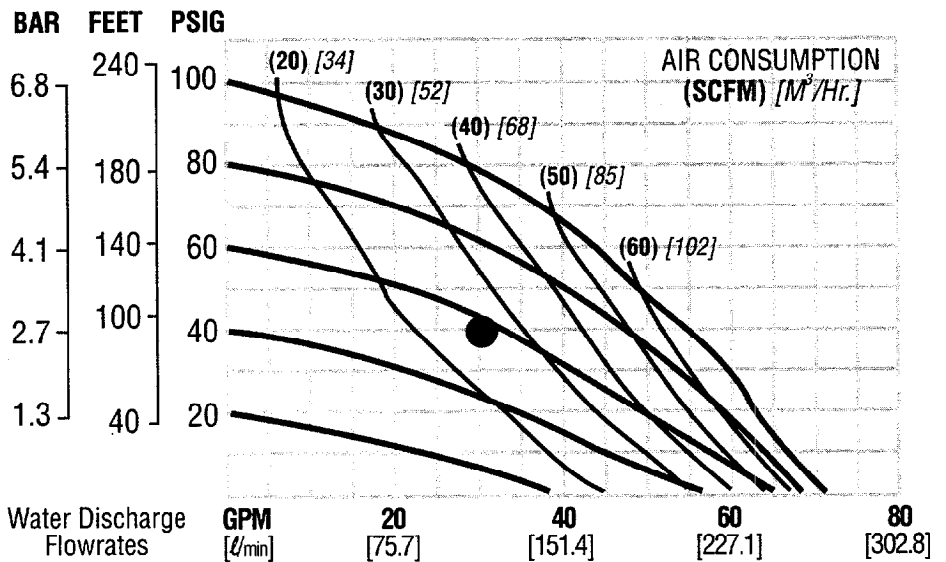

Volumes indicated on chart were determined by actually pumping water in calibrated tanks.

SECTION 2B

MODEL M4 METAL (Teflon®-Fitted)

Height 16 $\frac{7}{8}$ "
 Width 14 $\frac{17}{32}$ "
 Depth 11 $\frac{5}{16}$ "
 Ship Weight Aluminum 37 lbs.
 Stainless Steel 52 lbs.
 Cast Iron 56 lbs.
 Hastelloy 58 lbs.
 Air Inlet $\frac{3}{8}$ " NPT
 Inlet 1 $\frac{1}{2}$ " NPT
 Outlet 1 $\frac{1}{4}$ " NPT
 Suction Lift 7' Dry
 25' Wet
 Displacement per Stroke119 gal.¹
 Max. Size Solids $\frac{3}{16}$ " Dia.

Example: To pump 30 gpm against a discharge pressure head of 40 psig requires 63 psig and 49 scfm air consumption. (See dot on chart.)

¹Displacement per stroke was calculated at 70 psig air inlet pressure against a 30 psig head pressure.

Caution: Do not exceed 125 psig air supply pressure. (50 psi on UL models.)

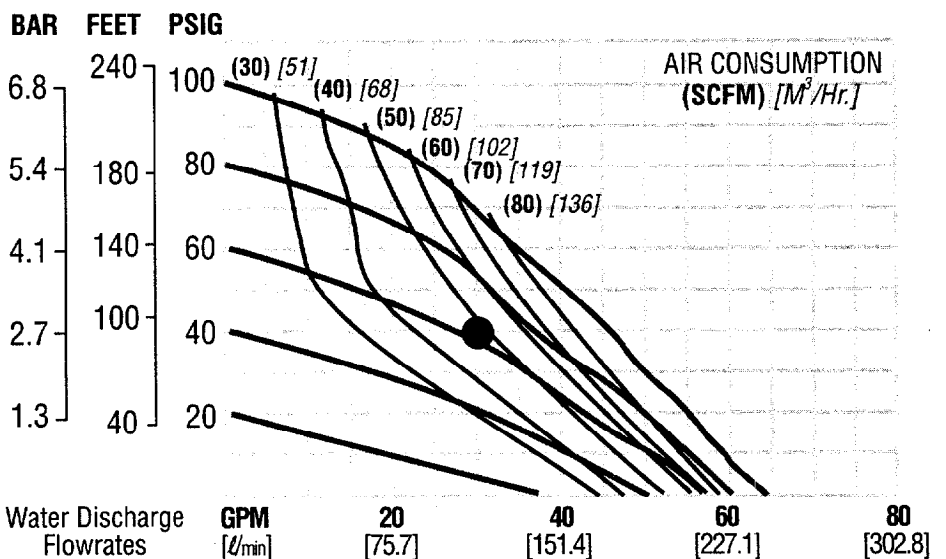

Volumes indicated on chart were determined by actually pumping water in calibrated tanks.

SECTION 2C

PUMP PERFORMANCE CURVES

MODEL M4 CHAMP (Rubber/TPE-Fitted)

Height.....20¾"
 Width.....15½"
 Depth.....11¾"
 Ship WeightPolypropylene 39 lbs.
 PVDF 49 lbs.
 Teflon® 52 lbs.
 Air Inlet¾" NPT
 Inlet.....1½" Fl.
 Outlet1½" Fl.
 Suction Lift.....**Rubber 12' Dry**
 25' Wet
 TPE 13' Dry
 25' Wet
 Displacement per Stroke291 gal.¹
 Max. Size Solids¾" Dia.

Example: To pump 30 gpm against a discharge pressure head of 40 psig requires 51 psig and 24 scfm air consumption. (See dot on chart.)

¹Displacement per stroke was calculated at 70 psig air inlet pressure against a 30 psig head pressure.

Caution: Do not exceed 125 psig air supply pressure. (50 psi on UL models.)

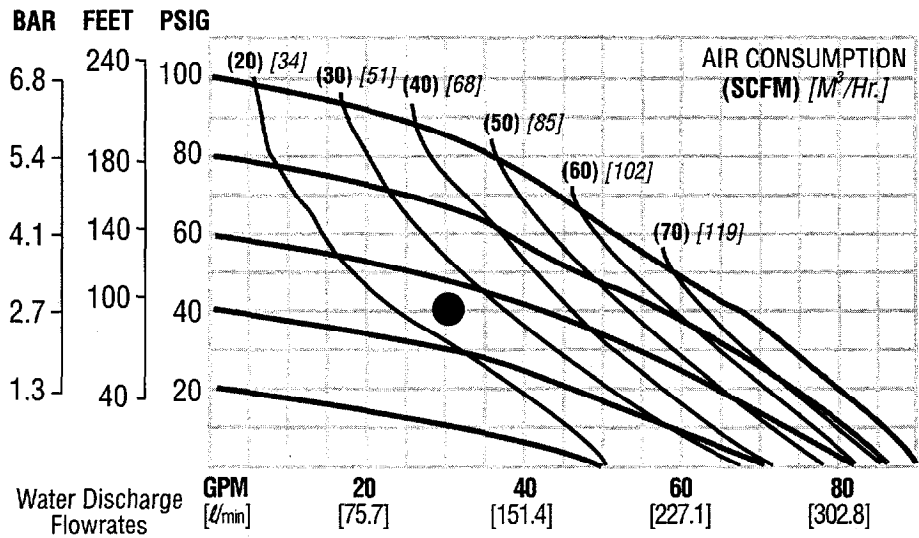

Volumes indicated on chart were determined by actually pumping water in calibrated tanks.

SECTION 2D

MODEL M4 CHAMP (Teflon®-Fitted)

Height.....20¾"
 Width.....15½"
 Depth.....11¾"
 Ship WeightPolypropylene 39 lbs.
 PVDF 49 lbs.
 Teflon® 52 lbs.
 Air Inlet¾" NPT
 Inlet.....1½" Fl.
 Outlet1½" Fl.
 Suction Lift.....7' Dry
 25' Wet
 Displacement per Stroke126 gal.¹
 Max. Size Solids¾" Dia.

Example: To pump 30 gpm against a discharge pressure head of 40 psig requires 78 psig and 58 scfm air consumption. (See dot on chart.)

¹Displacement per stroke was calculated at 70 psig air inlet pressure against a 30 psig head pressure.

Caution: Do not exceed 125 psig air supply pressure. (50 psi on UL models.)

Note: M4 Ultrapure pumps have a dry suction lift of 6'.

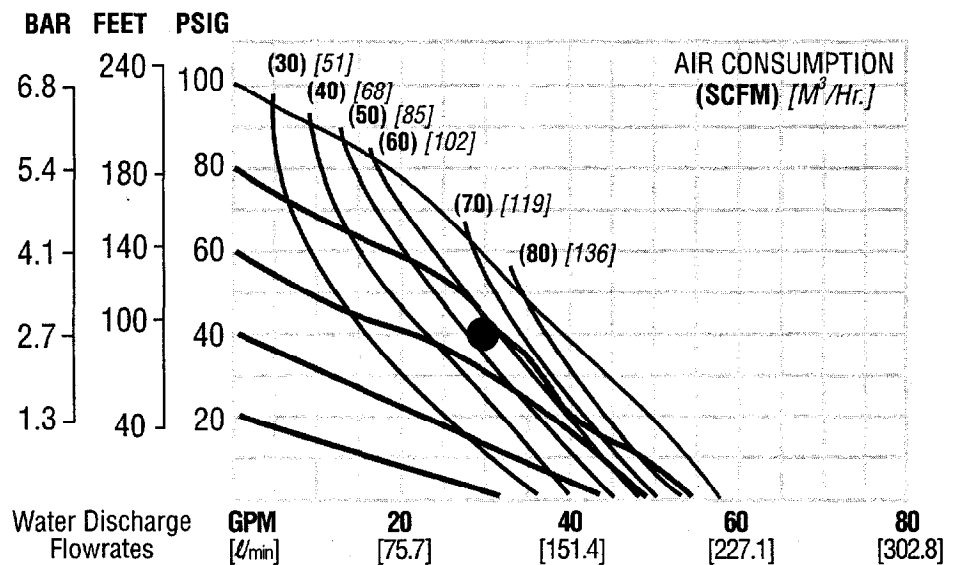

Volumes indicated on chart were determined by actually pumping water in calibrated tanks.

SECTION 3

INSTALLATION

The Model M4 has a 1½" inlet and 1¼" outlet and is designed for flows to 73 gpm. The **M4 Champ** pump is manufactured with wetted parts of pure, unpigmented PVDF, Teflon®, or polypropylene. The **M4 Metal** pump is manufactured with wetted parts of aluminum, cast iron, stainless steel or Hastelloy. The center section of the **M4** is constructed of glass-filled polypropylene. A variety of diaphragms, valve balls, and O-rings are available to satisfy temperature, chemical compatibility, abrasion and flex concerns.

The suction pipe size should be at least 1½" diameter or larger if highly viscous material is being pumped. The suction hose must be non-collapsible, reinforced type as the M4 is capable of pulling a high vacuum. Discharge piping should be at least 1½"; larger diameter can be used to reduce friction losses. It is critical that all fittings and connections are airtight or a reduction or loss of pump suction capability will result.

For M4 Champ models, Wilden offers 150 lb. ANSI and DIN flanges. The following details should be noted when mating these to pipe works:

- A 60–80 shore gasket that covers the entire flange face should be used.
- The gasket should be between .075" and .175" thickness.
- Mating flanges with flat as opposed to raised surfaces should be used for proper mechanical sealing.
- The flanges should be tightened to a minimum of 5 ft.-lbs. (6.8 m-N) but no more than 10 ft.-lbs. (13.5 m-N).

For M4 Champ models, a non-raised surfaced-flange adapter should be utilized when mating to the pump's inlet and discharge manifolds for proper sealing.

The M4 can be used in submersible applications only when both wetted and non-wetted portions are compatible with the

material being pumped. If the pump is to be used in a submersible application, a hose should be attached to the pump's air exhaust and the exhaust air piped above the liquid level.

If the pump is to be used in a self-priming application, be sure that all connections are airtight and that the suction lift is within the pump's ability. Note: Materials of construction and elastomer material have an effect on suction lift parameters. See performance curve data..

Pumps in service with a positive suction head are most efficient when inlet pressure is limited to 7–10 psig. Premature diaphragm failure may occur if positive suction is 11 psig and higher.

THE MODEL M4 WILL PASS 3/16" SOLIDS. WHENEVER THE POSSIBILITY EXISTS THAT LARGER SOLID OBJECTS MAY BE SUCKED INTO THE PUMP, A STRAINER SHOULD BE USED ON THE SUCTION LINE.

CAUTION: DO NOT EXCEED 125 PSIG AIR SUPPLY PRESSURE. (50 PSI ON UL MODELS.)

ALUMINUM AND CAST IRON PUMPS ARE FUNCTION TESTED WITH WATER AND SODIUM SILICATE. PUMPS SHOULD BE THOROUGHLY FLUSHED WITH WATER BEFORE INSTALLING INTO PROCESS LINES. FDA AND USDA APPROVED PUMPS SHOULD BE CLEANED AND/OR SANITIZED BEFORE BEING USED ON EDIBLE PRODUCTS.

BLOW OUT AIR LINE FOR 10 TO 20 SECONDS BEFORE ATTACHING TO PUMP TO MAKE SURE ALL PIPE LINE DEBRIS IS CLEAR. ALWAYS USE AN IN-LINE FILTER.

SECTION 4

SUGGESTED OPERATION AND MAINTENANCE INSTRUCTIONS

INSTALLATION: Months of careful planning, study, and selection efforts can result in unsatisfactory pump performance if installation details are left to chance.

Premature failure and long term dissatisfaction can be avoided if reasonable care is exercised throughout the installation process.

LOCATION: Noise, safety, and other logistical factors usually dictate that "utility" equipment be situated away from the production floor. Multiple installations with conflicting requirements can result in congestion of utility areas, leaving few choices for siting of additional pumps.

Within the framework of these and other existing conditions, every pump should be located in such a way that four key factors are balanced against each other to maximum advantage.

1. **ACCESS:** First of all, the location should be accessible. If it's easy to reach the pump, maintenance personnel will have

an easier time carrying out routine inspections and adjustments. Should major repairs become necessary, ease of access can play a key role in speeding the repair process and reducing total downtime.

2. **AIR SUPPLY:** Every pump location should have an air line large enough to supply the volume of air necessary to achieve the desired pumping rate (see pump performance chart). Use air pressure up to a maximum of 125 psi depending upon pumping requirements.

For best results, the pumps should use an air filter, regulator, and lubricator system. The use of an air filter before the pump will ensure that the majority of any pipeline contaminants will be eliminated. The use of a lubricant, suitable for the application, helps perform a number of functions. Lubricants reduce friction to minimize required shifting forces and reduce wear. Lubricants provide a protective coating against some forms of corrosion and contaminants. **Wilden suggests an oil with arctic characteristics (ISO 15-5Wt.)**

This oil is chemically compatible with the center block O-rings and has a low pour point to guard against problems associated with low temperatures. The amount of lubrication required is directly related to the amount of oil introduced from the factory air system. We therefore suggest that the lowest setting on the lubricator be utilized and then increased as necessary.

Pump discharge rate can be controlled by limiting the volume and/or pressure of the air supply to the pump. The use of a needle valve installed at the air inlet to the pump is suggested for this purpose. Pump discharge rate can also be controlled by throttling the pump discharge by installing a valve in the discharge line of the pump when the need to control the pump from a remote location exists. When the pump discharge pressure equals or exceeds the air supply pressure, the pump will stall out; no bypass or pressure relief valve is needed, and pump damage will not occur. When operation is controlled by a solenoid valve in the air line, a three-way valve should be used. Pumping volume can be set by counting the number of strokes per minute.

A muffler installed on the pump's air exhaust will give quiet exhaust. Sound levels are reduced below OSHA specifications using a Wilden muffler.

3. ELEVATION: Selecting a site that is well within the pump's suction lift capability will assure that loss-of-prime troubles will be eliminated. In addition, pump efficiency can be adversely affected if proper attention is not given to elevation (see pump performance chart).

4. PIPING: Final determination of the pump site should not be made until the piping problems of each possible location have been evaluated. The impact of current and future installations should be considered ahead of time to make sure that inadvertent restrictions are not created for any remaining sites.

The best choice possible will be a site involving the shortest and the straightest hook-up of suction and discharge

piping. Unnecessary elbows, bends, and fittings should be avoided. Pipe sizes should be selected so as to keep friction losses within practical limits. All piping should be supported independently of the pump. In addition, it should line up without placing stress on the pump fittings.

Expansion joints can be installed to aid in absorbing the forces created by the natural reciprocating action of the pump. If the pump is to be bolted down to a solid foundation, a mounting pad placed between the pump and foundation will assist in minimizing pump vibration. Flexible connections between the pump and rigid piping will also assist in minimizing pump vibration. If quick-closing valves are installed at any point in the discharge system, or if pulsation within a system becomes a problem, a surge suppressor should be installed to protect the pump, piping and gauges from surges and water hammer.

When pumps are installed in applications involving flooded suction or suction head pressures, a gate valve should be installed in the suction line to permit closing of the line for pump service.

INSPECTIONS: Periodic inspections have been found to offer the best means for preventing unscheduled pump downtime.

Individuals responsible for checking and maintaining lubrication levels in the pumps should also check for any abnormal noise or leakage. Personnel familiar with the pumps' construction and service should be informed of any abnormalities that are detected.

RECORDS: When service is required, a record should be made of all necessary repairs and replacements. Over a period of time, such records can become a valuable tool for predicting and preventing future maintenance problems and unscheduled downtime. In addition, accurate records make it possible to identify pumps that are poorly suited to their applications.

SECTION 5

TROUBLESHOOTING

Pump will not run or runs slowly.

1. Check air inlet screen and air filter for debris.
2. Check for sticking air valve, flush air valve in solvent.
3. Check for worn out air valve. If piston face in air valve is shiny instead of dull, air valve is probably worn beyond working tolerances and must be replaced.
4. Check center block O-rings. If worn excessively, they will not seal and air will simply flow through pump and out air exhaust. Use only Wilden O-rings as they are of special construction and ISO 15-5 wt oil with arctic characteristics.
5. Check for rotating piston in air valve.
6. Check type of lubricant being used. A higher viscosity oil than suggested may cause the piston to stick or run erratically. Wilden suggests the use of a hydraulic oil with arctic characteristics (ISO 15-5 wt).

Pump runs but little or no product flows.

1. Check for pump cavitation; slow pump speed down to match thickness of material being pumped.

2. Check for sticking ball checks. If material being pumped is not compatible with pump elastomers, swelling may occur. Replace ball checks and O-rings with proper elastomers.
3. Check to make sure all suction connections are air tight, especially clamp bands around intake balls.

Pump air valve freezes.

Check for excessive moisture in compressed air. Either install dryer or hot air generator for compressed air.

Air bubbles in pump discharge.

1. Check for ruptured diaphragm.
2. Check tightness of clamp bands, especially at intake manifold.

Product comes out air exhaust.

1. Check for diaphragm rupture.
2. Check tightness of piston plates to shaft.

SECTION 6A

MODEL M4 METAL

DIRECTIONS FOR DISASSEMBLY/REASSEMBLY

CAUTION: Before any maintenance or repair is attempted, the compressed air line to the pump should be disconnected and all air pressure allowed to bleed from pump. Disconnect all intake, discharge, and air lines. Drain the pump by turning it upside down and allowing any fluid to flow into a suitable container.

The Wilden M4 has a 1½" inlet and 1¼" outlet and is designed for flows up to 73 GPM. Its air distribution system is based on design simplicity and proven efficiency. The model M4 is available in aluminum, cast iron, 316 stainless steel, or Hastelloy wetted parts. The aluminum model features die-cast water chambers, which allow for streamlined contours, while reducing friction of fluid flow. For highly corrosive applications, polypropylene, Teflon® PFA, and PVDF models are available.

NOTE: Before starting disassembly, mark a line from each liquid chamber to its corresponding air chamber. This line will assist in proper alignment during reassembly.

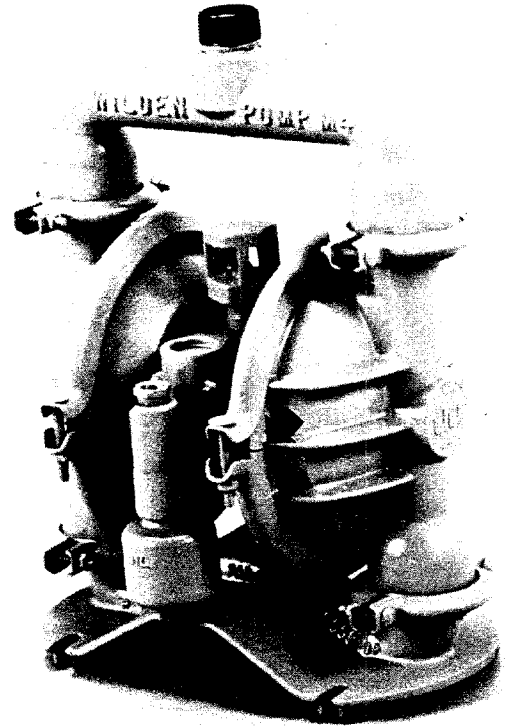

DISASSEMBLY: Step 1.

NOTE: Model used for these instructions incorporates rubber diaphragms, balls, and seats. Models with Teflon® diaphragms, balls and seats are the same except where noted.

Start by removing the two clamp bands that fasten the discharge manifold to the main body of the pump. (Figures 1A and 1B.)

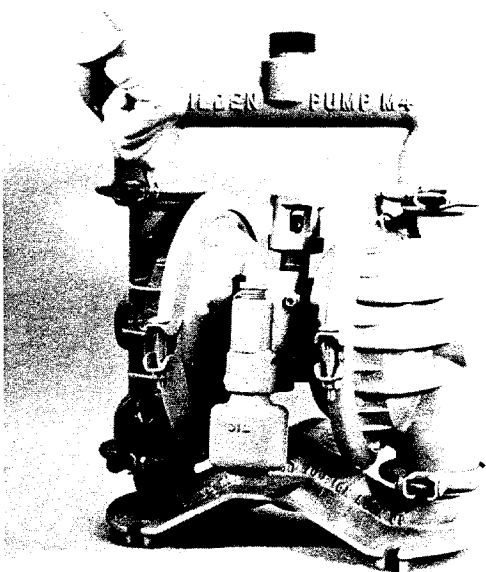

Figure 1A

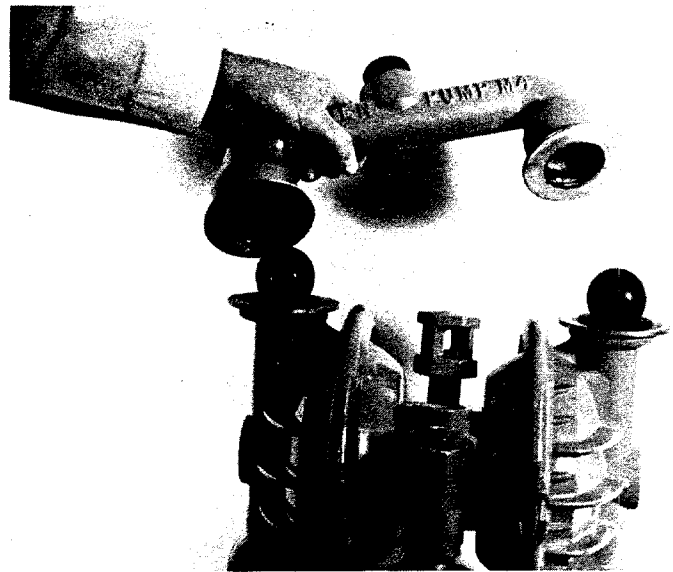

Figure 1B

Step 2.

Remove the two clamp bands that hold the inlet manifold to the main body of the pump. Lift the main body of the pump from the inlet manifold and set it to one side. The inlet ball valves, and seats are now available for examination. (See *Figure 2A.*) Next, remove large clamp bands which attach water chamber to the center section of the pump. (See *Figure 2B.*)

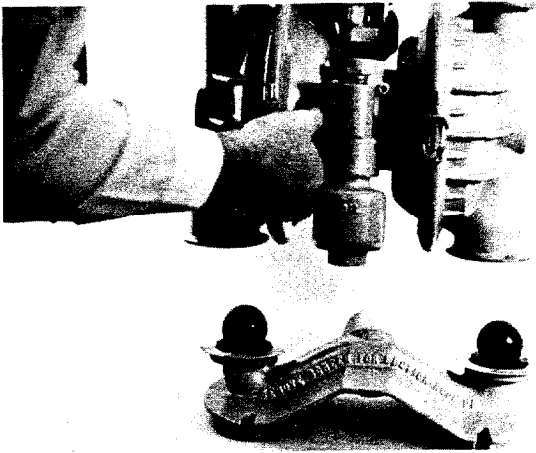

Figure 2A

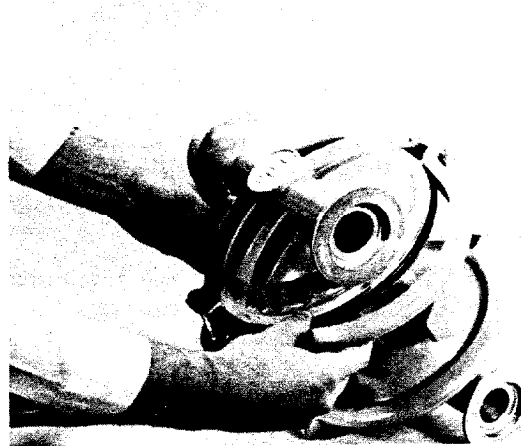

Figure 2B

Remove only one liquid chamber from the center section. This will expose the diaphragm and its piston plate. (See *Figure 2C.*) The diaphragm and the piston plate can be removed by unscrewing them from the connecting shaft with an adjustable wrench. The opposite diaphragm will be held tight by the opposite liquid chamber. (See *Figure 2D.*)

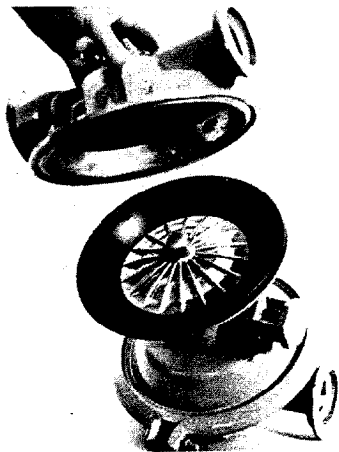

Figure 2C

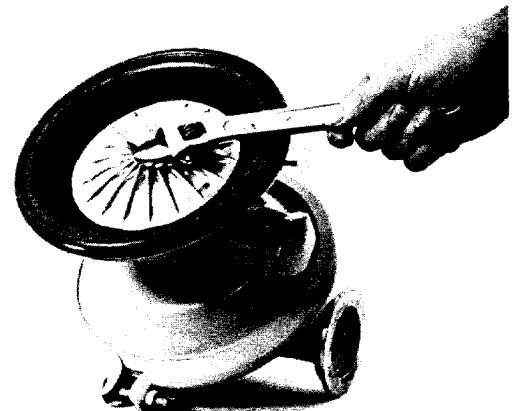

Figure 2D

Now remove the opposite liquid chamber. The second diaphragm is now available for inspection and cleaning. (See *Figure 2E.*) If the second diaphragm is to be removed, **it is important not to score or mark the chrome-plated shaft.** A vise with wood blocks is suggested as a method of securing the shaft while removing the second diaphragm.

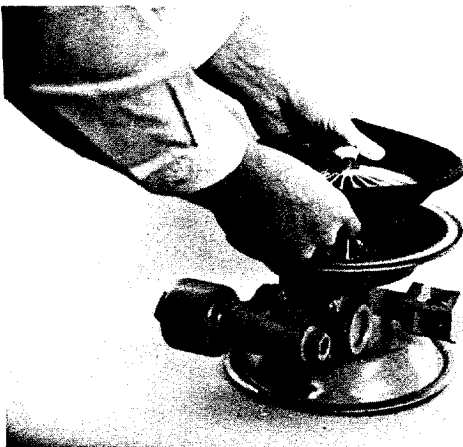

Figure 2E

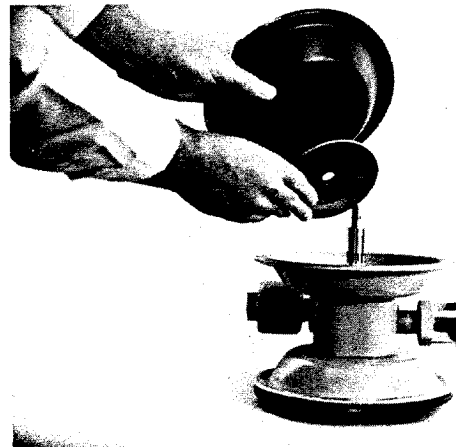
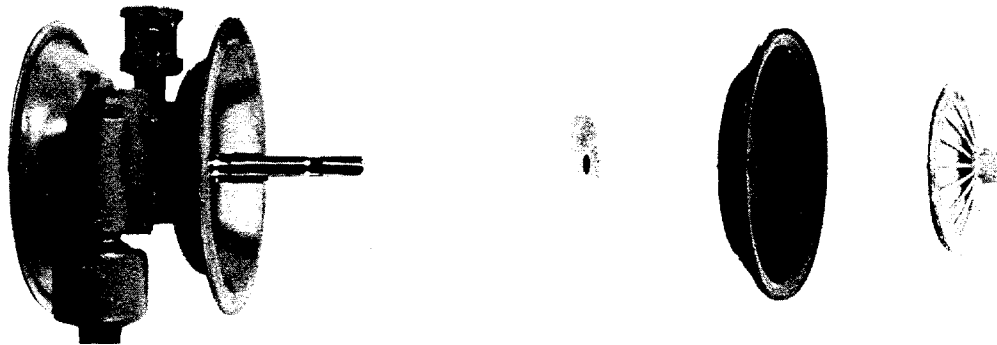

Figure 2F

Upon removing the diaphragms, the inner piston is now exposed and available for inspection. (See *Figure 2F.*)

ASSEMBLY



Exploded View Figure 3A

Step 1 (Rubber/TPE Diaphragms)

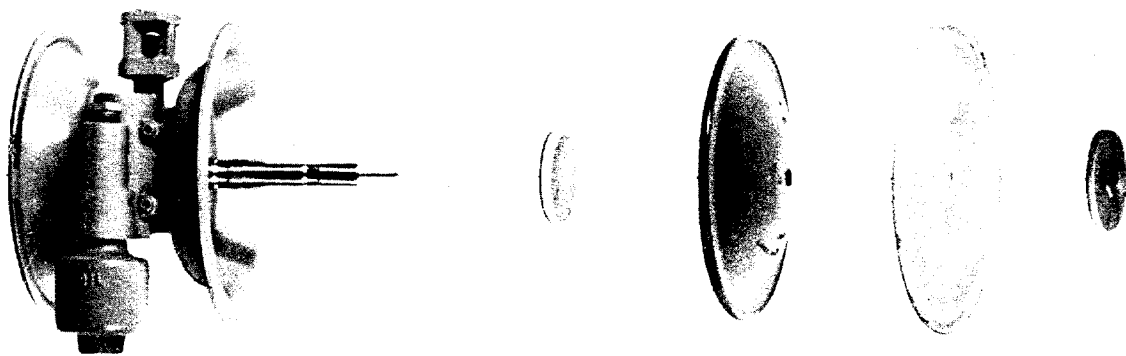

Exploded View Figure 3B

(Teflon® Diaphragms)



Figure 4A

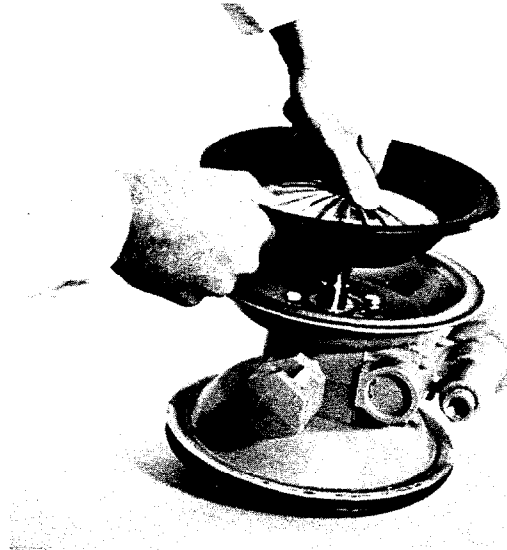

Figure 4B

Step 2.

To install shaft, push shaft firmly through the bushing in the center block. Be sure to lubricate bushing with ISO Grade 15-5 wt. oil so that shaft may pass by the O-rings. (See Figure 4A.) Next, install outer piston to diaphragm assembly and tighten to the required torque specification*. (See Figure 4B.) Once opposite water chamber is attached to center section, place center section on its side and push second diaphragm assembly toward the lip of the air chamber until the outer bead of the diaphragm rests within this groove. Tighten outer piston per the torque specification*. (See Figure 4C.) The outer clamp band can now be installed and tightened per the torque specification*. The center section can now be placed over the inlet manifold. Be sure to observe the previously made alignment marks. (See Figures 4D and 4E.) **Note: When installing Teflon® diaphragms, it is important to tighten outer pistons simultaneously (turning in opposite direction) to ensure a tight fit.**

*Refer to Section 8 for torque specifications.

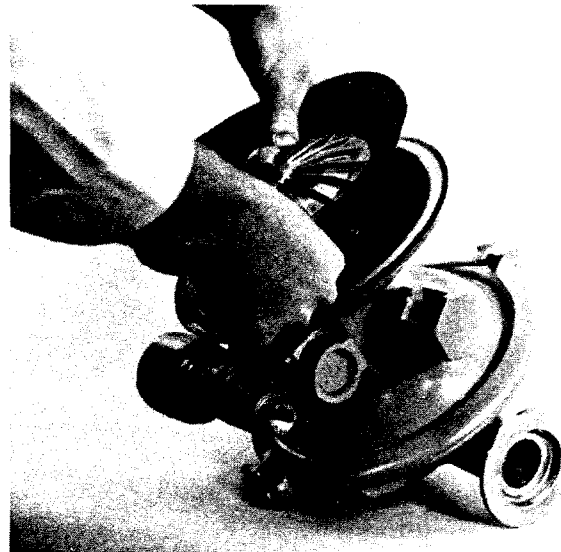

Figure 4C

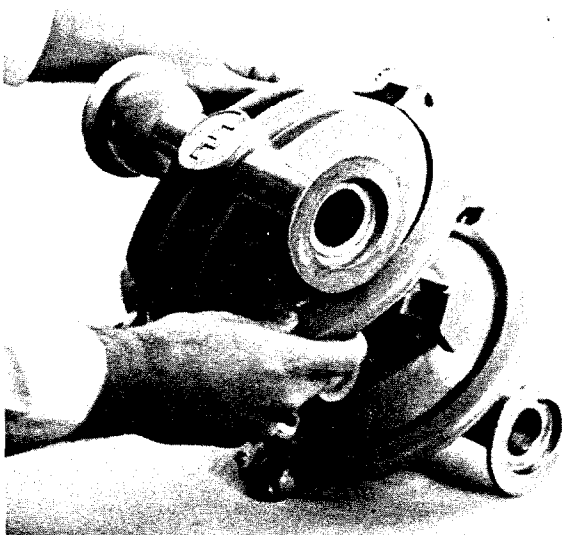

Figure 4D

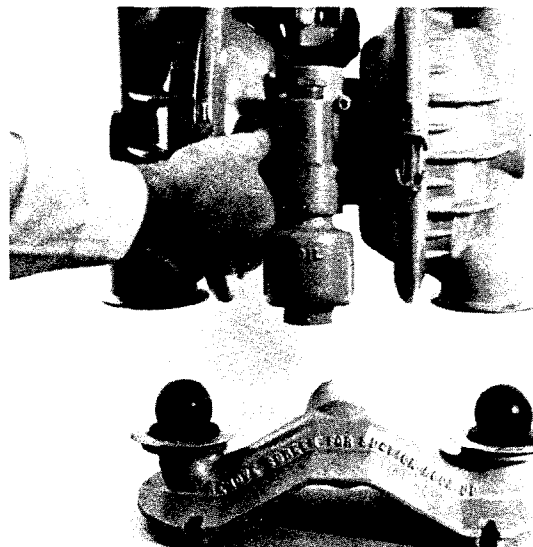

Figure 4E

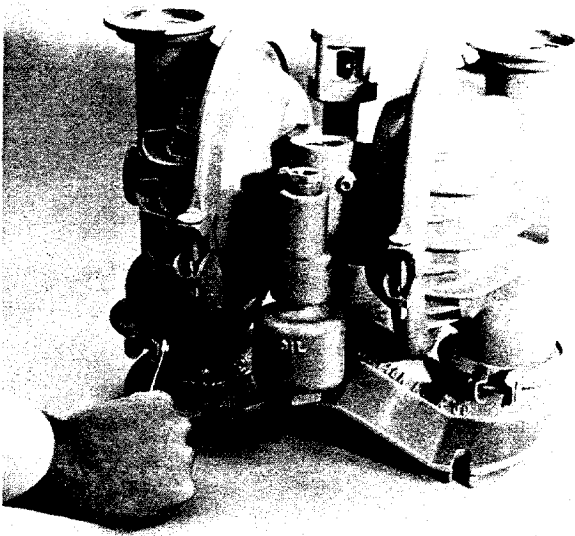

Figure 4F

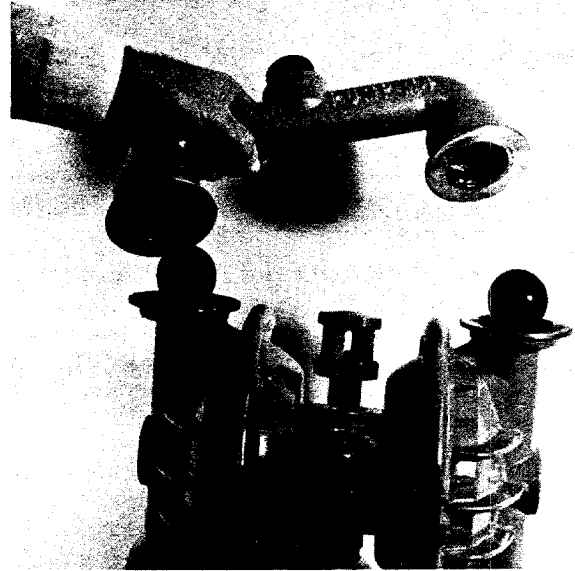

Figure 4G

Next, securely tighten small clamp bands around inlet manifold and water chambers. (See *Figure 4F*.) Finally, place discharge manifold over assembled center section (see *Figure 4G*) and secure small clamp bands. Tighten small clamp bands around inlet and discharge manifolds per the torque specification*.

*Refer to Section 8 for torque specifications.

Notes

SECTION 6B

MODEL M4 CHAMP (PLASTIC)

DIRECTIONS FOR DISASSEMBLY/REASSEMBLY

CAUTION: Before any maintenance or repair is attempted, the compressed air line to the pump should be disconnected and all air pressure allowed to bleed from pump. Disconnect all intake, discharge, and air lines. Drain the pump by turning it upside down and allowing any fluid to flow into a suitable container.

The Wilden "Champ" is a Wilden model M4 pump (1.5 inch) with all wetted parts of injection molded polypropylene, PVDF and Teflon® PFA material. Performance and operation of the "Champ" are essentially the same as other Wilden model M4 pumps of metal construction subject to temperature and chemical compatibility of the material being pumped with polypropylene, PVDF and Teflon® PFA.

NOTE: Before starting disassembly, mark a line from each liquid chamber to its corresponding air chamber. This line will assist in proper alignment during reassembly.

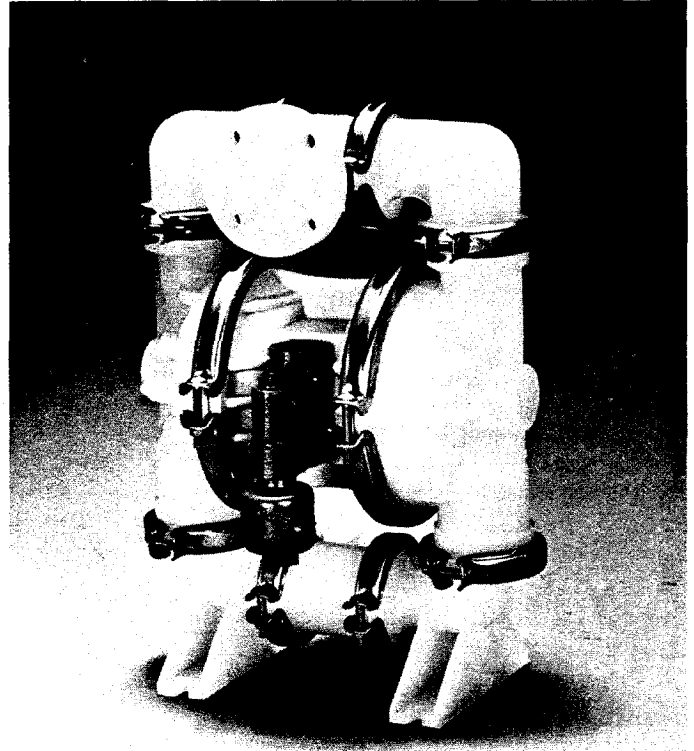

DISASSEMBLY:

Step 1.

Start by removing the two clamp bands that fasten the discharge manifold to the main body of the pump.

NOTE: Model used for these instructions incorporates rubber diaphragms, balls, and O-rings. Models with Teflon® diaphragms, balls and seats are the same except where noted.

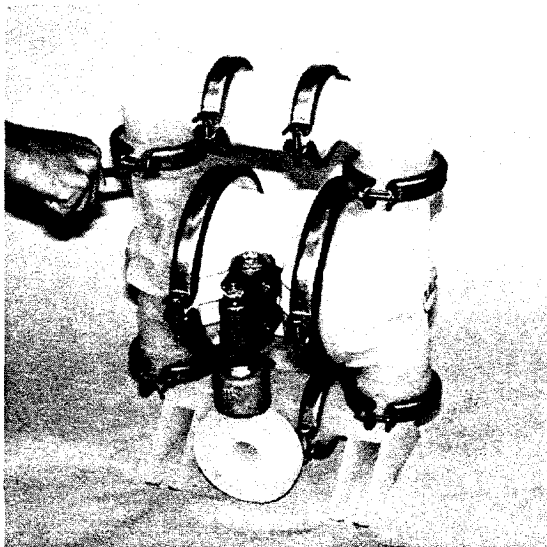

Figure 1A

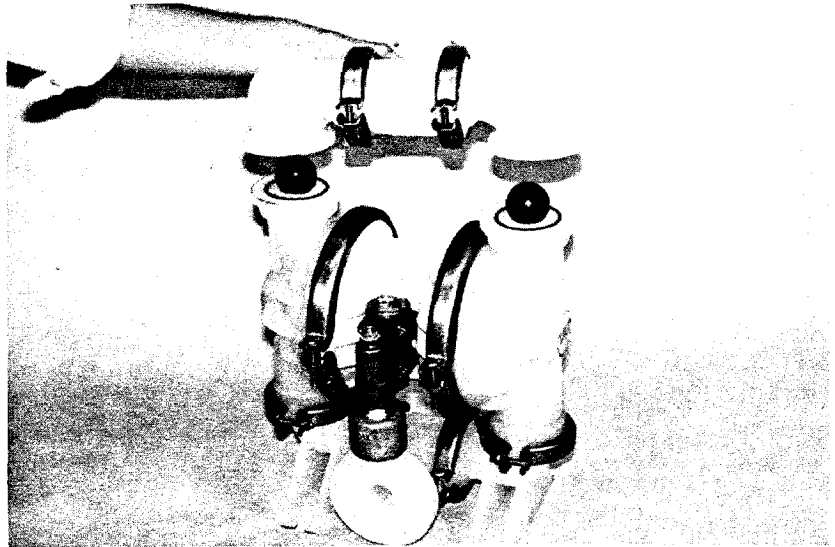

Figure 1B

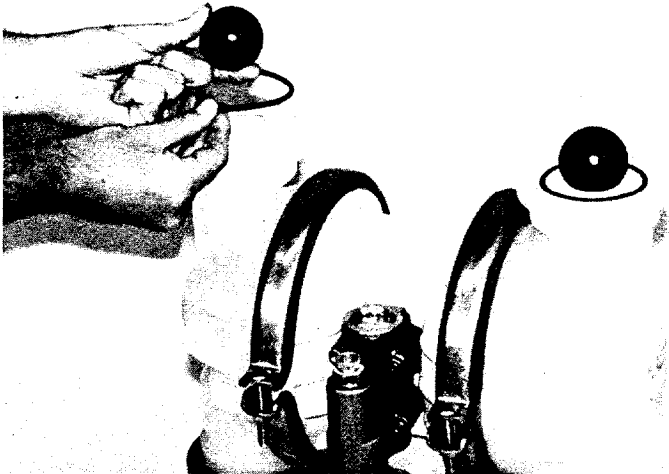

Figure 2A

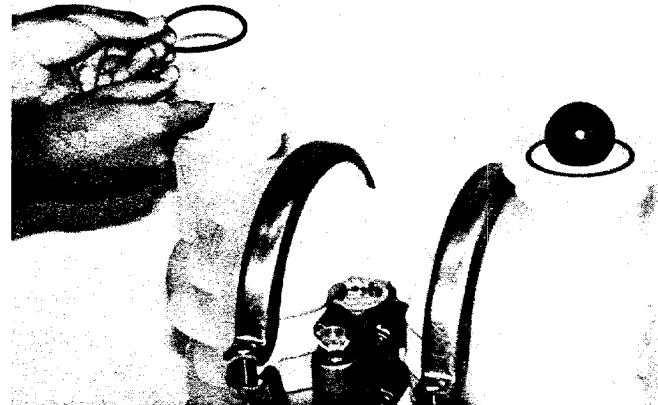

Figure 2B

Step 2.

The valve ball, round O-ring and the seat are now exposed for inspection. If the O-ring is flattened or out-of-round, it must be replaced. Valve ball and seat should be inspected for damage or excessive wear.

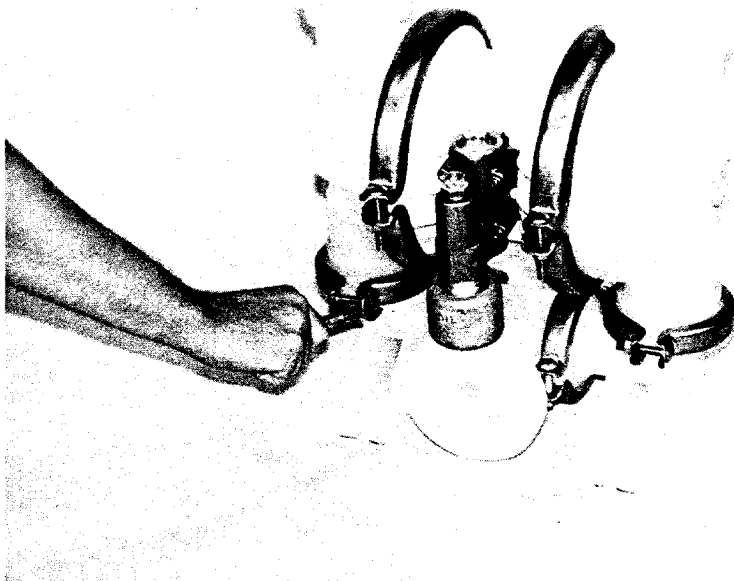

Figure 3A

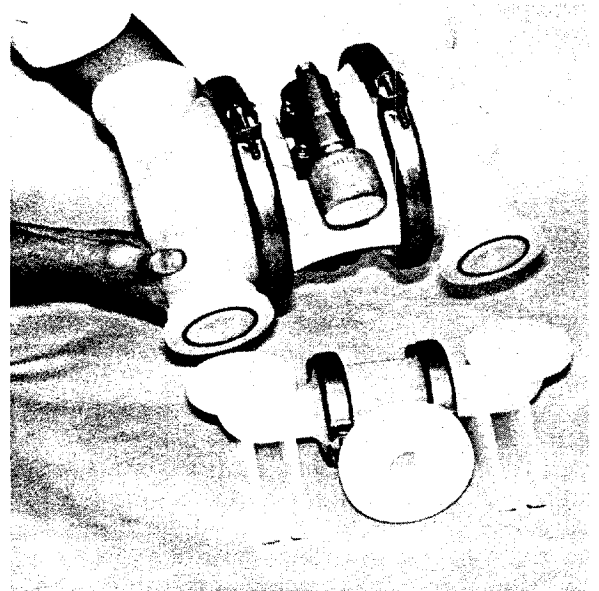

Figure 3B

Step 3.

Remove the two clamp bands that hold the inlet manifold to the main body of the pump. Lift the main body of the pump from the inlet manifold and set it to one side. The inlet ball valves, seats and O-rings are now available for examination.

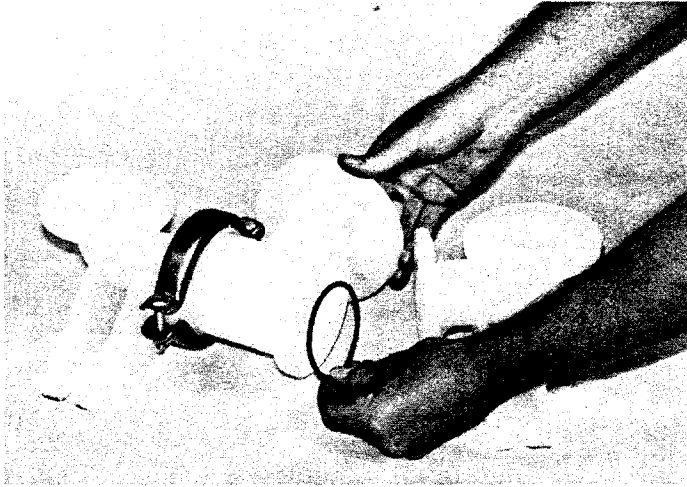

Figure 4A

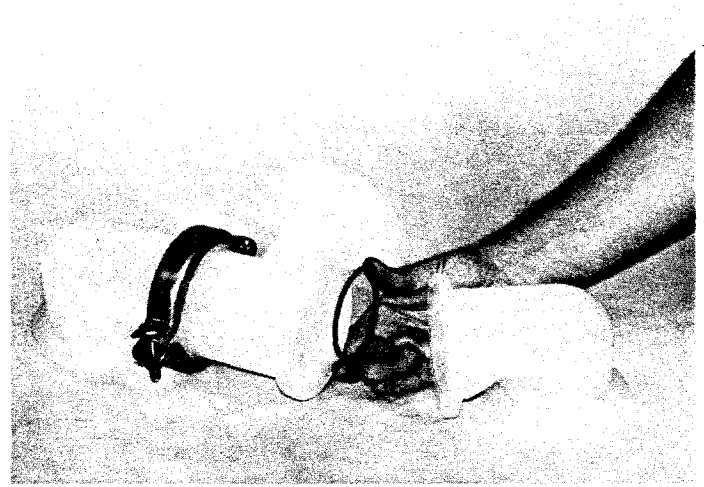

Figure 4B

Step 4.

Both inlet (Figure 4A) and discharge (Figure 4B) manifolds can now be disassembled by removing their clamp bands. Make sure the round O-rings are not damaged or swollen. These O-rings form the seal between the manifold ports and will not perform their function if damaged. **NOTE:** Manifolds do not normally need to be disassembled for maintenance.

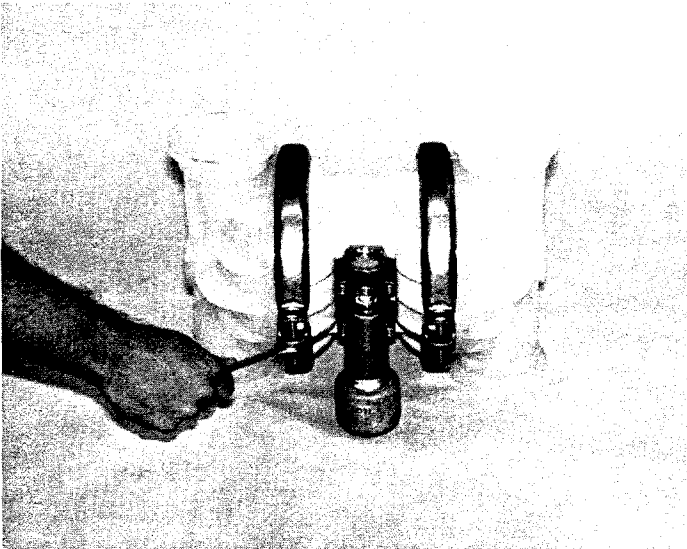

Figure 5A

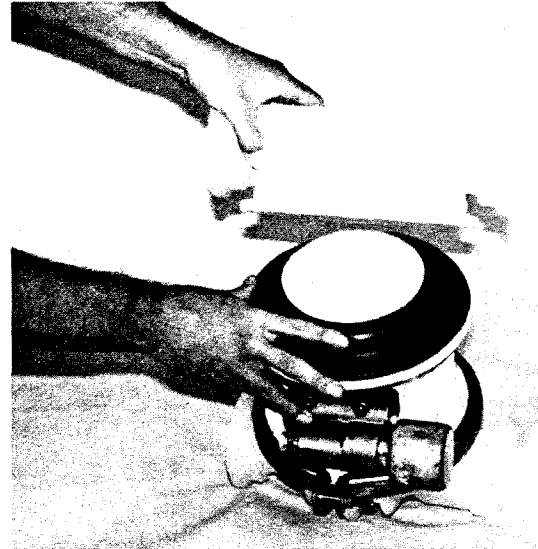

Figure 5B

Step 5.

Remove only one liquid chamber (P/N 04-5000-20) from the center section. This will expose the diaphragm and its piston plate. By grasping the outer edges of the diaphragm and turning counterclockwise, the diaphragm and piston plate can be removed by unscrewing them from the connecting shaft. The opposite diaphragm will be held tight by the opposite liquid chamber. **NOTE:** The shaft may unscrew from the opposite diaphragm. Flats are provided on the piston plate for a wrench if necessary. **It is important not to score or mark the chrome-plated shaft.** A vise with wood blocks is suggested as a method of securing the shaft while removing the second diaphragm. Now remove the opposite liquid chamber. The second diaphragm is now available for inspection and cleaning. If inspection and/or servicing of the non-wetted air section is necessary please see Section 6C.



Figure 5C

ASSEMBLY

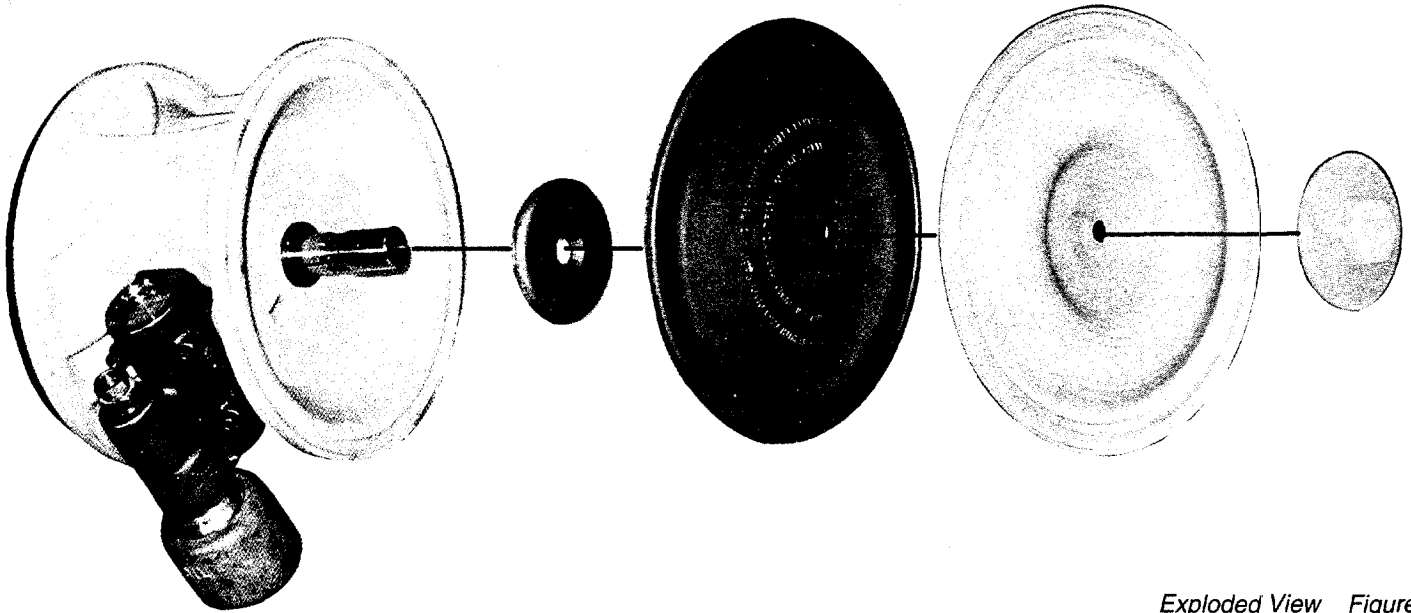

Exploded View Figure 6A

Step 1. (Teflon® Diaphragms)

First, install diaphragm and inner and outer piston plates on shaft. Observe the **“This Side Out”** marking on the convex side of the diaphragm. Hand-tighten the outer piston to the shaft only, at this time. (Figure 7A.) Insert the shaft through the bushing until the outer bead of the diaphragm just touches the circumference groove of the air chamber.

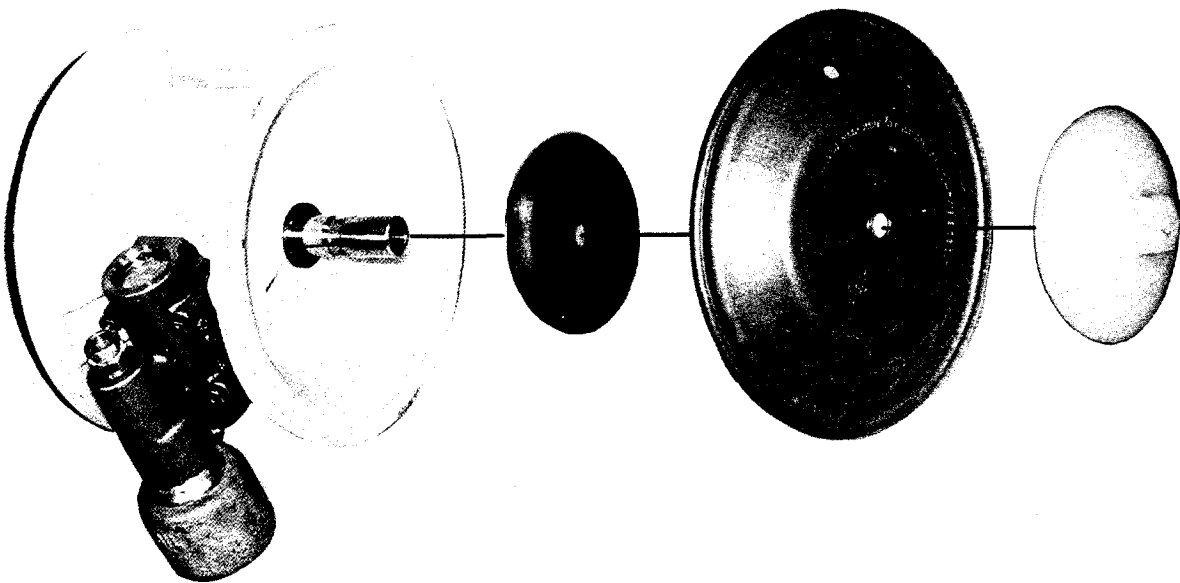

Exploded View Figure 6B

(Rubber Diaphragms)



Figure 7A



Figure 7B

Step 2.

Install the opposite diaphragm and inner and outer pistons; hand-tighten. Now tighten both diaphragm outer pistons simultaneously (turning in opposite directions) per the torque specification*. Install water chambers over the diaphragms using the alignment marks that were made during disassembly as a guide. (Direction of flow through the pump is bottom to top.) Install and tighten clamp bands per the torque specification*. (Figures 7B and 7C.)

*Refer to Section 8 for torque specifications.

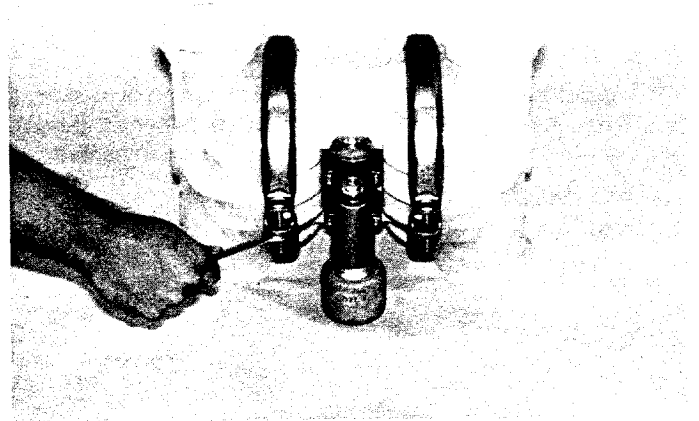

Figure 7C

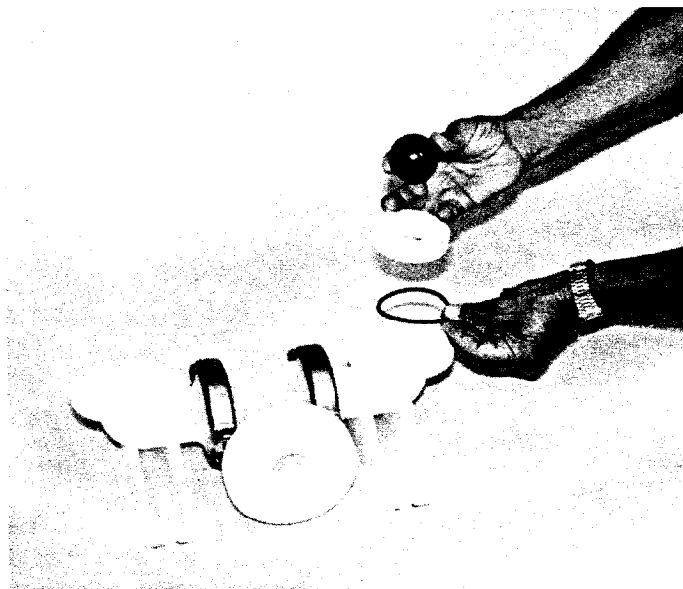

Figure 8A

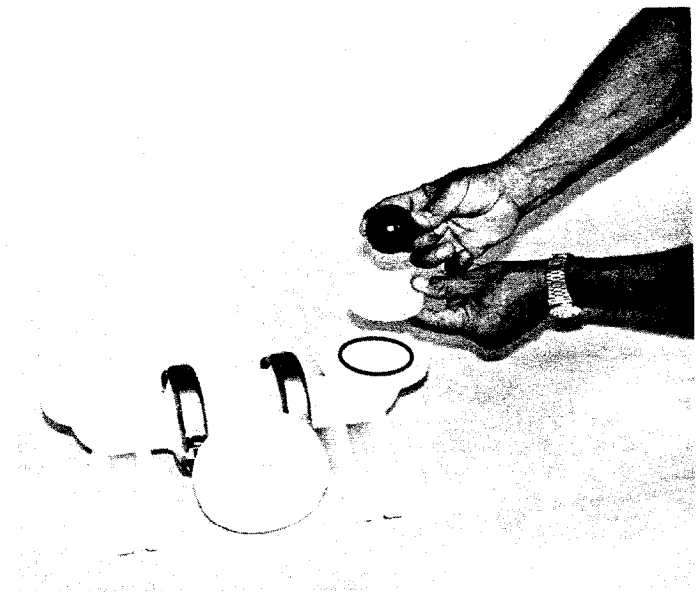

Figure 8B

Step 3.

Install inlet ball valve, O-ring and seat in sequential order as shown in Figures 8A and 8B.

Step 4 (Teflon® Elastomers only).

M4 "Champ" pumps with Teflon® elastomers require the use of a Teflon® gasket kit (P/N 08-9500-99). The Teflon® gasket material in this kit is an expanded type of Teflon® which is very strong, but soft. Its use assures a positive seal between the Teflon® diaphragm outer bead and its corresponding groove in the water chamber. This gasket material should be replaced each time the pump is disassembled.

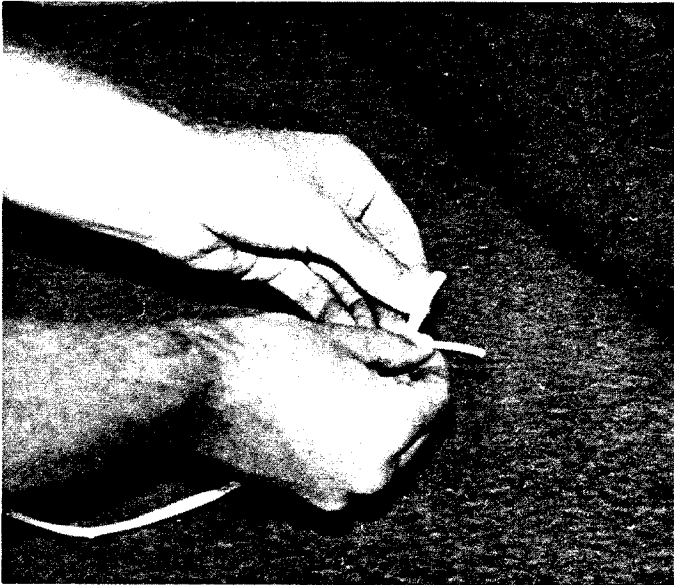

Figure 9A

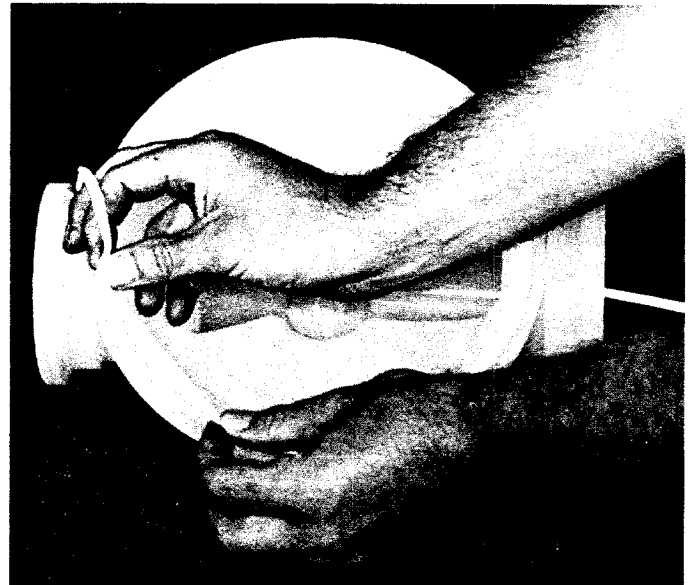

Figure 9B

Select a strip of $\frac{3}{16}$ "-wide material and carefully remove the covering from the adhesive strip (see Figure 9A). Ensure that the adhesive strip remains attached to the gasket material. Starting at any point, place the gasket strip in the center of the diaphragm bead groove on the chamber (P/N 04-5000-20) and press lightly on the gasket to ensure that adhesive holds it in place during assembly (Figure 9B). The ends of the gasket should overlap approximately $\frac{1}{8}$ -inch.

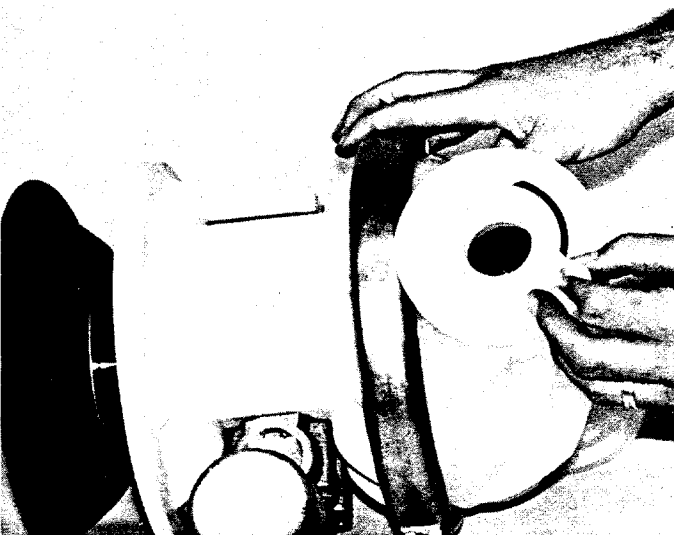

Figure 9C



Figure 9D

All PVDF pumps with Teflon® elastomers utilize gasket material around the seat area as well. If sealing is a concern, the gasket material can be used with polypropylene pumps as well. Notice that the adhesive strip for the inlet and discharge manifold is $\frac{1}{2}$ ", and that it, too, is wrapped in much the same way as in Figures 9A and 9B. Make sure that adhesive strip covers the round O-ring completely.

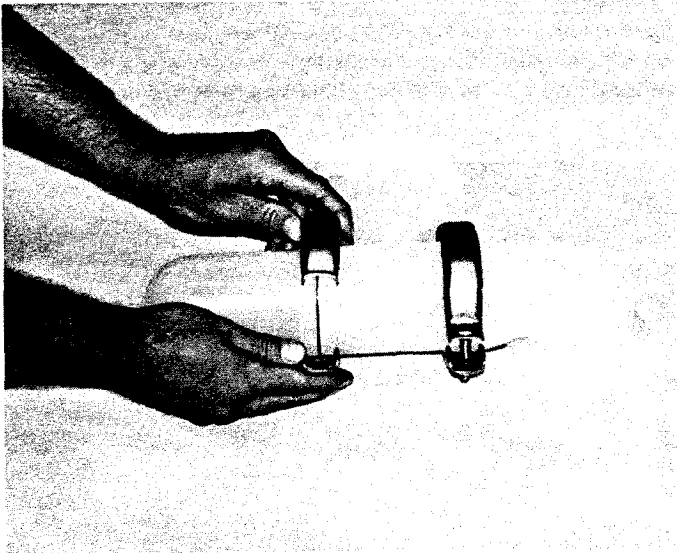

Figure 10A

Step 5.

Manifold Assembly: If the inlet and/or discharge manifold was taken apart, it should be reassembled now. The easiest way to do this is to take one half clamp band and wedge it onto the flanges of the elbow and center T-section. (See *Figure 10A*). Align the manifold parts as in *Figure 10C*, and tighten the clamps per the torque specification*. **NOTE:** On pumps equipped with Teflon® diaphragms, balls, and sealing rings, Teflon® gaskets should be used between the flanges of the manifold. (See *Step 9D*.)

*Refer to Section 8 for torque specifications.

Step 6.

Next, install the valve seat, O-ring, and valve ball on top of the liquid chamber. Tighten clamp bands per the torque specification* (Item #3).

Step 7.

Retighten all clamp bands, blow out air line for 10 to 20 seconds to make sure all pipeline debris is clear. Connect an air line to the pump and run it dry. The pump should shift evenly and good suction should be observed at the inlet.

NOTE: AIR VALVE AND CENTER SECTION DISASSEMBLY/ REASSEMBLY IS SHOWN IN SECTION 6C.

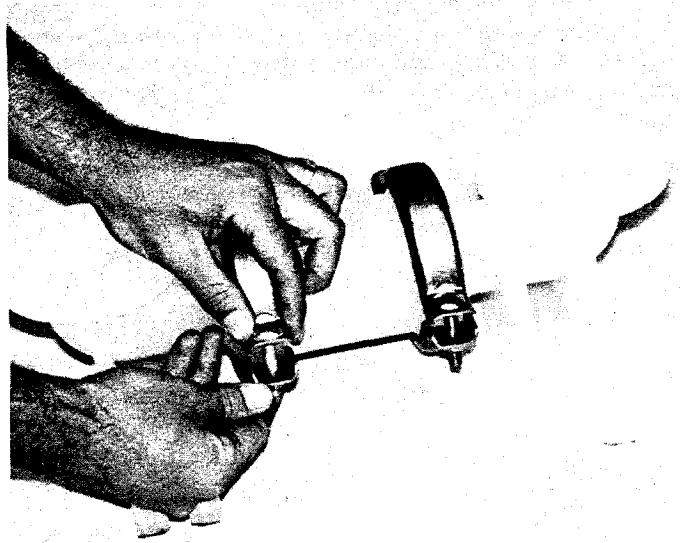

Figure 10B

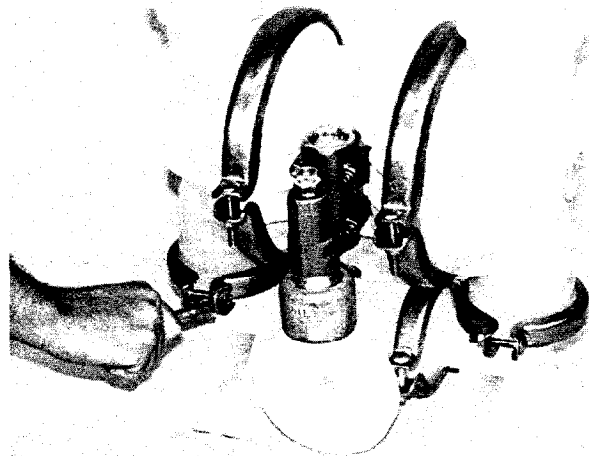

Figure 10C

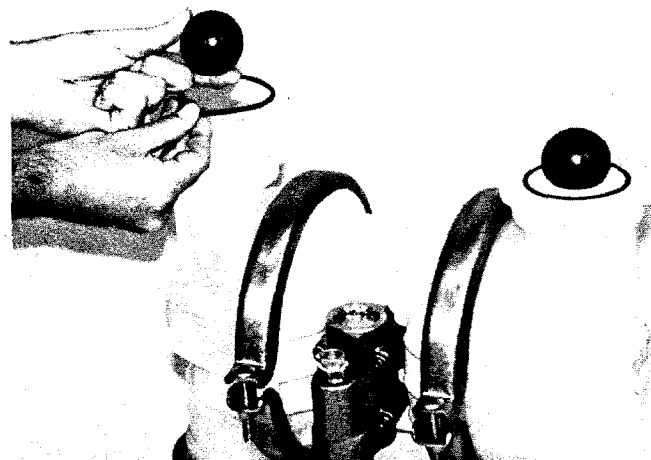

Figure 11

SECTION 6C

AIR VALVE / CENTER BLOCK DISASSEMBLY / REASSEMBLY

The air valve assembly consists of both the air valve body and piston and the center block. The unique design of the air valve relies only on differential pressure to effect the diaphragm shift. It is reliable and simple to maintain. The bushing in the center block, along with the diaphragm shaft, provides the "trigger" to tell the air valve to shift. The following procedure will ensure that the air valve on your Wilden pump will provide long trouble-free service.

AIR VALVE ASSEMBLY AND DISASSEMBLY:

The air valve (P/N 04-2000-07) can be disconnected from the pump by removing the four socket head cap screws which attach it to the center block. The piston should move freely and the ports in the piston should line up with the ports on the face of the air valve body (see *Figure D*). The piston should also appear to be dull, dark gray in color. If the piston appears to be a shiny aluminum color, the air valve is probably worn beyond working tolerances and should be replaced.

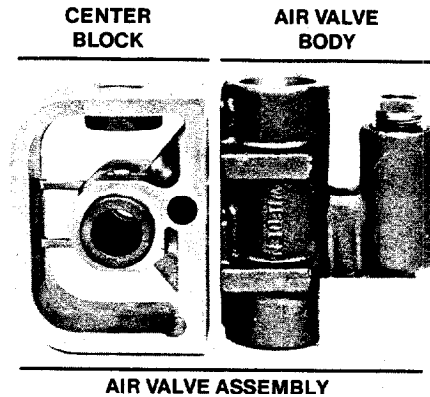

Figure A

If the piston does not move freely in the air valve, the entire air valve should be immersed in a cleaning solution. [NOTE: Do not force the piston by inserting a metal object.] This soaking should remove any accumulation of sludge and grit which is preventing the air valve piston from moving freely. Also, remove and clean the air valve screen (P/N 04-2500-03). If the air valve piston does not move freely after the above cleaning, the air valve should be disassembled as follows: Remove the snap ring from the top end of the air valve cylinder and apply an air jet to the 3/16-inch hole on the opposite end of the air valve face (see *Figure C*). **CAUTION:** The air valve end cap may come out with considerable force. Inspect the piston and cylinder bore for nicks and scoring.

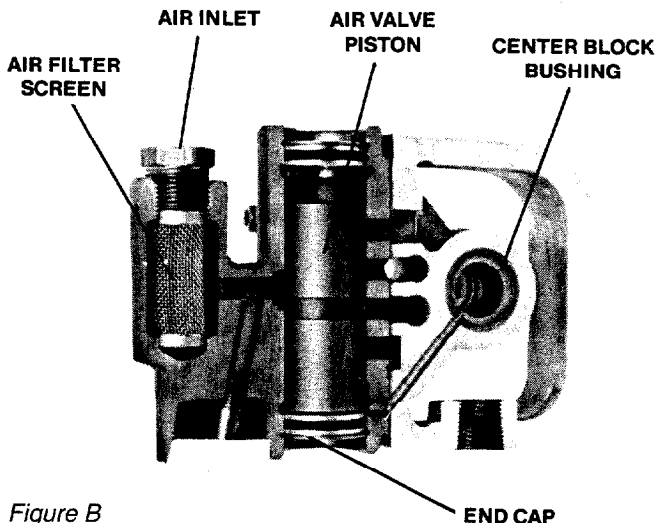

Figure B

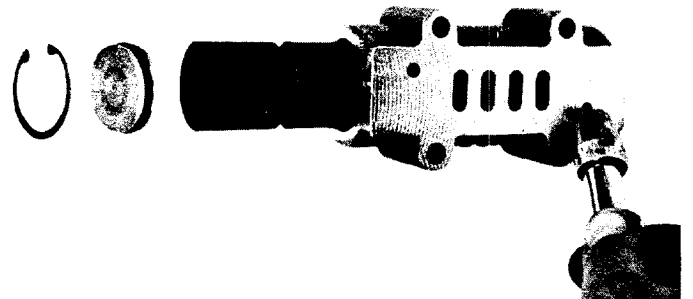

Figure C

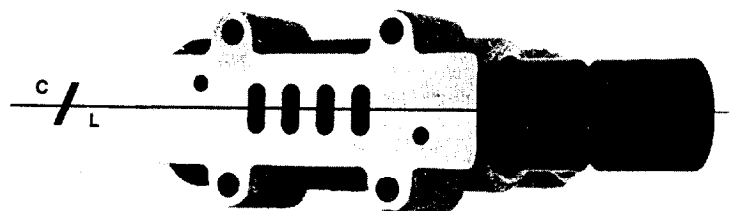

Figure D

Small nicks can usually be dressed out and the piston returned to service. Inspect the cylinder end caps (P/N 04-2300-23 has the piston guide pin and P/N 04-2330-23 does not.) Make sure that the guide pin is straight and smooth or the piston will not move freely in the cylinder. New O-rings (P/N 04-2390-52) should be installed on the end caps. Lubricate the O-rings with an arctic 5 weight hydraulic oil (ISO grade 15) and install the end caps, assuring that proper alignment of the piston and cylinder ports is maintained (see *Figure D*). Reinstall air valve to center block of pump. Tighten per the torque specification*.

O-RING REPLACEMENT:

When the O-rings become worn or flat, they will no longer seal and must be replaced. This is most easily accomplished by using a tool called an O-ring pick, available through most industrial supply companies.

CENTER BLOCK ASSEMBLY (P/N 04-3100-01):

The pump's center block (P/N 04-3100-01) consists of a die cast housing with a cast-in-bronze bushing (*Figure G*). *Figure H* shows M4 injection-molded polypropylene center section (P/N 04-3150-20) and alignment with air valve. The bushing has eleven grooves cut on the inside diameter. There are seven O-rings that fit in these grooves (see *Figure E*). Since these O-rings form a part of the shifting function of the pump, it is necessary that they be located in the proper grooves. The bronze bushing is replaceable in cast iron center block only. When bushing wear becomes excessive, a new center block must be used.

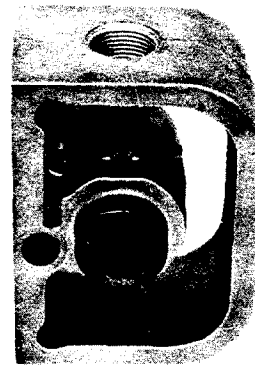

Figure F (Side View)

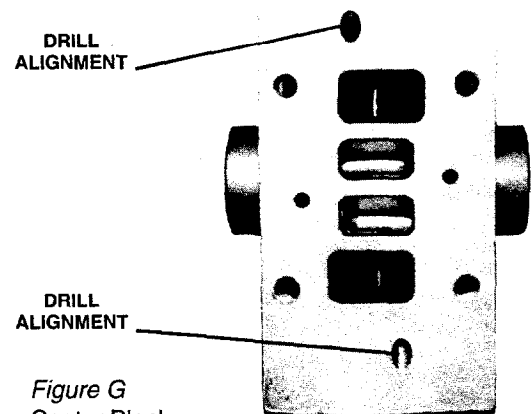

Figure G
Center Block
(Front View)

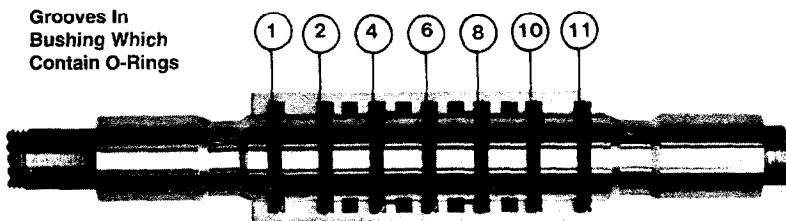

Figure E

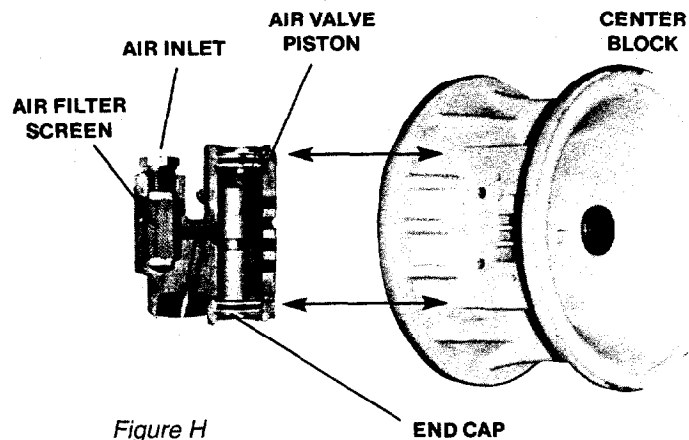

Figure H

*Refer to Section 8 for torque specifications.

SECTION 6D

TURBO 225 AIR DISTRIBUTION SYSTEM

The patent pending "TURBO 225" air distribution system is designed to combat the effect of "freezing." This condition can occur when air-operated, double-diaphragm pumps are operated on a moisture-laden air supply. Moisture held in suspension can crystallize to ice when the compressed air expands, pressure decreases, and temperature drops. The "TURBO 225" is designed to control the internal expansion of air, minimizing pressure and temperature reduction. By controlling the internal expansion of air and thus the crystallization of water to ice, the Wilden pump operates reliably without loss in performance.

The use of proprietary engineered thermoplastics decreases the coefficient of friction between mating parts enabling the pump to operate lubrication free intermittently. The solid piston with milled exhaust slots allows for efficient exhausting through the center section of the pump, reducing the "chilling effect" on the air valve piston. The thermoplastic air valve piston decreases the transfer of cold temperatures from the air exhaust to the main air supply further inhibiting "freezing" conditions.

In addition to the air valve changes, the center block O-rings have been replaced by a proprietary composite glide ring. This glide ring exhibits much longer life (5x the life of standard O-rings) and less susceptibility to chemical attack (hardening, shrinking, and/or cracking). No changes to center block grooves have been made, allowing these glide rings complete retrofittability to existing center blocks (see *Figure B*).

A straight shaft (non D-dented) must be utilized with the glide rings (see *Figure B*). This straight shaft reduces the coefficient of friction between it and the center block glide rings, extending the life of these seals.

Air Valve Assembly
P/N 02-2000-07-225

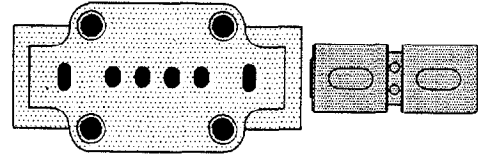
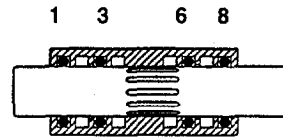

Figure A



ENHANCED CONFIGURATION

Figure B

SECTION 7A

M4 METAL

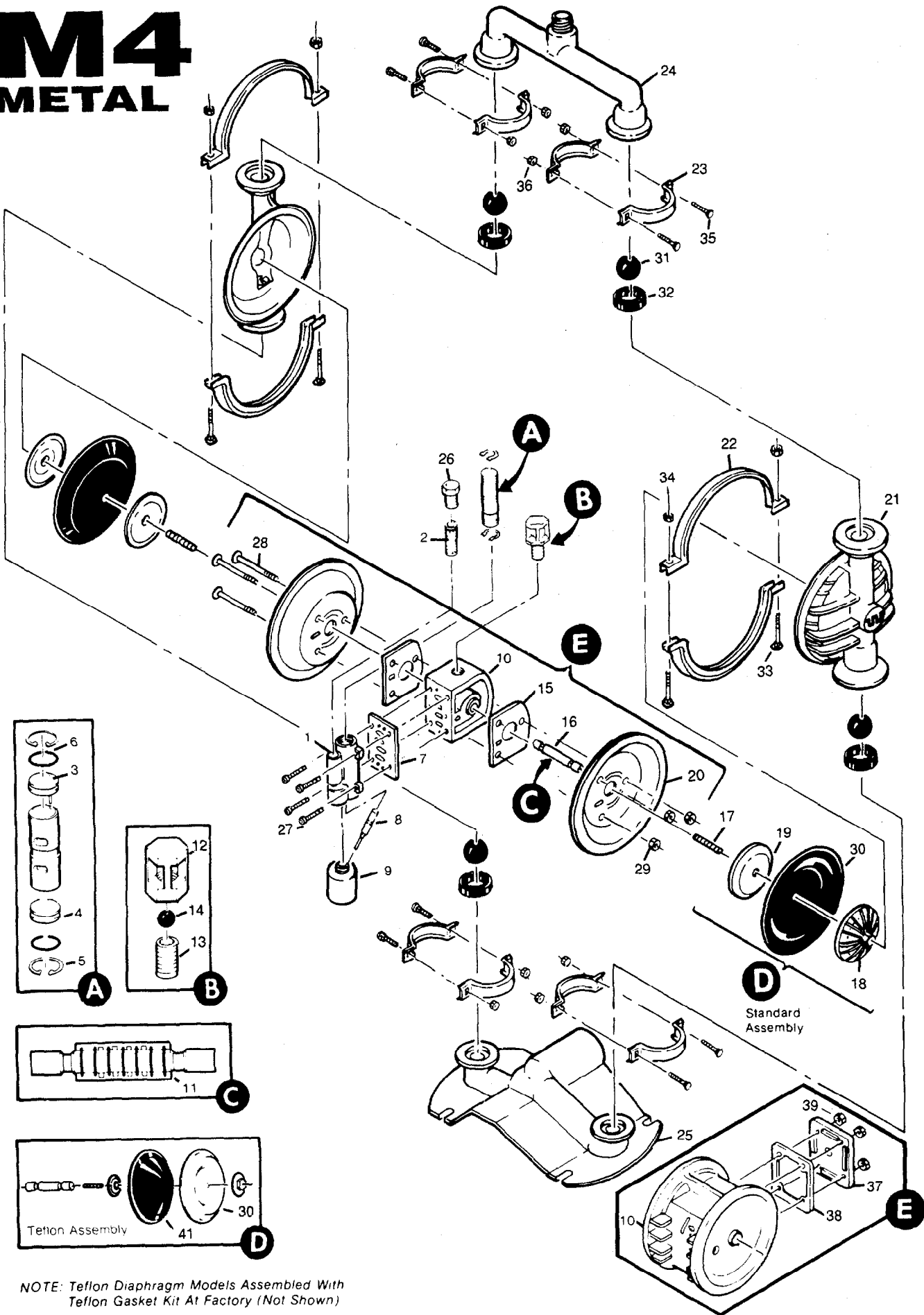

NOTE: Teflon Diaphragm Models Assembled With Teflon Gasket Kit At Factory (Not Shown)

M4 RUBBER/TPE-FITTED

| Item | Description | Qty. Per Pump | M4/AMAB | M4/APPB | M4-03/AMAB | M4-03/APPB | M4/HPPB | M4/SPPB | M4/SNNN | M4/WPPB | M4-22/WPPB | M4-70/SNNN | M4-70/SPPN |
|------|---|---------------|---------------|----------------|---------------|----------------|----------------|----------------|------------|----------------|----------------|----------------|----------------|
| | | | P/N | P/N | P/N | P/N | P/N | P/N | P/N | P/N | P/N | P/N | P/N |
| 1 | Air Valve | 1 | 04-2000-07 | 04-2000-07 | 04-2000-07 | 04-2000-07 | 04-2000-07 | 04-2000-07 | 04-2000-06 | 04-2000-07 | 04-2000-07 | 04-2000-06 | 04-2000-06 |
| 2 | Air Valve Screen | 1 | 04-2500-03 | 04-2500-03 | 04-2500-03 | 04-2500-03 | 04-2500-03 | 04-2500-03 | 04-2500-03 | 04-2500-03 | 04-2500-03 | 04-2500-03 | 04-2500-03 |
| 3 | Air Valve Cap w/Guide (Top) | 1 | 04-2300-23 | 04-2300-23 | 04-2300-23 | 04-2300-23 | 04-2300-23 | 04-2300-23 | 04-2300-23 | 04-2300-23 | 04-2300-23 | 04-2300-23 | 04-2300-23 |
| 4 | Air Valve Cap w/o Guide (Bottom) | 1 | 04-2330-23 | 04-2330-23 | 04-2330-23 | 04-2330-23 | 04-2330-23 | 04-2330-23 | 04-2330-23 | 04-2330-23 | 04-2330-23 | 04-2330-23 | 04-2330-23 |
| 5 | Snap Ring | 2 | 04-2650-03 | 04-2650-03 | 04-2650-03 | 04-2650-03 | 04-2650-03 | 04-2650-03 | 04-2650-03 | 04-2650-03 | 04-2650-03 | 04-2650-03 | 04-2650-03 |
| 6 | Air Valve Cap O-Ring | 2 | 04-2390-52 | 04-2390-52 | 04-2390-52 | 04-2390-52 | 04-2390-52 | 04-2390-52 | 04-2390-52 | 04-2390-52 | 04-2390-52 | 04-2390-52 | 04-2390-52 |
| 7 | Air Valve Gasket — Buna | 1 | 04-2600-52 | 04-2600-52 | 04-2600-52 | 04-2600-52 | 04-2600-52 | 04-2600-52 | 04-2600-52 | 04-2600-52 | 04-2600-52 | 04-2600-52 | 04-2600-52 |
| 8 | Lubricator Capillary Rod Assy. (optional) | 1 | 04-2900-99 | 04-2900-99 | 04-2900-99 | 04-2900-99 | 04-2900-99 | 04-2900-99 | 04-2900-99 | 04-2900-99 | 04-2900-99 | 04-2900-99 | 04-2900-99 |
| 9 | Lubricator Oil Bottle (optional) | 1 | 04-2850-01 | 04-2850-01 | 04-2850-01 | 04-2850-01 | 04-2850-01 | 04-2850-01 | 04-2850-01 | 04-2850-01 | 04-2850-01 | 04-2850-01 | 04-2850-01 |
| 10 | Center Section/Block | 1 | 04-3100-01 | 04-3150-20 | 04-3100-01 | 04-3150-20 | 04-3150-20 | 04-3150-20 | 04-3100-06 | 04-3150-20 | 04-3150-20 | 04-3100-06 | 04-3150-20 |
| 11 | O-Ring | 7 | 08-3200-52 | 08-3200-52 | 08-3200-52 | 08-3200-52 | 08-3200-52 | 08-3200-52 | 08-3200-52 | 08-3200-52 | 08-3200-52 | 08-3200-52 | 08-3200-52 |
| 12 | Check Body | 1 | 08-3550-01-30 | N/R | 08-3550-01-30 | N/R | N/R | N/R | 08-3550-06 | N/R | N/R | 08-3550-06 | N/R |
| 13 | Nipple | 1 | 08-7420-08 | N/R | 02-7470-03 | N/R | N/R | N/R | 02-7470-03 | N/R | N/R | 02-7470-03 | N/R |
| 14 | Check Ball | 1 | 08-1450-51 | N/R | 08-1450-51 | N/R | N/R | N/R | 08-1450-51 | N/R | N/R | 08-1450-51 | N/R |
| 15 | Block Gasket — Buna | 2 | 04-3520-52 | N/R | 04-3520-52 | N/R | N/R | N/R | 04-3520-52 | N/R | N/R | 04-3520-52 | N/R |
| 16 | Shaft | 1 | 04-3800-09 | 04-3800-09 | 04-3800-09 | 04-3800-09 | 04-3800-09 | 04-3800-09 | 04-3800-09 | 04-3800-09 | 04-3800-09 | 04-3800-09 | 04-3800-09 |
| 17 | Shaft Stud (M4/WPPB: Bolt) | 2 | NA | NA | NA | NA | 04-6150-08 | 04-6150-08 | 04-6150-08 | 04-6090-08 | 04-6090-08 | 04-6150-08 | 04-6150-08 |
| 18 | Piston, Outer | 2 | 04-4550-01 | 04-4550-01 | 04-4550-01 | 04-4550-01 | 04-4550-04 | 04-4550-03 | 04-4550-03 | 04-4550-08 | 04-4550-08 | 04-4550-03 | 04-4550-03 |
| 19 | Piston, Inner | 2 | 04-3700-08 | 04-3700-08 | 04-3700-08 | 04-3700-08 | 04-3700-08 | 04-3700-08 | 04-3700-08 | 04-3700-08 | 04-3700-08 | 04-3700-08 | 04-3700-08 |
| 20 | Air Chamber | 2 | 04-3650-08 | N/R | 04-3650-08 | N/R | N/R | N/R | 04-3650-06 | N/R | N/R | 04-3650-06 | N/R |
| 21 | Water Chamber | 2 | 04-5000-01 | 04-5000-01 | 04-5000-01 | 04-5000-01 | 04-5000-04 | 04-5000-03 | 04-5000-03 | 04-5000-02 | 04-5000-02 | 04-5000-03 | 04-5000-03 |
| 22 | Clamp Band (Large) | 2 | 04-7300-08 | 04-7330-08 | 04-7300-03 | 04-7330-03 | 04-7330-03 | 04-7330-03 | 04-7300-03 | 04-7330-08 | 04-7330-03 | 04-7300-03-70 | 04-7330-03-70 |
| 23 | Clamp Band (Small) | 4 | 04-7100-08 | 04-7100-08 | 04-7100-03 | 04-7100-03 | 04-7100-03 | 04-7100-03 | 04-7100-03 | 04-7100-08 | 04-7100-03 | 04-7100-03-70 | 04-7100-03-70 |
| 24 | Discharge Manifold | 1 | 04-5020-01 | 04-5020-01 | 04-5020-01-03 | 04-5020-01-03 | 04-5020-04 | 04-5020-03 | 04-5020-03 | 04-5020-02 | 04-5020-02 | 04-5020-03-70 | 04-5020-03-70 |
| 25 | Inlet Housing | 1 | 04-5080-01 | 04-5080-01 | 04-5080-01-03 | 04-5080-01-03 | 04-5080-04 | 04-5080-03 | 04-5080-03 | 04-5080-02 | 04-5080-02 | 04-5080-03-70 | 04-5080-03-70 |
| 26 | Reducer Bushing | 1 | 04-6950-07 | 04-6950-07 | 04-6950-07 | 04-6950-07 | 04-6950-07 | 04-6950-07 | 04-6950-03 | 04-6950-07 | 04-6950-07 | 04-6950-03 | 04-6950-03 |
| 27 | Air Valve Cap Screw | 4 | 04-6000-08 | 04-6000-03-500 | 04-6000-03 | 04-6000-03-500 | 04-6000-03-500 | 04-6000-03-500 | 04-6000-03 | 04-6000-03-500 | 04-6000-03-500 | 04-6000-03-500 | 04-6000-03-500 |
| 28 | Hex Head Cap Screw (Air Chamber) | 3 | 04-6130-08 | N/R | 04-6130-08 | N/R | N/R | N/R | 04-6130-08 | N/R | N/R | 04-6130-08 | N/R |
| 29 | Hex Head Nut (Air Chamber) | 3 | 04-6400-08 | N/R | 04-6400-08 | N/R | N/R | N/R | 04-6400-08 | N/R | N/R | 04-6400-08 | N/R |
| 30 | Diaphragm* | 2 | * | * | * | * | * | * | * | * | * | 04-1010-56 | 04-1010-56 |
| 31 | Valve Ball* | 4 | * | * | * | * | * | * | * | * | * | 04-1080-56 | 04-1080-56 |
| 32 | Valve Seat* | 4 | * | * | * | * | * | * | * | * | * | 04-1120-56 | 04-1120-56 |
| 33 | Large Clamp Band Bolt | 4 | 04-6070-08 | 04-6070-08 | 04-6070-03 | 04-6070-03 | 04-6070-03 | 04-6070-03 | 04-6070-03 | 04-6070-08 | 04-6070-03 | 04-6070-03 | 04-6070-03 |
| 34 | Large Hex Nut | 4 | 04-6420-08 | 04-6420-08 | 08-6400-03 | 08-6400-03 | 08-6400-03 | 08-6400-03 | 08-6400-03 | 04-6420-08 | 08-6400-03 | 08-6660-03-72 | 08-6660-03-72 |
| 35 | Small Clamp Band Bolt | 8 | 04-6050-08 | 04-6050-08 | 01-6070-03 | 01-6070-03 | 01-6070-03 | 01-6070-03 | 01-6070-03 | 04-6050-08 | 01-6070-03 | 01-6070-03 | 01-6070-03 |
| 36 | Small Hex Nut | 8 | 04-6400-08 | 04-6400-08 | 04-6400-03 | 04-6400-03 | 04-6400-03 | 04-6400-03 | 04-6400-03 | 04-6400-08 | 04-6400-03 | 04-6650-03-70 | 04-6650-03-70 |
| 37 | Muffler Plate | 1 | N/R | 04-3180-20 | N/R | 04-3180-20 | 04-3180-20 | 04-3180-20 | N/R | 04-3180-20 | 04-3180-20 | N/R | 04-3180-20 |
| 38 | Muffler Plate Gasket — Buna | 1 | N/R | 04-3500-52 | N/R | 04-3500-52 | 04-3500-52 | 04-3500-52 | N/R | 04-3500-52 | 04-3500-52 | N/R | 04-3500-52 |
| 39 | Air Valve Hex Nut | 4 | N/R | 04-6400-03 | N/R | 04-6400-03 | 04-6400-03 | 04-6400-03 | N/R | 04-6400-03 | 04-6400-03 | N/R | 04-6400-03 |

* — For optional M4 Metal Pump elastomers, see Section 8.

*NOTE — Muffler (P/N 04-3510-99) (not shown) is standard on all M4 pumps. (Comes equipped with P/N 08-3250-08 ¾ 45 degree street elbow for metal center section only.)

•NOTE — Muffler (P/N 08-3510-99) (not shown) is available upon request. (Comes equipped with P/N 08-3250-08 ¾ 45 degree street elbow.)

For Teflon®-fitted models, see next page.

SECTION 7B

M4 TEFLON®-FITTED

| Item | Description | Qty. Per Pump | M4/ APPB | M4-03/ APPB | M4/ HPPB | M4/ SPPB | M4/ WPPB | M4-70/ SNNN | M4-70/ SPPN |
|------|--|---------------|----------------|----------------|----------------|----------------|----------------|----------------|----------------|
| | | | P/N | P/N | P/N | P/N | P/N | P/N | P/N |
| 1 | Air Valve | 1 | 04-2000-07 | 04-2000-07 | 04-2000-07 | 04-2000-07 | 04-2000-07 | 04-2000-06 | 04-2000-06 |
| 2 | Air Valve Screen | 1 | 04-2500-03 | 04-2500-03 | 04-2500-03 | 04-2500-03 | 04-2500-03 | 04-2500-03 | 04-2500-03 |
| 3 | Air Valve Cap w/Guide (Top) | 1 | 04-2300-23 | 04-2300-23 | 04-2300-23 | 04-2300-23 | 04-2300-23 | 04-2300-23 | 04-2300-23 |
| 4 | Air Valve Cap w/o Guide (Bottom) | 1 | 04-2330-23 | 04-2330-23 | 04-2330-23 | 04-2330-23 | 04-2330-23 | 04-2330-23 | 04-2330-23 |
| 5 | Snap Ring | 2 | 04-2650-03 | 04-2650-03 | 04-2650-03 | 04-2650-03 | 04-2650-03 | 04-2650-03 | 04-2650-03 |
| 6 | Air Valve Cap O-Ring | 2 | 04-2390-52 | 04-2390-52 | 04-2390-52 | 04-2390-52 | 04-2390-52 | 04-2390-52 | 04-2390-52 |
| 7 | Air Valve Gasket — Buna | 1 | 04-2600-52 | 04-2600-52 | 04-2600-52 | 04-2600-52 | 04-2600-52 | 04-2600-52 | 04-2600-52 |
| 8 | Lubricator Capillary Rod Assy.' (optional) | 1 | 04-2900-99 | 04-2900-99 | 04-2900-99 | 04-2900-99 | 04-2900-99 | 04-2900-99 | 04-2900-99 |
| 9 | Lubricator Oil Bottle' (optional) | 1 | 04-2850-01 | 04-2850-01 | 04-2850-01 | 04-2850-01 | 04-2850-01 | 04-2850-01 | 04-2850-01 |
| 10 | Center Block | 1 | 04-3150-20 | 04-3150-20 | 04-3150-20 | 04-3150-20 | 04-3150-20 | 04-3100-06 | 04-3150-20 |
| 11 | O-Ring | 7 | 08-3200-52 | 08-3200-52 | 08-3200-52 | 08-3200-52 | 08-3200-52 | 08-3200-52 | 08-3200-52 |
| 12 | Check Body | 1 | N/R | N/R | N/R | N/R | N/R | 08-3550-06 | N/R |
| 13 | Nipple | 1 | N/R | N/R | N/R | N/R | N/R | 02-7470-03 | N/R |
| 14 | Check Ball | 1 | N/R | N/R | N/R | N/R | N/R | 08-1450-51 | N/R |
| 15 | Block Gasket — Buna | 2 | N/R | N/R | N/R | N/R | N/R | 04-3520-52 | N/R |
| 16 | Shaft | 1 | 04-3820-09 | 04-3820-09 | 04-3820-09 | 04-3820-09 | 04-3820-09 | 04-3820-09 | 04-3820-09 |
| 17 | Shaft Stud | 2 | 04-6150-08 | 04-6150-08 | 04-6150-08 | 04-6150-08 | 04-6150-08 | 04-6150-08 | 04-6150-08 |
| 18 | Piston, Outer | 2 | 04-4600-01 | 04-4600-01 | 04-4600-04 | 04-4600-03 | 04-4600-03 | 04-4600-03 | 04-4600-03 |
| 19 | Piston, Inner | 2 | 04-3750-01 | 04-3750-01 | 04-3750-01 | 04-3750-01 | 04-3750-01 | 04-3750-01 | 04-3750-01 |
| 20 | Air Chamber | 2 | N/R | N/R | N/R | N/R | N/R | 04-3650-06 | N/R |
| 21 | Water Chamber | 2 | 04-5000-01 | 04-5000-01 | 04-5000-04 | 04-5000-03 | 04-5000-02 | 04-5000-03 | 04-5000-03 |
| 22 | Clamp Band (Large) | 2 | 04-7330-03 | 04-7330-03 | 04-7330-03 | 04-7330-03 | 04-7330-03 | 04-7300-03-70 | 04-7330-03-70 |
| 23 | Clamp Band (Small) | 4 | 04-7100-03 | 04-7100-03 | 04-7100-03 | 04-7100-03 | 04-7100-03 | 04-7100-03-70 | 04-7100-03-70 |
| 24 | Discharge Manifold | 1 | 04-5020-01 | 04-5020-01-03 | 04-5020-04 | 04-5020-03 | 04-5020-02 | 04-5020-03-70 | 04-5020-03-70 |
| 25 | Inlet Housing | 1 | 04-5080-01 | 04-5080-01-03 | 04-5080-04 | 04-5080-03 | 04-5080-02 | 04-5080-03-70 | 04-5080-03-70 |
| 26 | Reducer Bushing | 1 | 04-6950-08 | 04-6950-07 | 04-6950-07 | 04-6950-07 | 04-6950-07 | 04-6950-03 | 04-6950-03 |
| 27 | Air Valve Cap Screw | 4 | 04-6000-03-500 | 04-6000-03-500 | 04-6000-03-500 | 04-6000-03-500 | 04-6000-03-500 | 04-6000-03-500 | 04-6000-03-500 |
| 28 | Hex Head Cap Screw | 3 | N/R | N/R | N/R | N/R | N/R | 04-6130-08 | N/R |
| 29 | Hex Head Nut | 3 | N/R | N/R | N/R | N/R | N/R | 04-6400-08 | N/R |
| 30 | Diaphragm | 2 | 04-1010-55 | 04-1010-55 | 04-1010-55 | 04-1010-55 | 04-1010-55 | 04-1010-55 | 04-1010-55 |
| 31 | Valve Ball | 4 | 04-1080-55 | 04-1080-55 | 04-1080-55 | 04-1080-55 | 04-1080-55 | 04-1080-55 | 04-1080-55 |
| 32 | Valve Seat | 4 | 04-1121-01 | 04-1121-01 | 04-1121-04 | 04-1121-03 | 04-1121-08 | 04-1121-03 | 04-1121-03 |
| 33 | Large Clamp Band Bolt | 4 | 04-6070-03 | 04-6070-03 | 04-6070-03 | 04-6070-03 | 04-6070-03 | 04-6070-03 | 04-6070-03 |
| 34 | Large Hex Nut | 4 | 08-6400-03 | 08-6400-03 | 08-6400-03 | 08-6400-03 | 08-6400-03 | 08-6660-03-72 | 08-6660-03-72 |
| 35 | Small Clamp Band Bolt | 8 | 01-6070-03 | 01-6070-03 | 01-6070-03 | 01-6070-03 | 01-6070-03 | 01-6070-03 | 01-6070-03 |
| 36 | Small Hex Nut | 8 | 04-6400-03 | 04-6400-03 | 04-6400-03 | 04-6400-03 | 04-6400-03 | 04-6650-03-70 | 04-6650-03-70 |
| 37 | Muffler Plate | 1 | 04-3180-20 | 04-3180-20 | 04-3180-20 | 04-3180-20 | 04-3180-20 | N/R | 04-3180-20 |
| 38 | Muffler Plate Gasket — Buna | 1 | 04-3500-52 | 04-3500-52 | 04-3500-52 | 04-3500-52 | 04-3500-52 | N/R | 04-3500-52 |
| 39 | Air Valve Hex Nut | 4 | 04-6400-03 | 04-6400-03 | 04-6400-03 | 04-6400-03 | 04-6400-03 | N/R | 04-6400-03 |
| 40 | Valve Seat O-Ring ² (not shown) | 4 | 04-1200-55 | 04-1200-55 | 04-1200-55 | 04-1200-55 | 04-1200-55 | 04-1200-55 | 04-1200-55 |
| 41 | Back-up Diaphragm** | 2 | 04-1060-56 | 04-1060-56 | 04-1060-56 | 04-1060-56 | 04-1060-56 | 04-1060-56 | 04-1060-56 |

¹Not required on current models.

²Fluoro-Seal™ O-rings available upon request.

*NOTE — Muffler (P/N 04-3510-99) (not shown) is standard on all pumps. (Metal center blocks come with a 45° street elbow.)

**Back-up Diaphragm for Teflon®-fitted pump: P/N 04-1060-56. Neoprene Back-up Diaphragm, P/N 04-1060-51, is available upon request for Teflon®-fitted pumps.

Please consult your local distributor.

SECTION 7C

**M4
CHAMP**

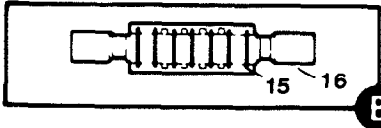
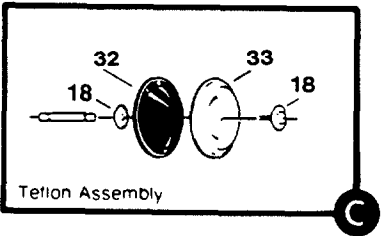
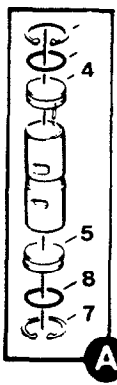
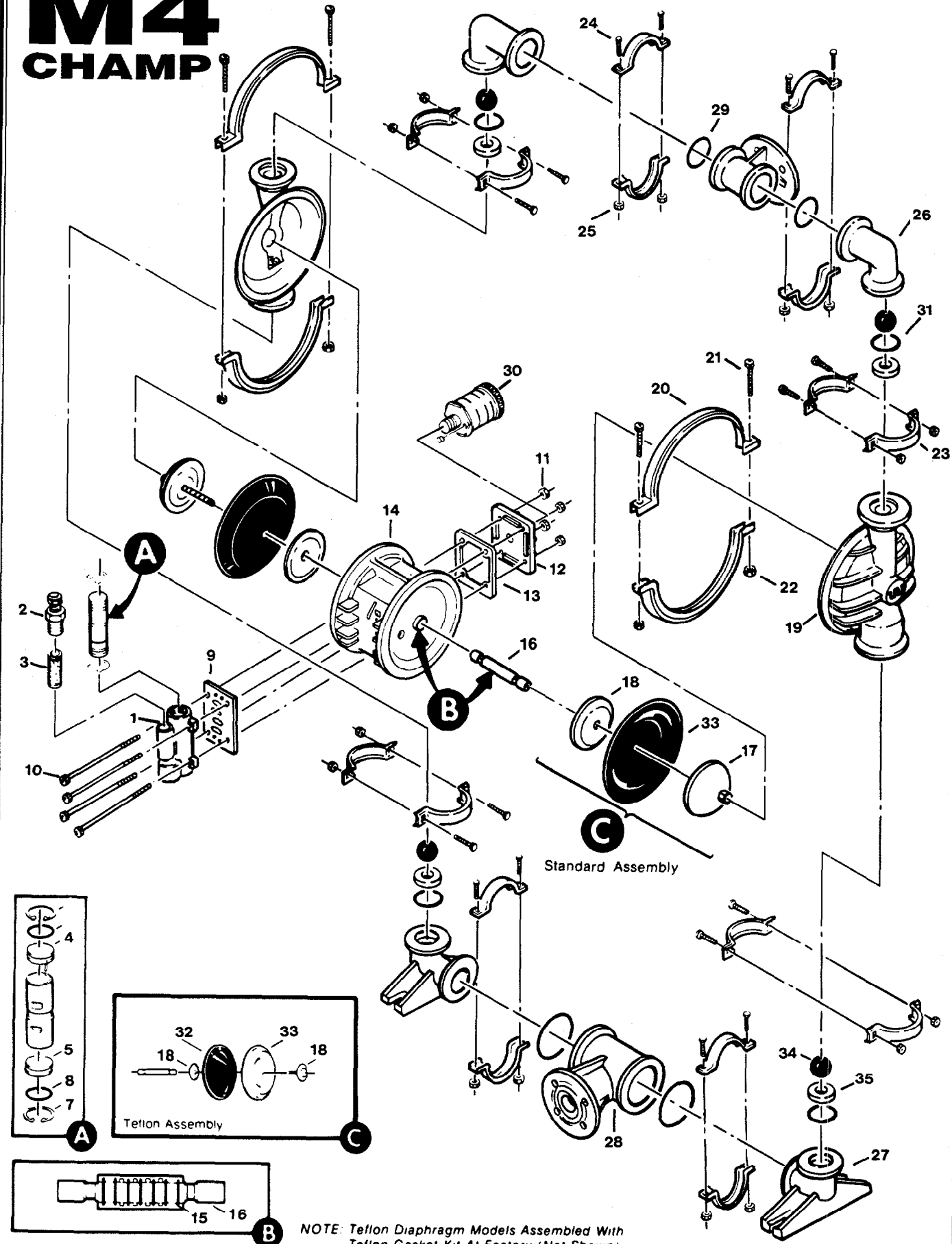

NOTE: Teflon Diaphragm Models Assembled With Teflon Gasket Kit At Factory (Not Shown)
FOR PART LISTING, SEE NEXT PAGE

Wilden Model M4 "Champ"

| | Part Description | Qty. Per Pump | Rubber-Fitted | | | | Teflon®-Fitted | | | | Ultrapure | | | |
|----|--|---------------|-------------------|-------------------|-------------------|-------------------|-------------------|-------------------|-------------------|-------------------|-------------------|-------------------|-----------------------|-----------------------|
| | | | M4/ PPPB Part No. | M4/ KPPB Part No. | M4/ PPPC Part No. | M4/ KPPC Part No. | M4/ PPPB Part No. | M4/ KPPB Part No. | M4/ PPPC Part No. | M4/ KPPC Part No. | M4/ TPPB Part No. | M4/ TPPC Part No. | M4-622/ TPPB Part No. | M4-612/ TPPC Part No. |
| 1 | Air Valve Assembly ¹ | 1 | 04-2000-07 | 04-2000-07 | 04-2000-05 | 04-2000-05 | 04-2000-07 | 04-2000-07 | 04-2000-05 | 04-2000-05 | 04-2000-07 | 04-2000-05 | 04-2000-07 | 04-2000-05 |
| 2 | Air Valve Bushing | 1 | 04-6950-07 | 04-6950-07 | 04-6950-05 | 04-6950-05 | 04-6950-07 | 04-6950-07 | 04-6950-05 | 04-6950-05 | 04-6950-07 | 04-6950-05 | 04-6950-07 | 04-6950-05 |
| 3 | Air Valve Screen | 1 | 04-2500-03 | 04-2500-03 | 04-2500-03 | 04-2500-03 | 04-2500-03 | 04-2500-03 | 04-2500-03 | 04-2500-03 | 04-2500-03 | 04-2500-03 | 04-2500-03 | 04-2500-03 |
| 4 | Air Valve with Guide (Top) | 1 | 04-2300-23 | 04-2300-23 | 04-2300-23 | 04-2300-23 | 04-2300-23 | 04-2300-23 | 04-2300-23 | 04-2300-23 | 04-2300-23 | 04-2300-23 | 04-2300-23 | 04-2300-23 |
| 5 | Air Valve Cap without End Guide (Bottom) | 1 | 04-2330-23 | 04-2330-23 | 04-2330-23 | 04-2330-23 | 04-2330-23 | 04-2330-23 | 04-2330-23 | 04-2330-23 | 04-2330-23 | 04-2330-23 | 04-2330-23 | 04-2330-23 |
| 6 | End Cap Cover (Not Shown) | 2 | N/A | N/A | 04-2420-55 | 04-2420-55 | N/A | N/A | 04-2420-55 | 04-2420-55 | N/R | 04-2420-55 | N/R | 04-2420-55 |
| 7 | Air Valve Snap Ring | 2 | 04-2650-03 | 04-2650-03 | 04-2650-03 | 04-2650-03 | 04-2650-03 | 04-2650-03 | 04-2650-03 | 04-2650-03 | 04-2650-03 | 04-2650-03 | 04-2650-03 | 04-2650-03 |
| 8 | Air Valve Cap O-Ring | 2 | 04-2390-52 | 04-2390-52 | 04-2390-52 | 04-2390-52 | 04-2390-52 | 04-2390-52 | 04-2390-52 | 04-2390-52 | 04-2390-52 | 04-2390-52 | 04-2390-52 | 04-2390-52 |
| 9 | Air Valve Gasket — Buna | 1 | 04-2600-52 | 04-2600-52 | 04-2600-52 | 04-2600-52 | 04-2600-52 | 04-2600-52 | 04-2600-52 | 04-2600-52 | 04-2600-52 | 04-2600-52 | 04-2600-52 | 04-2600-52 |
| 10 | Air Valve Cap Screw | 4 | 04-6000-03-500 | 04-6000-03-500 | 04-6000-05-502 | 04-6000-05-502 | 04-6000-03-500 | 04-6000-03-500 | 04-6000-05-502 | 04-6000-05-502 | 04-6000-03-500 | 04-6000-03-500 | 04-6000-03-500 | 04-6000-05-502 |
| 11 | Air Valve Hex Nut | 4 | 04-6400-03 | 04-6400-03 | 04-6400-05 | 04-6400-05 | 04-6400-03 | 04-6400-03 | 04-6400-05 | 04-6400-05 | 04-6400-03 | 04-6400-03 | 04-6400-03 | 04-6400-05 |
| 12 | Muffler Plate | 1 | 04-3180-20 | 04-3180-20 | 04-3180-20 | 04-3180-20 | 04-3180-20 | 04-3180-20 | 04-3180-20 | 04-3180-20 | 04-3180-20 | 04-3180-20 | 04-3180-20 | 04-3180-20 |
| 13 | Muffler Plate Gasket — Buna | 1 | 04-3500-52 | 04-3500-52 | 04-3500-52 | 04-3500-52 | 04-3500-52 | 04-3500-52 | 04-3500-52 | 04-3500-52 | 04-3500-52 | 04-3500-52 | 04-3500-52 | 04-3500-52 |
| 14 | Center Section | 1 | 04-3150-20 | 04-3150-20 | 04-3150-20 | 04-3150-20 | 04-3150-20 | 04-3150-20 | 04-3150-20 | 04-3150-20 | 04-3150-20 | 04-3150-20 | 04-3150-20 | 04-3150-20 |
| 15 | Center Section O-Ring | 7 | 08-3200-52 | 08-3200-52 | 08-3200-52 | 08-3200-52 | 08-3200-52 | 08-3200-52 | 08-3200-52 | 08-3200-52 | 08-3200-52 | 08-3200-52 | 08-3200-52 | 08-3200-52 |
| 16 | Shaft | 1 | 04-3800-09 | 04-3800-09 | 04-3800-09 | 04-3800-09 | 04-3820-09 | 04-3820-09 | 04-3820-09 | 04-3820-09 | 04-3820-09 | 04-3820-09 | 04-3820-09 | 04-3820-09 |
| 17 | Piston, Outer | 2 | 04-4550-20-500 | 04-4550-21-500 | 04-4550-20-500 | 04-4550-21-500 | 04-4600-20-500 | 04-4600-21-500 | 04-4600-20-500 | 04-4600-21-500 | 04-4600-22-500 | 04-4600-22-500 | 04-4600-22-500 | 04-4600-22-500 |
| 18 | Piston, Inner | 2 | 04-3700-08 | 04-3700-08 | 04-3700-08 | 04-3700-08 | 04-3750-01 | 04-3750-01 | 04-3750-01 | 04-3750-01 | 04-3750-01 | 04-3750-01 | 04-3750-01 | 04-3750-01 |
| 19 | Water Chamber | 2 | 04-5000-20 | 04-5000-21 | 04-5000-20 | 04-5000-21 | 04-5000-20 | 04-5000-21 | 04-5000-20 | 04-5000-21 | 04-5000-22 | 04-5000-22 | 04-5000-22 | 04-5000-22 |
| 20 | Large Clamp Band | 2 | 04-7300-03-500 | 04-7300-03-500 | 04-7300-05-502 | 04-7300-05-502 | 04-7300-03-500 | 04-7300-03-500 | 04-7300-05-502 | 04-7300-05-502 | 04-7300-03-500 | 04-7300-03-500 | 04-7300-03-500 | 04-7300-05-502 |
| 21 | Large Carriage Bolt | 4 | 04-6070-03 | 04-6070-03 | 04-6070-05 | 04-6070-05 | 04-6070-03 | 04-6070-03 | 04-6070-05 | 04-6070-05 | 04-6070-03 | 04-6070-03 | 04-6070-03 | 04-6070-05 |
| 22 | Hex Nut | 4 | 08-6400-03 | 08-6400-03 | 08-6400-05 | 08-6400-05 | 08-6400-03 | 08-6400-03 | 08-6400-05 | 08-6400-05 | 08-6400-03 | 08-6400-03 | 08-6400-03 | 08-6400-05 |
| 23 | Small Clamp Band | 8 | 04-7100-03-500 | 04-7100-03-500 | 04-7100-05-502 | 04-7100-05-502 | 04-7100-03-500 | 04-7100-03-500 | 04-7100-05-502 | 04-7100-05-502 | 04-7100-03-500 | 04-7100-03-500 | 04-7100-03-500 | 04-7100-05-502 |
| 24 | Small Carriage Bolt | 16 | 08-6050-03-500 | 08-6050-03-500 | 08-6050-05-502 | 08-6050-05-502 | 08-6050-03-500 | 08-6050-03-500 | 08-6050-05-502 | 08-6050-05-502 | 08-6050-03-500 | 08-6050-03-500 | 08-6050-03-500 | 08-6050-05-502 |
| 25 | Hex Nut | 16 | 08-6400-03 | 08-6400-03 | 08-6400-05 | 08-6400-05 | 08-6400-03 | 08-6400-03 | 08-6400-05 | 08-6400-05 | 08-6400-03 | 08-6400-03 | 08-6400-03 | 08-6400-05 |
| 26 | Discharge Elbow | 2 | 04-5230-20 | 04-5230-21 | 04-5230-20 | 04-5230-21 | 04-5230-20 | 04-5230-21 | 04-5230-20 | 04-5230-21 | 04-5230-22 | 04-5230-22 | 04-5230-22 | 04-5230-22 |
| 27 | Inlet Elbow | 2 | 04-5220-20 | 04-5220-21 | 04-5220-20 | 04-5220-21 | 04-5220-20 | 04-5220-21 | 04-5220-20 | 04-5220-21 | 04-5220-22 | 04-5220-22 | 04-5220-22 | 04-5220-22 |
| 28 | Manifold Tee Section ² | 2 | 04-5160-20 | 04-5160-21 | 04-5160-20 | 04-5160-21 | 04-5160-20 | 04-5160-21 | 04-5160-20 | 04-5160-21 | 04-5160-22 | 04-5160-22 | 04-5160-22-552 | 04-5160-22-552 |
| 29 | Tee-Section O-Ring | 4 | * | * | * | * | 04-1300-59-500 | 04-1300-60-500 | 04-1300-59-500 | 04-1300-60-500 | 04-1300-60-500 | 04-1300-60-500 | 04-1300-60-500 | 04-1300-60-500 |
| 30 | Muffler (Consult Factory) | 1 | 04-3510-99 | 04-3510-99 | 04-3510-99 | 04-3510-99 | 04-3510-99 | 04-3510-99 | 04-3510-99 | 04-3510-99 | 04-3510-99 | 04-3510-99 | 04-3510-99 | 04-3510-99 |
| 31 | Valve Seat O-Ring | 4 | * | * | * | * | 04-1200-59-500 | 04-1200-60-500 | 04-1200-59-500 | 04-1200-60-500 | 04-1200-60-500 | 04-1200-60-500 | 04-1200-60-500 | 04-1200-60-500 |
| 32 | Back-up Diaphragm** | 2 | N/R | N/R | N/R | N/R | 04-1060-56 | 04-1060-56 | 04-1060-56 | 04-1060-56 | 04-1060-56 | 04-1060-56 | 04-1060-56 | 04-1060-56 |
| 33 | Diaphragm | 2 | * | * | * | * | 04-1010-55 | 04-1010-55 | 04-1010-55 | 04-1010-55 | 04-1010-55 | 04-1010-55 | 04-1010-55 | 04-1010-55 |
| 34 | Valve Ball | 4 | * | * | * | * | 04-1080-55 | 04-1080-55 | 04-1080-55 | 04-1080-55 | 04-1080-55 | 04-1080-55 | 04-1080-55 | 04-1080-55 |
| 35 | Valve Seat | 4 | 04-1120-20-500 | 04-1120-21-500 | 04-1120-20-500 | 04-1120-21-500 | 04-1120-20-500 | 04-1120-21-500 | 04-1120-20-500 | 04-1120-21-500 | 04-1120-22-500 | 04-1120-22-500 | 04-1120-22-500 | 04-1120-22-500 |
| 36 | Teflon® Gasket Kit (Not Shown) | 1 | N/R | N/R | N/R | N/R | 08-9500-99 | 08-9500-99 | 08-9500-99 | 08-9500-99 | 08-9500-99 | 08-9500-99 | 08-9500-99 | 08-9500-99 |

* Refer to M4 "Champ" Elastomer Chart below.

** Back-up Diaphragm for Teflon®-fitted pump: P/N 04-1060-56. Neoprene Back-up Diaphragm, P/N 04-1060-51, is available upon request for Teflon®-fitted pumps. Please consult your local distributor.

¹Air Valve Assembly includes items 2 through 8.

²DIN Flange: Polypropylene = 04-5160-20-504 PVDF = 04-5160-21-504

NOTE: Models M4-622/TPPR and M4-612/TPPC incorporate 1" male non-threaded inlet/discharge bondable connections.

SECTION 8

ELASTOMER OPTIONS & TORQUE SPECIFICATIONS FOR MODEL M4 (METAL AND PLASTIC)

M4 Metal Elastomer Options

| Material | Diaphragms (2) | Valve Balls (4) | Valve Seats (4) | Valve Seat O-Rings (4) |
|-----------------|----------------|-----------------|-----------------|------------------------|
| Neoprene | 04-1010-51 | 04-1080-51 | 04-1120-51 | NA |
| Polyurethane | 04-1010-50 | 04-1080-50 | 04-1120-50 | NA |
| Buna N | 04-1010-52 | 04-1080-52 | 04-1120-52 | NA |
| Wil-flex™ | 04-1010-58 | 04-1080-58 | 04-1120-58 | NA |
| Saniflex™ | 04-1010-56 | 04-1080-56 | 04-1120-56 | NA |
| Nordel | 04-1010-54 | 04-1080-54 | 04-1120-54 | NA |
| Viton | 04-1010-53 | 04-1080-53 | 04-1120-53 | NA |
| Fluoro-Seal™ | N/A | N/A | N/A | 04-1200-34 |
| Teflon® PTFE | 04-1010-55 | 04-1080-55 | NA | 04-1200-55 |
| Aluminum | NA | NA | 04-1121-01 | NA |
| Carbon Steel | NA | NA | 04-1121-08 | NA |
| Stainless Steel | NA | NA | 04-1121-03 | NA |
| Hastelloy | NA | NA | 04-1121-04 | NA |

M4 "Champ" Elastomer Options

| Material | Diaphragms (2) | Valve Balls (4) | Valve Seats (4) | Valve Seat O-Rings (4) | Tee-Section O-Rings (4) |
|--------------------------|----------------|-----------------|-----------------|------------------------|-------------------------|
| Neoprene | 04-1010-51 | 04-1080-51 | NA | NA | NA |
| Polyurethane | 04-1010-50 | 04-1080-50 | NA | 04-1200-50-500 | NA |
| Buna N | 04-1010-52 | 04-1080-52 | NA | 04-1200-52-500 | 04-1300-52-500 |
| Wil-flex™ | 04-1010-58 | 04-1080-58 | NA | NA | NA |
| Saniflex™ | 04-1010-56 | 04-1080-56 | NA | NA | NA |
| Nordel | 04-1010-54 | 04-1080-54 | NA | NA | NA |
| Viton | 04-1010-53 | 04-1080-53 | NA | NA | NA |
| Teflon® PTFE | 04-1010-55 | 04-1080-55 | NA | NA | NA |
| Teflon® PFA | NA | NA | 04-1120-22-500 | NA | NA |
| Teflon® Encap. (Viton) | NA | NA | NA | 04-1200-60-500 | 04-1300-60-500 |
| Teflon® Encap. (Silicon) | NA | NA | NA | 04-1200-59-500 | 04-1300-59-500 |
| Polypropylene | NA | NA | 04-1120-20-500 | NA | NA |
| PVDF | NA | NA | 04-1120-21-500 | NA | NA |

Torque Specifications

| Item # | Description of Part | Maximum Torque | |
|--------|----------------------------------|-------------------------|-------------------------|
| | | Metal Pumps | Plastic Pumps |
| 1 | Air Valve | 30 in.-lbs. [3.4 m-N] | 30 in.-lbs. [3.4 m-N] |
| 2 | Outer Piston | 33 ft.-lbs. [44.7 m-N] | 38 ft.-lbs. [51.5 m-N] |
| 3 | Small Clamp Band | 30 in.-lbs. [3.4 m-N] | 85 in.-lbs. [9.6 m-N] |
| 4 | Large Clamp Band (Rubber-Fitted) | 95 in.-lbs. [10.7 m-N] | 165 in.-lbs. [18.6 m-N] |
| 5 | Large Clamp Band (Teflon-Fitted) | 120 in.-lbs. [13.5 m-N] | 165 in.-lbs. [18.6 m-N] |
| 6 | Center Block Assembly | 75 in.-lbs. [8.5 m-N] | — |

WILDEN'S SPECIALTY PUMPS

M8 STALLION

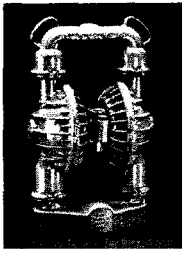

2" inlet. Solids clearance up to 3/4". Built to handle rough treatment: cast-in handles for easy portability, reinforced shaft and high impact polyurethane base.

SOLENOID-OPERATED

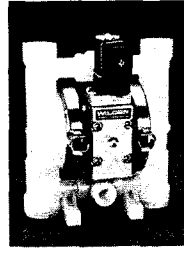

Each stroke of this pump is controlled by electrical impulses making it ideal for batching, metering, and other electrically controlled dispensing applications.

M1 ULTRAPURE III

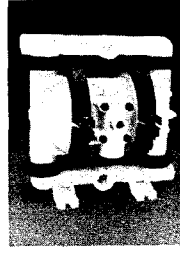

1/2" inlet. Teflon® PFA construction, temperatures to 300°F. Up to 14 GPM. Materials of construction have been selected to reduce contamination while providing a safer work environment.

FOOD PROCESSING

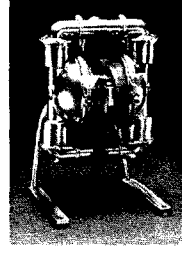

Constructed with FDA approved materials: bead blasted 316 Stainless Steel construction with tri-clamp porting and wing-nut fasteners. Foodmaster™ (pictured) is USDA accepted.

THE WILDEN PUMP LINE

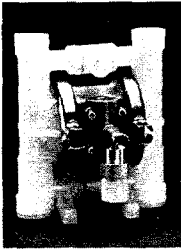

M.025
(CHAMP SERIES)

MODEL M.025

- 1/4" Inlet
- Up To 4.5 GPM
- 125 Max. PSIG
- Max. Particle Size: 1/16"

Materials of Construction:
PVDF, Acetal, Polypropylene, Carbon-filled Acetal

Suction Lift:
(Rubber) Dry: 4.5'
Wet: 25'
(Teflon®) Dry: 4.5'
Wet: 25'

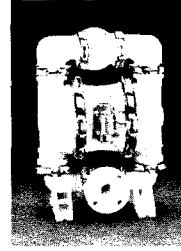

M4 PLASTIC
(CHAMP SERIES)

MODEL M4

- 1 1/2" Inlet
- Up To 73 GPM
- 125 Max. PSIG
- Max. Particle Size: 1/16"

Materials of Construction:
Aluminum, Cast Iron, Stainless Steel, Hastelloy, Polypropylene, PVDF, Teflon® PFA

Suction Lift:
(Rubber) **Plastic** Dry: 17'
Wet: 25'
(Teflon®) **Metal** Dry: 21'
Wet: 25'

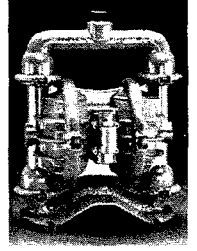

M4 METAL

LUBE-FREE AVAILABLE

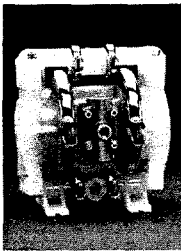

M1 PLASTIC
(CHAMP SERIES)

MODEL M1

- 1/2" Inlet
- Up To 14 GPM
- 110 Max. PSIG
- Max. Particle Size: 1/16"

Materials of Construction:
Polypropylene, PVDF, Teflon®, Graphite-filled Polypropylene, Aluminum, Stainless Steel

Suction Lift:
(Rubber) **Plastic** Dry: 10'
Wet: 25'
(Teflon®) **Metal** Dry: 10'
Wet: 25'

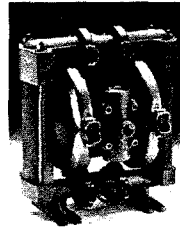

M1 METAL

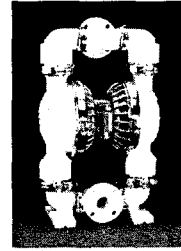

M8 PLASTIC
(CHAMP SERIES)

MODEL M8

- 2" Inlet
- Up To 155 GPM
- 125 Max. PSIG
- Max. Particle Size: 1/4"

Materials of Construction:
Aluminum, Cast Iron, Stainless Steel, Hastelloy, PVDF, Polypropylene

Suction Lift:
(Rubber) **Plastic** Dry: 17'
Wet: 25'
(Teflon®) **Metal** Dry: 20'
Wet: 25'

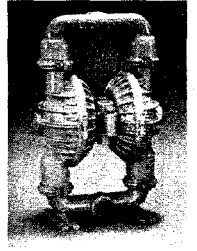

M8 METAL

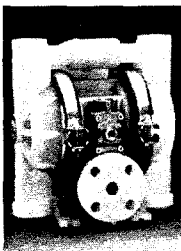

M2R PLASTIC
(CHAMP SERIES)

MODEL M2

- 1" Inlet
- Up To 37 GPM
- 125 Max. PSIG
- Max. Particle Size: 1/8"

Materials of Construction:
Aluminum, Stainless Steel, Hastelloy, Polypropylene, PVDF

Suction Lift:
(Rubber) **Plastic** Dry: 17'
Wet: 25'
(Teflon®) **Metal** Dry: 19'
Wet: 25'

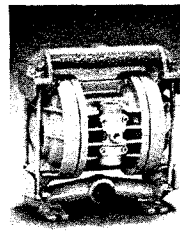

M2 METAL

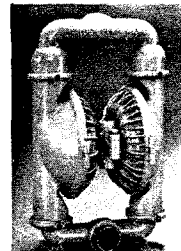

M15

MODEL M15

- 3" Inlet
- Up To 230 GPM
- 125 Max. PSIG
- Max. Particle Size: 3/8"

Materials of Construction:
Aluminum, Cast Iron, Stainless Steel, Hastelloy

Suction Lift:
(Rubber) Dry: 17'
Wet: 25'
(Teflon®) Dry: 14'
Wet: 25'

For further information contact your local Wilden distributor:

TERCATA MACHINERY CO.
P. O. BOX 3407
WILMINGTON, NC 28406-0407
PHONE (910) 799-3800
FAX (910) 799-8801

WILDEN PUMP & ENGINEERING COMPANY

22069 Van Buren St., Grand Terrace, CA 92313-5651
(909) 422-1730 • FAX (909) 783-3440

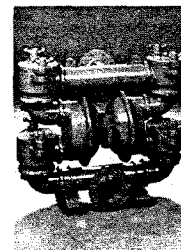

M20

MODEL M20

- 4" Inlet
- Up To 304 GPM
- 125 Max. PSIG
- Max. Particle Size: 1 1/2"

Materials of Construction:
Cast Iron

Suction Lift:
Dry: 13'
Wet: 25'

THE EQUALIZER™

WILDEN AUTOMATIC SURGE DAMPENER

SD1 & SD2 Engineering Operation and Maintenance

SD1 EQUALIZER™

1" inlet and discharge. For use on Wilden pump models M1, M2 and M4. Available in polypropylene, PVDF, Teflon PFA, aluminum, and 316 S.S.

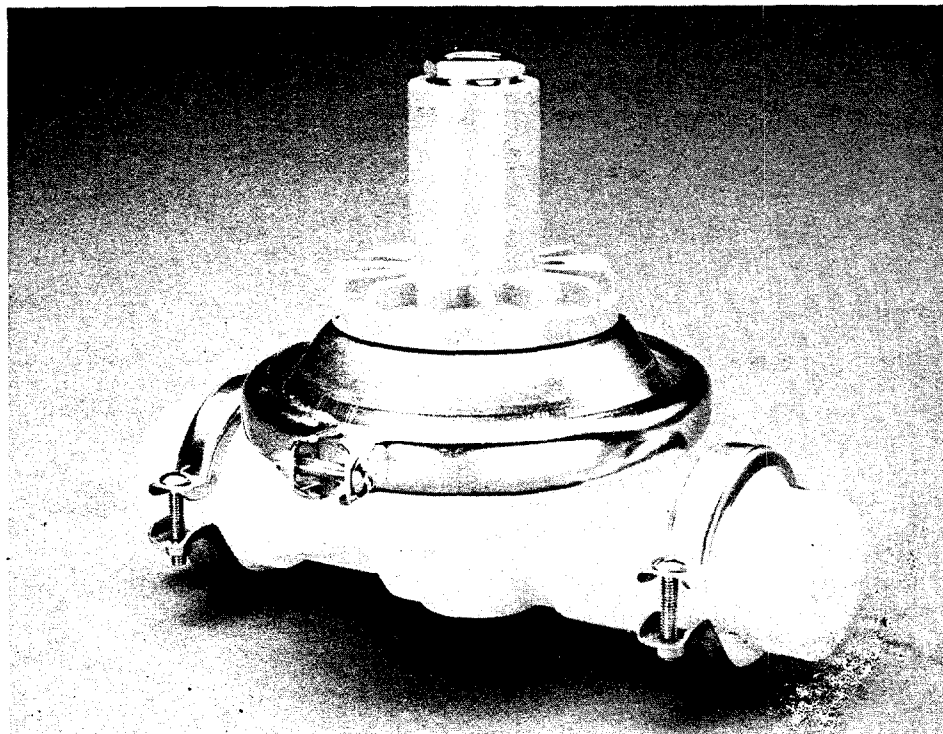

SD2 EQUALIZER™

2" inlet and discharge. For use on Wilden pump models M4 and M8. Available in polypropylene, PVDF, aluminum, cast iron and 316 S.S.

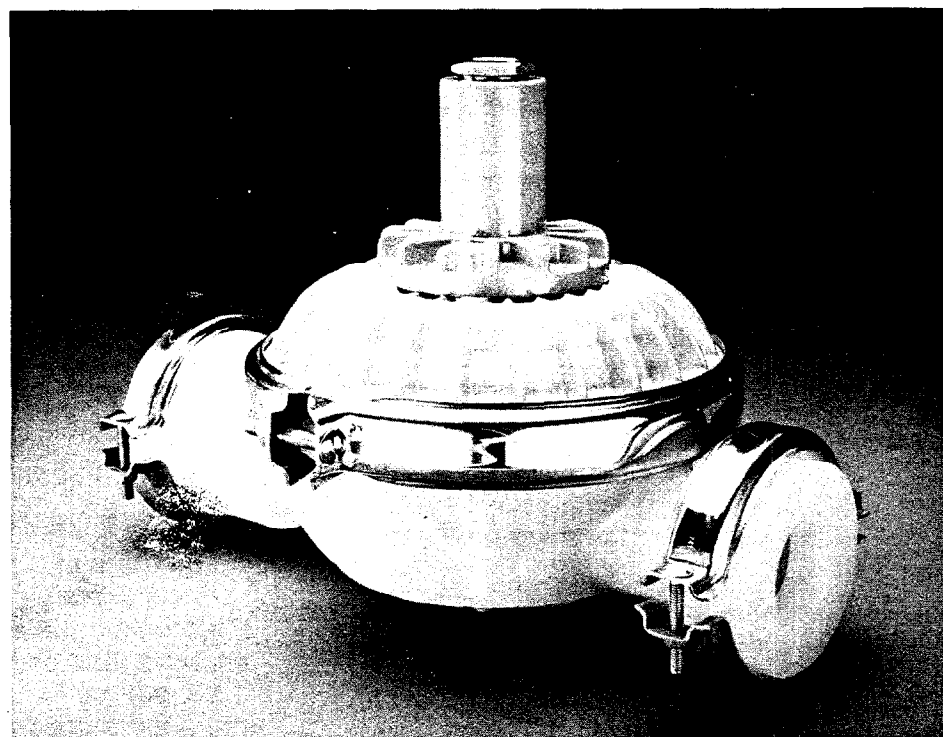

THE EQUALIZER™

All reciprocating pumps experience a pressure fluctuation. The Equalizer™ minimizes unwanted pressure fluctuation by providing a supplementary pumping action. This is accomplished by using a diaphragm as a separation membrane within the Equalizer™ to trap a given volume of liquid on one side and pressurized air on the other. When the fluid pressure falls in the system, the Equalizer™ supplies additional pressure to the discharge line between pump strokes by displacing fluid via diaphragm movement. This movement provides the supplementary pumping action needed to virtually eliminate pressure variation and pulsation.

The Equalizer™ automatically sets and maintains the correct air pressure matching the variations in liquid flow or discharge pressure generated by the pump. A shaft attached to the Equalizer™ diaphragm triggers the addition or deletion of the air within the non-wetted side of the Equalizer™. The Equalizer™ automatically adjusts to any pressure and/or flow setting of the pump with no need for manual adjustment of the unit and/or system. The Equalizer™ has proven to be the cost effective choice for protecting your liquid process system from unwanted pulsation or pressure fluctuation. Contact your local Wilden distributor for further information on the Equalizer™ and other pumping solutions.

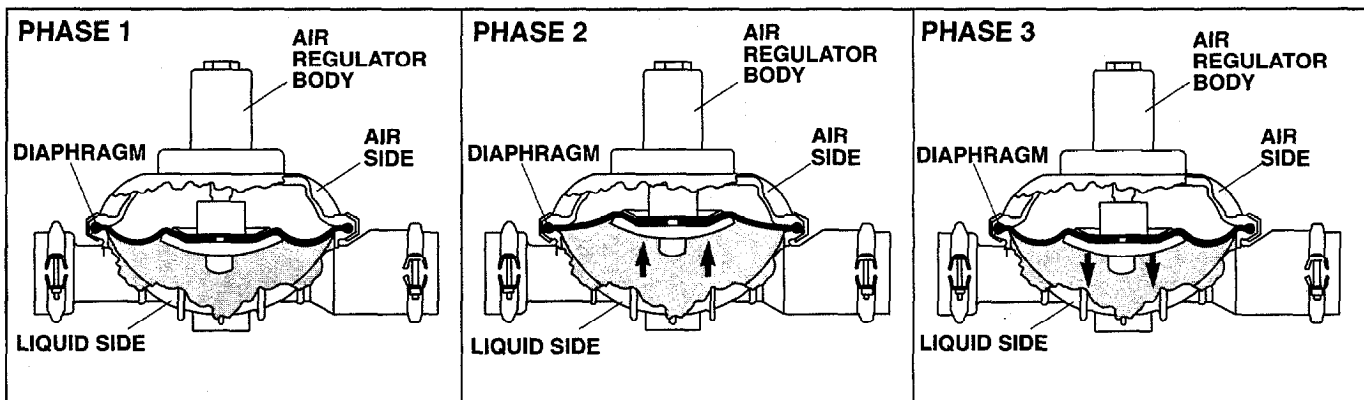

A compressed air line attached to the air regulator body sets and maintains pressure on the air side of the diaphragm. As the reciprocating pump begins its stroke, liquid discharge pressure increases which flexes the Equalizer™ diaphragm inward. This action accumulates fluid in the liquid chamber (see phase 2). When

the pump redirects its motion upon stroke completion, the liquid discharge pressure decreases forcing the Equalizer™ diaphragm to flex outward displacing the fluid into the discharge line (see phase 3). This motion provides the supplementary pumping action needed to minimize pressure fluctuation.

CAUTION: DO NOT EXCEED 125 PSIG AIR PRESSURE.

Maximum temperature limits are based upon mechanical stress only. Certain chemicals will significantly reduce maximum safe operating temperatures. Consult Wilden Chemical Guide for chemical compatibility and temperature limits.

Plastic Equalizers are manufactured with virgin plastic and are not UV stabilized. Direct sunlight for prolonged periods can cause deterioration of these plastics. In this situation a metal Equalizer™ is suggested.

Wear safety glasses. When diaphragm rupture occurs, material being pumped may be forced out air exhaust.

WARNING

Prevention of static sparking — If static sparking occurs, fire or explosion could result. Pump, Equalizer™, valves, and containers must be grounded when handling flammable fluids and whenever discharge of static electricity is a hazard.

THE WILDEN EQUALIZER™

AUTOMATIC SURGE DAMPENER

BENEFITS:

- Creates laminar flow.
- Minimizes pipe strain.
- Protects in-line equipment.
- Reduces water hammer.
- Absorbs acceleration head.
- Lowers system maintenance costs.

FEATURES:

- Clamp band construction for ease of maintenance.
- Automatically adjusts to any pressure and/or flow setting of the pump.
- Wide variety of materials to satisfy temperature and chemical compatibility considerations.
- Flow through design utilizing existing Wilden pump parts.
- Regulator Shaft controls the flex pattern of the diaphragm extending part life.

Diaphragm vs. Bladder — Equalizer™ utilizes a proven long-lasting Wilden diaphragm. Other manufacturers use a bladder, which inverts leading to premature failure along bead area.

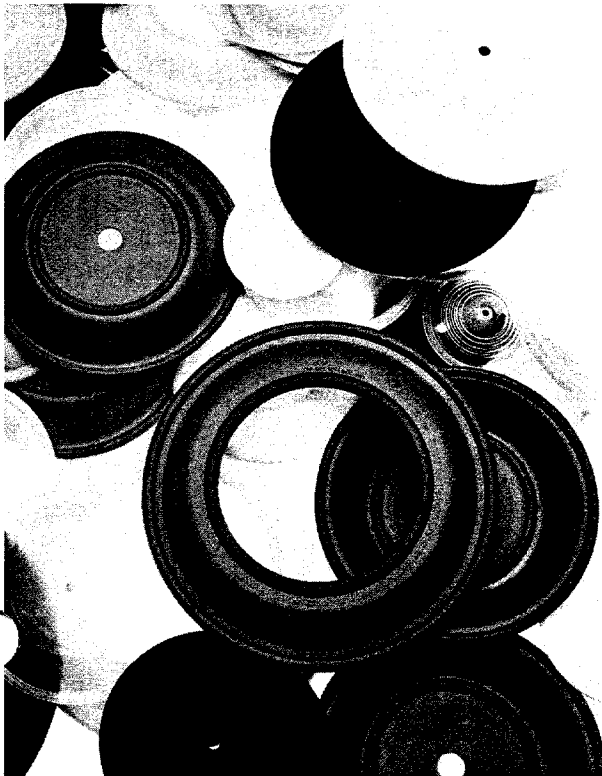
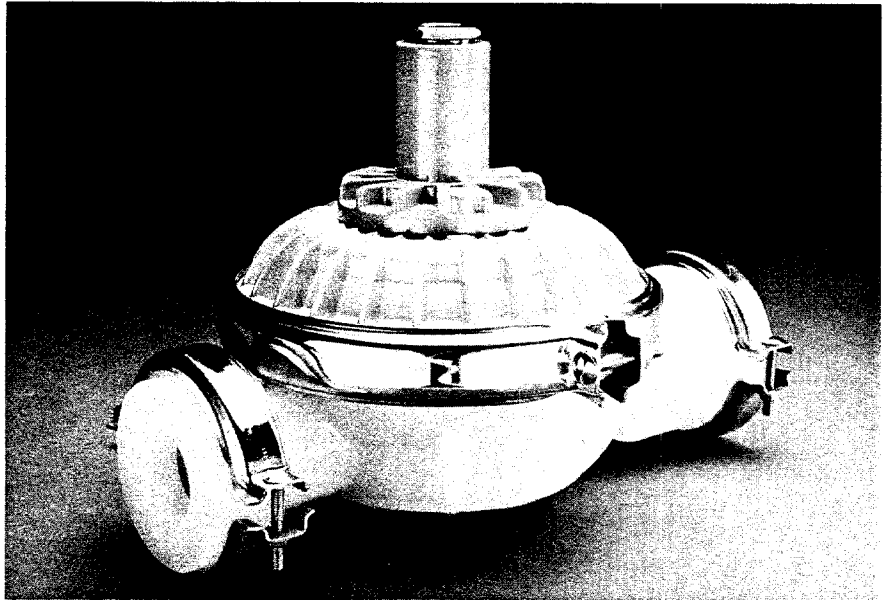

MATERIALS OF CONSTRUCTION:

| | |
|----------------------|------------------------|
| Aluminum | Polypropylene |
| 316 S.S. | PVDF |
| Cast Iron (SD2 only) | Teflon® PFA (SD1 only) |

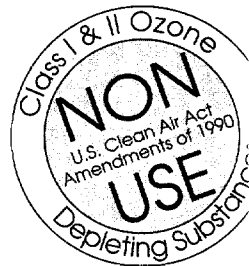

TEMPERATURE LIMITS FOR PLASTICS:

| | |
|---------------|-------------------------------------|
| Polypropylene | +32 F (0 C) to +175 F (79.4 C) |
| PVDF | +10 F (-12.2 C) to +225 F (107.2 C) |
| Teflon® PFA | -20 F (-28.9 C) to +225 F (107.2 C) |

TEMPERATURE LIMITS FOR ELASTOMERS:

| | |
|----------|-------------------------------------|
| Neoprene | 0 F (-17.8 C) to +200 F (93.3 C) |
| Buna-N | +10 F (-12.2 C) to +180 F (82.2 C) |
| Nordel | -60 F (-51.1 C) to +280 F (137.8 C) |
| Viton | -40 F (-40 C) to +350 F (176.7 C) |
| Teflon® | +40 F (+44 C) to +220 F (104.4 C) |

PRESSURE VARIATION BAND

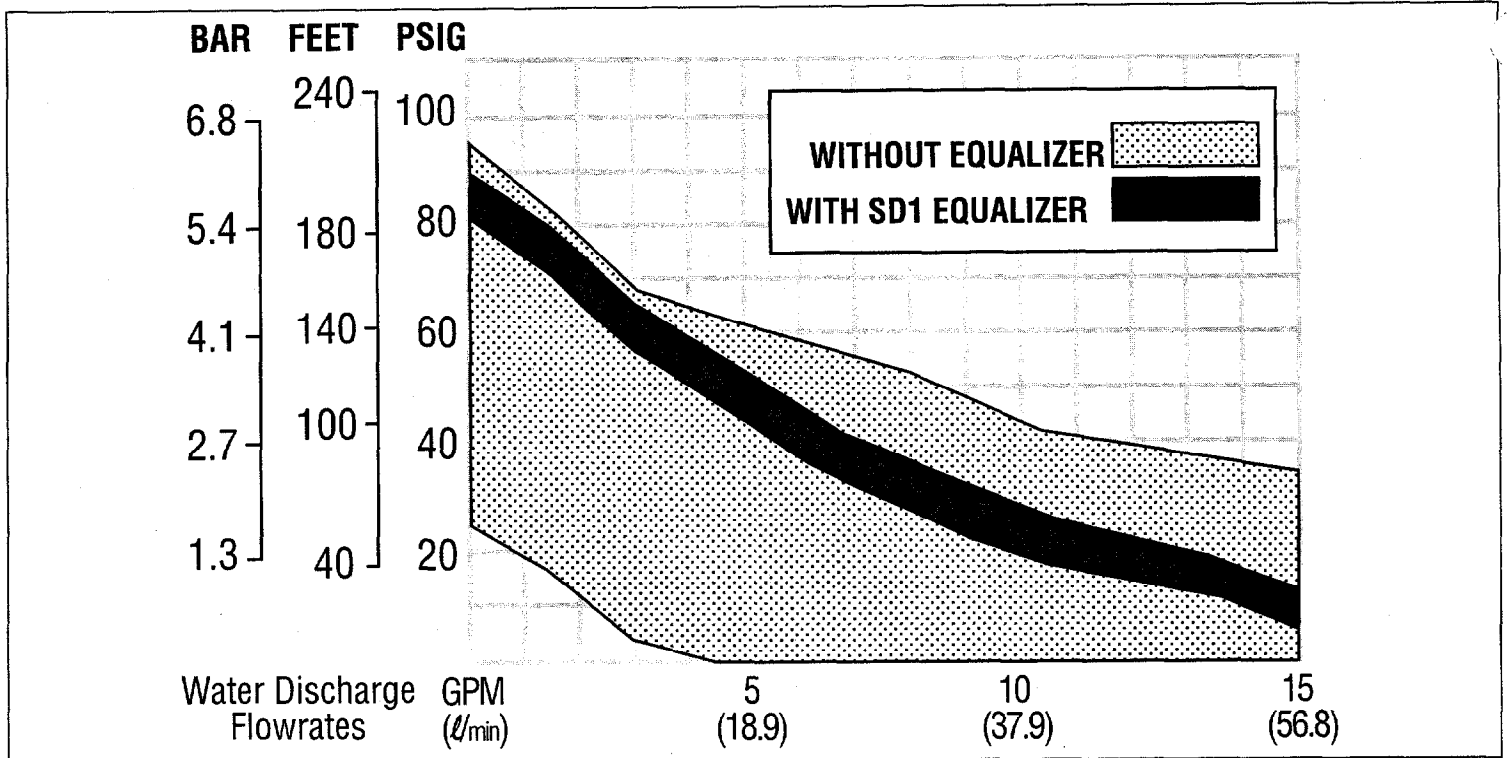

The above curve reflects the discharge pressure variation of a Wilden model M1 compared to an M1 with The Equalizer™ (model SD1) installed. Plotted data points were obtained from an Oscilloscope.

DIMENSIONAL DRAWING MODELS SD1 and SD2

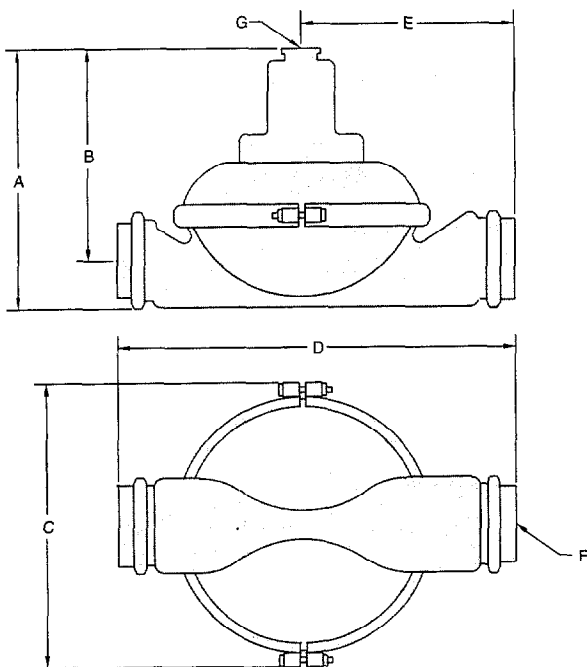

INCHES [mm]

| DIMENSION | SD1 | | SD2 | |
|-----------|---------------|----------------|--------------|--------------|
| | METAL | PLASTIC | METAL | PLASTIC |
| A | 11 [279] | 11 1/2 [292] | 12 [305] | 13 1/2 [343] |
| B | 9 [229] | 9 1/4 [235] | 9 3/4 [248] | 10 1/2 [267] |
| C | 11 3/8 [289] | 11 3/8 [289] | 13 3/4 [349] | 13 3/4 [349] |
| D | 11 5/8 [295] | 15 1/16* [383] | 17 7/8 [454] | 19 3/8 [492] |
| E | 5 13/16 [148] | 7 1/2 [191] | 9 5/8 [244] | 10 3/4 [273] |
| F | 1 NPT | 1 NPT | 2 NPT | 2 NPT |
| G | 1/2 NPT | 1/2 NPT | 1/2 NPT | 1/2 NPT |

*SD1 — Teflon® PFA = 13 1/16"

SD1 (1" INLET/DISCHARGE)

| MATERIAL | SHP. WT. | MATERIAL | SHP. WT. |
|---------------------|----------|-------------|----------|
| Aluminum | 18 lbs. | PVDF | 19 lbs. |
| 316 Stainless Steel | 24 lbs. | Teflon® PFA | 21 lbs. |
| Polypropylene | 18 lbs. | | |

SD2 (2" INLET/DISCHARGE)

| MATERIAL | SHP. WT. | MATERIAL | SHP. WT. |
|---------------------|----------|---------------|----------|
| Aluminum | 27 lbs. | Polypropylene | 28 lbs. |
| Cast Iron | 47 lbs. | PVDF | 34 lbs. |
| 316 Stainless Steel | 44 lbs. | | |

SECTION I – INSTALLATION

The model SD1 has a 1" inlet/discharge. The model SD2 has a 2" inlet/discharge. The Equalizer™ can be installed in either direction. A variety of materials are available to satisfy temperature, chemical compatibility, abrasion and flex concerns. The Equalizer™ installed on the discharge side of the pump minimizes pulsation and protects in-line equipment. It can also be connected on the suction side to prevent water hammer associated with a positive inlet condition.

The Model SD1 is engineered for use with Wilden models M1 and M2. It can also be used with the M4 in applications where the discharge pressure is less than 50 psi. The model SD2 is engineered for use with Wilden models M4 and M8.

Install the Equalizer™ as shown below. The use of flexible connections and a Filter, Regulator,

Lubricator (FRL) will extend parts life. Shut off valves on the suction side of pump and the discharge side of Equalizer™ will enable maintenance personnel to safely service the equipment. To maximize effectiveness install the Equalizer™ as close as possible to the discharge of the pump. **It is important to support the pipe immediately downstream from the Equalizer™.**

Use a tee connector on the pump air supply line and connect the line to the Equalizer™ regulator body. This tee connector should be installed after the FRL. The Equalizer™ consumes very little air, therefore, a 1/4" hose is more than adequate to supply enough air volume. When the air supply to the pump is shut down, the air to the Equalizer™ will be shut off as well.

SUGGESTED INSTALLATION

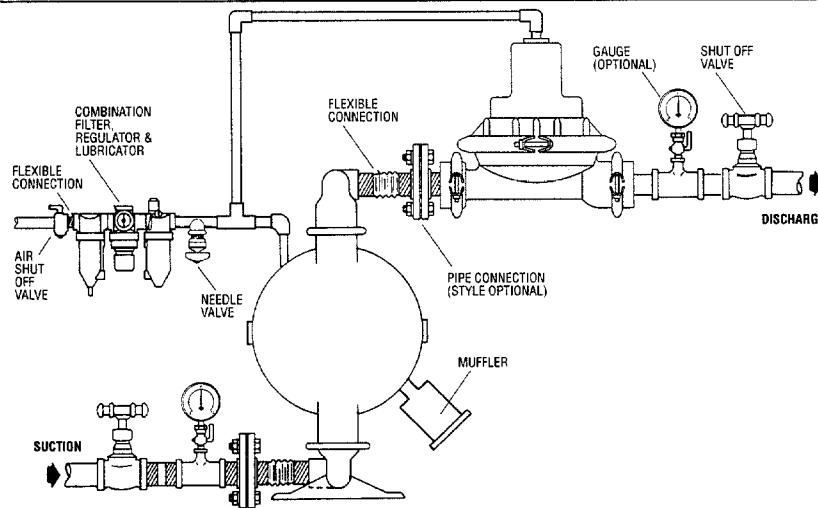

SECTION II – TROUBLESHOOTING

When there is a significant drop in the fluid discharge pressure, there will be a noticeable release of air through a small hole in the air regulator body. This is how the Equalizer™ automatically adjusts itself for optimal suppression. This is a good way of verifying proper operation of the unit. If there is a continuous discharge of air out this hole during steady fluid discharge pressure, the Equalizer™ is not functioning properly and should be inspected. The air regulator body houses three O-rings which may need to be replaced. A few drops of oil in the top of the regulator every 200 hours of operation will significantly extend the life of these O-rings.

Fluid leakage around the clamp band area is normally stopped by tightening the clamp band bolts. If leakage continues, unit should be disassembled and inspected.

Air leakage at the bottom of the air regulator body normally requires the tightening of the three screws located in the air chamber. If leakage continues, the gasket between the air regulator body and air chamber should be replaced.

If air bubbles in fluid discharge line are present, check for diaphragm rupture and tightness of clamp bands.

SECTION III – DIRECTIONS FOR DISASSEMBLY/ASSEMBLY

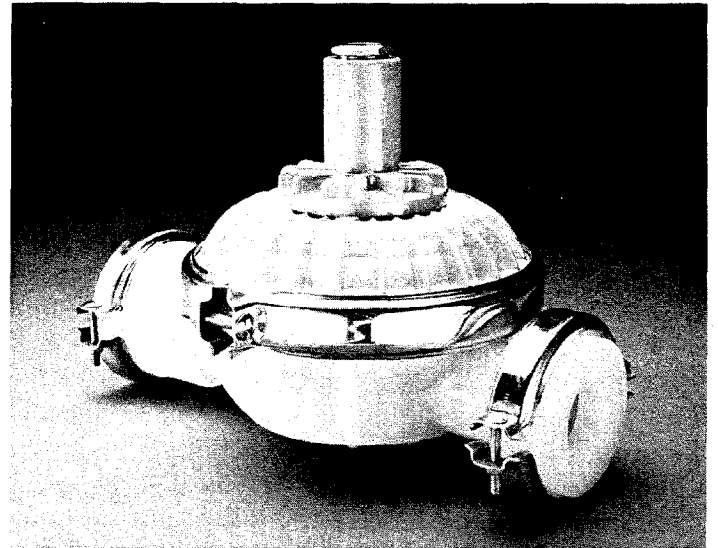
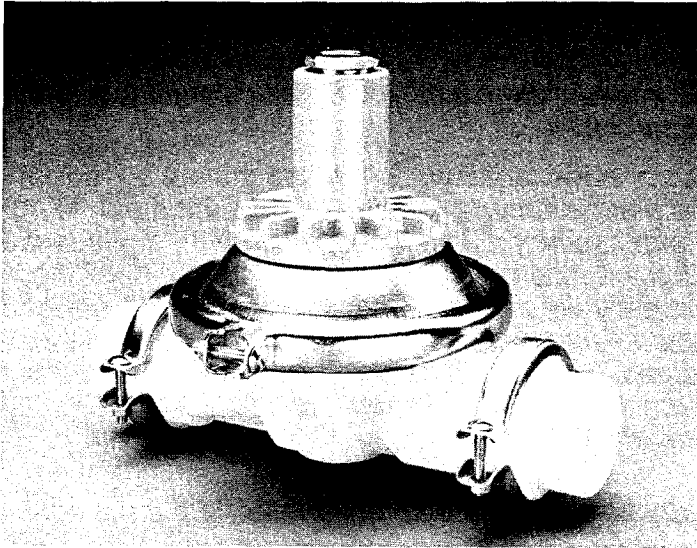

TOOLS REQUIRED

SD1 (1" INLET)

- 3/4" Socket
- 1/2" Socket
- 3/16" Allen Wrench
- O-ring Pick
- Adjustable Wrench
- Pipe Wrench
- 2 Pry Bars (screw drivers)

SD2 (2" INLET)

- 3/4" Socket
- 1/2" Socket
- 11/16" Socket
- 7/32" Allen Wrench
- O-ring Pick
- Adjustable Wrench
- Pipe Wrench
- 2 Pry Bars (screw drivers)

CAUTION: Before any maintenance or repair is attempted, the compressed air line to the Equalizer™ and the pump should be disconnected and all air pressure allowed to bleed from these units. Disconnect all intake, discharge, and air lines. Always wear safety glasses and proper clothing for added protection.

PLEASE READ ALL DIRECTIONS BEFORE STARTING DISASSEMBLY.

The instruction photos depict the SD2 polypropylene Equalizer™. The disassembly/assembly instructions are similar for the SD1 except where noted. To expedite parts ordering, please find an exploded view of the Equalizer™ models at the back of this manual. If you have any questions, please call your local authorized Wilden distributor, or call Wilden Pump & Engineering Co. at (909) 422-1730.

STEP 1

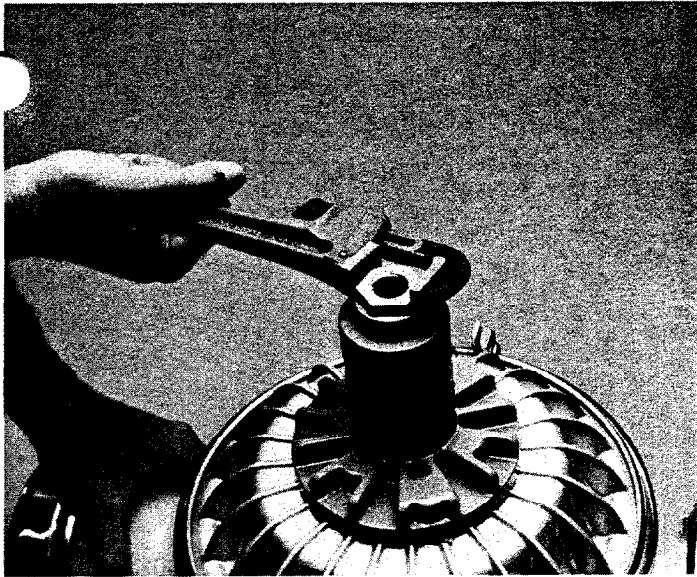

Figure 1

Remove reducer bushing at top of regulator.
(Use pipe wrench.)

STEP 2

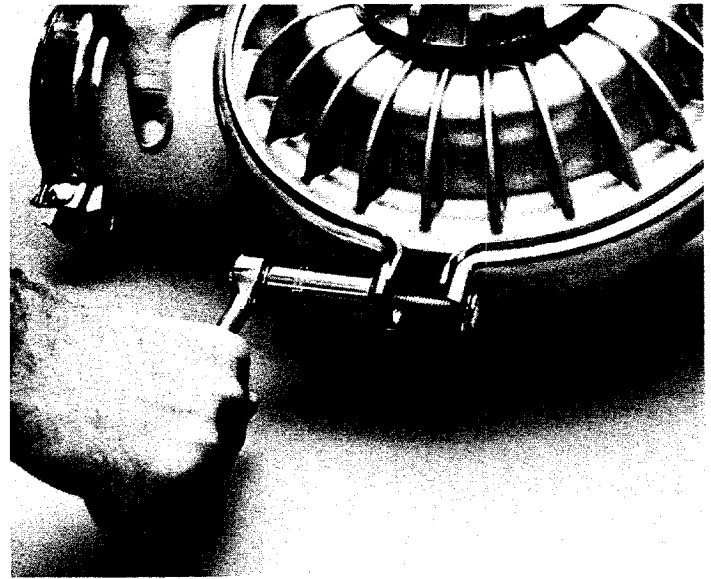

Figure 2

Remove large clamp band.

STEP 3

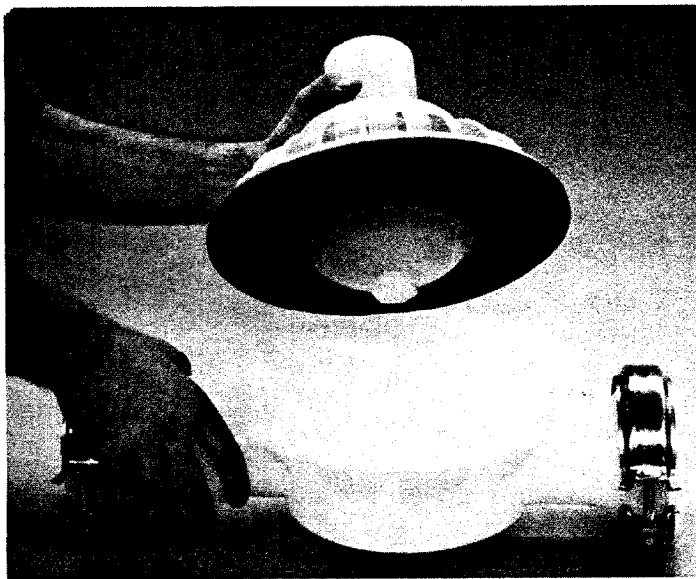

Figure 3

Set liquid chamber aside.

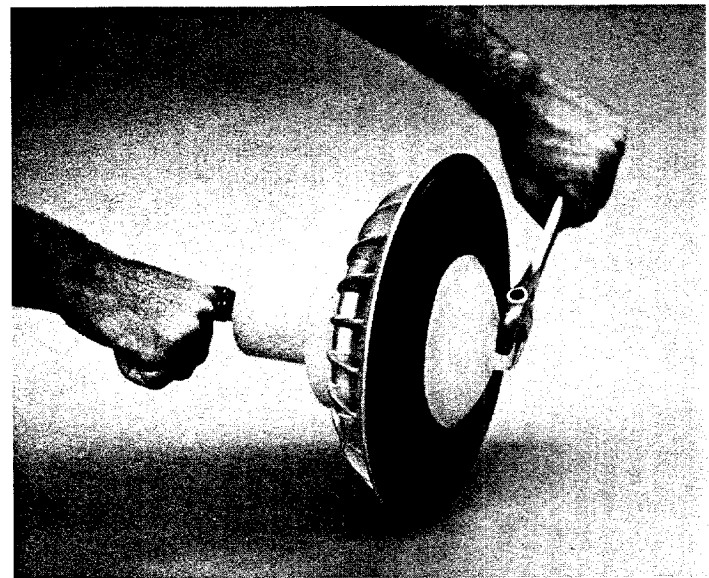

Figure 4

Loosen shaft assembly by using adjustable wrench on outer piston and 3/4" socket on shaft bolt inside air regulator body. Turn counter clockwise. One of two scenarios will occur: outer piston will loosen from shaft, or the shaft bolt will loosen from shaft.

STEP 3 (Cont'd.)

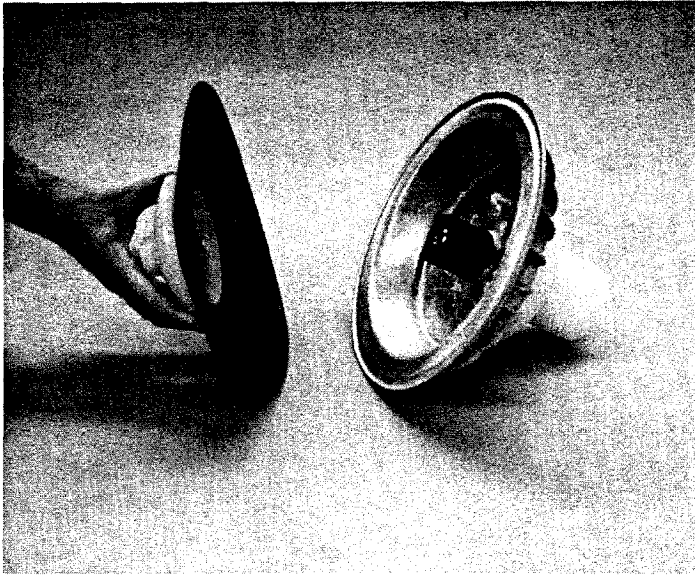

Figure 5

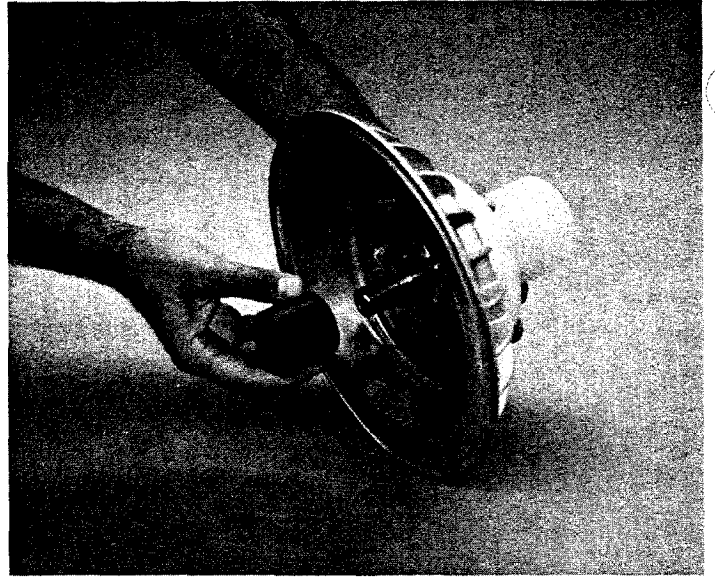

Figure 6

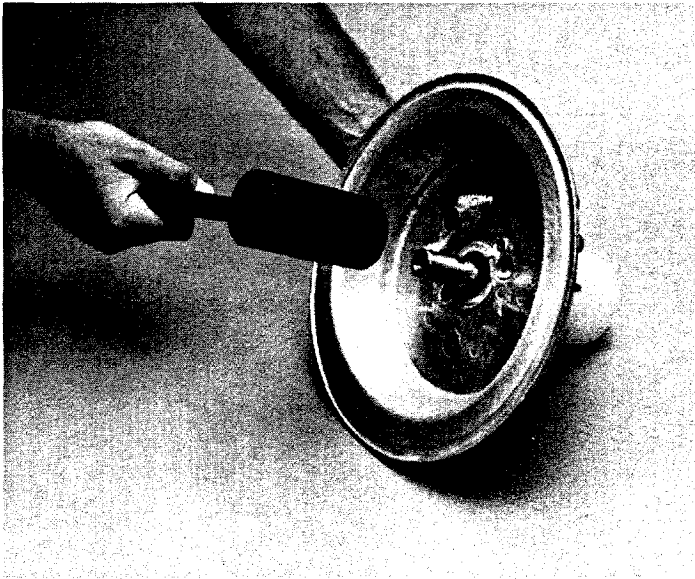

Figure 7

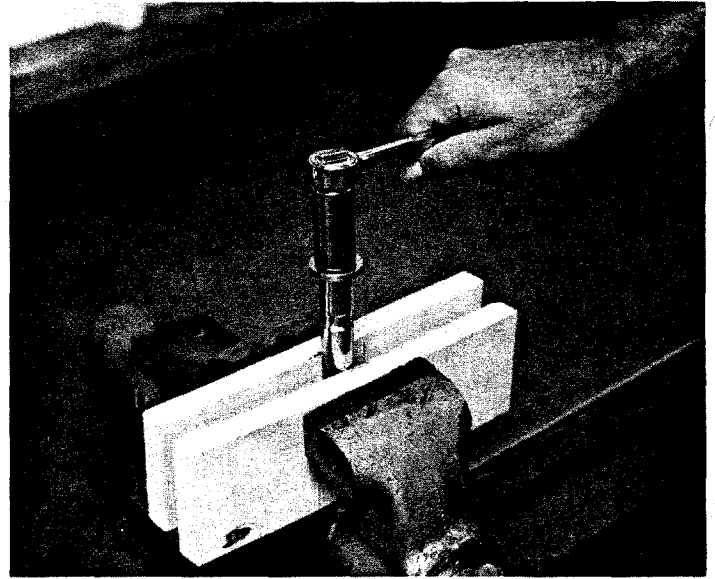

Figure 8

If outer piston loosens, remove outer piston, diaphragm, inner piston, and stop. Then knock shaft through regulator with soft mallet. (See *Figure 7*.) Remove shaft bolt and washer from shaft. Note: Protect the shaft from damage by using wood blocks or soft jaws in vise. (See *Figure 8*.)

STEP 3 (Cont'd.)

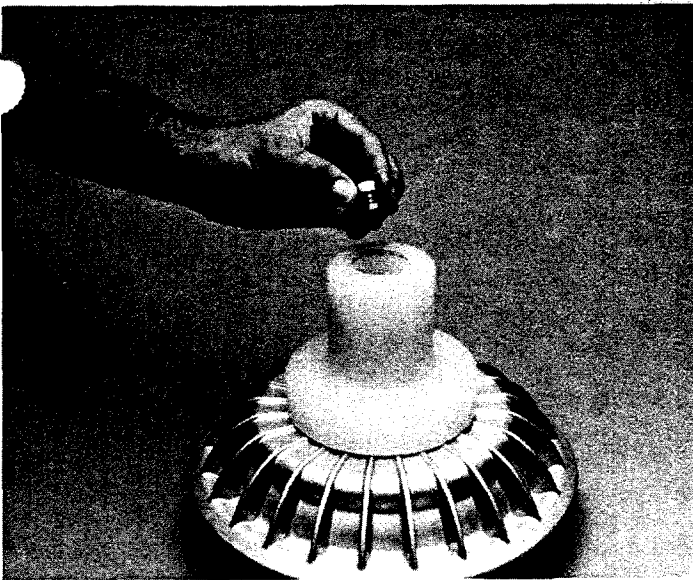

Figure 9

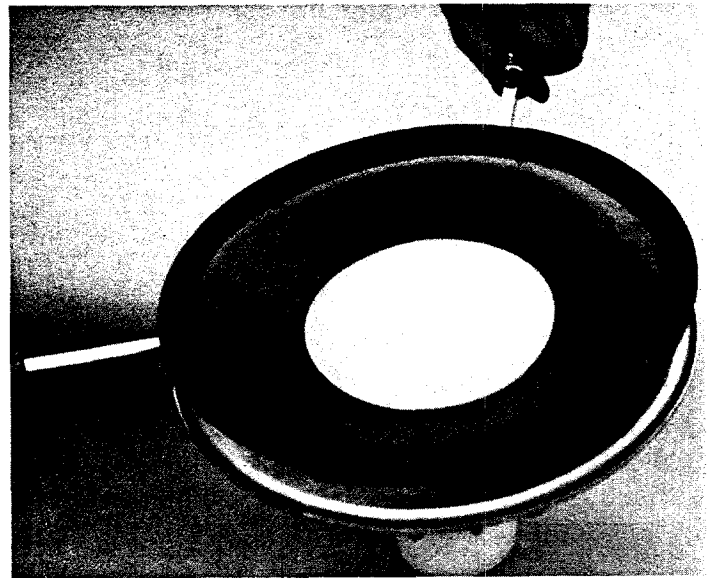

Figure 10

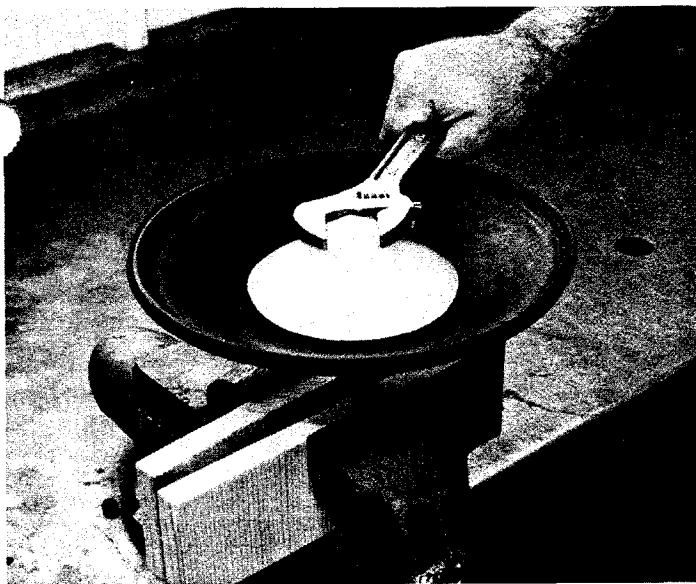

Figure 11

If shaft bolt loosens, remove bolt and washer. (See *Figure 9*.) Turn Equalizer™ upside down and use two pry bars between inner piston and air chamber to pull shaft assembly from regulator. (See *Figure 10*.) Remove Stop. Disassemble shaft assembly by loosening outer piston. Note: Protect the shaft from damage by using wood blocks or soft jaws in vise. (See *Figure 11*.)

STEP 4

Inspect shaft for nicks or abrasion. Small nicks can usually be dressed out. If shaft is chemically attacked or nicks are hindering operation, shaft should be replaced.

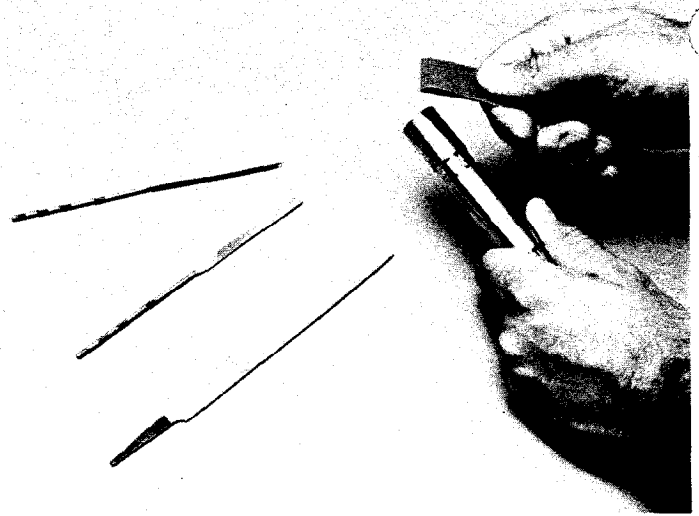

Figure 12

STEP 5

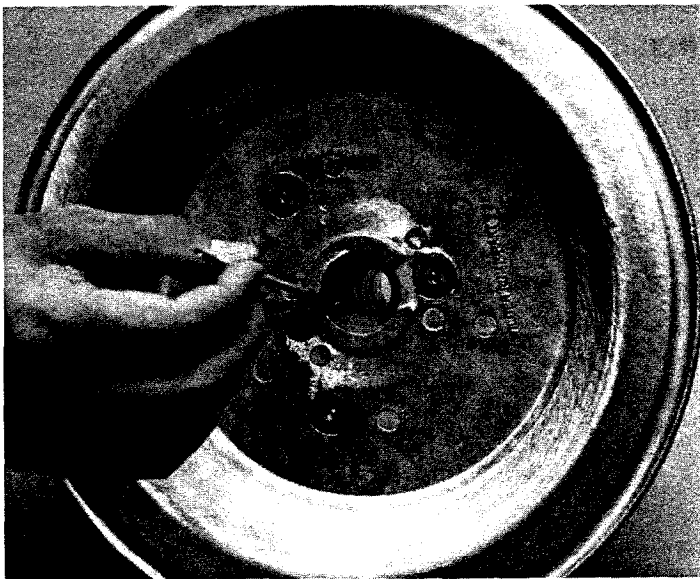

Figure 13

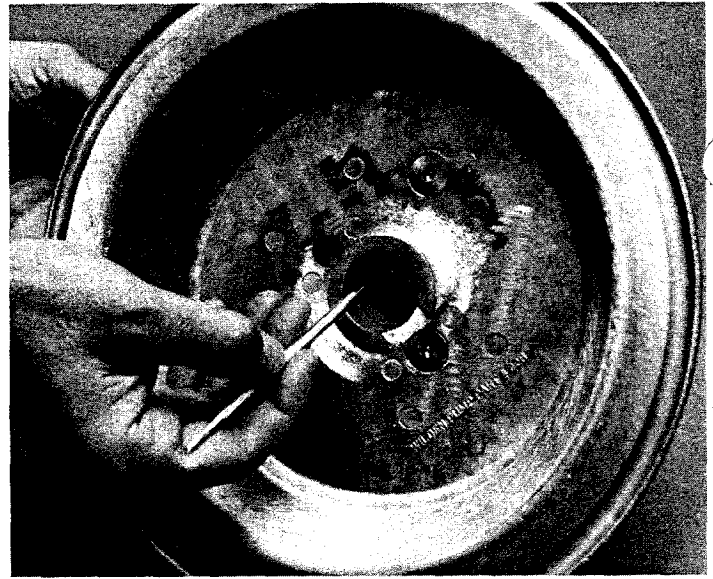

Figure 14

Replace O-rings in air regulator body. This is most easily accomplished by using a tool called an O-ring pick, available through most industrial supply companies. The air regulator body has 5 grooves cut into the inside diameter. There are three O-rings installed in the 1, 3, 5 positions. It is important that these O-rings be installed in the correct grooves so that the Equalizer™ functions properly.

STEP 6

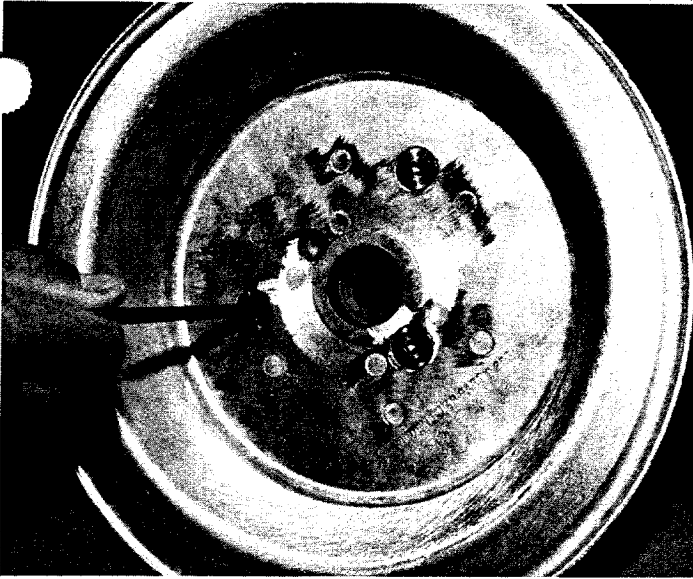

Figure 15

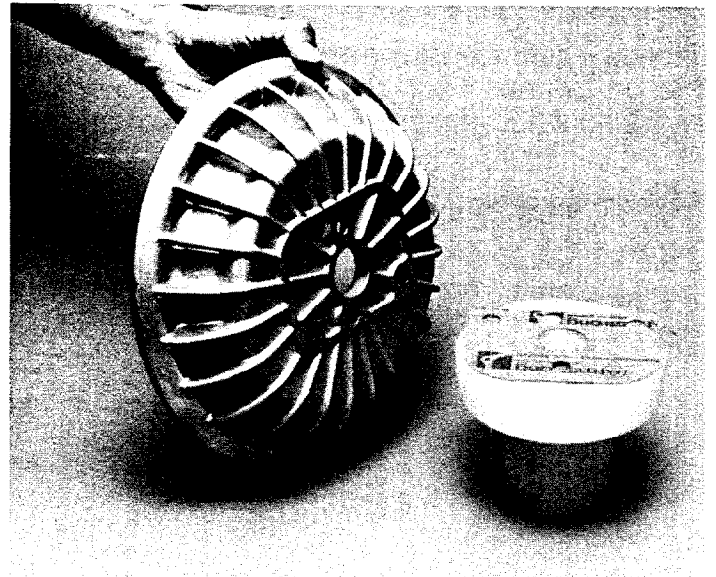

Figure 16

Disassembly of the air chamber from the regulator is needed only in the event of air leakage. Leakage is usually stopped by tightening the allen head bolts. (See *Figure 15.*) If leakage persists, remove air chamber and replace gasket.

STEP 7

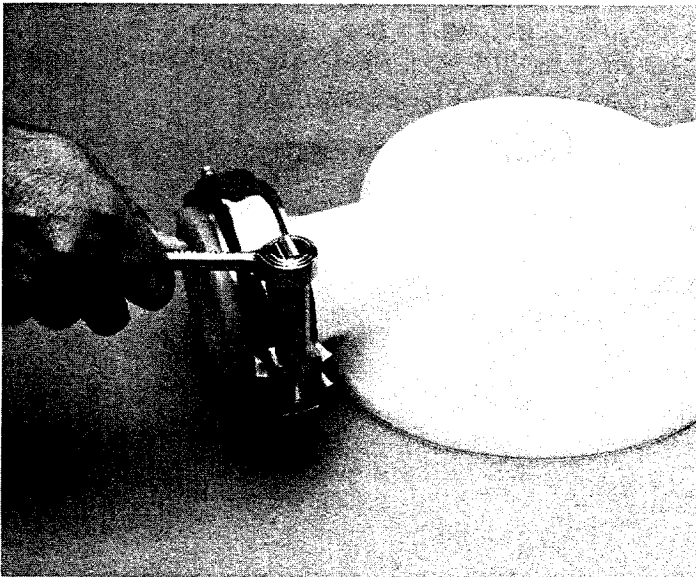

Figure 17

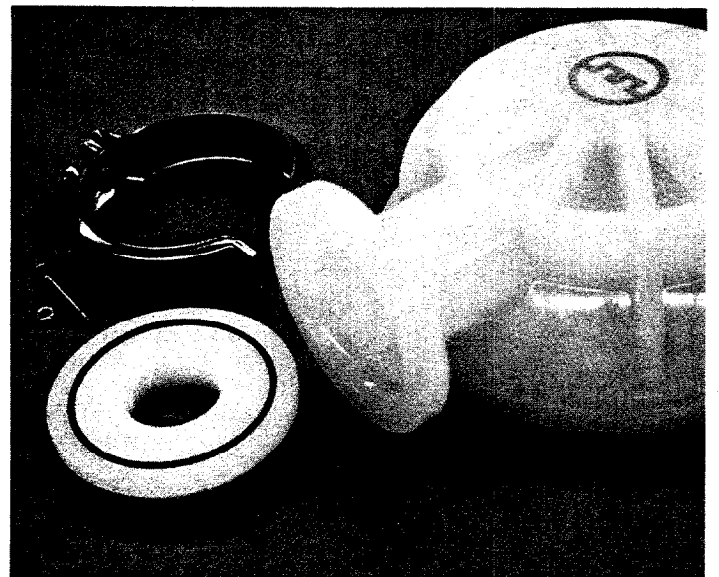

Figure 18

Disassembly of the Surge ends/small clamp band is needed only in the event of leakage. Leakage is usually stopped by tightening the small band bolt. (See *Figure 19.*) If leakage persists, remove surge ends and replace O-rings.

ASSEMBLY

Prior to assembling the Equalizer, please read this page first. Then refer to the disassembly instructions for photos and placement of parts.

Rubber Diaphragm

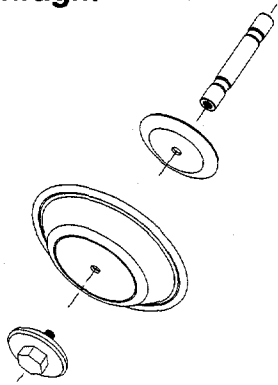

There are two types of diaphragm configurations available for the SD1 and SD2: 1) Rubber diaphragm, and 2) Teflon primary diaphragm with back-up diaphragm. Observe the "This side out" marking on the convex side of the

Teflon® Diaphragm

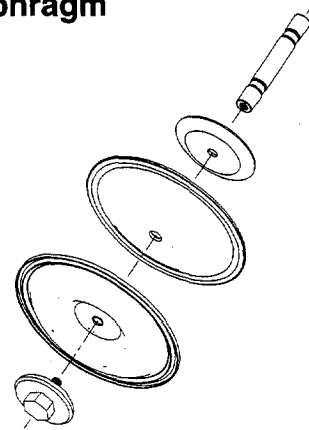

diaphragm. Install the inner piston, diaphragm(s), outer piston plate and stop on shaft. Lubricate the air regulator body O-rings with a 5 wt. arctic grade oil prior to inserting the shaft through the air regulator body.

EQUALIZERS WITH TEFLON® DIAPHRAGMS ONLY

All Equalizers with Teflon® diaphragms require "Gortex" Teflon® gasket material. This is an expanded type of Teflon® which is very strong, but soft. Its use assures a positive seal between

the Teflon® diaphragm outer bead and its corresponding groove in the liquid chamber. This gasket material should be replaced each time the Equalizer™ is disassembled.

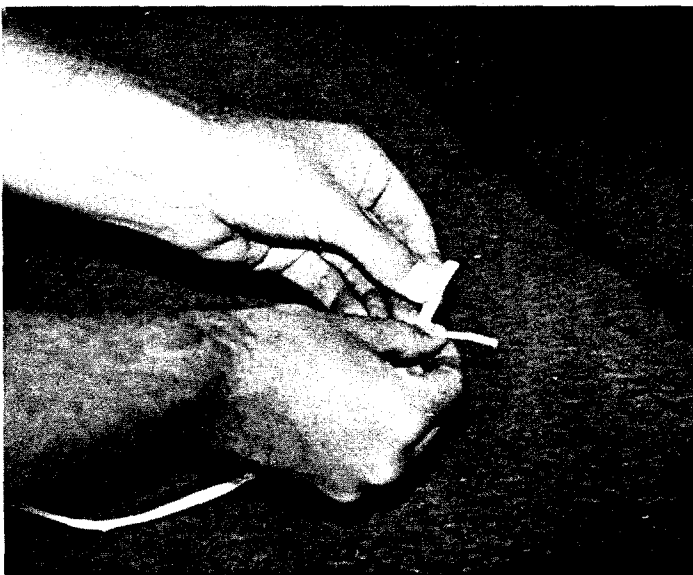

Select a strip of ¼"-wide material and carefully remove the covering from the adhesive strip. Ensure that the adhesive strip remains attached to the gasket material. Starting at any point, place the gasket strip in the center of the

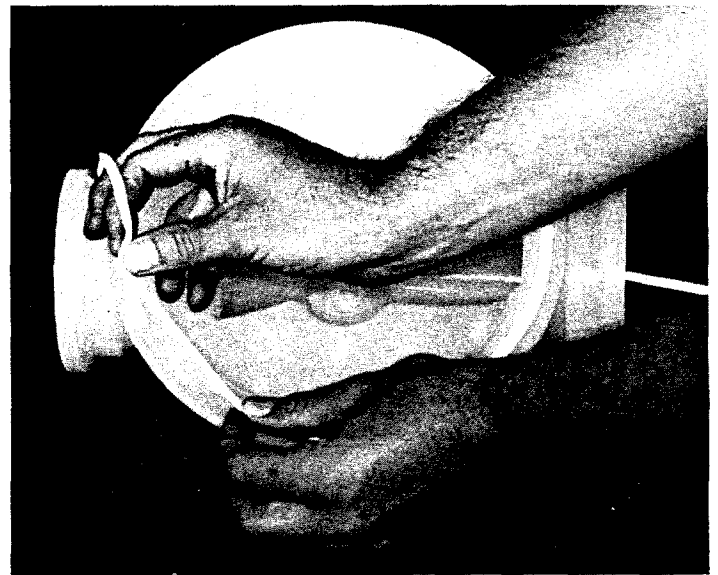

diaphragm bead groove on the chamber and press lightly on the gasket to ensure that adhesive holds it in place during assembly. The ends of the gasket should overlap approximately ½-inch.

EQUALIZER™ SURGE DAMPENER

MODEL NUMBER LEGEND

SD X / (XXX) / XXX / XX / XX

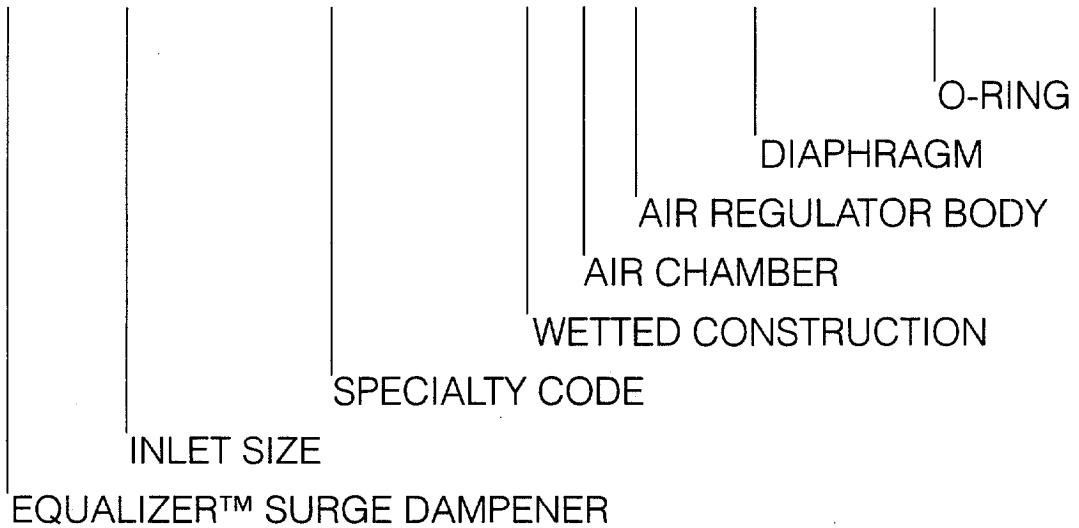

[] Digits included only when necessary.

INLET SIZE

- 1 1 Inch
- 2 2 Inch

WETTED CONSTRUCTION

- A Aluminum
- K PVDF
- P Polypropylene
- T Teflon® PFA (SD1 only)
- S Stainless Steel
- W Cast Iron (SD1 only)

SPECIALTY CODES

- 03 Alloy fitted
- 14 BSP
- 502 w/Teflon® coated hardware
- 508 w/Teflon® coated hardware/BSP

AIR CHAMBER

- A Aluminum
- M Mild Steel (SD1 only)
- S Stainless Steel (SD2 only)
- W Cast Iron (SD2 only)
- C Teflon® Coated

AIR REGULATOR BODY

- P Polypropylene (Glass-filled)

DIAPHRAGM

- BN Buna-N
- ND Nordel
- NE Neoprene
- TF Teflon® TFE
- VT Viton
- WF Wil-Flex™ (SD1 only)

O-RINGS

- BN Buna-N
- TF Teflon®
- TV Teflon® Encap. Viton

THE EQUALIZER™

Exploded View

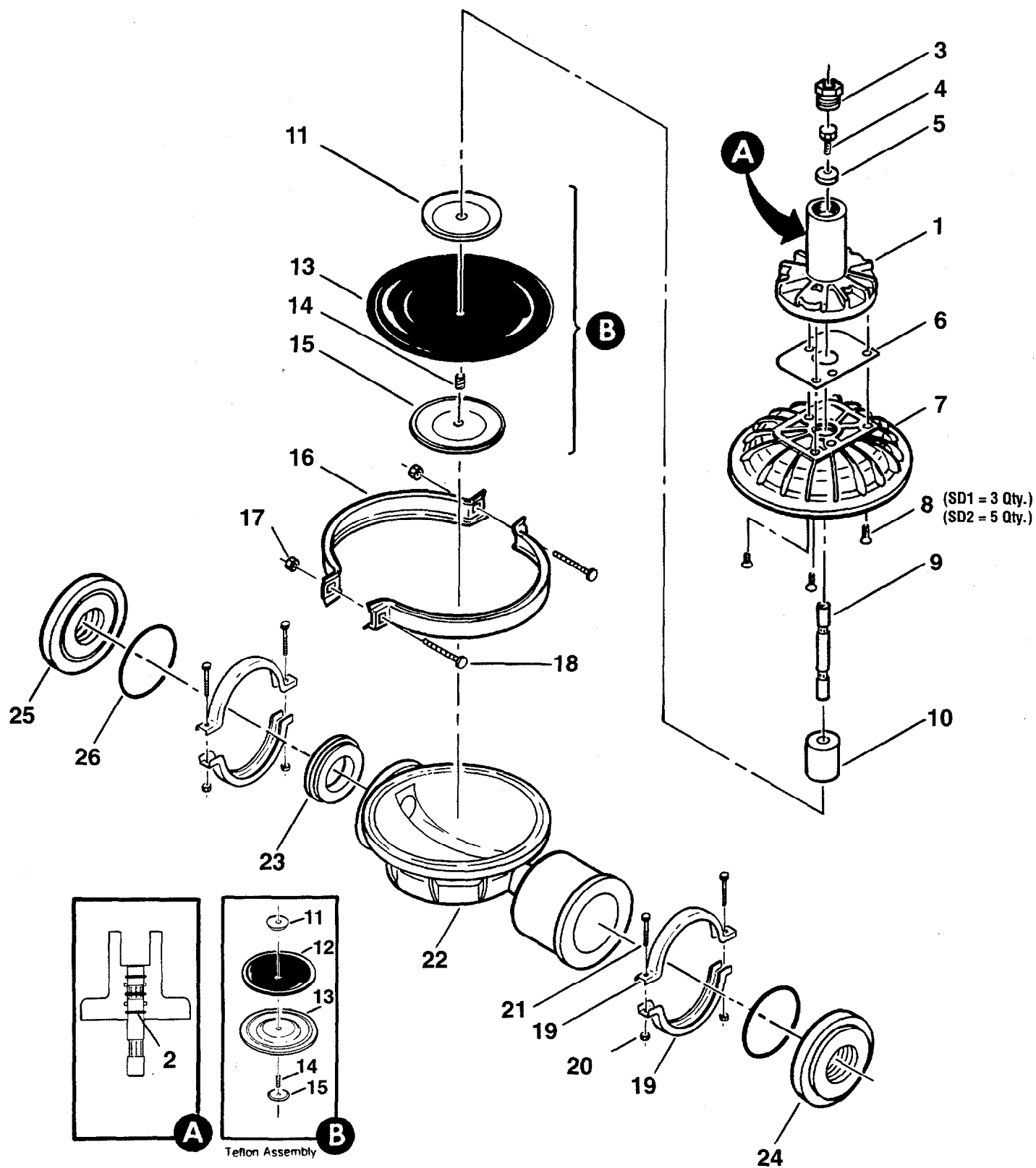

SD1 EQUALIZER™
Aluminum Construction

| ITEM | PART DESCRIPTION | QTY. | SD1-AMP | SD1-03-AMP | SD1-03-AMP-TF |
|------|------------------------------------|------|------------|------------|---------------|
| 1 | Air Regulator Body | 1 | 70-8500-20 | 70-8500-20 | 70-8500-20 |
| 2 | Shaft O-Ring | 3 | 20JH | 20JH | 20JH |
| 3 | Reducer Bushing 1 1/4 x 1/2 NPT | 1 | 70-6950-08 | 70-6950-08 | 70-6950-08 |
| 4 | Shaft Bolt 1/2-20 x 1 | 1 | 61AN | 61AN | 61AN |
| 5 | Flat Washer | 1 | 70-6700-08 | 70-6700-08 | 70-6700-08 |
| 6 | Center Block Gasket | 1 | 04-3520-52 | 04-3520-52 | 04-3520-52 |
| 7 | Air Chamber | 1 | 62 | 62 | 62 |
| 8 | Socket Head Cap Screw 1/4-20 x 3/4 | 3 | 70-6250-03 | 70-6250-03 | 70-6250-03 |
| 9 | Shaft | 1 | T61A | T61A | T61A |
| 10 | Stop | 1 | 70-8800-17 | 70-8800-17 | 70-8800-17 |
| 11 | Inner Piston | 1 | 61C | 61C | TB61C |
| 12 | Back Up Diaphragm | 1 | N/R | N/R | 04-1060-56 |
| 13 | Diaphragm | 1 | * | * | TF63 |
| 14 | Shaft Stud 1/2-20 x 1 1/2 All Thd | 1 | N/R | N/R | T61F |
| 15 | Outer Piston | 1 | 04-4550-01 | 04-4550-01 | T61B |
| 16 | Large Clamp Band Assembly | 1 | 64 | S64 | S64 |
| 17 | Hex Nut 5/16-18 | 2 | 64D | S39C | S39C |
| 18 | Carriage Bolt 5/16-18 x 2 1/4 | 2 | 64C | S64C | S64C |
| 19 | Small Clamp Band Assembly | 2 | 69 | S69 | S69 |
| 20 | Hex Nut 1/4-20 | 4 | 62C | S62C | S62C |
| 21 | Carriage Bolt 1/4-20 x 1 3/4 | 4 | 69B | S94B | S94B |
| 22 | Water Chamber | 1 | 65 | 65 | 65 |
| 23 | Valve Seat | 1 | N/R | N/R | 04-1121-01 |
| 24 | Surge End | 1 | 70-8600-01 | 70-8600-01 | 70-8620-01 |
| 25 | Surge End | 1 | 70-8600-01 | 70-8600-01 | 70-8630-01 |
| 26 | Surge End O-Ring | 2 | * | * | 70T |

SD1 EQUALIZER™
Stainless Steel Construction

| ITEM | PART DESCRIPTION | QTY. | SD1-SMP | SD1-SMP-TF |
|------|------------------------------------|------|------------|------------|
| 1 | Air Regulator Body | 1 | 70-8500-20 | 70-8500-20 |
| 2 | Shaft O-Ring | 3 | 20JH | 20JH |
| 3 | Reducer Bushing 1 1/4 x 1/2 NPT | 1 | 70-6950-08 | 70-6950-08 |
| 4 | Shaft Bolt 1/2-20 x 1 | 1 | 61AN | 61AN |
| 5 | Flat Washer | 1 | 70-6700-08 | 70-6700-08 |
| 6 | Center Block Gasket | 1 | 04-3520-52 | 04-3520-52 |
| 7 | Air Chamber | 1 | 62 | 62 |
| 8 | Socket Head Cap Screw 1/4-20 x 3/4 | 3 | 70-6250-03 | 70-6250-03 |
| 9 | Shaft | 1 | T61A | T61A |
| 10 | Stop | 1 | 70-8800-17 | 70-8800-17 |
| 11 | Inner Piston | 1 | 61C | TB61C |
| 12 | Back Up Diaphragm | 1 | N/R | 04-1060-56 |
| 13 | Diaphragm | 1 | * | TF63 |
| 14 | Shaft Stud 1/2-20 x 1 1/2 All Thd | 1 | T61F | T61F |
| 15 | Outer Piston | 1 | S61B | ST61B |
| 16 | Large Clamp Band Assembly | 1 | S64 | S64 |
| 17 | Hex Nut 5/16-18 | 2 | S39C | S39C |
| 18 | Carriage Bolt 5/16-18 x 2 1/4 | 2 | S64C | S64C |
| 19 | Small Clamp Band Assembly | 2 | S69 | S69 |
| 20 | Hex Nut 1/4-20 | 4 | S62C | S62C |
| 21 | Carriage Bolt 1/4-20 x 1 3/4 | 4 | S94B | S94B |
| 22 | Water Chamber | 1 | S65 | S65 |
| 23 | Valve Seat | 1 | N/R | 04-1121-03 |
| 24 | Surge End | 1 | 70-8600-03 | 70-8620-03 |
| 25 | Surge End | 1 | 70-8600-03 | 70-8630-03 |
| 26 | Surge End O-Ring | 2 | * | 70T |

*Elastomer options listed on page 19.

SD1 EQUALIZER™

Polypropylene and PVDF Construction with Stainless Steel hardware

| ITEM | PART DESCRIPTION | QTY. | SD1-502- | | | |
|------|------------------------------------|------|--------------|-----------------|--------------|-----------------|
| | | | POLY SD1-PMP | POLY SD1-PMP-TF | PVDF SD1-KMP | PVDF SD1-KMP-TF |
| 1 | Air Regulator Body | 1 | 70-8500-20 | 70-8500-20 | 70-8500-20 | 70-8500-20 |
| 2 | Shaft O-Ring | 3 | 20JH | 20JH | 20JH | 20JH |
| 3 | Reducer Bushing 1 1/4 x 1/2 NPT | 1 | 70-6950-08 | 70-6950-08 | 70-6950-08 | 70-6950-08 |
| 4 | Shaft Bolt 1/2-20 x 1 | 1 | 61AN | 61AN | 61AN | 61AN |
| 5 | Flat Washer | 1 | 70-6700-08 | 70-6700-08 | 70-6700-08 | 70-6700-08 |
| 6 | Center Block Gasket | 1 | 04-3520-52 | 04-3520-52 | 04-3520-52 | 04-3520-52 |
| 7 | Air Chamber | 1 | 62 | 62 | 62 | 62 |
| 8 | Socket Head Cap Screw 1/4-20 x 3/4 | 3 | 70-6250-03 | 70-6250-03 | 70-6250-03 | 70-6250-03 |
| 9 | Shaft | 1 | T61A | T61A | T61A | T61A |
| 10 | Stop | 1 | 70-8800-17 | 70-8800-17 | 70-8800-17 | 70-8800-17 |
| 11 | Inner Piston | 1 | 61C | TB61C | 61C | TB61C |
| 12 | Back Up Diaphragm | 1 | N/R | 04-1060-56 | N/R | 04-1060-56 |
| 13 | Diaphragm | 1 | * | TF63 | * | TF63 |
| 14 | Shaft Stud 1/2-20 x 1 1/2 All Thd | 1 | N/R | N/R | N/R | N/R |
| 15 | Outer Piston | 1 | P61B | PT61B | K61B | KT61B |
| 16 | Large Clamp Band Assembly | 1 | MPS64 | MPS64 | MPS64 | MPS64 |
| 17 | Hex Nut 5/16-18 | 2 | S39C | S39C | S39C | S39C |
| 18 | Carriage Bolt 5/16-18 x 2 1/4 | 2 | S64C | S64C | S64C | S64C |
| 19 | Small Clamp Band Assembly | 2 | P69 | P69 | P69 | P69 |
| 20 | Hex Nut 5/16-18 | 4 | S39C | S39C | S39C | S39C |
| 21 | Carriage Bolt 5/16-18 x 1 3/4 | 4 | S32B | S32B | S32B | S32B |
| 22 | Water Chamber | 1 | P65 | P65 | K65 | K65 |
| 23 | Valve Seat | 1 | N/R | N/R | N/R | N/R |
| 24 | Surge End | 1 | 70-8700-20 | 70-8700-20 | 70-8700-21 | 70-8700-21 |
| 25 | Surge End | 1 | 70-8700-20 | 70-8700-20 | 70-8700-21 | 70-8700-21 |
| 26 | Surge End O-Ring | 2 | * | 70-1270-60 | * | 70-1270-60 |

SD1 EQUALIZER™

Polypropylene and PVDF Construction with Teflon®-coated hardware

| ITEM | PART DESCRIPTION | QTY. | SD1-502- | | | |
|------|------------------------------------|------|------------|-------------|------------|-------------|
| | | | POLY PCP | POLY PCP-TF | PVDF KCP | PVDF KCP-TF |
| 1 | Air Regulator Body | 1 | 70-8500-20 | 70-8500-20 | 70-8500-20 | 70-8500-20 |
| 2 | Shaft O-Ring | 3 | 20JH | 20JH | 20JH | 20JH |
| 3 | Reducer Bushing 1 1/4 x 1/2 NPT | 1 | 70-6950-05 | 70-6950-05 | 70-6950-05 | 70-6950-05 |
| 4 | Shaft Bolt 1/2-20 x 1 | 1 | 61AN | 61AN | 61AN | 61AN |
| 5 | Flat Washer | 1 | 70-6700-08 | 70-6700-08 | 70-6700-08 | 70-6700-08 |
| 6 | Center Block Gasket | 1 | 04-3520-52 | 04-3520-52 | 04-3520-52 | 04-3520-52 |
| 7 | Air Chamber | 1 | PC62 | PC62 | PC62 | PC62 |
| 8 | Socket Head Cap Screw 1/4-20 x 3/4 | 3 | 70-6250-03 | 70-6250-03 | 70-6250-03 | 70-6250-03 |
| 9 | Shaft | 1 | T61A | T61A | T61A | T61A |
| 10 | Stop | 1 | 70-8800-17 | 70-8800-17 | 70-8800-17 | 70-8800-17 |
| 11 | Inner Piston | 1 | 61C | TB61C | 61C | TB61C |
| 12 | Back Up Diaphragm | 1 | N/R | 04-1060-56 | N/R | 04-1060-56 |
| 13 | Diaphragm | 1 | * | TF63 | * | TF63 |
| 14 | Shaft Stud 1/2-20 x 1 1/2 All Thd | 1 | N/R | N/R | N/R | N/R |
| 15 | Outer Piston | 1 | P61B | PT61B | K61B | KT61B |
| 16 | Large Clamp Band Assembly | 1 | PCMPS64 | PCMPS64 | PCMPS64 | PCMPS64 |
| 17 | Hex Nut 5/16-18 | 2 | PCS39C | PCS39C | PCS39C | PCS39C |
| 18 | Carriage Bolt 5/16-18 x 2 1/4 | 2 | PCS64C | PCS64C | PCS64C | PCS64C |
| 19 | Small Clamp Band Assembly | 2 | PC69 | PC69 | PC69 | PC69 |
| 20 | Hex Nut 5/16-18 | 4 | PCS39C | PCS39C | PCS39C | PCS39C |
| 21 | Carriage Bolt 5/16-18 x 1 3/4 | 4 | PCS32B | PCS32B | PCS32B | PCS32B |
| 22 | Water Chamber | 1 | P65 | P65 | K65 | K65 |
| 23 | Valve Seat | 1 | N/R | N/R | N/R | N/R |
| 24 | Surge End | 1 | 70-8700-20 | 70-8700-20 | 70-8700-21 | 70-8700-21 |
| 25 | Surge End | 1 | 70-8700-20 | 70-8700-20 | 70-8700-21 | 70-8700-21 |
| 26 | Surge End O-Ring | 2 | * | 70-1270-60 | * | 70-1270-60 |

*Elastomer options listed on page 19.

SD1 EQUALIZER™
Teflon® PFA Construction

| ITEM | PART DESCRIPTION | QTY. | SD1- | | | |
|------|------------------------------------|------|------------|------------|------------|------------|
| | | | TMP-VT | TMP-TF | 502-TMP-VT | 502-TMP-TF |
| 1 | Air Regulator Body | 1 | 70-8500-20 | 70-8500-20 | 70-8500-20 | 70-8500-20 |
| 2 | Shaft O-Ring | 3 | 20JH | 20JH | 20JH | 20JH |
| 3 | Reducer Bushing 1 1/4 x 1/2 NPT | 1 | 70-6950-08 | 70-6950-08 | 70-6950-05 | 70-6950-05 |
| 4 | Shaft Bolt 1/2-20 x 1 | 1 | 61AN | 61AN | 61AN | 61AN |
| 5 | Flat Washer | 1 | 70-6700-08 | 70-6700-08 | 70-6700-08 | 70-6700-08 |
| 6 | Center Block Gasket | 1 | 04-3520-52 | 04-3520-52 | 04-3520-52 | 04-3520-52 |
| 7 | Air Chamber | 1 | 62 | 62 | PC62 | PC62 |
| 8 | Socket Head Cap Screw 1/4-20 x 3/4 | 3 | 70-6250-03 | 70-6250-03 | 70-6250-03 | 70-6250-03 |
| 9 | Shaft | 1 | T61A | T61A | T61A | T61A |
| 10 | Stop | 1 | 70-8800-17 | 70-8800-17 | 70-8800-17 | 70-8800-17 |
| 11 | Inner Piston | 1 | 61C | TB61C | 61C | TB61C |
| 12 | Back Up Diaphragm | 1 | N/R | 04-1060-56 | N/R | 04-1060-56 |
| 13 | Diaphragm | 1 | VT63 | TF63 | VT63 | TF63 |
| 14 | Shaft Stud 1/2-20 x 1 1/2 All Thd | 1 | N/R | N/R | N/R | N/R |
| 15 | Outer Piston | 1 | PFT61B | PFT61B | PFT61B | PFT61B |
| 16 | Large Clamp Band Assembly | 1 | MPS64 | MPS64 | PCMPS64 | PCMPS64 |
| 17 | Hex Nut 5/16-18 | 2 | S39C | S39C | PCS39C | PCS39C |
| 18 | Carriage Bolt 5/16-18 x 2 1/4 | 2 | S64C | S64C | PCS64C | PCS64C |
| 19 | Small Clamp Band Assembly | 2 | P69 | P69 | PC69 | PC69 |
| 20 | Hex Nut 5/16-18 | 4 | S39C | S39C | PCS39C | PCS39C |
| 21 | Carriage Bolt 5/16-18 x 1 3/4 | 4 | S32B | S32B | PCS32B | PCS32B |
| 22 | Water Chamber | 1 | PF65 | PF65 | PF65 | PF65 |
| 23 | Valve Seat | 1 | N/R | N/R | N/R | N/R |
| 24 | Surge End | 1 | 70-8700-22 | 70-8700-22 | 70-8700-22 | 70-8700-22 |
| 25 | Surge End | 1 | 70-8700-22 | 70-8700-22 | 70-8700-22 | 70-8700-22 |
| 26 | Surge End O-Ring | 2 | 70-1270-60 | 70-1270-60 | 70-1270-60 | 70-1270-60 |

SD2 EQUALIZER™

Aluminum and Cast Iron Construction with Standard Hardware

| ITEM | PART DESCRIPTION | QTY. | ALUMINUM SD2-AAP | CAST IRON SD2-WAP | CAST IRON SD2-WWP |
|------|------------------------------------|------|---------------------|----------------------|----------------------|
| 1 | Air Regulator Body | 1 | 70-8500-20 | 70-8500-20 | 70-8500-20 |
| 2 | Shaft O-Ring | 3 | 20JH | 20JH | 20JH |
| 3 | Reducer Bushing 1 1/4 x 1/2 NPT | 1 | 70-6950-08 | 70-6950-08 | 70-6950-08 |
| 4 | Shaft Bolt 1/2-20 x 1 | 1 | 61AN | 61AN | 61AN |
| 5 | Flat Washer | 1 | 70-6700-08 | 70-6700-08 | 70-6700-08 |
| 6 | Center Block Gasket | 1 | 71-3520-30 | 71-3520-30 | 71-3520-30 |
| 7 | Air Chamber for SD2 | 1 | 71-3650-01 | 71-3650-01 | 71-3650-02 |
| 8 | Flat Head Cap Screw 3/8-16 x 1 | 5 | 71-6250-03 | 71-6250-03 | 71-6250-03 |
| 9 | Shaft | 1 | T61A | T61A | T61A |
| 10 | Stop | 1 | 71-8800-17 | 71-8800-17 | 71-8800-17 |
| 11 | Inner Piston | 1 | 61C | 61C | 61C |
| 12 | Back Up Diaphragm | 1 | N/R | N/R | N/R |
| 13 | Diaphragm | 1 | * | * | * |
| 14 | Shaft Stud 1/2-20 x 1 1/2 All Thd | 1 | N/R | 61AN/61D | 61AN/61D |
| 15 | Outer Piston | 1 | 04-4550-01 | 61B | 61B |
| 16 | Large Clamp Band Assembly | 1 | 30 | 30 | 30 |
| 17 | Hex Nut Heavy 3/8-16 | 2 | 30D | 30D | 30D |
| 18 | Hex Head Cap Screw 5/16-18 x 2 3/4 | 2 | 30C | 30C | 30C |
| 19 | Small Clamp Assembly | 2 | 39 | 39 | 39 |
| 20 | Square Nut 5/16-18 | 4 | 39C | 39C | 39C |
| 21 | Hex Head Cap Screw 5/16-18 x 1 3/8 | 4 | 39B | 39B | 39B |
| 22 | Water Chamber | 1 | 35 | W35 | W35 |
| 23 | Valve Seat | 1 | N/R | N/R | N/R |
| 24 | Surge End | 1 | 71-8600-01 | 71-8600-03 | 71-8600-03 |
| 25 | Surge End | 1 | 71-8600-01 | 71-8600-03 | 71-8600-03 |
| 26 | Surge End O-Ring | 2 | * | * | * |

SD2 EQUALIZER™

Cast Iron Construction with Stainless Steel Hardware

| ITEM | PART DESCRIPTION | QTY. | CAST IRON SD2-03-WAP | CAST IRON SD2-03-WWP |
|------|------------------------------------|------|-------------------------|-------------------------|
| 1 | Air Regulator Body | 1 | 70-8500-20 | 70-8500-20 |
| 2 | Shaft O-Ring | 3 | 20JH | 20JH |
| 3 | Reducer Bushing 1 1/4 x 1/2 NPT | 1 | 70-6950-08 | 70-6950-08 |
| 4 | Shaft Bolt 1/2-20 x 1 | 1 | 61AN | 61AN |
| 5 | Flat Washer | 1 | 70-6700-08 | 70-6700-08 |
| 6 | Center Block Gasket | 1 | 71-3520-30 | 71-3520-30 |
| 7 | Air Chamber for SD2 | 1 | 71-3650-01 | 71-3650-02 |
| 8 | Flat Head Cap Screw 3/8-16 x 1 | 5 | 71-6250-03 | 71-6250-03 |
| 9 | Shaft | 1 | T61A | T61A |
| 10 | Stop | 1 | 71-8800-17 | 71-8800-17 |
| 11 | Inner Piston | 1 | 61C | 61C |
| 12 | Back Up Diaphragm | 1 | N/R | N/R |
| 13 | Diaphragm | 1 | * | * |
| 14 | Shaft Stud 1/2-20 x 1 1/2 All Thd | 1 | 61AN/61D | 61AN/61D |
| 15 | Outer Piston | 1 | 61B | 61B |
| 16 | Large Clamp Band Assembly | 1 | S30 | S30 |
| 17 | Hex Nut Heavy 3/8-16 | 2 | S30D | S30D |
| 18 | Hex Head Cap Screw 5/16-18 x 2 3/4 | 2 | S30C | S30C |
| 19 | Small Clamp Band Assembly | 2 | S39 | S39 |
| 20 | Square Nut 5/16-18 | 4 | S39C | S39C |
| 21 | Hex Head Cap Screw 5/16-18 x 1 3/8 | 4 | S39B | S39B |
| 22 | Water Chamber | 1 | W35 | W35 |
| 23 | Valve Seat | 1 | N/R | N/R |
| 24 | Surge End | 1 | 71-8600-03 | 71-8600-03 |
| 25 | Surge End | 1 | 71-8600-03 | 71-8600-03 |
| 26 | Surge End O-Ring | 2 | * | * |

*Elastomer options listed on page 19.

SD2 EQUALIZER™

Aluminum and Stainless Steel Construction with Stainless Steel Hardware

| ITEM | PART DESCRIPTION | QTY. | SD2- | | | |
|------|------------------------------------|------|-----------------------|--------------------|-----------------|-----------------|
| | | | ALUMINUM 03-AAP-TF | ALUMINUM 03-AAP | 316 S.S. SAP | 316 S.S. SSP |
| 1 | Air Regulator Body | 1 | 70-8500-20 | 70-8500-20 | 70-8500-20 | 70-8500-20 |
| 2 | Shaft O-Ring | 3 | 20JH | 20JH | 20JH | 20JH |
| 3 | Reducer Bushing 1 1/4 x 1/2 NPT | 1 | 70-6950-08 | 70-6950-08 | 70-6950-08 | 70-6950-08 |
| 4 | Shaft Bolt 1/2-20 x 1 | 1 | 61AN | 61AN | 61AN | 61AN |
| 5 | Flat Washer | 1 | 70-6700-08 | 70-6700-08 | 70-6700-08 | 70-6700-08 |
| 6 | Center Block Gasket | 1 | 71-3520-30 | 71-3520-30 | 71-3520-30 | 71-3520-30 |
| 7 | Air Chamber for SD2 | 1 | 71-3650-01 | 71-3650-01 | 71-3650-01 | 71-3650-03 |
| 8 | Flat Head Cap Screw 3/8-16 x 1 | 5 | 71-6250-03 | 71-6250-03 | 71-6250-03 | 71-6250-03 |
| 9 | Shaft | 1 | T61A | T61A | T61A | T61A |
| 10 | Stop | 1 | 71-8800-17 | 71-8800-17 | 71-8800-17 | 71-8800-17 |
| 11 | Inner Piston | 1 | T21C | 61C | 61C | 61C |
| 12 | Back Up Diaphragm | 1 | 08-1060-56 | N/R | N/R | N/R |
| 13 | Diaphragm | 1 | TF24 | * | * | * |
| 14 | Shaft Stud 1/2-20 x 1 1/2 All Thd | 1 | T21F | N/R | T61F | T61F |
| 15 | Outer Piston | 1 | T21B | 04-4550-01 | S61B | S61B |
| 16 | Large Clamp Band Assembly | 1 | S30 | S30 | S30 | S30 |
| 17 | Hex Nut Heavy 3/8-16 | 2 | S30D | S30D | S30D | S30D |
| 18 | Hex Head Cap Screw 3/8-16 x 2 3/4 | 2 | S30C | S30C | S30C | S30C |
| 19 | Small Clamp Band Assembly | 2 | S39 | S39 | S39 | S39 |
| 20 | Hex Nut 5/16-18 | 4 | S39C | S39C | S39C | S39C |
| 21 | Hex Head Cap Screw 5/16-18 x 1 3/8 | 4 | S39B | S39B | S39B | S39B |
| 22 | Water Chamber | 1 | 35 | 35 | S35 | S35 |
| 23 | Valve Seat | 1 | 08-1121-01 | N/R | N/R | N/R |
| 24 | Surge End | 1 | 71-8720-01 | 71-8600-01 | 71-8600-03 | 71-8600-03 |
| 25 | Surge End | 1 | 71-8730-01 | 71-8600-01 | 71-8600-03 | 70-8600-03 |
| 26 | Surge End O-Ring | 2 | 40T | * | * | * |

SD2 EQUALIZER™

Stainless Steel and Cast Iron Construction with Stainless Steel Hardware

| ITEM | PART DESCRIPTION | QTY. | SD2- | | | |
|------|------------------------------------|------|--------------------|--------------------|------------------------|------------------------|
| | | | 316 S.S. SAP-TF | 316 S.S. SSP-TF | CAST IRON 03-WAP-TF | CAST IRON 03-WWP-TF |
| 1 | Air Regulator Body | 1 | 70-8500-20 | 70-8500-20 | 70-8500-20 | 70-8500-20 |
| 2 | Shaft O-Ring | 3 | 20JH | 20JH | 20JH | 20JH |
| 3 | Reducer Bushing 1 1/4 x 1/2 NPT | 1 | 70-6950-08 | 70-6950-08 | 70-6950-08 | 70-6950-08 |
| 4 | Shaft Bolt 1/2-20 x 1 | 1 | 61AN | 61AN | 61AN | 61AN |
| 5 | Flat Washer | 1 | 70-6700-08 | 70-6700-08 | 70-6700-08 | 70-6700-08 |
| 6 | Center Block Gasket | 1 | 71-3520-30 | 71-3520-30 | 71-3520-30 | 71-3520-30 |
| 7 | Air Chamber for SD2 | 1 | 71-3650-01 | 71-3650-03 | 71-3650-01 | 71-3650-02 |
| 8 | Flat Head Cap Screw 3/8-16 x 1 | 5 | 71-6250-03 | 71-6250-03 | 71-6250-03 | 71-6250-03 |
| 9 | Shaft | 1 | T61A | T61A | T61A | T61A |
| 10 | Stop | 1 | 71-8800-17 | 71-8800-17 | 71-8800-17 | 71-8800-17 |
| 11 | Inner Piston | 1 | T21C | T21C | T21C | T21C |
| 12 | Back Up Diaphragm | 1 | 08-1060-56 | 08-1060-56 | 08-1060-56 | 08-1060-56 |
| 13 | Diaphragm | 1 | TF24 | TF24 | TF24 | TF24 |
| 14 | Shaft Stud 1/2-20 x 1 1/2 All Thd | 1 | T21F | T21F | T21F | T21F |
| 15 | Outer Piston | 1 | ST21B | ST21B | ST21B | ST21B |
| 16 | Large Clamp Band Assembly | 1 | S30 | S30 | S30 | S30 |
| 17 | Hex Nut Heavy 3/8-16 | 2 | S30D | S30D | S30D | S30D |
| 18 | Hex Head Cap Screw 3/8-16 x 2 3/4 | 2 | S30C | S30C | S30C | S30C |
| 19 | Small Clamp Band Assembly | 2 | S39 | S39 | S39 | S39 |
| 20 | Hex Nut 5/16-18 | 4 | S39C | S39C | S39C | S39C |
| 21 | Hex Head Cap Screw 5/16-18 x 1 3/8 | 4 | S39B | S39B | S39B | S39B |
| 22 | Water Chamber | 1 | S35 | S35 | W35 | W35 |
| 23 | Valve Seat | 1 | 08-1121-03 | 08-1121-03 | 08-1121-08 | 08-1121-08 |
| 24 | Surge End | 1 | 71-8720-03 | 70-8720-03 | 71-8720-03 | 71-8720-03 |
| 25 | Surge End | 1 | 71-8730-03 | 71-8730-03 | 71-8730-03 | 71-8730-03 |
| 26 | Surge End O-Ring | 2 | 40T | 40T | 40T | 40T |

*Elastomer options listed on page 19.

SD2 EQUALIZER™**Polypropylene and PVDF Construction with Stainless Steel Hardware**

| ITEM | PART DESCRIPTION | QTY. | SD2- | | | |
|------|------------------------------------|------|------------|-------------|------------|-------------|
| | | | POLY PAP | POLY PAP-TF | PVDF KAP | PVDF KAP-TF |
| 1 | Air Regulator Body | 1 | 70-8500-20 | 70-8500-20 | 70-8500-20 | 70-8500-20 |
| 2 | Shaft O-Ring | 3 | 20JH | 20JH | 20JH | 20JH |
| 3 | Reducer Bushing 1 1/4 x 1/2 NPT | 1 | 70-6950-08 | 70-6950-08 | 70-6950-08 | 70-6950-08 |
| 4 | Shaft Bolt 1/2-20 x 1 | 1 | 61AN | 61AN | 61AN | 61AN |
| 5 | Flat Washer | 1 | 70-6700-08 | 70-6700-08 | 70-6700-08 | 70-6700-08 |
| 6 | Center Block Gasket | 1 | 71-3520-30 | 71-3520-30 | 71-3520-30 | 71-3520-30 |
| 7 | Air Chamber for SD2 | 1 | 71-3650-01 | 71-3650-01 | 71-3650-01 | 71-3650-01 |
| 8 | Flat Head Cap Screw 3/8-16 x 1 | 5 | 71-6250-03 | 71-6250-03 | 71-6250-03 | 71-6250-03 |
| 9 | Shaft | 1 | T61A | T61A | T61A | T61A |
| 10 | Stop | 1 | 71-8800-17 | 71-8800-17 | 71-8800-17 | 71-8800-17 |
| 11 | Inner Piston | 1 | 61C | T21C | 61C | T21C |
| 12 | Back Up Diaphragm | 1 | N/R | 08-1060-56 | N/R | 08-1060-56 |
| 13 | Diaphragm | 1 | * | TF24 | * | TF24 |
| 14 | Shaft Stud 1/2-20 x 1 1/2 All Thd | 1 | N/R | N/R | N/R | N/R |
| 15 | Outer Piston | 1 | P61B | KT21B | K61B | KT21B |
| 16 | Large Clamp Band Assembly | 1 | P30 | P30 | P30 | P30 |
| 17 | Hex Nut Heavy 3/8-16 | 2 | S30D | S30D | S30D | S30D |
| 18 | Carriage Bolt 3/8-16 x 2 1/2 | 2 | P30C | P30C | P30C | P30C |
| 19 | Small Clamp Band Assembly | 2 | P39 | P39 | P39 | P39 |
| 20 | Hex Nut 5/16-89 | 4 | S39C | S39C | S39C | S39C |
| 21 | Hex Head Cap Screw 5/16-18 x 2 1/4 | 4 | S64C | S64C | S64C | S64C |
| 22 | Water Chamber | 1 | P35 | P35 | K35 | K35 |
| 23 | Valve Seat | 1 | N/R | N/R | N/R | N/R |
| 24 | Surge End | 1 | 71-8700-20 | 71-8700-20 | 71-8700-21 | 71-8700-21 |
| 25 | Surge End | 1 | 71-8710-20 | 71-8710-20 | 71-8710-21 | 71-8710-21 |
| 26 | Surge End O-Ring | 2 | * | 71-1270-60 | * | 71-1270-60 |

SD2 EQUALIZER™**Polypropylene and PVDF Construction with Teflon®-coated Hardware and Air Chambers**

| ITEM | PART DESCRIPTION | QTY. | SD2-502 | | | |
|------|------------------------------------|------|------------|-------------|------------|-------------|
| | | | POLY PCP | POLY PCP-TF | PVDF KCP | PVDF KCP-TF |
| 1 | Air Regulator Body | 1 | 70-8500-20 | 70-8500-20 | 70-8500-20 | 70-8500-20 |
| 2 | Shaft O-Ring | 3 | 20JH | 20JH | 20JH | 20JH |
| 3 | Reducer Bushing 1 1/4 x 1/2 NPT | 1 | 70-6950-05 | 70-6950-05 | 70-6950-05 | 70-6950-05 |
| 4 | Shaft Bolt 1/2-20 x 1 | 1 | 61AN | 61AN | 61AN | 61AN |
| 5 | Flat Washer | 1 | 70-6700-08 | 70-6700-08 | 70-6700-08 | 70-6700-08 |
| 6 | Center Block Gasket | 1 | 71-3520-30 | 71-3520-30 | 71-3520-30 | 71-3520-30 |
| 7 | Air Chamber for SD2 | 1 | 71-3650-05 | 71-3650-05 | 71-3650-05 | 71-3650-05 |
| 8 | Flat Head Cap Screw 3/8-16 x 1 | 5 | 71-6250-03 | 71-6250-03 | 71-6250-03 | 71-6250-03 |
| 9 | Shaft | 1 | T61A | T61A | T61A | T61A |
| 10 | Stop | 1 | 71-8800-17 | 71-8800-17 | 71-8800-17 | 71-8800-17 |
| 11 | Inner Piston | 1 | 61C | T21C | 61C | T21C |
| 12 | Back Up Diaphragm | 1 | N/R | 08-1060-56 | N/R | 08-1060-56 |
| 13 | Diaphragm | 1 | * | TF24 | * | TF24 |
| 14 | Shaft Stud 1/2-20 x 1 1/2 All Thd | 1 | N/R | N/R | N/R | N/R |
| 15 | Outer Piston | 1 | P61B | KT21B | K61B | KT21B |
| 16 | Large Clamp Band Assembly | 1 | PC30 | PC30 | PC30 | PC30 |
| 17 | Hex Nut Heavy 3/8-16 | 2 | PCS30D | PCS30D | PCS30D | PCS30D |
| 18 | Carriage Bolt 3/8-16 x 2 1/2 | 2 | PC30C | PC30C | PC30C | PC30C |
| 19 | Small Clamp Band Assembly | 2 | PC39 | PC39 | PC39 | PC39 |
| 20 | Hex Nut 5/16-89 | 4 | PCS39C | PCS39C | PCS39C | PCS39C |
| 21 | Hex Head Cap Screw 5/16-18 x 2 1/4 | 4 | PCS64C | PCS64C | PCS64C | PCS64C |
| 22 | Water Chamber | 1 | P35 | P35 | K35 | K35 |
| 23 | Valve Seat | 1 | N/R | N/R | N/R | N/R |
| 24 | Surge End | 1 | 71-8700-20 | 71-8700-20 | 71-8700-21 | 71-8700-21 |
| 25 | Surge End | 1 | 71-8710-20 | 71-8710-20 | 71-8710-21 | 71-8710-21 |
| 26 | Surge End O-Ring | 2 | * | 71-1270-60 | * | 71-1270-60 |

*Elastomer options listed on page 19.

ELASTOMER OPTIONS

ELASTOMERS FOR METAL SD1 EQUALIZERS

| | DIAPHRAGM | BACK-UP DIAPHRAGM | O-RINGS |
|-----------|-----------|-------------------|------------|
| Teflon® | TF63 | NA | 70T |
| Buna-N | BN63 | NA | 70-1280-52 |
| Neoprene | 63 | NA | NA |
| Nordel | ND63 | NA | NA |
| Viton | VT63 | NA | NA |
| Saniflex™ | NA | 04-1060-56 | NA |

ELASTOMERS FOR PLASTIC SD1 EQUALIZERS

| | DIAPHRAGM | BACK-UP DIAPHRAGM | O-RINGS |
|----------------------------|-----------|-------------------|------------|
| Teflon® TFE | TF63 | NA | NA |
| Teflon® Encapsulated Viton | NA | NA | 70-1270-60 |
| Buna-N | BN63 | NA | 70-1270-52 |
| Neoprene | 63 | NA | NA |
| Nordel | ND63 | NA | NA |
| Viton | VT63 | NA | NA |
| Saniflex™ | NA | 04-1060-56 | NA |

ELASTOMERS FOR METAL SD2 EQUALIZERS

| | DIAPHRAGM | BACK-UP DIAPHRAGM | O-RINGS |
|-----------|-----------|-------------------|------------|
| Teflon® | TF24 | NA | 40T |
| Buna-N | BN26 | NA | 71-1280-52 |
| Neoprene | 26 | NA | NA |
| Nordel | ND26 | NA | NA |
| Viton | VT26 | NA | NA |
| Saniflex™ | NA | 08-1060-56 | NA |

ELASTOMERS FOR PLASTIC SD2 EQUALIZERS

| | DIAPHRAGM | BACK-UP DIAPHRAGM | O-RINGS |
|----------------------------|-----------|-------------------|------------|
| Teflon® | TF24 | NA | NA |
| Teflon® Encapsulated Viton | NA | NA | 71-1270-60 |
| Buna-N | BN26 | NA | 71-1270-52 |
| Neoprene | 26 | NA | NA |
| Nordel | ND26 | NA | NA |
| Viton | VT26 | NA | NA |
| Saniflex™ | NA | 08-1060-56 | NA |

TORQUE SPECIFICATIONS

TORQUE SPECIFICATIONS FOR METAL SD1 EQUALIZERS

| ITEM # | DESCRIPTION OF PART | MAXIMUM TORQUE |
|--------|----------------------------|-------------------------|
| 1 | Air Regulator Body | 11 ft.-lbs. [14.9 m-N] |
| 2 | Shaft Assembly | 33 ft.-lbs. [44.7 m-N] |
| 3 | Small Clamp Band | 30 in.-lbs. [3.4 m-N] |
| 4 | Large Clamp Band — Rubber | 100 in.-lbs. [11.3 m-N] |
| 5 | Large Clamp Band — Teflon® | 120 in.-lbs. [13.6 m-N] |

TORQUE SPECIFICATIONS FOR PLASTIC SD1 EQUALIZERS

| ITEM # | DESCRIPTION OF PART | MAXIMUM TORQUE |
|--------|---------------------|-------------------------|
| 1 | Air Regulator Body | 11 ft.-lbs. [14.9 m-N] |
| 2 | Shaft Assembly | 38 ft.-lbs. [51.5 m-N] |
| 3 | Small Clamp Bands | 85 in.-lbs. [9.6 m-N] |
| 4 | Large Clamp Bands | 165 in.-lbs. [18.6 m-N] |

TORQUE SPECIFICATIONS FOR METAL SD2 EQUALIZERS

| ITEM # | DESCRIPTION OF PART | MAXIMUM TORQUE |
|--------|--------------------------|------------------------|
| 1 | Air Regulator Body | 25 in.-lbs. [2.8 m-N] |
| 2 | Shaft Assembly — Rubber | 33 ft.-lbs. [44.7 m-N] |
| 3 | Shaft Assembly — Teflon® | 58 ft.-lbs. [78.6 m-N] |
| 4 | Small Clamp Band | 27 in.-lbs. [3.0 m-N] |
| 5 | Small Clamp Band | 58 in.-lbs. [6.6 m-N] |
| 6 | Large Clamp Band | 28 ft.-lbs. [38.0 m-N] |

TORQUE SPECIFICATIONS FOR PLASTIC SD2 EQUALIZERS

| ITEM # | DESCRIPTION OF PART | MAXIMUM TORQUE |
|--------|--------------------------|------------------------|
| 1 | Air Regulator Body | 28 ft.-lbs. [38.0 m-N] |
| 2 | Shaft Assembly — Rubber | 33 ft.-lbs. [44.7 m-N] |
| 3 | Shaft Assembly — Teflon® | 58 ft.-lbs. [78.6 m-N] |
| 4 | Small Clamp Band | 90 in.-lbs. [10.2 m-N] |
| 5 | Large Clamp Band | 28 ft.-lbs. [38.0 m-N] |

WILDEN'S SPECIALTY PUMPS

M8 STALLION

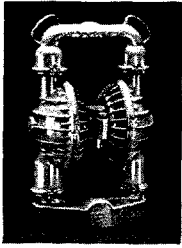

2" inlet. Solids clearance up to 3/4". Built to handle rough treatment: cast-in handles for easy portability, reinforced shaft and high impact polyurethane base.

SOLENOID-OPERATED

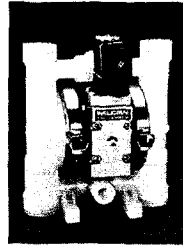

Each stroke of this pump is controlled by electrical impulses making it ideal for batching, metering, and other electrically controlled dispensing applications.

M1 ULTRAPURE III

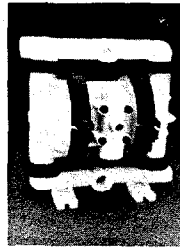

1/2" inlet. Teflon® PFA construction, temperatures to 300°F. Up to 14 GPM. Materials of construction have been selected to reduce contamination while providing a safer work environment.

FOOD PROCESSING

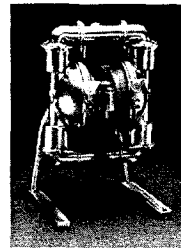

Constructed with FDA approved materials: bead blasted 316 Stainless Steel construction with tri-clamp porting and wing-nut fasteners. Foodmaster™ (pictured) is USDA accepted.

THE WILDEN PUMP LINE

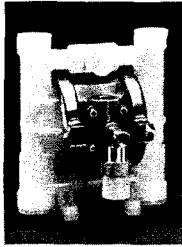

M.025 (CHAMP SERIES)

MODEL M.025

- 1/2" Inlet
- Up To 4.5 GPM
- 125 Max. PSIG
- Max. Particle Size: 1/16"

Materials of Construction: PVDF, Acetal, Polypropylene, Carbon-filled Acetal

Suction Lift: (Rubber) Dry: 4.5' Wet: 25' (Teflon®) Dry: 4.5' Wet: 25'

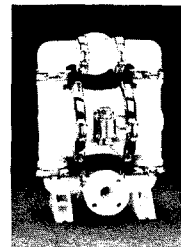

M4 PLASTIC (CHAMP SERIES)

MODEL M4

- 1 1/2" Inlet
- Up To 73 GPM
- 125 Max. PSIG
- Max. Particle Size: 1/8"

Materials of Construction: Aluminum, Cast Iron, Stainless Steel, Hastelloy, Polypropylene, PVDF, Teflon® PFA

Suction Lift: (Rubber) Plastic Dry: 17' Wet: 25' (Teflon®) Metal Dry: 21' Wet: 25'

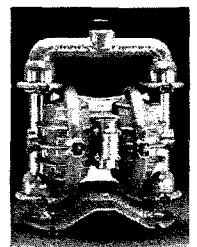

M4 METAL

LUBE-FREE AVAILABLE

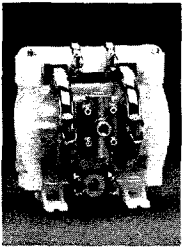

M1 PLASTIC (CHAMP SERIES)

MODEL M1

- 1/2" Inlet
- Up To 14 GPM
- 110 Max. PSIG
- Max. Particle Size: 1/16"

Materials of Construction: Polypropylene, PVDF, Teflon®, Graphite-filled Polypropylene, Aluminum, Stainless Steel

Suction Lift: (Rubber) Plastic Dry: 10' Wet: 25' (Teflon®) Metal Dry: 10' Wet: 25'

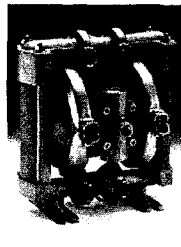

M1 METAL

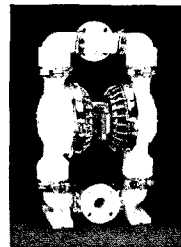

M8 PLASTIC (CHAMP SERIES)

MODEL M8

- 2" Inlet
- Up To 155 GPM
- 125 Max. PSIG
- Max. Particle Size: 1/4"

Materials of Construction: Aluminum, Cast Iron, Stainless Steel, Hastelloy, PVDF, Polypropylene

Suction Lift: (Rubber) Plastic Dry: 17' Wet: 25' (Teflon®) Metal Dry: 20' Wet: 25'

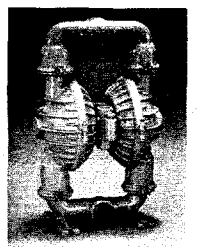

M8 METAL

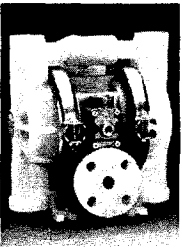

M2R PLASTIC (CHAMP SERIES)

MODEL M2

- 1" Inlet
- Up To 37 GPM
- 125 Max. PSIG
- Max. Particle Size: 1/2"

Materials of Construction: Aluminum, Stainless Steel, Hastelloy, Polypropylene, PVDF

Suction Lift: (Rubber) Plastic Dry: 17' Wet: 25' (Teflon®) Metal Dry: 19' Wet: 25'

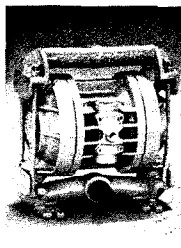

M2 METAL

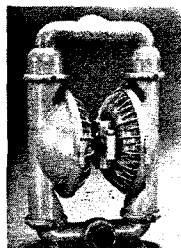

M15

MODEL M15

- 3" Inlet
- Up To 230 GPM
- 125 Max. PSIG
- Max. Particle Size: 3/8"

Materials of Construction: Aluminum, Cast Iron, Stainless Steel, Hastelloy

Suction Lift: (Rubber) Dry: 17' Wet: 25' (Teflon®) Metal Dry: 14' Wet: 25'

For further information contact your local Wilden distributor:

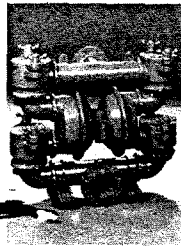

M20

MODEL M20

- 4" Inlet
- Up To 304 GPM
- 125 Max. PSIG
- Max. Particle Size: 1 1/2"

Materials of Construction: Cast Iron

Suction Lift: Dry: 13' Wet: 25'

WILDEN PUMP & ENGINEERING COMPANY

22069 Van Buren St., Grand Terrace, CA 92313-5651
(909) 422-1730 • FAX (909) 783-3440

APPENDIX H

SECTION 6

PUMP DATA

PUMP P - 205

Manufacturer: Goulds

Model: LF3196

Size: 1X1.5-4

Manufacturer

Contact: Mike Compton

Phone

Number: (770) 446-3369

PUMP P - 245

Manufacturer: Goulds

Model: LF3196

Size: 1X1X2-10

Manufacturer

Contact: Mike Compton

Phone

Number: (770) 446-3369

GOULDS PUMPS

legould.wp

Site location: Camp Lejeune, OU2, N.C.
Date service man on site: February 8, 1996
Name of service man: Mr. Bill Lynch, 910-799-8800

Questions & Comments:

1. Question: Before you turn on the pump, what item(s) has to be turned on first?

Comments: Before the pump is turned on, the **seal water** to the packing must be turned on first. That means pump P-245 must be turned on to supply the seal water to all the pumps, otherwise the pump packing seals may be damaged. The seal water pump develops 50 psi during today's startup.

2. Question: What other items has to be turned on before starting the pump?

Comments: For all flooded suction pumps (that is pumps sitting at the bottom of the tanks) the pump suction inlet valves and discharge valves have to be opened otherwise the pump could be damaged by dead heading the water.

3. Question: What should the low level shut off in the tank be set at for the pumps to operate properly?

Comments: The low level in the tank for pump shut off should be set at a minimum of 1 foot above the center line of the suction pipe.

4. Question: What pressure should the seal water be set at for the pumps?

Comments: The seal water pressure should be set at approximately 20 to 25 psi. Goulds has issued a recommended seal water pressure list for all the pumps to OHM and this list should be followed. The method of setting the pressure is by setting the seal pressure 10 psi higher than the stuffing box pressure. And the stuffing box pressure is equal to the sum of the suction pressure plus 25% of the discharge pressure.

5. Question: What is the flow rate of water to the pump seals?

Comments: The water flow rate to the pump seal should be approximately 0.5 gpm.

5. Question: What are the maintenance for these pumps?

Comments: The oil in the pumps should be changed after the first 200 hours, and every

3 months or 2,000 hours thereafter.

6. Question: Are there any maintenance needed for the pump motor?

Comments: The pump motor should be greased every 3 months or 2,000 hours. When greasing the motor, be sure to remove the relief plug and see that the old grease comes out.

7. Question: What are other maintenance required?

Comments: The flow and pressure developed by the pump should be checked periodically. If say after one year, the flow and pressure deteriorates, the impeller clearance should be checked and adjusted using the impeller external adjustment bolt. If it does not help, the pump will need to be disassembled and inspected for wear. The impeller and the pump may need to be send in for repair or overhaul.

8. Question: How long do these pumps last?

Comments: If these pumps are properly maintained, they should last minimum two years on up to four to five years or even longer before they will need re-building.

9. Question: If the process has to cycle the pumps on and off, would that hurt the pump?

Comments: Cycling the pump on and off will not hurt the pump as long as the seal water is on and the flow is maintained.

10. Question: What should the rotation of the pump be?

Comments: It is very critical that the pump is turning clockwise or the pump will be damaged. The impeller is screwed on to the shaft, turning counterclockwise will unscrew the impeller and damage the pump.

The clockwise or right hand rotation can be confirmed by standing at the end of the motor and looking at the shaft.

Engineering Document Package

Goulds Serial # 786D827
Cust: OHM REMEDIATION SERVICES CORP.
P.O. # 1005407
Item # P-205 PROJ. CAMP LEJEUNE
Service: SPENT BACKWASH PUMP

| SUBMITTAL REVIEW | |
|---|---|
| REVIEW IS FOR GENERAL COMPLIANCE WITH CONTRACT DOCUMENTS. NO RESPONSIBILITY IS ASSUMED FOR CORRECTNESS OF DIMENSIONS OR DETAILS. THE CONTRACTOR/SUPPLIER SHALL ASSUME FULL RESPONSIBILITY FOR DEVIATIONS FROM CONTRACT REQUIREMENTS NOT SPECIFICALLY INDICATED ON THIS SUBMITTAL. | |
| <input checked="" type="checkbox"/> NO EXCEPTIONS | <input type="checkbox"/> MAKE CORRECTIONS NOTED |
| <input type="checkbox"/> AMEND AND RESUBMIT | <input type="checkbox"/> REJECTED - SEE REMARKS |
| Date <u>6-21-95</u> By <u>B. N. [Signature]</u> | |
| OHM REMEDIATION SERVICES CORP. NORCROSS, GEORGIA | |

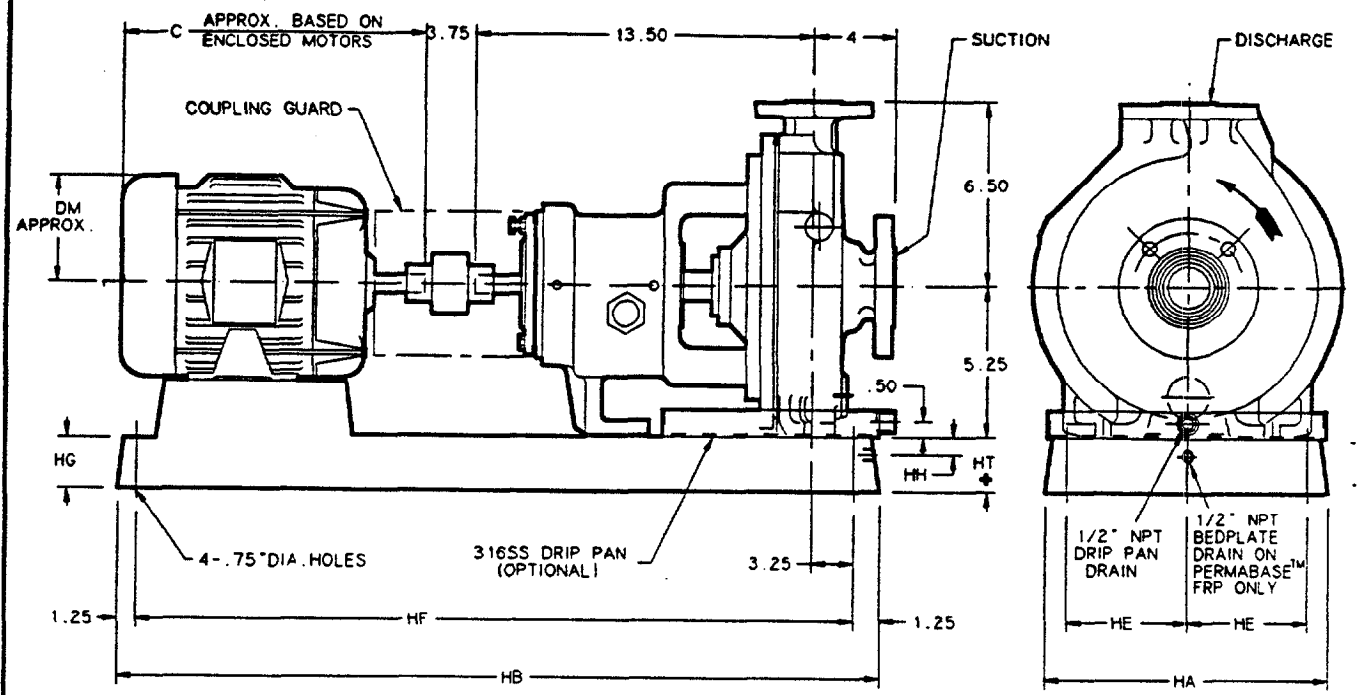

| MOTOR DIMENSIONS (TEFC) | | | | | |
|-------------------------|------|----|----|-----------------|------------|
| MOTORS | | C | DM | WT. INCL. CPLG. | BDPLT. NO. |
| NEMA | IEC | | | | |
| 56 | 80 | 11 | 4 | 35 | 1 |
| 143T | 90S | 13 | 4 | 40 | 1 |
| 145T | 90L | 14 | 4 | 45 | 1 |
| 182T | 100L | 15 | 5 | 65 | 2 |
| 184T | 112M | 16 | 5 | 75 | 2 |
| 213T | 132S | 18 | 6 | 150 | 2 |
| 215T | 132M | 20 | 6 | 160 | 2 |
| 254T | 160M | 23 | 7 | 255 | 3 |
| 256T | 160L | 24 | 7 | 280 | 3 |
| 284T | 180M | 26 | 8 | 375 | 3 |
| 284TS | ---- | 25 | 8 | 345 | 3 |
| 286T | 180L | 27 | 8 | 430 | 3 |
| 286TS | ---- | 26 | 8 | 380 | 3 |

| BEDPLATE DIMENSIONS | | | | | | | | | | | |
|---------------------|----|----|-----------|------|-----------|------|------|-------|------|-----------|-----|
| NO. | HA | HB | HT | | HG | | HE | HF | HH | WEIGHT | |
| | | | CAST IRON | FRP | CAST IRON | FRP | | | | CAST IRON | FRP |
| 1 | 10 | 35 | 3.00 | 3.19 | 2.69 | 3.00 | 4.00 | 32.50 | 1.19 | 75 | 22 |
| 2 | 12 | 39 | 3.25 | 3.69 | 3.06 | 3.12 | 4.50 | 36.50 | 1.38 | 80 | 29 |
| 3 | 15 | 46 | 5.88 | 5.94 | 4.12 | 4.00 | 6.00 | 43.50 | 1.44 | 120 | 52 |

| PUMP SIZE | | | |
|----------------|--------------|--------------|--------|
| DISCHARGE SIZE | SUCTION SIZE | CASING CLASS | WEIGHT |
| 1 | 1 1/2 | 4 | 84 |
| 1 | 1 1/2 | 8 | 100 |

| AVAILABLE OPTIONS | |
|-----------------------------|---|
| BEDPLATE | <input checked="" type="checkbox"/> CAST IRON <input type="checkbox"/> PERMABASE™ FRP |
| 316SS DRIP PAN | <input type="checkbox"/> FURNISHED <input checked="" type="checkbox"/> NOT FURNISHED |
| FLANGES | <input checked="" type="checkbox"/> 150# ANSI RAISED FACE <input type="checkbox"/> 300# ANSI RAISED FACE |
| COUPLING GUARD FURNISHED BY | <input checked="" type="checkbox"/> GOULDS <input type="checkbox"/> OTHERS |

◆ TOLERANCE IS +.38 -0 FOR CAST IRON BEDPLATE.

■ DISCHARGE FLANGE WILL BE THREADED, AS FOLLOWS:
150# : 4-1/2-13 UNC-2B
300# : 4-5/8-11 UNC-2B

INSTALL FOUNDATION BOLTS IN PIPE SLEEVES. ALLOW FROM .75" TO 1.50" FOR GROUTING. SEE INSTRUCTION BOOK FOR DETAILS.

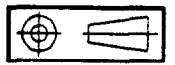

FOR TAPPED OPENINGS REFER TO DRAWING NO. A05057A.

CERTIFIED FOR CONSTRUCTION PURPOSES ONLY WHEN SIGNED.
SIGNATURE *Joyce Sutterby* DATE 6-8-95

Goulds Serial # 786D827
Cust: OHM REMEDIATION SERVICES CORP.
P.O. # 1005407
Item # P-205 PROJ. CAMP LEJBUWE
Service: SPENT BACKWASH PUMP

| | | | | | |
|-------|--|-------------------------|--------------------|---------------|------------|
| ISSUE | DRAWING IS NOT TO SCALE DIMENSIONS IN INCHES WEIGHTS (LBS) ARE APPROXIMATE | DRAWN TEL 6-17-92 | DRAWING A05058A | REVISION 0 | ISSUE 0 |
| | | APPROVED DJC 9-30-92 | | | |



GOULDS PUMPS, INC.

INDUSTRIAL PRODUCTS GROUP
ENGINEERED PRODUCTS DIV.

PUMP TAPPED OPENINGS
MODEL LF 3196 STX

TAPPED OPENINGS

| NO. | SIZE | QTY. | PURPOSE | FURNISHED | | NO. | SIZE | QTY. | PURPOSE | FURNISHED | |
|-----|------|------|-----------------------|-----------|----|-----|------|------|-------------------------|-----------|----|
| | | | | YES | NO | | | | | YES | NO |
| TB | 1/2 | 1 | CASING DRAIN | X | | TL1 | --- | 2 | FRAME COOLER ACCESS | X | |
| TC | 1/4 | 1 | BY-PASS CONNECTION | | X | TN | 1/4 | 4 | GREASE FITTING | X | |
| TD | 1/4 | 1 | DISCHARGE GAUGE CONN. | X | | TN2 | 1/4 | 2 | OIL MIST INJECTION PORT | X | |
| TE | 1/4 | 1 | SUCTION GAUGE CONN. | | | TY | 1/2 | 1 | OIL FILL | X | |
| TF | 3/8 | 1 | BEARING FRAME DRAIN | X | | TZ | 1/4 | 1 | TRICO OILER CONNECTION | X | |
| TL | 1/2 | 2 | FRAME COOLING CONN. | | X | | | | | | |

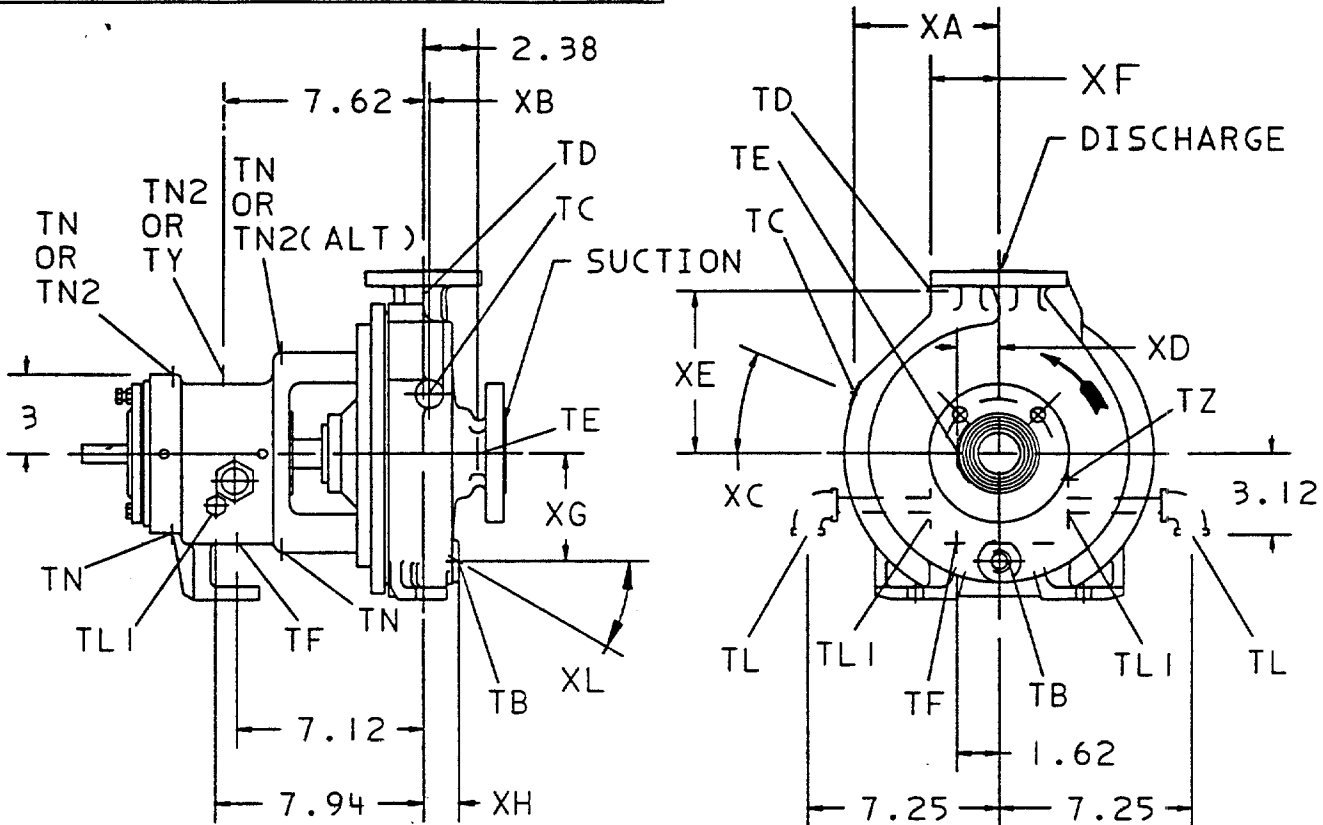

PUMP DIMENSIONS

| ANSI NO. | SIZE | XA | XB | XC | XD | XE | XF | XG | XH | XL |
|----------|-----------|------|-----|-------|------|------|------|------|------|-----|
| AA | 1X1 1/2-4 | 3.25 | .85 | 22.5° | 1.19 | 6.00 | 2.12 | 3.25 | 1.12 | 30° |
| AA | 1X1 1/2-8 | 5.12 | .21 | 22.5° | 1.44 | 5.81 | 2.12 | 3.88 | 1.25 | -- |

CERTIFIED FOR CONSTRUCTION PURPOSES ONLY WHEN SIGNED.

SIGNATURE *Joyce Sutterby* DATE *6-8-95*

Goulds Serial # 786D827
Cust: OHM REMEDIATION SERVICES CORP.
P.O. # 1005407
Item # P-205 PROJ. CAMP LEJEUNE
Service: SPENT BACKWASH PUMP

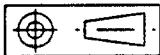

ISSUE

DRAWING IS NOT TO SCALE
DIMENSIONS IN INCHES

DRAWN TEL 6-17-92
APPROVED DJC 9-15-92

DRAWING
A05057A

REVISION
1

ISSUE
0

STUFFING BOX/SEAL CHAMBERS/DYNAMIC SEAL

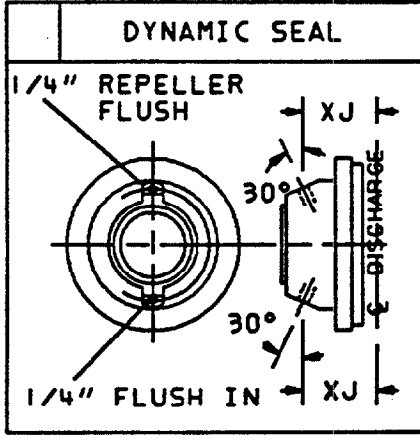
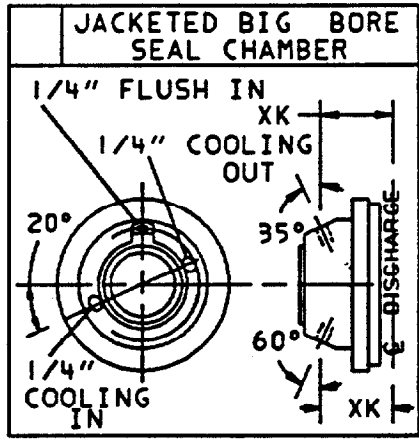
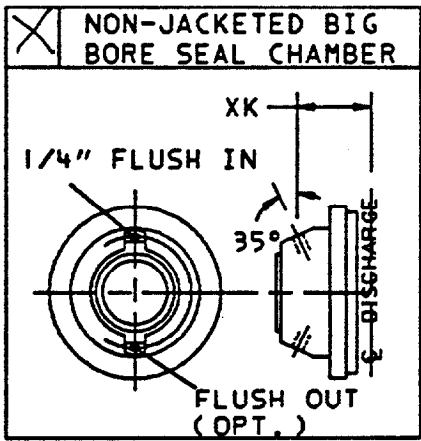
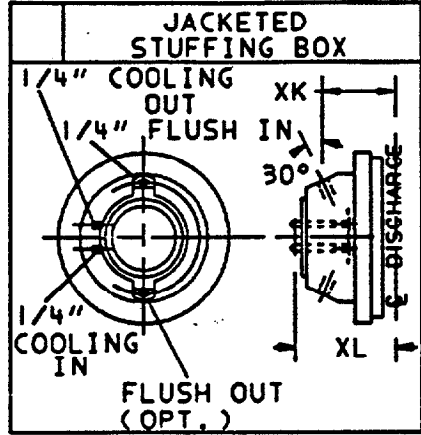
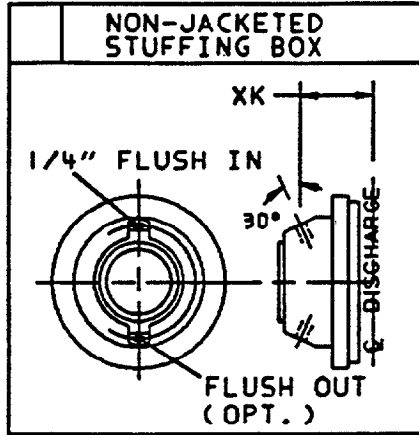

| PUMP DIMENSIONS | | | |
|--|-----------|------|------|
| PUMP MODEL | (MAXIMUM) | | |
| | XK | XJ | XL |
| 3196 | 2.00 | 2.50 | 4.00 |
| 3796 | 4.00 | 5.00 | 6.00 |
| 3996 | 2.00 | 2.50 | 4.00 |
| <input checked="" type="checkbox"/> LF3196 | 2.00 | 2.50 | 4.00 |
| CV3196 | 4.00 | 5.00 | 6.00 |

CERTIFIED FOR CONSTRUCTION PURPOSES ONLY WHEN SIGNED.
SIGNATURE *Joseph Sutterby* DATE 6-8-95

Goulds Serial # 786D827
Cust: OHM REMEDIATION SERVICES CORP.
P.O. # 1005407
Item # P-205 PROJ. CAMP LEJBUNE
Service: SPENT BACKWASH PUMP

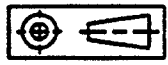

NOTE: TAPPED OPENINGS NOT AVAILABLE ON TAPER BORE™ PLUS SEAL CHAMBERS.

| | | | | | |
|-------|---|------------------------|--------------------|---------------|------------|
| ISSUE | DRAWING IS NOT TO SCALE DIMENSIONS IN INCHES | DRAWN TJA 9-1-94 | DRAWING A05460A | REVISION 0 | ISSUE 0 |
| | | APPROVED PTM 9-6-94 | | | |



GOULDS PUMPS, INC.

INDUSTRIAL PRODUCTS GROUP
ENGINEERED PRODUCTS DIV.

TAPPED OPENINGS
GROUP-STX

STUFFING BOX/SEAL CHAMBER GLAND OPTIONS
OPTION FURNISHED WHEN CHECKED

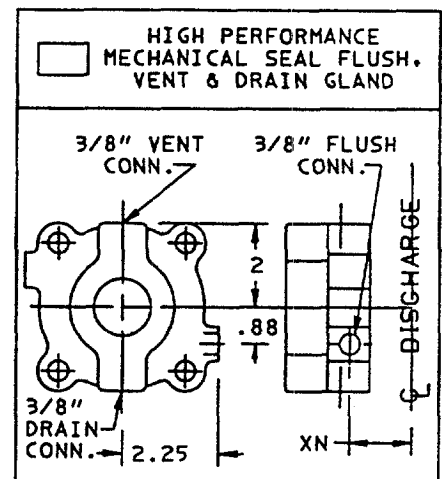
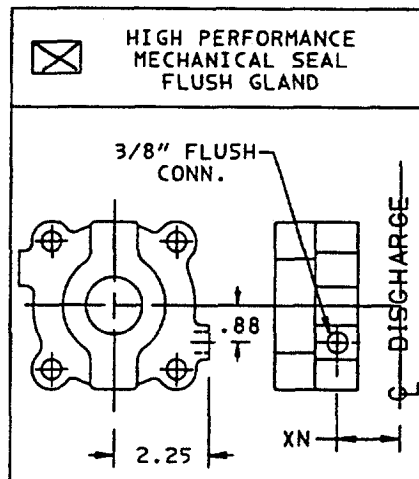
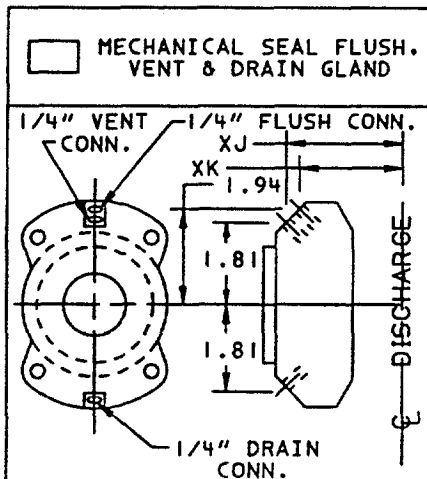
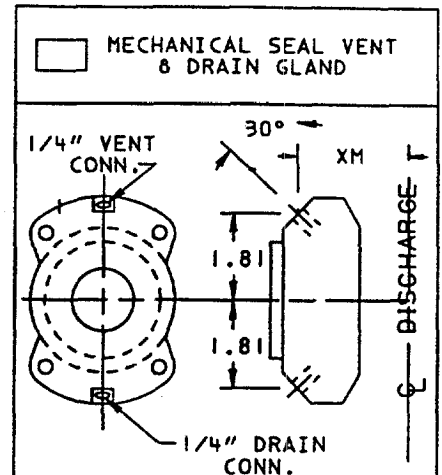
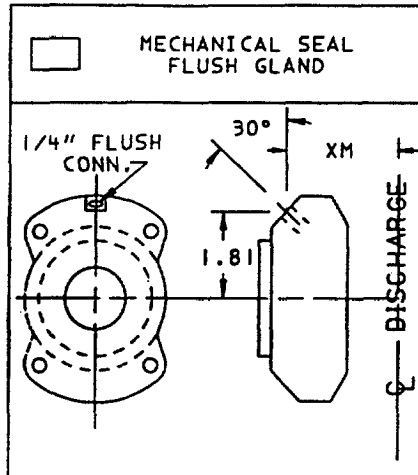
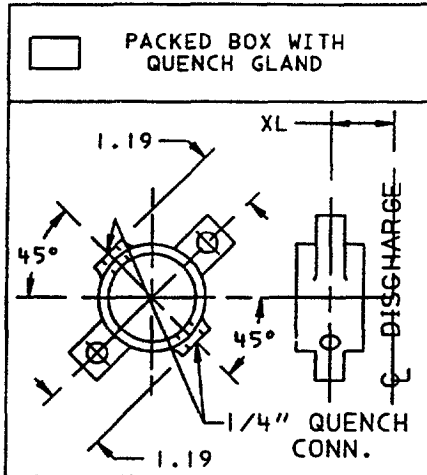

PUMP DIMENSIONS

| PUMP MODEL | XJ | XK | XL | XM | XN |
|--|------|------|------|------|------|
| 3196 | 3.81 | 3.00 | 3.25 | 3.50 | 3.44 |
| 3796 | 5.81 | 5.00 | 5.25 | 5.50 | 5.44 |
| 3996/ST | 3.81 | 3.00 | 3.25 | 3.50 | 3.44 |
| <input checked="" type="checkbox"/> LF3196 | 3.81 | 3.00 | 3.25 | 3.50 | 3.44 |
| CV3196 | 6.00 | 5.50 | 5.75 | 6.00 | 5.94 |

CERTIFIED FOR CONSTRUCTION PURPOSES ONLY WHEN SIGNED.

SIGNATURE *Joyce Sutterby* DATE 6-8-95

Goulds Serial # 786D827
Cust: OHM REMEDIATION SERVICES CORP.
P.O. # 1005407
Item # P-205 PROJ. CAMP LEJBUMB
Service: SPENT BACKWASH PUMP

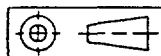

ISSUE

DRAWING IS NOT TO SCALE
DIMENSIONS IN INCHES

DRAWN TJA
9-01-94
APPROVED PTH
09-01-94

DRAWING
A05464A

REVISION
0

ISSUE
0

Date 11-02-1992

Rev. Date

GOULDS PUMPS, INC.
Seneca Falls, NY 13148

CENTRIFUGAL PUMP CHARACTERISTICS

RPM 1750 CDS 4540

Model LF 3196 STX

Size 1X1.5-4

Imp. Dwg. C03496A

Pattern 68699

Eye Area .8 in²

3/4" IMP. DIA.

Goolds Serial # 786D827
Cust: OHM REMEDIATION SERVICES CORP.
P.O. # 1005407
Item # P-205 PROJ. CAMP LEJEUNE
Service: SPENT BACKWASH PUMP

NPSH_R

CERTIFIED PERFORMANCE DATA
GOULDS PUMPS, INC.
ENGINEERING PRODUCTS DIVISION
Seneca Falls, N. Y.
Signed: *James Hall*

HEAD

FEET
25
20
15
10
5
0

metres
9
8
7
6
5
4
3
2
1
0

CAPACITY

0 2 4 6 8 10 12 14 16 GPM
0 .5 1 1.5 2 2.5 3 3.5 m³/h

1 HP MINIMUM
MOTOR SIZE

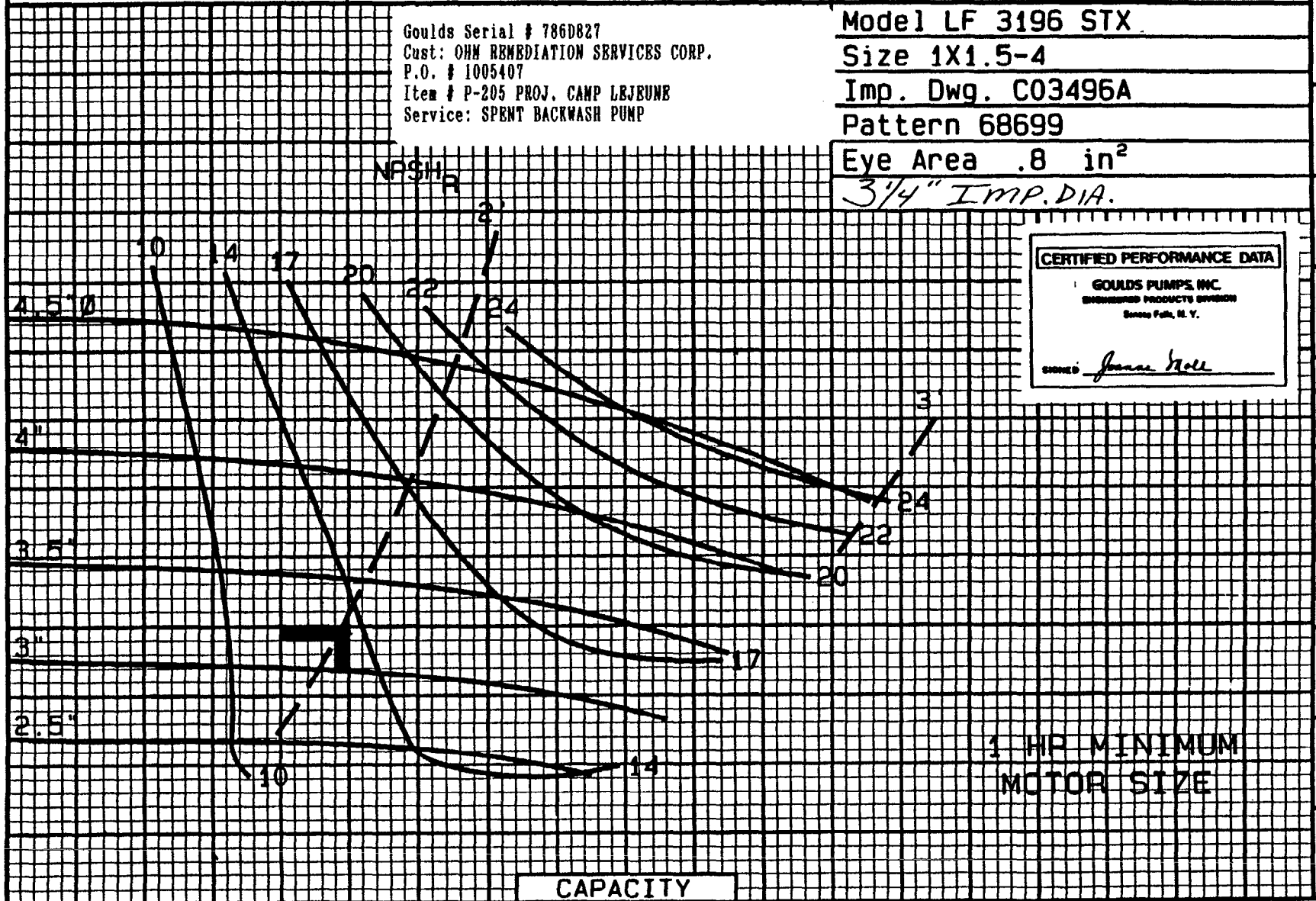

BILL OF MATERIAL
CONSTRUCTION: DUCTILE IRON W/ 316SS

| ITEM NO | QTY PER PUMP | PART NAME | MATERIAL |
|---------|--------------|--------------------------|-----------|
| 100 | 1 | CASING | DI |
| 101 | 1 | IMPELLER | 316SS |
| 105 | 2 | LANTERN RING HALF | TEFLON |
| 106 | 1 | STUFFING BOX PKG | NON-ASB |
| 107 | 1 | GLAND | 316SS |
| 112A | 1 | BALL BRG OTBD | 316SS |
| 113A | 1 | PLUG, OIL FILL | STEEL |
| 122 | 1 | SHAFT | STEEL |
| 126 | 1 | SHAFT SLEEVE | 316SS |
| 134 | 1 | BRG HOUSING | CI |
| 136 | 1 | BRG LOCK NUT | STEEL |
| 168A | 1 | BALL BRG INBD | STEEL |
| 184 | 1 | S.B. COVER/SEAL CHAM. | DI |
| 228 | 1 | FRAME | DI |
| 250 | 1 | GLAND, MECH. SEAL | 316SS |
| 319 | 1 | SIGHT GLASS | STL/GLASS |
| 332A | 1 | LBYSR SEAL OTBD W/O-RING | TFL/GPH |
| 333A | 1 | LBYSR SEAL INBD W/O-RING | TFL/GPH |
| 351 | 1 | GASKET-CASE | EPDM-RBR |
| 353 | 2 | STUD-GLAND | 316SS |
| 355 | 2 | NUT GLAND STUD | 304SS |
| 361A | 1 | RTNG RING-BRG HSG | STEEL |
| 370 | 4 | H CAP SCR-FR-CASE | STEEL |
| 370B | 4 | H CAP SCR-ADPTR-FR | STEEL |
| 370C | 3 | H TAP BOLT-BRG HSG | STEEL |
| 370D | 3 | H TAP BOLT-IMPLR-ADJ | STEEL |
| 370H | 2 | STUD-COVER-ADPTR | 304SS |
| 382 | 1 | BRG LOCKWASHER | STEEL |
| 400 | 1 | KEY, SQUARE | STEEL |
| 408A | 1 | MAG. PLUG-OIL DRAIN | STEEL |
| 408J | 1 | PLUG, SIGHT OILER | STEEL |
| 408H | 4 | PLUG, OIL MIST CONN | STEEL |
| 412A | 1 | O-RING IMPELLER | TEFLON |
| 418 | 3 | H TAP BOLT-JACKING | 304SS |
| 423 | 3 | JAM NUT FOR 370D | STEEL |
| 496 | 1 | O-RING-BRG HSG | BUNA-RBR |
| 497F | 1 | O-RING-OTBD SEAL ROT. | VITON |
| 497G | 1 | O-RING-OTBD SEAL STA. | VITON |
| 497H | 1 | O-RING-INBD SEAL ROT. | VITON |
| 497J | 1 | O-RING-INBD SEAL STA. | VITON |
| 503 | 1 | ADAPTER RING | DI |

BOTTLE OILER
OPTION FURNISHED WHEN CHECKED

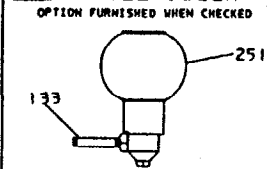

| ITEM NO | NO REQ'D | PART NAME | MAT'L |
|---------|----------|--------------|------------|
| 133 | 1 | PIPE NIPPLE | STEEL |
| 251 | 1 | BOTTLE OILER | ALUM/GLASS |

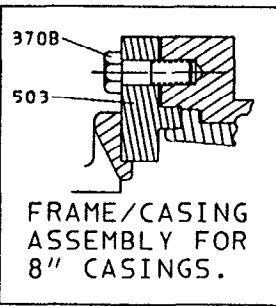

- * RECOMMENDED SPARE PARTS.
- Ⓐ ITEM 370 IS QTY 8 FOR 8" CASINGS.
- Ⓑ GLAND BOLTING FOR PACKING GLAND (ITEM 353 & 355) IS QTY 2. FOR MECHANICAL SEAL QTY 4.
- Ⓒ ITEMS NOT ILLUSTRATED.

STANDARD OIL LUBE

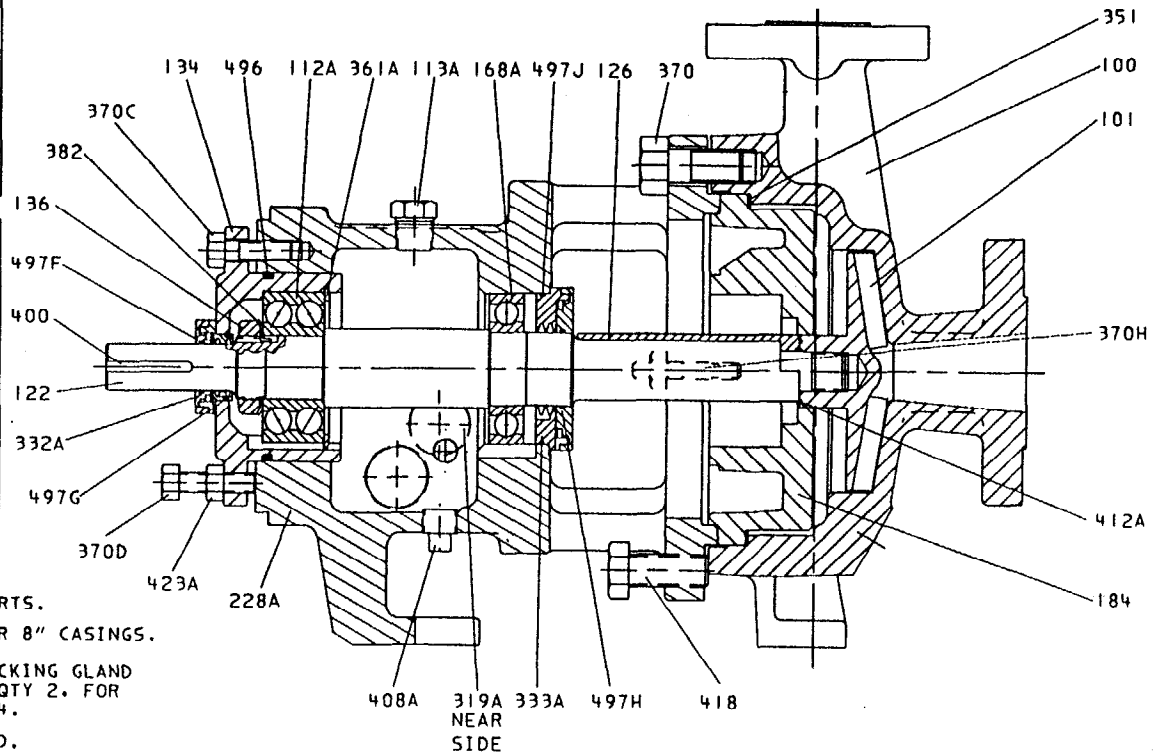

STUFFING BOX COVER / SEAL CHAMBER OPTIONS - CHECK OPTION REQUIRED

- STUFFING BOX
- NONJACKETED (SHOWN)
- JACKETED

REFER TO SEAL DRAWING NO. 265-251541 ATTACHED TO FOLLOW

- TAPER BORE™ PLUS

- BIG BORE™ STD. FLUSH
- NONJACKETED (SHOWN)
- JACKETED

- BIG BORE™ WITH INTERNAL BY-PASS

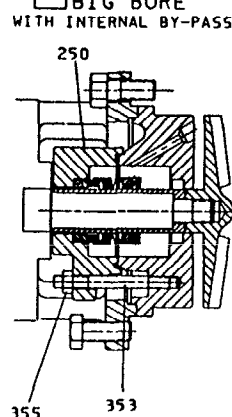
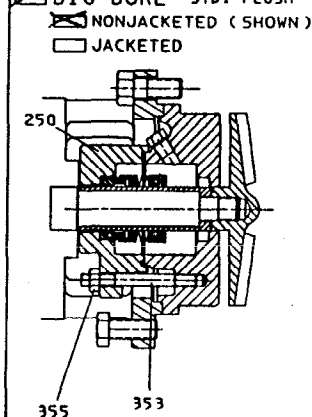
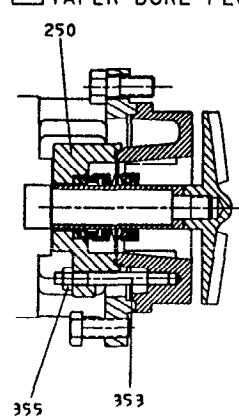
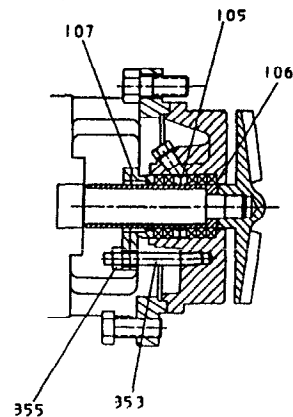

Goulds Serial # 786D827
Cust: OHM REMEDIATION SERVICES CORP.
P.O. # 1005407
Item # P-205 PROJ. CAMP LEJBUNB
Service: SPENT BACKWASH PUMP

PUMP CROSS SECTION DRAWING
MODEL LF 3196 STX



GOULDS PUMPS, INC.
INDUSTRIAL PRODUCTS GROUP
ENGINEERED PRODUCTS DIV.

| | | | |
|--------------------------|----------------------------|-----------------------------|------------------------------------|
| DRAWN DLG 08-13-92 | CHECKED TEL 08-13-92 | APPROVED DJC 08-13-92 | THIRD ANGLE PROJECTION ⊕ f=7 |
| DRAWING IS NOT TO SCALE | | | REV. |
| DRAWING B02383A2 | | | 1 |

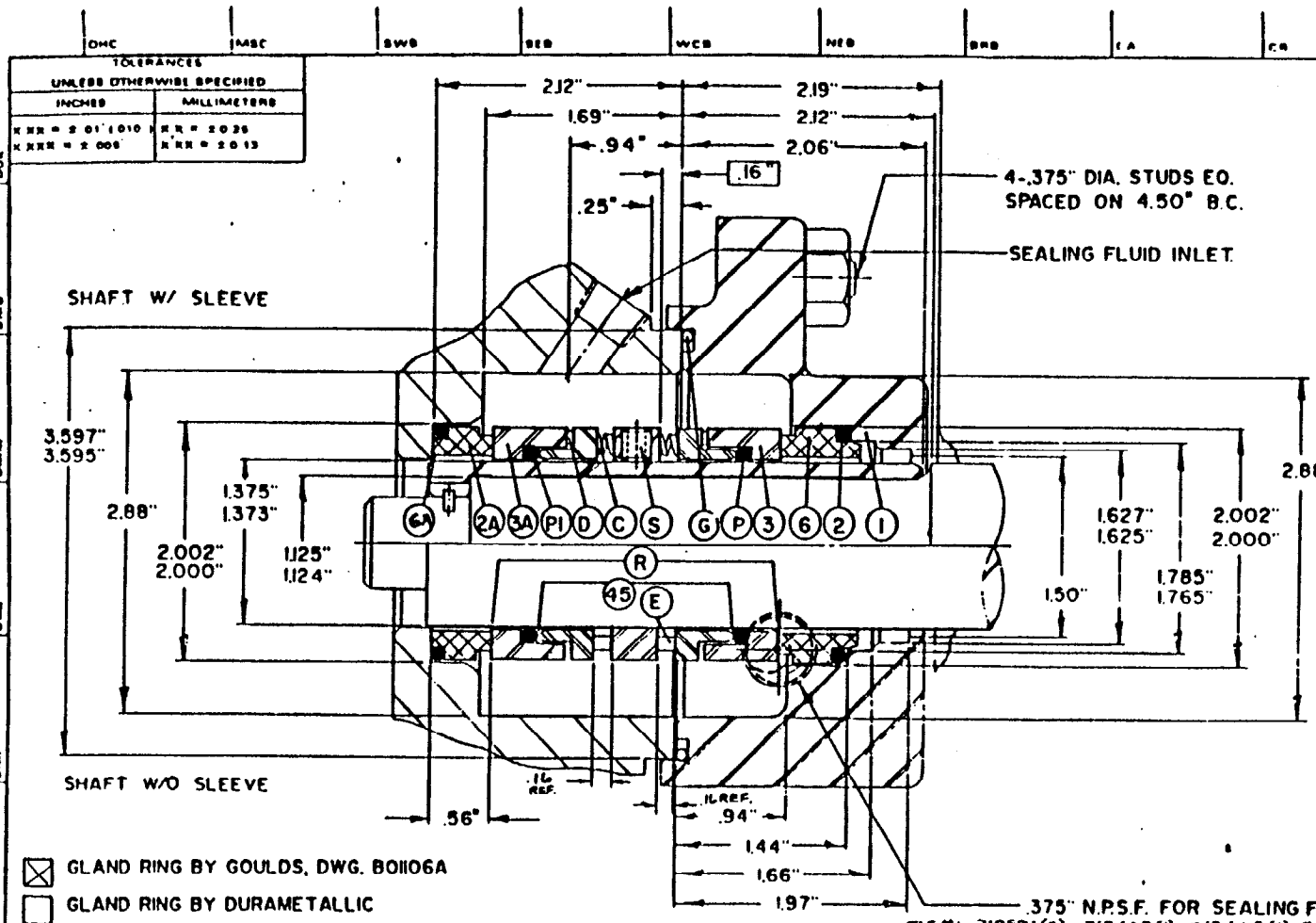

| NO | DATE | REVISION | BY | CHK'D |
|----|------|----------|----|-------|
| | | | | |
| | | | | |

Goulds Serial # 786D827
 Cust: OHM REMEDIATION SERVICES CORP.
 P.O. # 1005407
 Item # P-205 PROJ. CAMP LEJEUNE
 Service: SPENT BACKWASH PUMP

SEE INSTALLATION INSTRUCTIONS FOR
 REQUIRED MECHANICAL CONDITION OF
 EQUIPMENT.

| PART REF. NO. | PRODUCT CODE |
|---------------|--------------|
| R | TEJRI375CA4 |
| P | MYRI375333 |
| 2 | YSEJ375ABR |
| 6 | MYSRI750333 |
| 2A | AJ375MT3 |
| 6A | MYRI625333 |

- GLAND RING BY GOULDS, DWG. B0106A
- GLAND RING BY DURAMETALLIC

| R | ROTAARY UNIT CONSISTING OF | P | SHAFT PKG. | VITON |
|----|----------------------------|----|------------|--------------|
| 3 | SEAL RING TUNCARB 626 | PI | SHAFT PKG. | VITON |
| 3A | SEAL RING TUNCARB 626 | 2 | INSERT | NO. 5 CARBON |
| 45 | COMP UNIT 316 S.S. | 6 | O-RING | VITON |
| C | SPRINGS 20 S.S. | 2A | INSERT | NO. 5 CARBON |
| D | DRIVE PINS 20 S.S. | 6A | O-RING | VITON |
| E | SPRING PINS 20 S.S. | G | GASKET | NON-ASB |
| S | SET SCREWS 20 S.S. | I | GLAND RING | 316SS |

CUSTOMER GOULDS PUMPS, INC., SENECA FALLS, NY
 P.O. NO. MS 57227 P.O. NO. NAO4482-9
 USER _____
 EQUIP. TYPE & SIZE: GOULDS 3196 ST ANSI PLUS PUMPS
 EQUIP. SERIAL NO: 786D827
 PRODUCT: WATER
 PRESSURE: _____
 TEMP: 70°F
 R.P.M.: 1800
 S.P.G.R.: 1.00
 REFERENCE DWG NO: C01389A

DURA SEAL TYPE: DOUBLE RO SEAL SIZE: 1.375"
 DURAMETALLIC CORPORATION KALAMAZOO, MI.
 MAX CODE: E U 5 - - V V
 SCALE NTS: DATE 10-16-89
 ORDER PARTS BY: B.M. NO: 133581
 DATE: 10-16-89
 APPROV BY: _____
 DWN NLS: _____
 FORM DWG: _____
 DWN NLS: _____
 CHM D: JF
 DWG NO: 265-251541
 786827#3

RECOMMENDED SPARE PARTS 2, 2A, 3, 3A, 6, C, P, I, S, 6A

CUSTOMER INFORMATION

Goulds Serial # 786D827
Cust: OHM REMEDIATION SERVICES CORP.
P.O. # 1005407
Item # P-205 PROJ. CAMP LEJBUNG
Service: SPENT BACKWASH PUMP

EQUIPMENT IDENTIFICATION

MODEL LF 3196STX SIZE 1X1 1/2-4
LUBRICATION OIL
CONST. DI / 316SS

| PART LUBRICATED | LUBRICANT | | FILL CAPACITY | CONSUMPT. AMT. / TIME | RECOMMENDED LUBRICANT MFR. & NO. & REMARKS |
|---------------------------|------------------------|----------|-----------------------------------|--|--|
| | TYPE | VISC. | | | |
| BEARING HOUSING/ FRAME | TURBINE TYPE OIL | ISOVG-68 | APPROX. ONE (1) PT (400 ML) | REFILL AP- PROXIMATELY EVERY (3) THREE MONTHS OR 2000 HRS. | OIL MUST BE VISIBLE AT CENTER OF SIGHT GLASS. |

REV. DATE

| | | | | | |
|--|--|----------------------------------|--------------------------------------|----------------------------------|------------------|
| | | WRITTEN BY FAK 5/1/92 DATE | APPROVED BY J.MOLL DATE 5/1/92 | DRAWING NO. <u>196STX LDS</u> | REV. <u>0</u> |
|--|--|----------------------------------|--------------------------------------|----------------------------------|------------------|



TYPE SC SPACER COUPLINGS

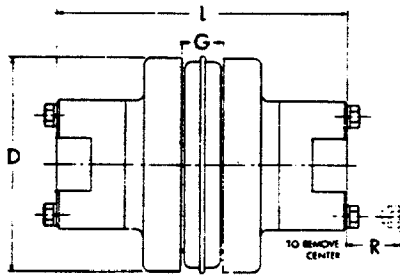
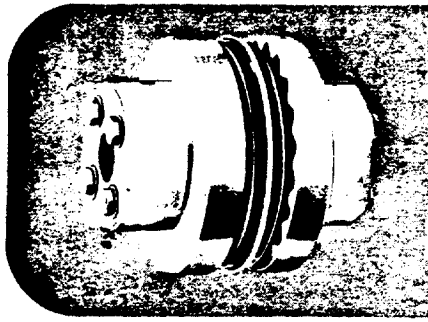

The table below shows assembled dimensions of Sure-Flex Type SC Spacer Couplings. For dimensions of separate components, refer to page 19.

| Coupling Size | Required Distance Between Shafts | Use Flange No. | Use Hub No. | Max. Bore Std. KS | Dimensions | | | | Wt. ⁽²⁾ (lbs.) |
|---------------|----------------------------------|----------------|-------------|----------------------|------------|------------------|--------|--------|---------------------------|
| | | | | | D | L ⁽¹⁾ | G | R | |
| 4JSC | 3 1/2 | 4JSC35 | ... | 1 1/2 ⁽¹⁾ | 2.460 | 5 1/2 | 3/8 | ... | 2.7 |
| 5SC | 3 1/2 | 5SC35 | 5H | 1 1/8 | 3.250 | 5 5/8 | 3/4 | 7/16 | 4.5 |
| 6SC | 3 1/2 | 6SC35 | 6H | 1 1/8 | 4.000 | 5 1/2 | 7/8 | 3/4 | 7.3 |
| | 4 1/2 | 6SC44 | 6H | 1 3/8 | 4.000 | 6 3/4 | 7/8 | 3/4 | 8.1 |
| 7SC | 5 | 6SC50 | 6H | 1 3/8 | 4.000 | 7 3/8 | 7/8 | 3/4 | 8.7 |
| | 3 1/2 | 7SC35 | 7H | 1 1/2 | 4.625 | 6 3/8 | 1 | 5/8 | 9.9 |
| | 4 1/2 | 7SC44 | 7H | 1 3/8 | 4.625 | 7 1/4 | 1 | 5/8 | 10.8 |
| 8SC | 5 | 7SC50 | 7H | 1 1/2 | 4.625 | 7 7/8 | 1 | 5/8 | 11.4 |
| | 3 1/2 | 8SC35 | 8H | 1 7/8 | 5.450 | 6 3/8 | 1 1/8 | 1 1/16 | 15.2 |
| | 4 1/2 | 8SC44 | 8H | 1 7/8 | 5.450 | 8 3/8 | 1 1/8 | 1 1/16 | 23.2 |
| | 5 | 8SC50 | 8H | 1 7/8 | 5.450 | 8 3/8 | 1 1/8 | 1 3/16 | 17.4 |
| 9SC | 5 | 8SC50-10 | 10H* | 2 3/8 | 5.450 | 9 1/2 | 1 1/8 | 1 3/16 | 27.2 |
| | 3 1/2 | 9SC35 | 9H* | 2 1/8 | 6.350 | 7 1/2 | 1 1/16 | 1 1/16 | 18.6 |
| | 4 1/2 | 9SC44 | 9H* | 2 3/8 | 6.350 | 8 1/2 | 1 1/16 | 1 1/16 | 22.2 |
| | 5 | 9SC50 | 9H* | 2 3/8 | 6.350 | 8 7/8 | 1 1/16 | 1 1/16 | 23.2 |
| | 7 | 9SC50-11 | 11H* | 2 3/8 | 6.350 | 10 3/8 | 1 1/16 | 1 3/16 | 40.4 |
| | 7 1/2 | 9SC70-11 | 11H* | 2 3/8 | 6.350 | 12 3/8 | 1 1/16 | 1 3/16 | 48.2 |
| 10SC | 7 3/4 | 9SC78-11 | 11H* | 2 3/8 | 6.350 | 13 1/8 | 1 1/16 | 1 3/16 | 51.0 |
| | 4 1/2 | 10SC48 | 10H* | 2 3/8 | 7.500 | 9 1/8 | 1 1/8 | 1 3/16 | 37.6 |
| | 5 | 10SC50 | 10H* | 2 3/8 | 7.500 | 9 5/8 | 1 1/8 | 1 3/16 | 38.4 |
| | 7 | 10SC70-13 | 13H* | 3 3/8 | 7.500 | 13 3/8 | 1 1/8 | 1 1/8 | 72.0 |
| 11SC | 7 1/4 | 10SC78-13 | 13H* | 3 3/8 | 7.500 | 14 3/8 | 1 1/8 | 1 1/8 | 76.0 |
| | 10 | 10SC100-13 | 13H* | 3 3/8 | 7.500 | 16 3/8 | 1 1/8 | 1 1/8 | 88.0 |
| | 4 1/2 | 11SC48 | 11H* | 2 7/8 | 8.625 | 10 5/16 | 1 1/8 | 1 3/16 | 54.5 |
| | 5 | 11SC50 | 11H* | 2 7/8 | 8.625 | 10 3/8 | 1 1/8 | 1 3/16 | 54.7 |
| | 7 | 11SC70-14 | 14H | 3 3/8 | 8.625 | 14 7/8 | 1 1/8 | 2 | 86.1 |
| 12SC | 7 1/4 | 11SC78-14 | 14H | 3 3/8 | 8.625 | 15 3/8 | 1 1/8 | 2 | 90.3 |
| | 10 | 11SC100-14 | 14H | 3 3/8 | 8.625 | 17 3/8 | 1 1/8 | 2 | 102.7 |
| | 7 | 12SC70 | 12H* | 2 7/8 | | | | | |
| | 7 1/2 | 12SC78 | 12H* | 2 7/8 | | | | | |
| 13SC | 7 1/2 | 12SC78-14 | 14H | 3 3/8 | | | | | |
| | 10 | 12SC100-14 | 14H | 3 3/8 | | | | | |
| 14SC | 7 1/4 | 13SC78 | 13H* | 3 3/8 | | | | | |
| | | 14SC78 | 14H | 3 3/8 | | | | | |

Goolds Serial # 786D827
 Cust: OHM REMEDIATION SERVICES CORP.
 P.O. # 1005407
 Item # P-205 PROJ. CAMP LEJEUNE
 Service: SPENT BACKWASH PUMP

*Short (HS) hub also available. ■ Approximate weight for completely assembled spacer coupling.
 (1) 4JSC35 x 1 1/2 has shallow keyseat. (2) "L" dimension and weight will change if one or two short (HS) hubs used.
 Note: Refer to page 19 to order — specify components separately.

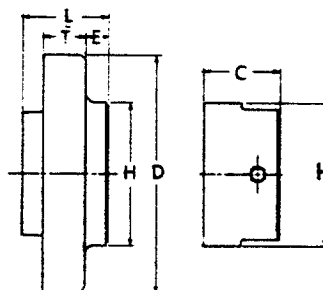
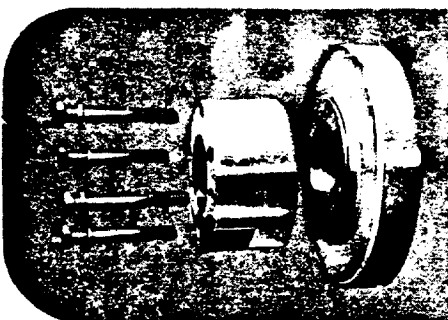

TYPE SC FLANGES AND HUBS

Tables on page 19 provide dimensional information for flanges and hubs used for Spacer Couplings. For assembled dimensions, see table above. Any of the sleeves shown on page 10 may be used.



GOULDS PUMPS, INC.
INDUSTRIAL PRODUCTS GROUP



P.O. Box 738
Seneca Falls, New York 13148
Phone: 800-446-8537
Fax: 800-423-7775

TO: OHM REMEDIATION SERVICES CORP.
5335 TRIANGLE PARKWAY
SUITE 450
ATTN: BUTCH MATTHEWS
NORCROSS, GA 30092

SUBJECT: YOUR P.O. NO. 1005430-1

DATE: 10/06/95

THE FOLLOWING TECHNICAL DATA IS SUBMITTED FOR YOUR REVIEW (SEE BELOW):

| <u>QTY.</u> | <u>DESCRIPTION</u> | <u>DWG.NO.</u> | <u>ITEM NO.</u> | <u>GOULDS F.O. NO.</u> |
|-------------|-------------------------|----------------|-----------------|------------------------|
| 1R+1P | DRIVER PRINT | | P-245 | 788D285 |
| " | DRIVER PERF/ELEC.WIRING | | " | |

 PUMP INSTALLATION OPERATING AND MAINTENANCE MANUALS ATTACHED.

 1 MOTOR INSTALLATION OPERATING AND MAINTENANCE MANUALS ATTACHED.G.E.

 YOUR COMPLETE APPROVAL REQUIRED BEFORE ORDER IS SCHEDULED AND RELEASED TO MANUFACTURING.

 X THE ABOVE LITERATURE IS FOR YOUR INFORMATION AND RECORDS, AND DOES NOT REQUIRE YOUR APPROVAL. RETAIN LITERATURE AS YOUR FINAL DISTRIBUTION.

NOTE: ANY CHANGES MAY AFFECT QUOTED PRICES AND SHIPPING SCHEDULES.

VERY TRULY YOURS,
GARY SAWALL

CC: ATLANTA-M. COMPTON

Goulds Serial #788D285
 Customer: OHM REMEDIATION SERVICES
 P.O. #1005430-1
 Item #P-245
 Service: REUSE WATER

SIZE B DWG NO 225B7601AA

| REVISIONS | | | |
|-----------|-------------|------|----------|
| REV | DESCRIPTION | DATE | APPROVED |
| | | | |

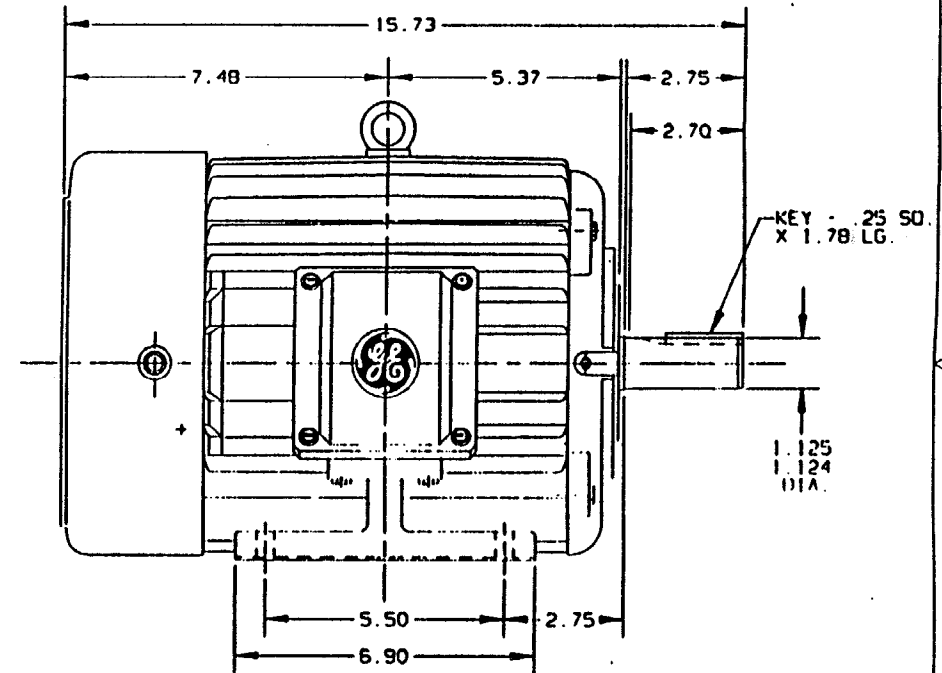
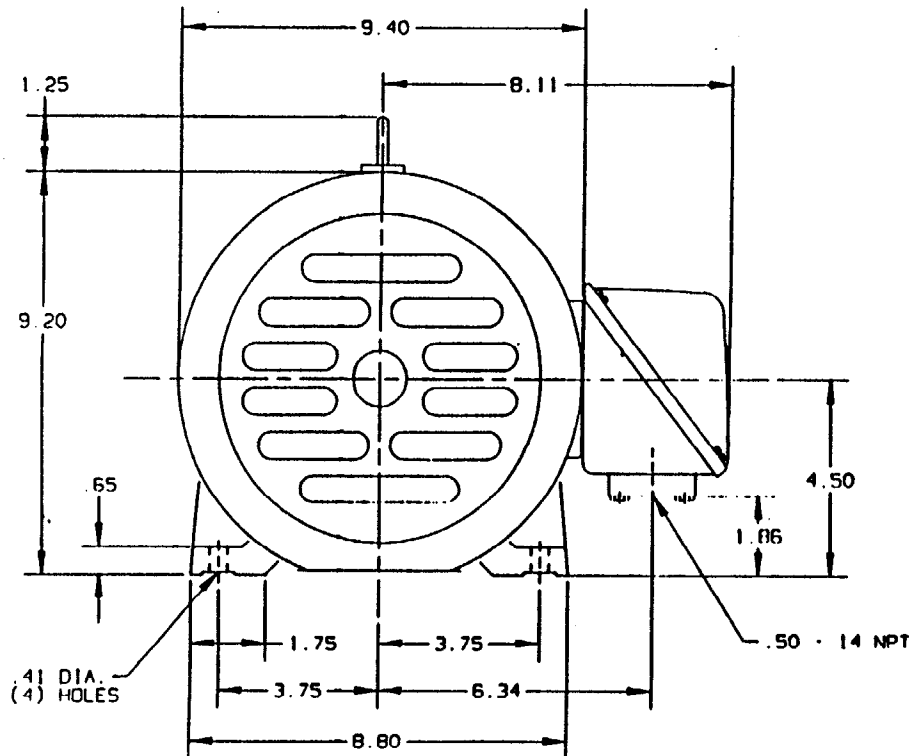

THIRD ANGLE PROJECTION

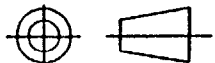

| | | | |
|--|---|----------------------|---|
| UNLESS OTHERWISE SPECIFIED DIMENSIONS ARE IN INCHES TOLERANCES BY: 3 PL. DECIMALS : 2 PL. DECIMALS : ANGLES : FRACTIONS : MATERIAL: APPLIED PRACTICES: | SIGNATURES | DATE | GE Motors Fort Wayne, Indiana |
| | DRAWN R. KOPPE CHECKED R. KOPPE ENGRG ISSUED . 12-12-94 | 09-01-94 12-12-94 | |
| CAD NO. DM180:225B7601AA | SIZE B | FSCM NO. | DWG NO. 225B7601AA |
| | SCALE .35 | | SHEET 1 OF 1 |

Q18TR TO 1



GE Motors
& Industrial Systems

July 18, 1995

Customer Service Dept
Fort Wayne, IN 46802
(219) 439-2000

Customer: GOULDS PUMPS INC
ENGINEERED PRODUCTS DIV
240 FALL ST
SENECA FALLS NY 13148

Customer Order.....: 376711
Customer Part.....: 788D285MT

GEMIS Reqn / Item.....: 69607879 / 10
GEMIS Job Number.....: 950713467

Marks: 376711/ 788D285MT

MODEL NUMBER: 5KS184BC205
Outline Drawing.....: 225B7601AA
Installation manual.....: GEI-56128
Design Code.....: 18TD1006A
Type.....: KS
Frame.....: 184T
Hp.....: 5
Rpm-fl.....: 1750
Phase.....: 3
Volts.....: 230/460
Hz.....: 60
Service Factor.....: 1.15

ESTIMATED WEIGHT ..: 114 Lbs (51.71Kg)
Time Rating.....: CONT
Amb-max.....: 40
Insul Class.....: F
Nema Design.....: B
Code.....: J
Amps-fl.....: 12.3/6.2
Nema Eff Nom.....: 89.5
Nema Eff Guar.....: 83.1
Power Factor.....: 86.5
Bearing-de.....: 6306ZZ
Bearing-ode.....: 6306ZZ

Enclosure.....: Totally Enclosed Fan-Cooled

Additional Motor Data:

USABLE ON 208V NETWORKS AT 13.5 AMPS
4 POLE

Goulds Serial #788D285
Customer:OHM REMEDIATION SERVICES
P.O. #1005430-1
Item #P-245
Service:REUSE WATER

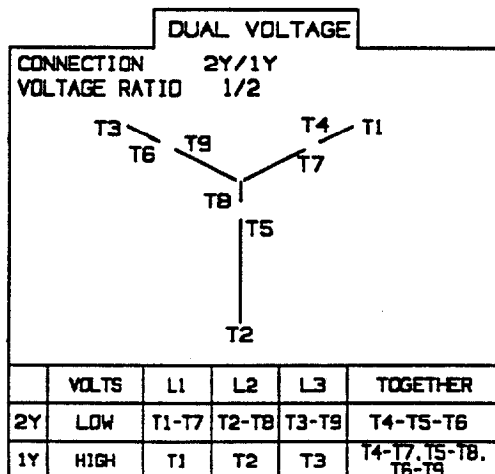

Engineering Document Package

Goulds Serial #788D285
Customer: OHM REMEDIATION SERVICES
P.O. #1005430-1
Item #P-245
Service: REUSE WATER

SUBMITTAL REVIEW

REVIEW IS FOR GENERAL COMPLIANCE
WITH CONTRACT DOCUMENTS
NO RESPONSIBILITY IS ASSUMED FOR
CORRECTNESS OF DIMENSIONS OR DETAILS.
THE CONTRACTOR/SUPPLIER SHALL ASSUME
FULL RESPONSIBILITY FOR DEVIATIONS FROM
CONTRACT REQUIREMENTS NOT SPECIFICALLY
INDICATED ON THIS SUBMITTAL

- NO EXCEPTIONS MAKE CORRECTIONS NOTED
 AMEND AND RESUBMIT REJECTED - SEE REMARKS

Date 7-17-95 By B. H. [Signature]

OHM REMEDIATION
SERVICES CORP.
NORCROSS, GEORGIA



GOULDS PUMPS, INC.
INDUSTRIAL PRODUCTS GROUP

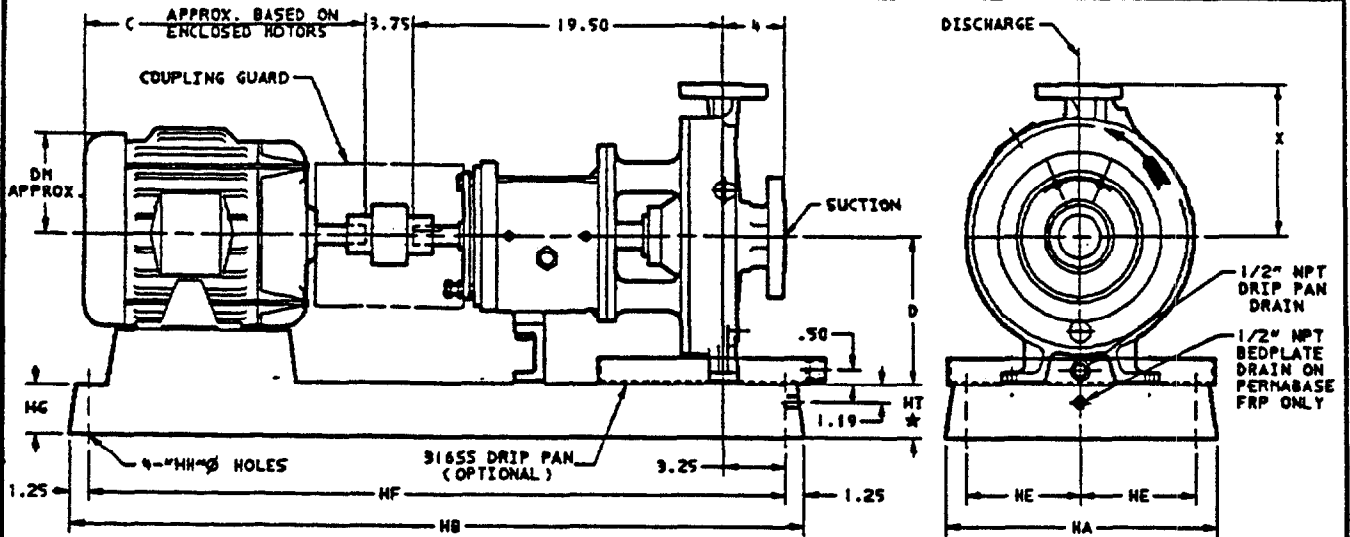

| MOTOR DIMENSIONS (TEFC) | | | | | |
|-------------------------|------|----|----|-----------------------|---------------|
| MOTORS NEMA | IEC | C | DM | WT. INCL. CPLG. | BDPLT. NO. |
| | | | | | |
| 143T | 90S | 13 | 4 | 40 | 1 |
| 145T | 90L | 14 | 4 | 45 | 1 |
| 182T | 100L | 15 | 5 | 65 | 1 |
| 184T | 112M | 16 | 5 | 75 | 1 |
| 213T | 132S | 18 | 6 | 150 | 1 |
| 215T | 132M | 20 | 6 | 160 | 1 |
| 254T | 160M | 23 | 7 | 255 | 2 |
| 256T | 160L | 24 | 7 | 280 | 2 |
| 284T | 180M | 26 | 8 | 375 | 2 |
| 284TS | --- | 25 | 8 | 345 | 2 |
| 286T | 180L | 27 | 8 | 430 | 2 |
| 286TS | --- | 26 | 8 | 380 | 2 |
| 324T | 200M | 29 | 9 | 575 | 3 |
| 324TS | --- | 27 | 9 | 485 | 3 |
| 326T | 200L | 30 | 9 | 640 | 3 |
| 326TS | --- | 29 | 9 | 570 | 3 |
| 364T | 225S | 33 | 10 | 810 | 3A |
| 364TS | --- | 31 | 10 | 755 | 3A |
| 365T | 225M | 34 | 10 | 950 | 3A |
| 365TS | --- | 32 | 10 | 865 | 3A |
| 404TS | --- | 34 | 11 | 1080 | 4 |
| 405TS | --- | 36 | 11 | 1110 | 4 |
| 444TS | --- | 39 | 13 | 1510 | 4A |

| BEDPLATE DIMENSIONS | | | | | | | | | | | | | |
|---------------------|----|----|-------------|------|-----------|------|-----------|------|------|-------|------|-----------|-----|
| NO. | HA | HB | HT (D=8.25) | | HT (D=10) | | HG | | HE | HF | HH | WEIGHT | |
| | | | CAST IRON | FRP | CAST IRON | FRP | CAST IRON | FRP | | | | CAST IRON | FRP |
| 1 | 12 | 45 | 9.75 | 9.94 | 3.75 | 3.94 | 9.75 | 3.62 | 4.50 | 42.50 | .75 | 105 | 44 |
| 2 | 15 | 52 | 4.12 | 4.31 | 4.12 | 4.31 | 4.12 | 4.00 | 6.00 | 49.50 | .75 | 155 | 56 |
| 3 | 18 | 58 | 4.75 | 5.06 | 4.75 | 5.06 | 4.75 | 4.75 | 7.50 | 55.50 | 1.00 | 205 | 77 |
| 3A | 18 | 58 | 5.75 | 6.06 | 4.75 | 5.06 | 4.75 | 4.75 | 7.50 | 55.50 | 1.00 | 205 | 77 |
| 4 | 18 | 60 | 6.75 | NA | 5.00 | NA | 4.75 | NA | 7.50 | 57.50 | 1.00 | 240 | NA |
| 4A | 18 | 60 | 7.75 | NA | 6.00 | NA | 4.75 | NA | 7.50 | 57.50 | 1.00 | 240 | NA |

| PUMP DIMENSIONS | | | | | | |
|-----------------|-------------|------------|--------------|-------|-------|------|
| ANSI DISCH. NO. | DISCH. SIZE | SUCT. SIZE | CASING CLASS | D | X | WGT. |
| 1 | 1 | 2 | 10 | 8.25 | 8.50 | 220 |
| 2 | 1 1/2 | 3 | 13 | 10.00 | 10.50 | 285 |

| |
|---|
| PUMP MODEL |
| <input checked="" type="checkbox"/> LF 3196 MTX |
| <input type="checkbox"/> LF 3196 LTX |
| AVAILABLE OPTIONS |
| BEDPLATE: |
| <input checked="" type="checkbox"/> CAST IRON |
| <input type="checkbox"/> PERMABASE™ FRP |
| <input type="checkbox"/> Y-BASE™ |
| 316SS DRIP PAN: |
| <input type="checkbox"/> FURNISHED |
| <input checked="" type="checkbox"/> NOT FURNISHED |
| FLANGES: |
| <input checked="" type="checkbox"/> 150# ANSI RAISED FACE |
| <input type="checkbox"/> 300# ANSI RAISED FACE |
| CPLG. GUARD FURNISHED BY: |
| <input checked="" type="checkbox"/> GOULDS |
| <input type="checkbox"/> OTHERS |

FOR TAPPED OPENINGS REFER TO DRAWING A05064A

INSTALL FOUNDATION BOLTS IN PIPE SLEEVES. ALLOW .75 TO 1.50 FOR GROUTING. SEE INSTRUCTION BOOK FOR DETAILS.

◆ 150# FLANGES NOT AVAILABLE ON 1 1/2 X 3 - 13 CASING

■ DISCHARGE FLANGE WILL BE THREADED. AS FOLLOWS:
 150# - 1 X 2 - 10 : 4-1/2-13 UNC-2B
 300# - 1 X 2 - 10 : 4-5/8-11 UNC-2B
 300# - 1 1/2 X 3 - 13 : 4-9/4-10 UNC-2B

◆ FOR LF 3196 LTX, ADD 20 LBS. TO PUMP GIVEN WEIGHT

★ TOLERANCE IS +.30 -0 FOR CAST IRON BEDPLATE.

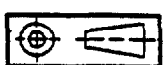

CERTIFIED FOR CONSTRUCTION PURPOSES ONLY WHEN SIGNED.

SIGNATURE *Joyce Sutterby* DATE 7-7-95

Goulds Serial #788D285
 Customer: OHM REMEDIATION SERVICES
 P.O. #1005430-1
 Item #P-245
 Service: REUSE WATER

| | | | | | |
|-------|--|----------------------------|--------------------|---------------|------------|
| ISSUE | DRAWING IS NOT TO SCALE DIMENSIONS IN INCHES WEIGHTS (LBS) ARE APPROXIMATE | DRAWN TEL 8-18-92 | DRAWING A05065A | REVISION 0 | ISSUE 0 |
| | | APPROVED DJC 9-30-92 | | | |



GOULDS PUMPS, INC.

INDUSTRIAL PRODUCTS GROUP
ENGINEERED PRODUCTS DIV.

PUMP TAPPED OPENINGS
MODEL LF 3196 MTX, LTX

TAPPED OPENINGS

| NO. | SIZE | QTY. | PURPOSE | FURNISHED | | NO. | SIZE | QTY. | PURPOSE | FURNISHED | |
|-----|------|------|-----------------------|-----------|----|-----|------|------|-------------------------|-----------|----|
| | | | | YES | NO | | | | | YES | NO |
| TB | 1/2 | 1 | CASING DRAIN | X | | TLI | --- | 2 | FRAME COOLER ACCESS | X | |
| TC | 1/2 | 1 | BY-PASS CONNECTION | | X | TN | 1/4 | 4 | GREASE FITTING | X | |
| TD | 3/8 | 1 | DISCHARGE GAUGE CONN. | X | | TN2 | 1/4 | 2 | OIL MIST INJECTION PORT | X | |
| TE | 3/8 | 1 | SUCTION GAUGE CONN. | | | TY | 1/2 | 1 | OIL FILL | X | |
| TF | 3/8 | 1 | BEARING FRAME DRAIN | X | | TZ | 1/4 | 1 | TRICO OILER CONNECTION | X | |
| TL | 1/2 | 2 | FRAME COOLING CONN. | | X | | | | | | |

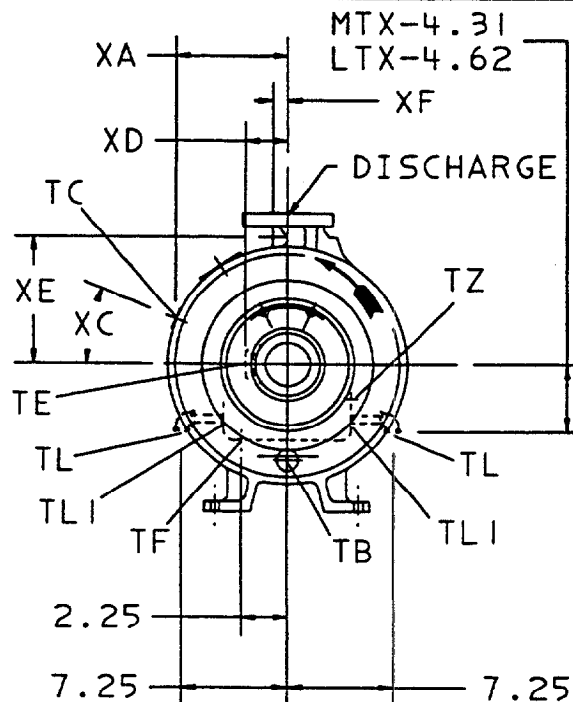
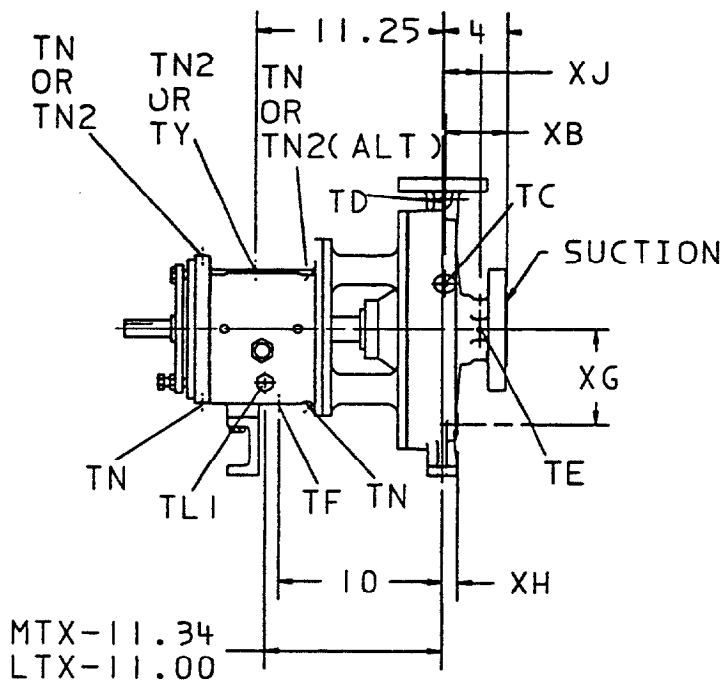

| PUMP DIMENSIONS | | | | | | | | | | |
|-----------------|------------|------|------|-------|------|------|------|------|------|------|
| ANSI NO. | SIZE | XA | XB | XC | XD | XE | XF | XG | XH | XJ |
| X A05 | 1X2-10 | 6.19 | 4.19 | 22.5° | 1.75 | 7.25 | 1.00 | 5.00 | .94 | 2.38 |
| A20 | 1 1/2X3-13 | 7.62 | 4.00 | 22.5° | 2.31 | 8.94 | 1.00 | 6.50 | 1.06 | 2.25 |

CERTIFIED FOR CONSTRUCTION PURPOSES ONLY WHEN SIGNED.

SIGNATURE *James Sutterby* DATE 7-7-95

PUMP MODEL

LF 3196 MTX
 LF 3196 LTX

Goulds Serial #788D285
Customer: OHM REMEDIATION SERVICES
P.O. #1005430-1
Item #P-245
Service: REUSE WATER

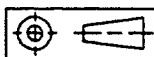

ISSUE

DRAWING IS NOT TO SCALE
DIMENSIONS IN INCHES

DRAWN TEL 8-18-92
APPROVED DJC 9-15-92

DRAWING
A05064A

REVISION
1

ISSUE
0



GOULDS PUMPS, INC.

INDUSTRIAL PRODUCTS GROUP
ENGINEERED PRODUCTS DIV.

PUMP TAPPED OPENINGS
GROUP-MTX/LTX

STUFFING BOX/SEAL CHAMBERS/DYNAMIC SEAL

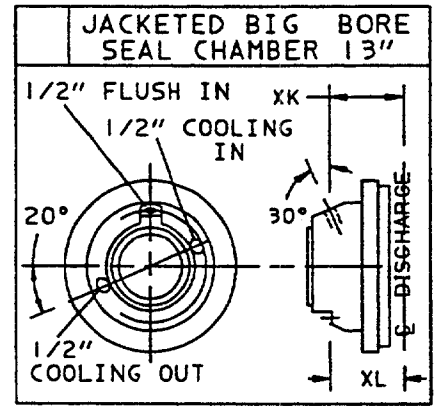
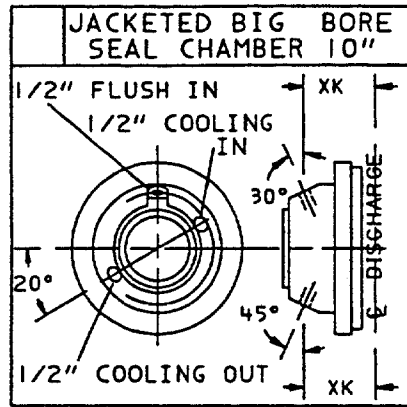
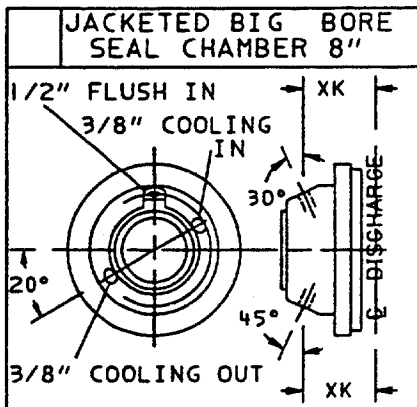
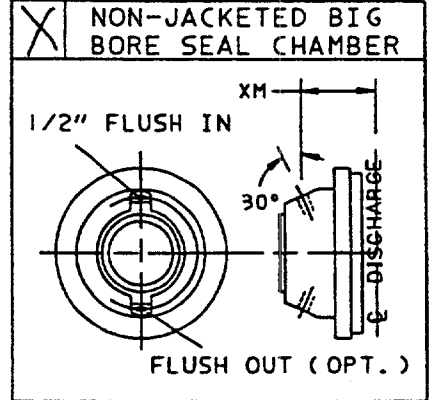
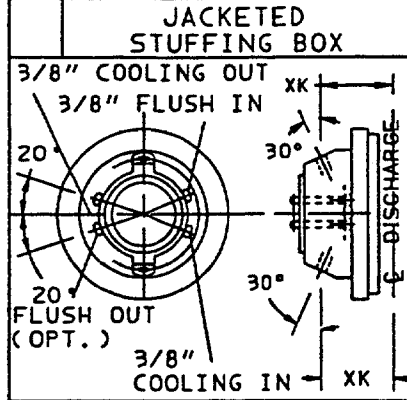
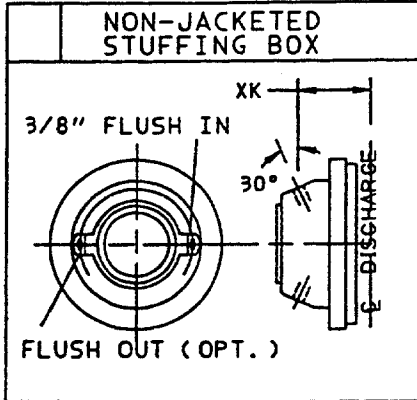

| PUMP MODEL | PUMP DIMENSIONS | | | |
|---|-----------------|--------------|-------|-------|
| | XK | (MAXIMUM) XJ | XL | XM |
| 3196 | 3.38 | 2.50 | 3.06 | 3.50 |
| 3796: | | | | |
| 2X2-10 | 5.50 | 4.81 | 5.19 | 5.62 |
| 3X3-10 | 6.38 | 5.69 | 6.06 | 6.50 |
| 4X4-10 | 7.12 | 6.44 | 6.81 | 7.25 |
| 3X3-13 | 6.38 | 5.69 | 6.06 | 6.50 |
| 4X4-13 | 7.12 | 6.44 | 6.81 | 7.25 |
| 6X6-13 | 11.50 | 10.81 | 11.19 | 11.62 |
| 3996 | 3.88 | 3.00 | 3.56 | 4.00 |
| <input checked="" type="checkbox"/> LF 3196 | 3.38 | 2.50 | 3.06 | 3.50 |
| CV 3196: | | | | |
| 2X2-10 | 5.50 | 4.81 | 5.38 | 5.62 |
| 3X3-10 | 6.19 | 5.69 | 6.06 | 6.31 |
| 2X3-13 | 6.00 | 5.69 | 5.88 | 6.19 |
| 3X4-13 | 6.50 | 6.44 | 6.06 | 6.69 |

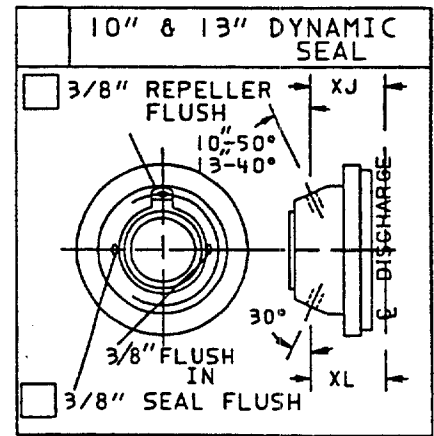

| GROUP | |
|-------------------------------------|-----|
| <input checked="" type="checkbox"/> | MTX |
| <input type="checkbox"/> | LTX |

NOTE: TAPPED OPENINGS NOT AVAILABLE ON TAPER BORE™ PLUS SEAL CHAMBERS

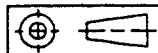

8" DYNAMIC SEAL IS NOT AVAILABLE

CERTIFIED FOR CONSTRUCTION PURPOSES ONLY WHEN SIGNED.

SIGNATURE *Joyce Sutterby* DATE 7-7-95

Goulds Serial #788D285
Customer: OHM REMEDIATION SERVICES
P.O. #1005430-1
Item #P-245
Service: REUSE WATER

ISSUE

DRAWING IS NOT TO SCALE
DIMENSIONS IN INCHES

DRAWN TJA
8-31-94
APPROVED PTH
9-6-94

DRAWING
A05461A

REVISION
0

ISSUE
0

**STUFFING BOX/SEAL CHAMBER GLAND OPTIONS
OPTION FURNISHED WHEN CHECKED**

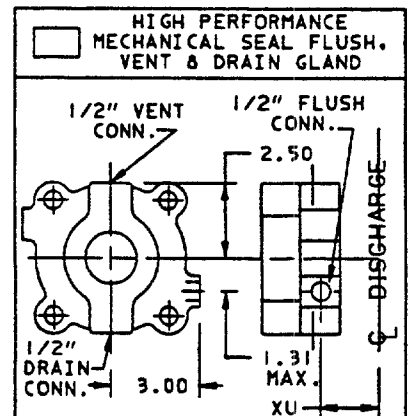
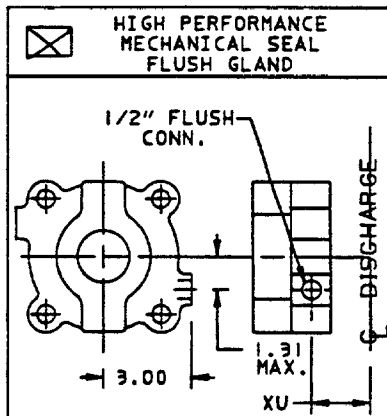
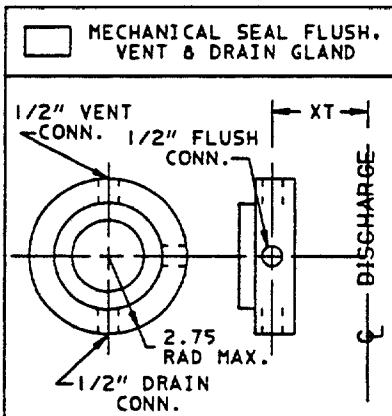
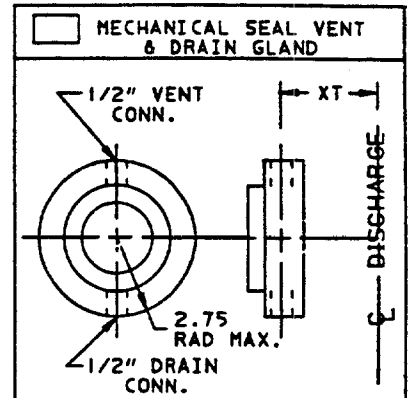
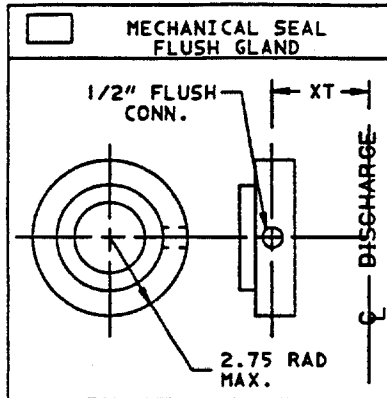
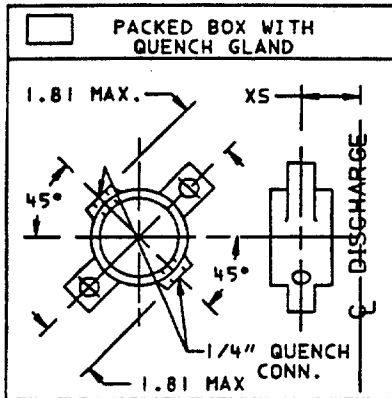

| PUMP MODEL | PUMP DIMENSIONS (MAXIMUM) | | | |
|---|------------------------------|-------|-------|--|
| | XS | XT | XU | |
| 3196 | 4.88 | 4.75 | 4.62 | |
| 3796: 2X2-10 | 7.12 | 7.00 | 6.81 | |
| 3X3-10 | 8.00 | 7.88 | 7.69 | |
| 4X4-10 | 8.75 | 8.62 | 8.44 | |
| 3X3-13 | 8.00 | 7.88 | 7.69 | |
| 4X4-13 | 8.75 | 8.62 | 8.44 | |
| 6X6-13 | 13.12 | 13.00 | 12.81 | |
| 3996 | 5.38 | 5.25 | 5.12 | |
| <input checked="" type="checkbox"/> LF 3196 | 4.88 | 4.75 | 4.62 | |
| CV 3196: 2X2-10 | 7.12 | 7.00 | 6.81 | |
| 3X3-10 | 7.81 | 7.69 | 7.52 | |
| 2X3-13 | 7.69 | 7.56 | 7.36 | |
| 3X4-13 | 8.19 | 8.06 | 7.86 | |

| GROUP | |
|-------------------------------------|-----|
| <input checked="" type="checkbox"/> | MTX |
| <input type="checkbox"/> | LTX |

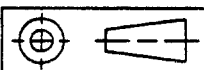

CERTIFIED FOR CONSTRUCTION PURPOSES ONLY WHEN SIGNED.

SIGNATURE *Joyce Sutterby* DATE 7-7-95

Goulds Serial #788D285
Customer: OHM REMEDIATION SERVICES
P.O. #1005430-1
Item #P-245
Service: REUSE WATER

| | | | | | |
|-------|---|-------------------------|--------------------|---------------|------------|
| ISSUE | DRAWING IS NOT TO SCALE DIMENSIONS IN INCHES | DRAWN TJA 09-01-94 | DRAWING A05469A | REVISION 0 | ISSUE 0 |
| | | CHECKED PTM 09-06-94 | | | |

Date 10-30-1992

Rev. Date

GOULDS PUMPS, INC.
Seneca Falls, NY 13148

CENTRIFUGAL PUMP CHARACTERISTICS

RPM 1750 CDS 4550

Model LF 3196 MTX/LTX

Size 1X2-10

Imp. Dwg. C03488A/C03491A

Pattern 68693

Eye Area 4.9 in²

9 1/8" IMP. DIA.

Goolds Serial #788D285
Customer: OHM REMEDIATION SERVICES
P.O. #1005430-1
Item #P-245
Service: REUSE WATER

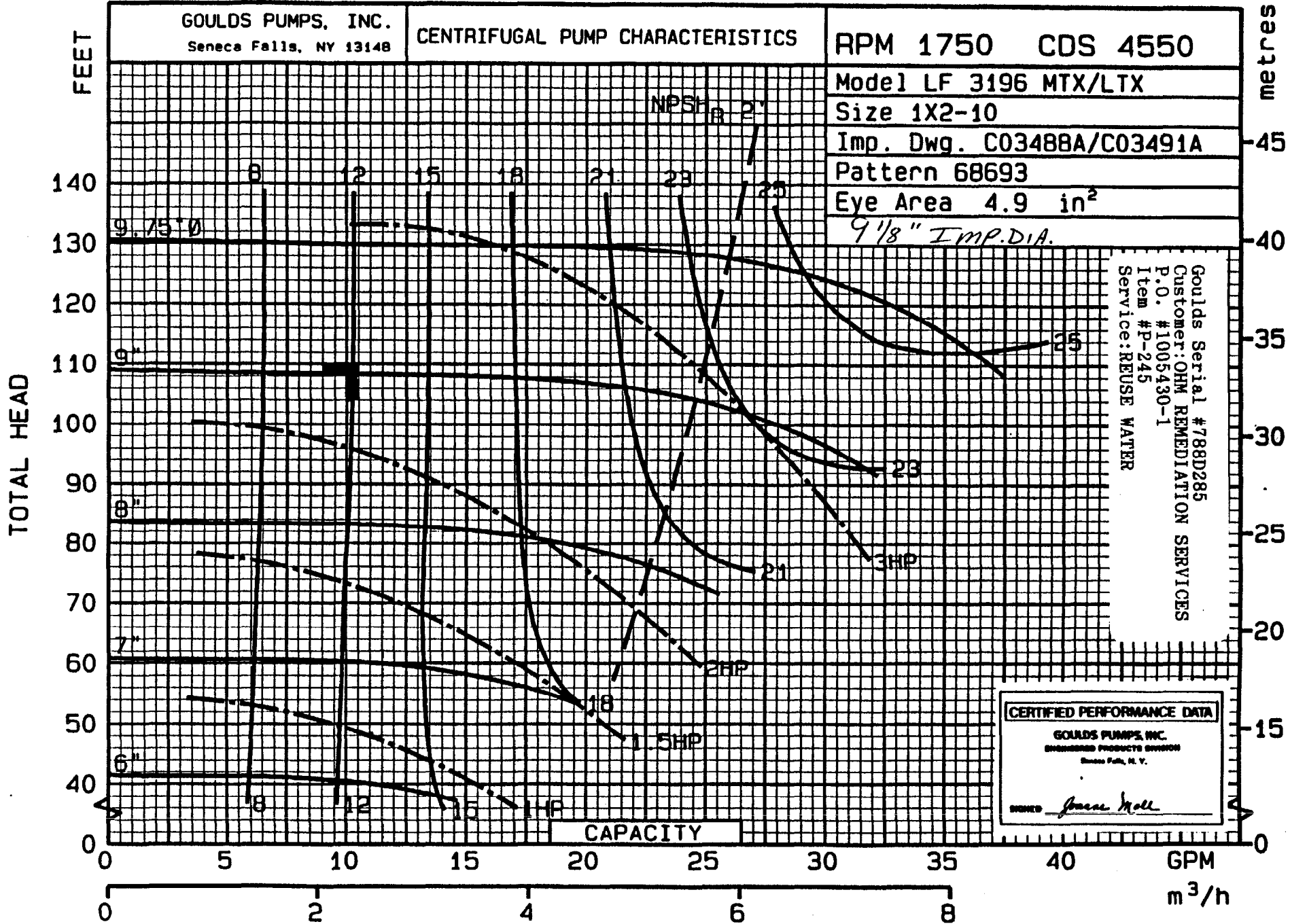

CERTIFIED PERFORMANCE DATA

GOULDS PUMPS, INC.
ENGINEERED PRODUCTS DIVISION
Seneca Falls, N. Y.

DATED *Jones Moll*

BILL OF MATERIAL
CONSTRUCTION: DUCTILE IRON W/ 316SS

STANDARD OIL LUBE

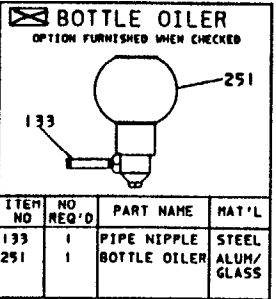

| ITEM NO | QTY PER PUMP | PART NAME | MATERIAL |
|---------|--------------|-------------------------|-----------|
| 100 | 1 | CASING | DI |
| 101 | 1 | IMPELLER | 316SS |
| 105 | 2 | LANTERN RING HALF | TEFLON |
| 106 | 1 | STUFFING BOX RKG | NON-ASB |
| 107 | 1 | GLAND | 316SS |
| 108 | 1 | FRAME ADAPTER | DI |
| 112A | 1 | BALL BRG OTBD | STEEL |
| 113A | 1 | PLUG,OIL FILL | STEEL |
| 122 | 1 | SHAFT | STEEL |
| 126 | 1 | SHAFT SLEEVE | 316SS |
| 134 | 1 | BRG HOUSING | CI |
| 136 | 1 | BRG LOCK NUT | STEEL |
| 168A | 1 | BALL BRG INBD | STEEL |
| 184 | 1 | S.B. COVER/SEAL CHAM. | DI |
| 228 | 1 | FRAME | CI |
| 241 | 1 | FRAME FOOT | CI |
| 250 | 1 | GLAND, MECH. SEAL | 316SS |
| 319 | 1 | SIGHT GLASS | STL/GLASS |
| 332A | 1 | LBYR SEAL OTBD W/O-RING | TFL/GPH |
| 333A | 1 | LBYR SEAL INBD W/O-RING | TFL/GPH |
| 351 | 1 | GASKET-CASE | EPDM-RBR |
| 353 | 2 | STUD-GLAND | 316SS |
| 355 | 2 | NUT GLAND STUD | 304SS |
| 360D | 1 | GASKET-FR-ADPTR | VELLUMOID |
| 361A | 1 | RTNG RING-BRG HSG | STEEL |
| 370 | 8 | H CAP SCR-ADPTR-CASE | STEEL |
| 370B | 4 | H CAP SCR-ADPTR-FR | STEEL |
| 370C | 3 | H TAP BOLT-BRG HSG | STEEL |
| 370D | 3 | H TAP BOLT-IMPLR-ADJ | STEEL |
| 370F | 2 | H CAP SCR-FR-FOOT | STEEL |
| 370H | 2 | STUD-COVER-ADPTR | 304SS |
| 382 | 1 | BRG LOCKWASHER | STEEL |
| 400 | 1 | KEY,SQUARE | STEEL |
| 408A | 1 | MAG. PLUG-OIL DRAIN | STEEL |
| 408J | 1 | PLUG,SIGHT OILER | STEEL |
| 408H | 4 | PLUG,OIL MIST CONN | STEEL |
| 412A | 1 | O-RING IMPELLER | TEFLON |
| 418 | 3 | H TAP BOLT-JACKING | 304SS |
| 423 | 3 | JAM NUT FOR 370D | STEEL |
| 469B | 2 | DOWEL PIN-FR-ADPTR | ALLOY-ST |
| 496 | 1 | O-RING-BRG HSG | BUNA-RBR |
| 497F | 1 | O-RING,OTBD SEAL ROT. | VITON |
| 497G | 1 | O-RING,OTBD SEAL STA. | VITON |
| 497H | 1 | O-RING,INBD SEAL ROT. | VITON |
| 497J | 1 | O-RING,INBD SEAL STA. | VITON |

- * RECOMMENDED SPARE PARTS
- Ⓐ ITEM 370 IS QTY 12 FOR 10" CASINGS & QTY 16 FOR 13" CASINGS.
- Ⓑ GLAND BOLTING FOR PACKING GLAND (ITEM 353 & 355) IS QTY 2, FOR MECHANICAL SEAL QTY 4.
- Ⓒ ITEMS NOT ILLUSTRATED.

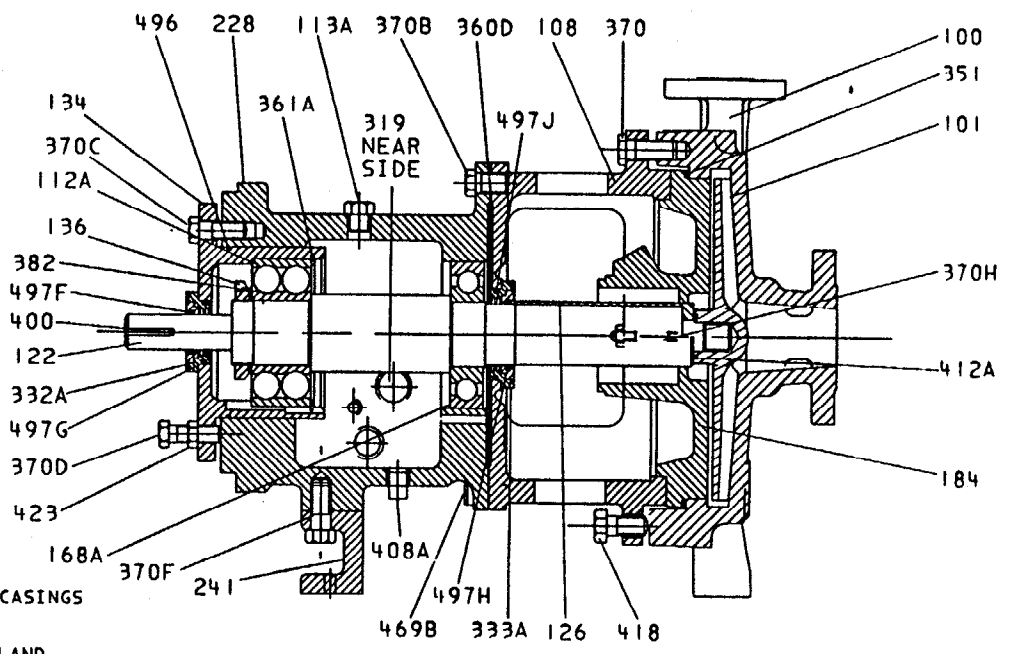

STUFFING BOX COVER / SEAL CHAMBER OPTIONS - CHECK OPTION REQUIRED

STUFFING BOX

NONJACKETED (SHOWN)

JACKETED

REFER TO SEAL DRAWING NO. 265-248801

ATTACHED

TO FOLLOW

TAPER BORE™ PLUS

BIG BORE™ STD. FLUSH

NONJACKETED (SHOWN)

JACKETED

BIG BORE™ W/ INTERNAL BY-PASS

Goulds Serial #788D285
Customer:OHM REMEDIATION SERVICES
P.O. #1005430-1
Item #P-245
Service:REUSE WATER

PUMP CROSS SECTION DRAWING
MODEL LF 3196 MTX

GOULDS PUMPS, INC.
INDUSTRIAL PRODUCTS GROUP
ENGINEERED PRODUCTS DIV.

| | | | |
|--------------------------|----------------------------|-----------------------------|---------------------------|
| DRAWN DLD 08/13/92 | CHECKED TEL 08/13/92 | APPROVED DJC 08/13/92 | THIRD ANGLE PROJECTION |
| DRAWING IS NOT TO SCALE | | | DRAWING B02384A2 |
| | | | REV. 1 |

Goulds Serial #788D285
 Customer: OHM REMEDIATION SERVICES
 P.O. #1005430-1
 Item #P-245
 Service: REUSE WATER

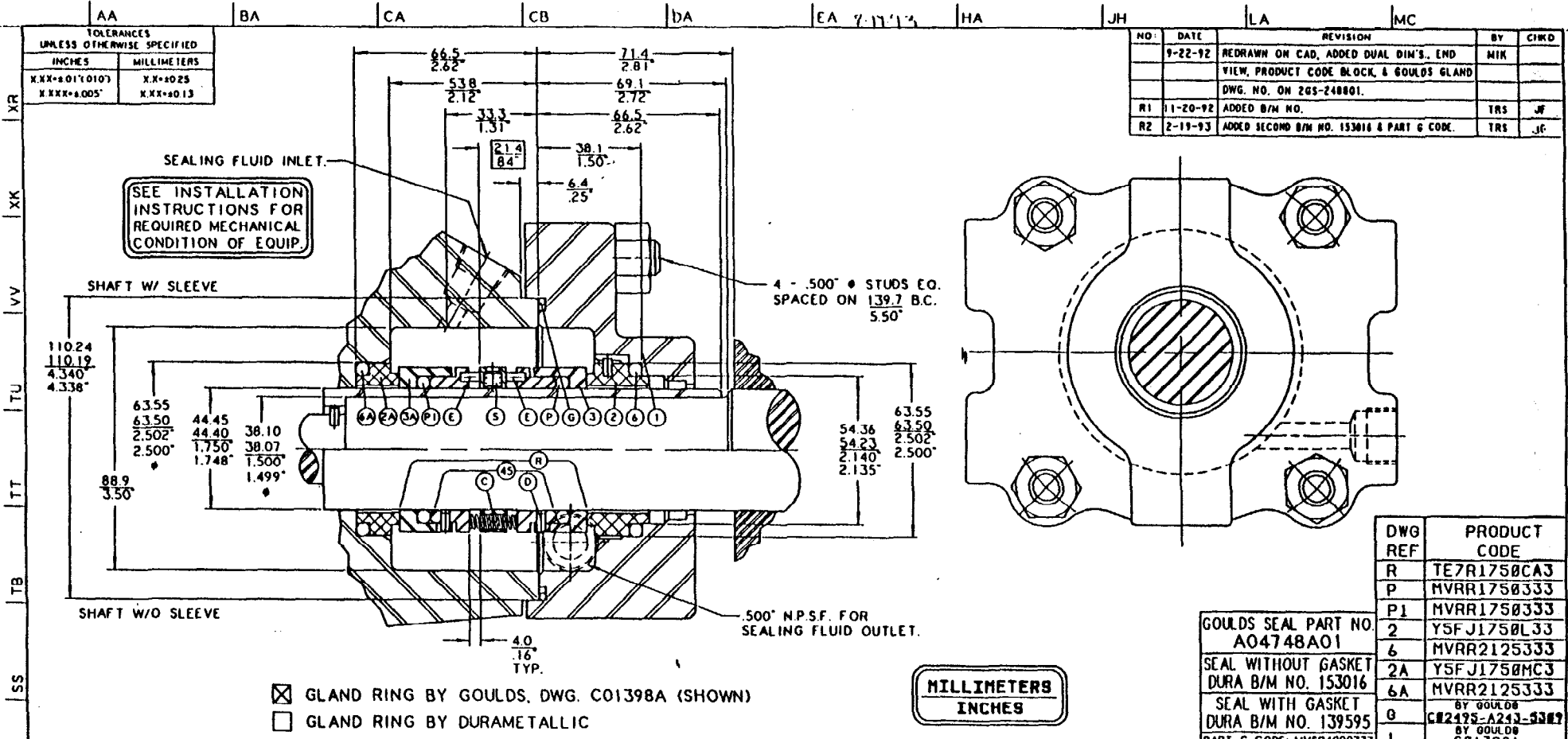

| NO. | DATE | REVISION | BY | CHKD |
|---------|----------|--|-----|------|
| 9-22-92 | | REDRAWN ON CAD, ADDED DUAL DIM'S, END VIEW, PRODUCT CODE BLOCK, & GOULDS GLAND | NIK | |
| | | DWG. NO. ON 2GS-248801. | | |
| R1 | 11-20-92 | ADDED B/M NO. | TRS | JF |
| R2 | 2-19-93 | ADDED SECOND B/M NO. 153016 & PART G CODE. | TRS | JF |

| DWG REF | PRODUCT CODE |
|---------|-------------------------------|
| R | TE7R1750CA3 |
| P | MVRR1750333 |
| P1 | MVRR1750333 |
| 2 | Y5FJ1750L33 |
| 6 | MVRR2125333 |
| 2A | Y5FJ1750MC3 |
| 6A | MVRR2125333 |
| 0 | BY GOULDS C82475-A243-5317 |
| 1 | BY GOULDS C81398A |

GOULDS SEAL PART NO. AO4748A01
 SEAL WITHOUT GASKET DURA B/M NO. 153016
 SEAL WITH GASKET DURA B/M NO. 139595
 PART G CODE: MYSR4000333

| R | ROTARY UNIT CONSISTING OF: | P | SHAFT PKG. | VITON |
|----|----------------------------|----|-------------|--------------|
| 3 | SEAL RING TUNCAR 62-6 | P1 | SHAFT PKG. | VITON 1 |
| 3 | SEAL RING TUNCAR 62-6 | 2 | INSERT | NO. 5 CARBON |
| 45 | COMP. UNIT 316 SS | 6 | INSERT MTG. | VITON |
| C | SPRINGS 20 SS | 2A | INSERT | NO. 5 CARBON |
| D | DRIVE PINS 20 SS | 6A | INSERT MTG. | VITON |
| E | SPRING PINS 20 SS | G | GASKET | NON-ASB |
| S | SET SCREWS 20 SS | 1 | GLAND RING | 316SS |

| | |
|--|---------------------|
| CUSTOMER: GOULDS PUMPS, INC., SENECA FALLS, NY | |
| P.O. NO.: | F.O.NO.: |
| USER: | |
| EQUIP. TYPE & SIZE | EQUIP. SERIAL NO. |
| GOULDS 3196 MT & MTX ANSI PLUS PUMPS | 788D285 |
| | EQUIP. ITEM NO.: |
| | REFERENCE DWG. NO.: |
| | C01391A |
| PRODUCT | PRESSURES |
| WATER | |
| TEMP: 80°F | BOX: |
| RPM: 1800 | SUCT.: |
| SPGR: 1.00 | DISCH.: |

| | | |
|--------------------------|----------------------------------|--------------|
| DURA SEAL TYPE | | SEAL SIZE |
| DOUBLE INSIDE RO | | 1.750" |
| DURAMETALLIC CORPORATION | | |
| KALAMAZOO, MICHIGAN | | |
| MATL CODE | E | LL 5 - - V V |
| SCALE: .72" = 1.00" | ORDER PARTS BY B/M NO. SEE ABOVE | |
| DATE: 4-29-89 | DATE: 9-28-92 | |
| OWN: TC | CHKD: GB | DWN: PGP |
| APPROB.: | CHKD: GB | |
| FORM DWG: | DWG. NO.: | |
| 2GS-248801 | 788285 #3 | |

RECOMMENDED SPARE PARTS: 2, 2A, 3, 3A, 6, 6A, C, G, P, PI, S



GOULDS PUMPS, INC.
ENGINEERED PRODUCTS DIVISION

LUBRICANT DATA SHEET

CUSTOMER INFORMATION

EQUIPMENT IDENTIFICATION

Goulds Serial #788D285
Customer: OHM REMEDIATION SERVICES
P.O. #1005430-1
Item #P-245
Service: REUSE WATER

MODEL LF 3196MTX SIZE 1X2-10
LUBRICATION OIL
CONST. DI/316SS

| PART LUBRICATED | LUBRICANT | | FILL CAPACITY | CONSUMPT. AMT. / TIME | RECOMMENDED LUBRICANT MFR. & NO. & REMARKS |
|-----------------------|------------------|------------|---------------------------|---|--|
| | TYPE | VISC OSITY | | | |
| BEARING HOUSING FRAME | TURBINE TYPE OIL | ISO VG68 | APPROX. 2.6 PTS (1250 ML) | REFILL APPROXIMATELY EVERY(3) MONTHS OR 2000 HRS. | OIL MUST BE VISIBLE AT CENTER OF SIGHT GLASS |

REV. DATE

| | | | | | |
|--|--|------------|-------------|-------------|------|
| | | WRITTEN BY | APPROVED BY | DRAWING NO. | REV. |
| | | DATE | DATE | 196 MTX LDS | 0 |

SHEET 1 OF 1



TYPE SC SPACER COUPLINGS

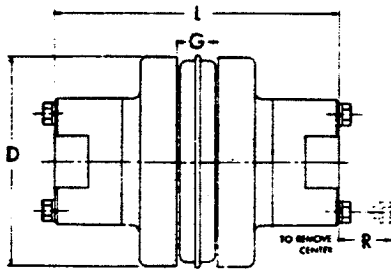
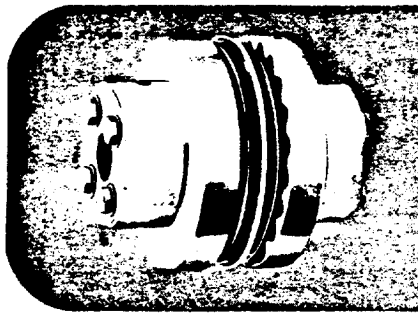

The table below shows assembled dimensions of Sure-Flex Type SC Spacer Couplings. For dimensions of separate components, refer to page 19.

Goulds Serial #788D285
 Customer: OHM REMEDIATION SERVICES
 P.O. #1005430-1
 Item #P-245
 Service: REUSE WATER

| Coupling Size | Required Distance Between Shafts | Use Flange No. | Use Hub No. | Max. Bore Std. KS | Dimensions | | | | Wt. ⁽²⁾ (lbs.) |
|---------------|----------------------------------|----------------|-------------|----------------------|------------|------------------|--------|--------|---------------------------|
| | | | | | D | L ⁽¹⁾ | G | R | |
| 4JSC | 3 1/2 | 4JSC35 | | 1 1/2 ⁽¹⁾ | 2.460 | 5 1/2 | 5/8 | | 2.7 |
| 5SC | 3 1/2 | 5SC35 | 5H | 1 1/2 | 3.250 | 5 1/2 | 3/4 | 3/16 | 4.5 |
| 6SC | 3 1/2 | 6SC35 | 6H | 1 1/2 | 4.000 | 5 1/2 | 7/8 | 3/16 | 7.3 |
| | 4 1/2 | 6SC44 | 6H | 1 1/2 | 4.000 | 6 1/2 | 7/8 | 3/16 | 8.1 |
| 7SC | 5 | 6SC50 | 6H | 1 1/2 | 4.000 | 7 1/2 | 7/8 | 3/16 | 8.7 |
| | 3 1/2 | 7SC35 | 7H | 1 1/2 | 4.625 | 6 1/2 | 1 | 5/8 | 9.9 |
| | 4 1/2 | 7SC44 | 7H | 1 1/2 | 4.625 | 7 1/2 | 1 | 5/8 | 10.8 |
| 8SC | 5 | 7SC50 | 7H | 1 1/2 | 4.625 | 7 1/2 | 1 | 5/8 | 11.4 |
| | 3 1/2 | 8SC35 | 8H | 1 1/2 | 5.450 | 6 1/2 | 1 1/8 | 1 1/16 | 15.2 |
| | 4 1/2 | 8SC35-10 | 10H* | 2 1/2 | 5.450 | 8 1/2 | 1 1/8 | 1 1/16 | 23.2 |
| 9SC | 4 1/2 | 8SC44 | 8H | 1 1/2 | 5.450 | 7 1/2 | 1 1/8 | 1 1/16 | 16.4 |
| | 5 | 8SC50 | 8H | 1 1/2 | 5.450 | 8 1/2 | 1 1/8 | 1 1/16 | 17.4 |
| | 5 | 8SC50-10 | 10H* | 2 1/2 | 5.450 | 9 1/2 | 1 1/8 | 1 1/16 | 27.2 |
| | 3 1/2 | 9SC35 | 9H* | 2 1/2 | 6.350 | 7 1/2 | 1 1/16 | 1 1/16 | 18.6 |
| 10SC | 4 1/2 | 9SC44 | 9H* | 2 1/2 | 6.350 | 8 1/2 | 1 1/16 | 1 1/16 | 22.2 |
| | 5 | 9SC50 | 9H* | 2 1/2 | 6.350 | 8 1/2 | 1 1/16 | 1 1/16 | 23.2 |
| | 5 | 9SC50-11 | 11H* | 2 1/2 | 6.350 | 10 1/2 | 1 1/16 | 1 1/16 | 40.4 |
| | 7 | 9SC70-11 | 11H* | 2 1/2 | 6.350 | 12 1/2 | 1 1/16 | 1 1/16 | 48.2 |
| | 7 1/2 | 9SC78-11 | 11H* | 2 1/2 | 6.350 | 13 1/2 | 1 1/16 | 1 1/16 | 51.0 |
| 11SC | 4 1/2 | 10SC48 | 10H* | 2 1/2 | 7.500 | 9 1/2 | 1 1/2 | 1 3/16 | 37.6 |
| | 5 | 10SC50 | 10H* | 2 1/2 | 7.500 | 9 1/2 | 1 1/2 | 1 3/16 | 38.4 |
| | 7 | 10SC70-13 | 13H* | 3 1/2 | 7.500 | 13 1/2 | 1 1/2 | 1 3/16 | 72.0 |
| | 7 1/2 | 10SC78-13 | 13H* | 3 1/2 | 7.500 | 14 1/2 | 1 1/2 | 1 3/16 | 76.0 |
| 12SC | 10 | 10SC100-13 | 13H* | 3 1/2 | 7.500 | 16 1/2 | 1 1/2 | 1 3/16 | 88.0 |
| | 4 1/2 | 11SC48 | 11H* | 2 1/2 | 8.625 | 10 1/2 | 1 1/2 | 1 3/16 | 54.5 |
| | 5 | 11SC50 | 11H* | 2 1/2 | 8.625 | 10 1/2 | 1 1/2 | 1 3/16 | 54.7 |
| | 7 | 11SC70-14 | 14H | 3 1/2 | 8.625 | 14 1/2 | 1 1/2 | 2 | 86.1 |
| 13SC | 7 1/2 | 11SC78-14 | 14H | 3 1/2 | 8.625 | 15 1/2 | 1 1/2 | 2 | 90.3 |
| | 10 | 11SC100-14 | 14H | 3 1/2 | 8.625 | 17 1/2 | 1 1/2 | 2 | 102.7 |
| | 7 | 12SC70 | 12H* | 2 1/2 | 10.000 | 12 1/2 | 2 1/2 | 1 1/2 | 88.1 |
| | 7 | 12SC70-14 | 14H | 3 1/2 | 10.000 | 14 1/2 | 2 1/2 | 2 | 99.1 |
| 14SC | 7 1/2 | 12SC78 | 12H* | 2 1/2 | 10.000 | 13 1/2 | 2 1/2 | 1 1/2 | 91.9 |
| | 7 1/2 | 12SC78-14 | 14H | 3 1/2 | 10.000 | 15 1/2 | 2 1/2 | 2 | 103.3 |
| | 10 | 12SC100-14 | 14H | 3 1/2 | 10.000 | 17 1/2 | 2 1/2 | 2 | 115.7 |
| 13SC | 7 1/2 | 13SC78 | 13H* | 3 1/2 | 11.750 | 14 1/2 | 2 1/2 | 1 1/2 | 129.6 |
| 14SC | 7 1/2 | 14SC78 | 14H | 3 1/2 | 13.875 | 15 1/2 | 3 1/4 | 2 | 179.9 |

*Short (HS) hub also available. ■ Approximate weight for completely assembled spacer coupling.
 (1) 4JSC35 x 1 1/2 has shallow keyseat. (2) "L" dimension and weight will change if one or two short (HS) hubs used.
 Note: Refer to page 19 to order — specify components separately.

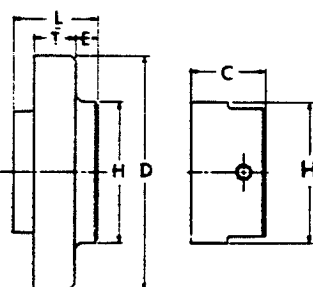
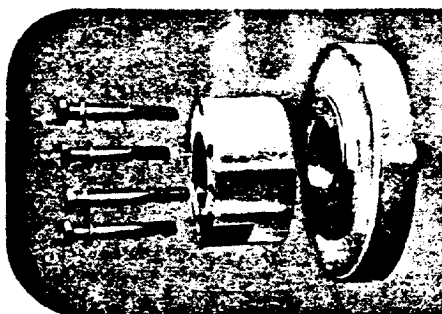

TYPE SC FLANGES AND HUBS

Tables on page 19 provide dimensional information for flanges and hubs used for Spacer Couplings. For assembled dimensions, see table above. Any of the sleeves shown on page 10 may be used.



GOULDS PUMPS, INC.
INDUSTRIAL PRODUCTS GROUP



GOULDS PUMPS

Installation, Operation and Maintenance Instructions

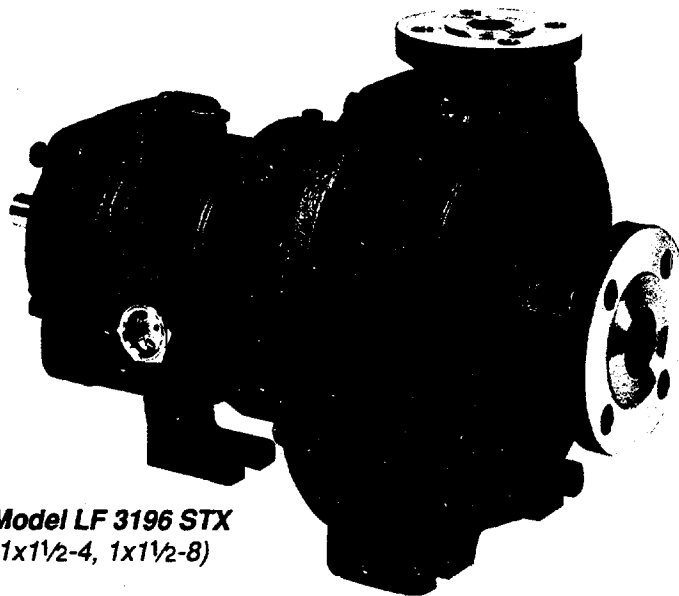

Model LF 3196 STX
(1x1½-4, 1x1½-8)

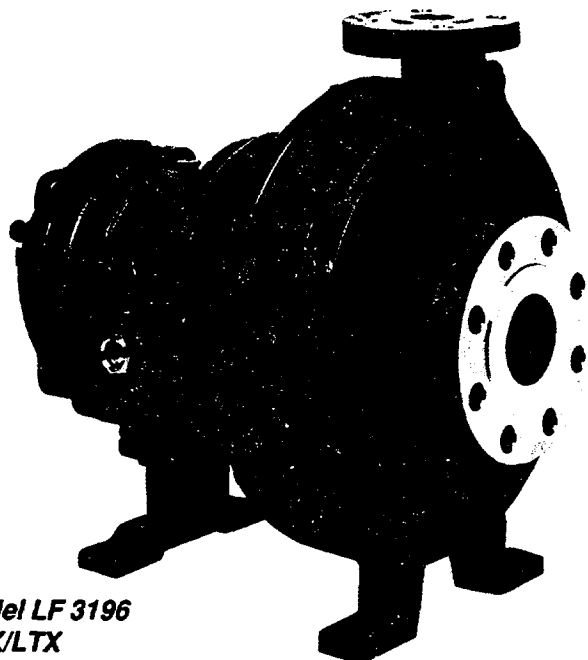

Model LF 3196
MTX/LTX
(1x2-10 MTX/LTX
1½x3-13 LTX)

Model LF 3196

FOREWORD

This manual provides instructions for the Installation, Operation, and Maintenance of the Goulds Model LF 3196 *Low Flow* ANSI Process Pump. This manual covers the standard product plus common options that are available. For special options, supplemental instructions are supplied. **This manual must be read and understood before installation and start-up.**

The design, materials, and workmanship incorporated in the construction of Goulds pumps makes them capable of giving long, trouble-free service. The life and satisfactory service of any mechanical unit, however, is enhanced and extended by correct application, proper installation, periodic inspection, condition monitoring and careful maintenance. This instruction manual was prepared to assist operators in understanding the construction and the correct methods of installing, operating, and maintaining these pumps.

Goulds shall not be liable for physical injury, damage or delays caused by a failure to observe the instructions for Installation, Operation, and Maintenance contained in this manual.

Warranty is valid only when genuine Goulds parts are used.

Use of the equipment on a service other than stated in the order will nullify the warranty, unless written approval is obtained in advance from Goulds Pumps, Inc.

Supervision by an authorized Goulds representative is recommended to assure proper installation.

Additional manuals can be obtained by contacting your local Goulds representative or by calling 1-800-446-8537.

THIS MANUAL EXPLAINS

- **Proper Installation**
- **Start-up Procedures**
- **Operation Procedures**
- **Routine Maintenance**
- **Pump Overhaul**
- **Trouble Shooting**
- **Ordering Spare or Repair Parts**

TABLE OF CONTENTS

| Page | | SECTION |
|-------------|-------------------------------------|----------------|
| 7 | SAFETY | 1 |
| 9 | GENERAL INFORMATION | 2 |
| 13 | INSTALLATION | 3 |
| 21 | OPERATION | 4 |
| 27 | PREVENTIVE MAINTENANCE | 5 |
| 35 | DISASSEMBLY & REASSEMBLY | 6 |
| 71 | SPARE AND REPAIR PARTS | 7 |
| 75 | APPENDIX | 8 |

SAFETY

| | |
|-------------------------------|---|
| DEFINITIONS | 7 |
| GENERAL PRECAUTIONS | 7 |

DEFINITIONS

This pump has been designed for safe and reliable operation when properly used and maintained in accordance with instructions contained in this manual. A pump is a pressure containing device with rotating parts that can be hazardous. Operators and maintenance personnel must realize this and follow safety measures. Goulds Pumps Inc. shall not be liable for physical injury, damage or delays caused by a failure to observe the instructions in this manual.

Throughout this manual the words **Warning**, **Caution**, and **Note** are used to indicate procedures or situations which require special operator attention:

WARNING

Operating procedure, practice, etc. which, if not correctly followed, could result in personal injury or loss of life.

CAUTION

Operating procedure, practice, etc. which, if not followed, could result in damage or destruction of equipment.

NOTE: Operating procedure, condition, etc. which is essential to observe.

EXAMPLES

WARNING

Pump shall never be operated without coupling guard installed correctly.

CAUTION

Throttling flow from the suction side may cause cavitation and pump damage.

NOTE: Proper alignment is essential for long pump life.

GENERAL PRECAUTIONS

WARNING

Personal injuries will result if procedures outlined in this manual are not followed.

- Never apply heat to remove impeller. It may explode due to trapped liquid.
- Never use heat to disassemble pump due to risk of explosion from trapped liquid.
- Never operate pump without coupling guard correctly installed.
- Never operate pump beyond the rated conditions to which the pump was sold.

- Never start pump without proper prime (sufficient liquid in pump casing).
- Never run pump below recommended minimum flow or when dry.
- Always lock out power to the driver before performing pump maintenance.
- Never operate pump without safety devices installed.
- Never operate pump with discharge valve closed.
- Never operate pump with suction valve closed.
- Do not change conditions of service without approval of an authorized Goulds representative.

GENERAL INFORMATION

| | |
|------------------------------------|-----------|
| PUMP DESCRIPTION | 9 |
| NAMEPLATE INFORMATION | 10 |
| RECEIVING THE PUMP | 11 |
| Storage Requirements | 11 |
| Handling | 11 |

PUMP DESCRIPTION

The Model LF 3196 is a horizontal overhung, open impeller centrifugal pump that meets requirements of ANSI B73.1.

The model is based on 3 power ends and 4 hydraulic pump sizes. Groupings are as follows:

| | |
|-----|--------------|
| STX | 2 pump sizes |
| MTX | 1 pump size |
| LTX | 1 pump size |

Casing - The casing is top centerline discharge and self-venting. The gasket is fully confined. An integral foot support is used for maximum resistance to misalignment and distortion from piping loads. ANSI class 150 raised face serrated flanges are standard on 4, 8 and 10" sizes. ANSI class 300 raised face serrated flanges are standard on 13" size, optional on 4, 8 and 10" sizes.

Impeller - The impeller is fully open has radial vanes and is threaded to the shaft. The threads are sealed from the pumpage by a Teflon O-ring.

Seal Chamber/Stuffing-Box Cover - The LF 3196 is available with a stuffing box cover designed for packing and BigBore™ seal chamber or TaperBore™ seal chamber for improved performance of mechanical seals.

Frame Adapter - The ductile iron frame adapter has machined rabbet fit to the seal chamber/stuffing box cover and precision dowel pin fit to the bearing frame.

Power End - Oil level is viewed through a sight glass. Optional oil cooling is provided by a finned tube. Flood oil lube is standard. The power end is sealed with Goulds designed labyrinth seals. No machining is required to convert from oil to grease or oil mist. Regreaseable bearings, greased-for-life bearings and oil mist lubrication are optional.

Shaft - The shaft is available with or without sleeve.

Bearings - The inboard bearing carries only radial load, it is free to float axially in the frame. The outboard bearing is shouldered and locked to the shaft and housing to enable it to carry radial and thrust loads. All fits are precision machined to industry standards. The inboard bearing is a single row deep groove ball bearing. The outboard bearing is a double row angular contact bearing, except for the LTX which uses a pair of single row angular contact ball bearings mounted back to back.

Dynamic Seal - A dynamic seal is available which uses a repeller to pump liquid out of the stuffing box while the pump operates, a static seal prevents leakage when the pump is shut down.

Direction of Rotation - Clockwise (right hand) as viewed from the driver, looking at the pump shaft.

NAMEPLATE INFORMATION

GOULDS PUMPS, INC. SENECA FALLS, N.Y.
MADE IN USA

IMPLR. DIA. MAX. DIA.

GPM FT HD RPM

MOD. SIZE

STD. NO. MAT L. CONSTR.

SER. NO. MAX. DSGN. PSI @ 100F

CAUTION: AFTER STARTING DO NOT OPERATE AGAINST CLOSED VALVE

Fig. 1

Every pump has two Goulds nameplates that provide information about the pump. The tags are located on the casing and bearing frame.

Pump Casing Tag - provides information about the pump's hydraulic characteristics. Note the format of the pump size: Discharge x Suction - Nominal maximum Impeller Diameter in inches.

(Example: 1x1½-4)(Fig. 1)

Bearing Frame Tag - provides information on the lubrication system used. (Fig. 2).

When ordering spare parts you will need to identify pump model, size, serial number, and the item number of required parts. Information can be taken from the pump casing tag. Item numbers can be found in this manual.

GOULDS PUMPS INC.

MOD. SENECA FALLS, N.Y.
MADE IN USA

SIZE

SER. NO.

LUBE

Fig. 2

RECEIVING THE PUMP

Inspect the pump as soon as it is received. Carefully check that everything is in good order. Make notes of damaged or missing items on the receipt and freight bill. File any claims with the transportation company as soon as possible.

STORAGE REQUIREMENTS

Short Term: (Less than 6 months) Goulds normal packaging procedure is designed to protect pump during shipping. Upon receipt store in a covered and dry location.

Long Term: (More than 6 months) Preservative treatment of bearings and machined surfaces will be required. Rotate shaft several times every 3 months. Refer to driver and coupling manufacturers for their long term storage procedures. Store in a covered dry location.

NOTE: Long term storage treatment can be purchased with initial pump order.

HANDLING

WARNING

Pump and components are heavy. Failure to properly lift and support equipment could result in serious physical injury, or damage to pumps.

Use care when moving pumps. Lifting equipment must be able to adequately support the entire assembly. Hoist bare pump using a suitable sling, under the suction flange and bearing frame. Baseplate mounted units are moved with slings under the pump casing and driver. Refer to Figs. 3A,B,C for examples of proper lifting techniques.

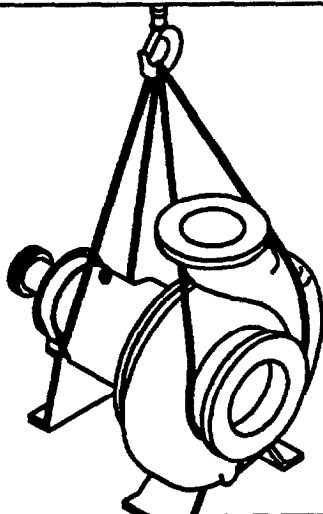

Fig. 3A

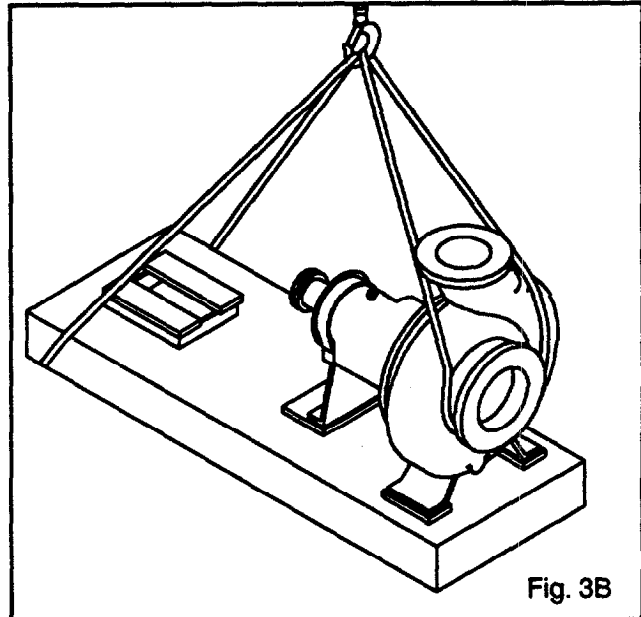

Fig. 3B

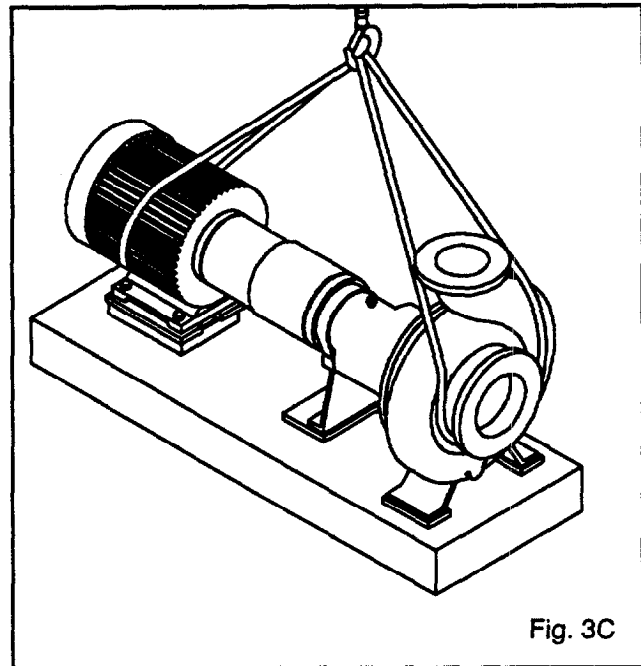

Fig. 3C

INSTALLATION

| | |
|--|-----------|
| SITE/FOUNDATION | 13 |
| LEVEL BASEPLATE | 14 |
| ALIGNMENT AND ALIGNMENT PROCEDURE | 14 |
| Alignment Check | 14 |
| Alignment Criteria | 15 |
| Set Up | 15 |
| Measurement | 15 |
| Angular Alignment | 16 |
| Parallel Alignment | 16 |
| Complete Alignment | 17 |
| Alignment Trouble Shooting | 17 |
| GROUT BASEPLATE | 18 |
| Alignment Check | 18 |
| PIPING | 18 |
| General | 18 |
| Suction Piping | 19 |
| Discharge Piping | 19 |
| Final Piping Check | 19 |

SITE/FOUNDATION

A pump should be located near the supply of liquid and have adequate space for operation, maintenance, and inspection.

Baseplate mounted pumps are normally grouted on a concrete foundation, which has been poured on a solid footing. The foundation must be able to absorb any vibration and to form a permanent, rigid support for the pumping unit.

The location and size of the foundation bolts are shown on outline assembly drawing, provided with the pump data package.

Foundation bolts commonly used are sleeve type (Fig. 4A) and J type (Fig. 4B). Both designs permit movement for final bolt adjustment.

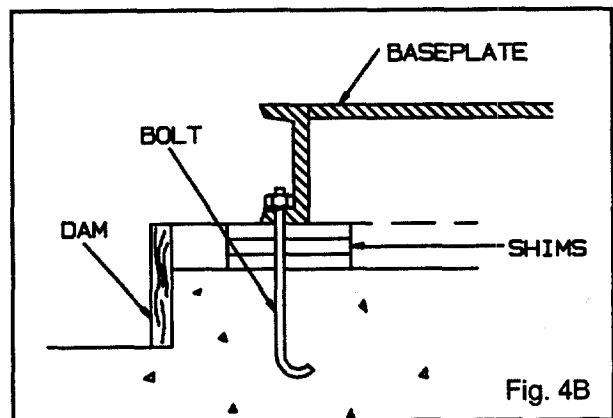
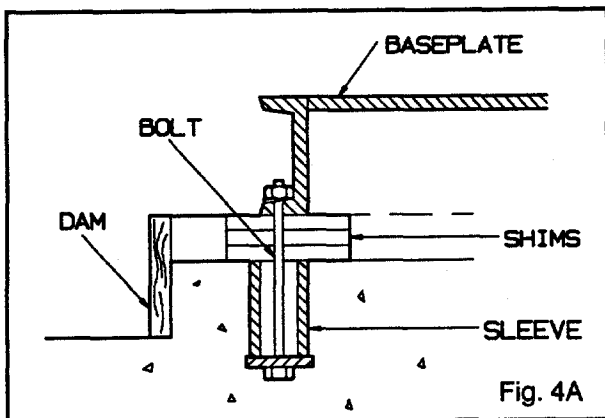

LEVEL BASEPLATE

1. Place 2 sets of wedges or shims on the foundation, one set on each side of every foundation bolt. The wedges should extend .75 in. (20mm) to 1.5 in. (40mm) above foundation, to allow for adequate grouting. This will provide even support for the baseplate once it is grouted.
2. Remove water and/or debris from anchor bolt holes/sleeves prior to grouting. If the sleeve type bolts are being used, fill the sleeves with rags to prevent grout from entering.
3. Carefully lower baseplate onto foundation bolts.
4. Level baseplate to within $\frac{1}{8}$ " (3.2mm) over length of the baseplate and to within .088 in. (1.5mm) over the width of the base by adjusting wedges.
5. Hand tighten bolts.

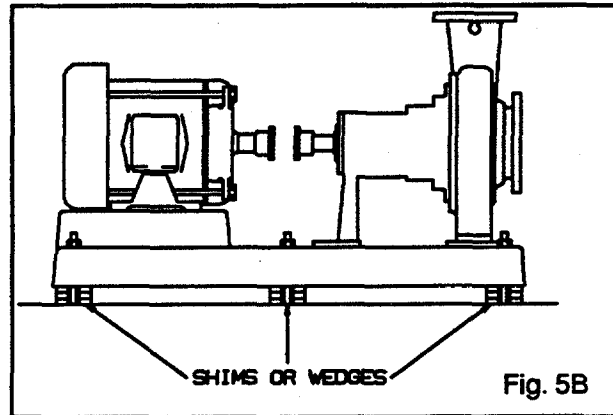
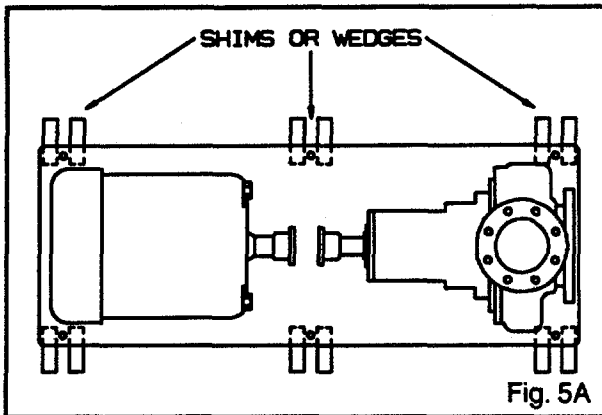

ALIGNMENT AND ALIGNMENT PROCEDURE

WARNING

Before beginning any alignment procedure make sure driver power is locked out. Failure to lock out driver power will result in serious physical injury.

To remove guard refer to coupling guard assembly/disassembly instructions.

The points at which alignment is checked and adjusted are:

- **Initial Alignment** is done prior to operation when the pump and the driver are at ambient temperature.
- **Final Alignment** is done after operation when the pump and driver are at operating temperature.

Alignment is achieved by adding or removing shims from under the feet of the driver and shifting equipment horizontally as needed.

NOTE: Proper alignment is the responsibility of the installer and user of the unit.

Accurate alignment of the equipment must be attained. Trouble free operation can be accomplished by following these procedures.

ALIGNMENT CHECKS

Initial Alignment (Cold Alignment)

- Before Grouting Baseplate - To ensure alignment can be obtained.
- After Grouting Baseplate - To ensure no changes have occurred during grouting process.
- After Connecting Piping - To ensure pipe strains haven't altered alignment. If changes have occurred, alter piping to remove pipe strains on pump flanges.

Final Alignment (Hot Alignment)

- After First Run - To obtain correct alignment when both pump and driver are at operating temperature. Thereafter, alignment should be checked periodically in accordance with plant operating procedures.

NOTE: Alignment check must be made if process temperature changes, piping changes and or pump service is performed.

ALIGNMENT CRITERIA

Good alignment is achieved when the dial indicator readings as specified in the alignment procedure are .002 in. (.05 mm) Total Indicated Reading (T.I.R.) or less when the pump and driver are at operating temperature (Final Alignment).

During the installation phase, however, it is necessary to set the parallel alignment in the vertical direction to a different criteria due to differences in expansion rates of the pump and driver. Table 1 shows recommended preliminary (cold) settings for electric motor driven pumps based on different pumpage temperatures. Driver manufacturers should be consulted for recommended cold settings for other types of drivers (steam turbines, engines, etc.)

| PUMPAGE TEMPERATURE | SET DRIVER SHAFT |
|---------------------|----------------------|
| 50°F (10°C) | .002in. (.05mm) LOW |
| 150°F (65°C) | .001in. (.03mm) HIGH |
| 250°F (120°C) | .005in. (.12mm) HIGH |
| 350°F (175°C) | .009in. (.23mm) HIGH |
| 450°F (218°C) | .013in. (.33mm) HIGH |
| 550°F (228°C) | .017in. (.43mm) HIGH |
| 650°F (343°C) | .021in. (.53mm) HIGH |
| 700°F (371°C) | .023in. (.58mm) HIGH |

NOTE: Above 500°F recommend centerline mounted casing.

SET UP

1. Mount two dial indicators on one of the coupling halves (X) so they contact the other coupling half (Y) (Fig. 6).
2. Check setting of indicators by rotating coupling half X to ensure indicators stay in contact with coupling half Y but do not bottom out. Adjust indicators accordingly.

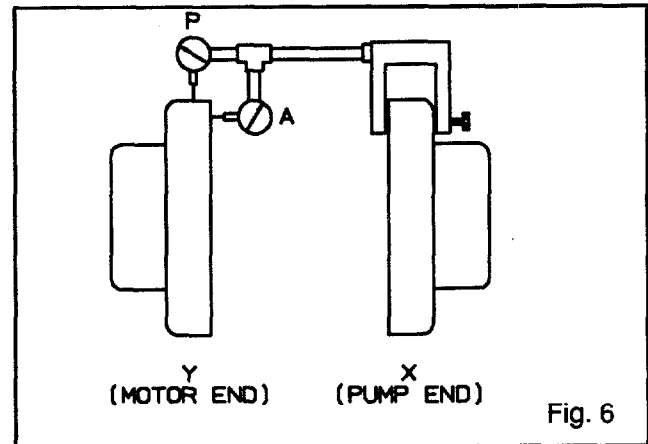

3

MEASUREMENT

1. To ensure accuracy of indicator readings, always rotate both coupling halves together so indicators contact the same point on coupling half Y. This will eliminate any measurement problems due to runout on coupling half Y.
2. Take indicator measurements with driver feet hold-down bolts tightened. Loosen hold down bolts prior to making alignment corrections.
3. Take care not to damage indicators when moving driver during alignment corrections.

ANGULAR ALIGNMENT

A unit is in angular alignment when indicator A (Angular indicator) does not vary by more than .002 in. (.05 mm) as measured at four points 90° apart.

Vertical Correction (Top-to-Bottom)

1. Zero indicator A at top dead center (12 o'clock) of coupling half Y.
2. Rotate indicators to bottom dead center (6 o'clock). Observe needle and record reading.
3. **Negative Reading** - The coupling halves are further apart at the bottom than at the top. Correct by either raising the driver feet at the shaft end (add shims) or lowering the driver feet at the other end (remove shims), (Fig. 7A).

Positive Reading - The coupling halves are closer at the bottom than at the top. Correct by either lowering the driver feet at the shaft end (remove shims) or raising the driver feet at the other end (add shims).

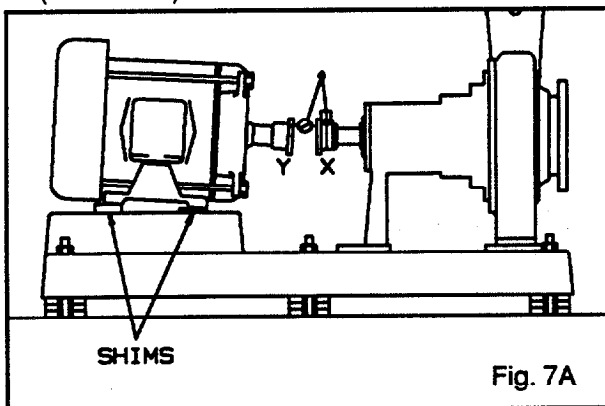

4. Repeat steps 1-3 until indicator A reads .002 in (.05 mm) or less.

Horizontal Correction (Side-to-Side)

1. Zero indicator A on left side of coupling half Y, 90° from top dead center (9 o'clock).
2. Rotate indicators through top dead center to the right side, 180° from the start (3 o'clock). Observe needle and record reading.
3. **Negative Reading** - The coupling halves are further apart on the right side than the left. Correct by either sliding the shaft end of the driver to the left or the other end to the right.

Positive Reading - The coupling halves are closer together on the right side than the left. Correct by either sliding the shaft end of the driver to the right or the other end to the left (Fig. 7B).

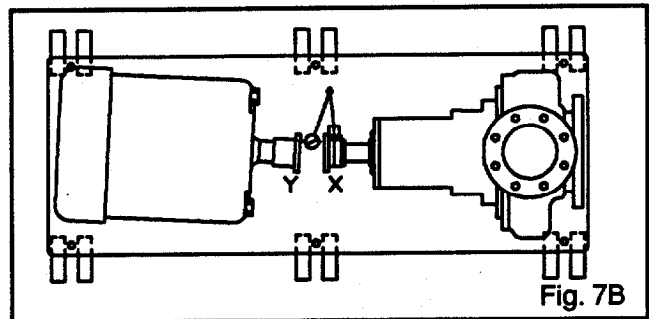

4. Repeat steps 1 through 3 until indicator A reads .002 in. (.05 mm) or less.
5. Re-check both horizontal and vertical readings to ensure adjustment of one did not disturb the other. Correct as necessary.

PARALLEL ALIGNMENT

A unit is in parallel alignment when indicator P (parallel indicator) does not vary by more than .002 in. (.05 mm) as measured at four points 90° apart at operating temperature. Note the preliminary vertical cold setting criteria, Table 1.

Vertical Correction (Top-to-Bottom)

1. Zero indicator P at top dead center of coupling (12 o'clock) half Y (Fig. 6).
2. Rotate indicator to bottom dead center (6 o'clock). Observe needle and record reading.
3. **Negative Reading** - Coupling half X is lower than coupling half Y. Correct by removing shims of thickness equal to half of the indicator reading under each driver foot.

Positive Reading - Coupling half X is higher than coupling half Y. Correct by adding shims of thickness equal to half of the indicator reading from each driver foot (Fig. 8A).

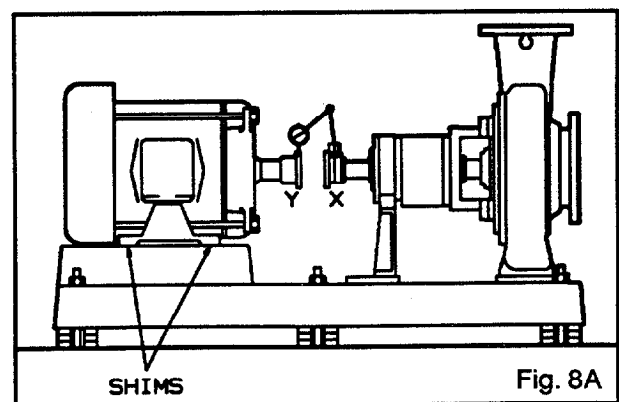

NOTE: Equal amounts of shims must be added to or removed from each driver foot. Otherwise the vertical angular alignment will be affected.

- Repeat steps 1 through 3 until indicator P reads within .002 in. (.05 mm) or less when hot, or per Table 1 when cold.

Horizontal Correction (Side-to-Side)

- Zero indicator P on the left side of coupling half Y, 90° from top dead center (9 o'clock).
- Rotate indicators through top dead center to the right side, 180° from the start (3 o'clock). Observe needle and record reading.
- Negative Reading** - Coupling half Y is to the left of coupling half X. Correct by sliding driver evenly in the appropriate direction (Fig. 8B).

Positive Reading - Coupling half Y is to the right of coupling half X. Correct by sliding driver evenly in the appropriate direction.

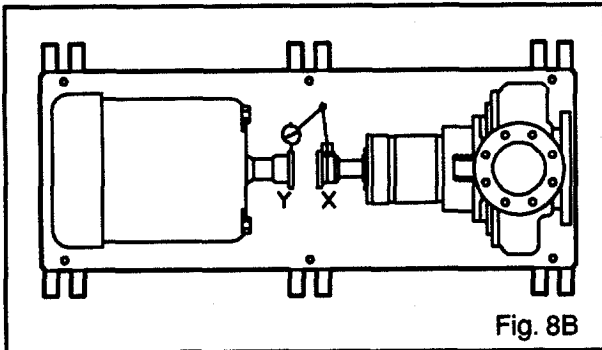

Fig. 8B

NOTE: Failure to slide motor evenly will affect horizontal angular correction

- Repeat steps 1 through 3 until indicator P reads .002 in. (.05 mm) or less.
- Re-check both horizontal and vertical readings to ensure adjustment of one did not disturb the other. Correct as necessary.

COMPLETE ALIGNMENT

A unit is in complete alignment when both indicators A (angular) and P (parallel) do not vary by more than .002 in. (.05 mm) as measured at four points 90° apart.

Vertical Correction (Top-to-Bottom)

- Zero indicators A and P at top dead center (12 o'clock) of coupling half Y.
- Rotate indicator to bottom dead center (6 o'clock). Observe the needles and record the readings.
- Make corrections as outlined previously.

Horizontal Correction (Side-to-Side)

- Zero indicators A and P on the left side of coupling half Y, 90° from top dead center (9 o'clock).
- Rotate indicators through top dead center to the right side, 180° from the start (3 o'clock). Observe the needle, measure and record the reading.
- Make corrections as outlined previously.
- Recheck both vertical and horizontal readings to ensure adjustment of one did not disturb the other. Correct as necessary.

NOTE: With experience, the installer will understand the interaction between angular and parallel and will make corrections appropriately.

3

**Table 2
Alignment Trouble Shooting**

| PROBLEM | PROBABLE CAUSE | REMEDY |
|--|---|---|
| Cannot obtain horizontal (Side-to-Side) alignment, angular or parallel | Driver feet bolt bound. | Loosen pump hold down bolts and slide pump and driver until horizontal alignment is achieved. |
| | Baseplate not leveled properly, probably twisted. | Determine which corner(s) of the baseplate are high or low and remove or add shims at the appropriate corner(s) and realign. |
| Cannot obtain vertical (Top-to-Bottom) alignment, angular or parallel | Baseplate not leveled properly, probably bowed. | Determine if center of baseplate should be raised or lowered and correct by evenly adding or removing shims at the center of the baseplate. |

GROUT BASEPLATE

1. Clean areas of baseplate that will contact grout. Do not use oil-based cleaners because grout will not bond to it. Refer to grout manufacturer's instructions.
2. Build dam around foundation. Thoroughly wet foundation (Fig. 9A).
3. Pour grout through grout hole in baseplate, up to level of dam. Remove air bubbles from grout as it is poured by puddling, using a vibrator, or pumping the grout into place. Non-shrink grout is recommended.
4. Allow grout to set.
5. Fill remainder of baseplate with grout. Remove air as before (Fig. 9B).

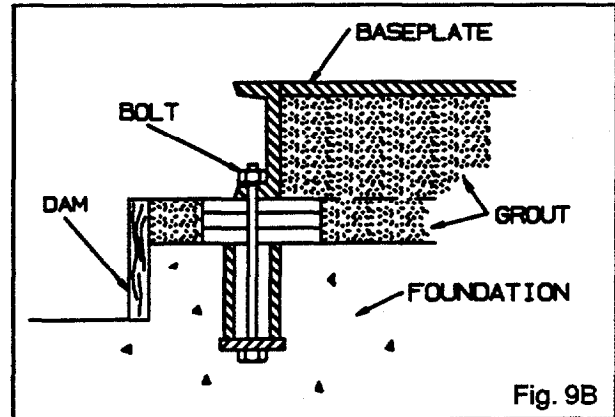
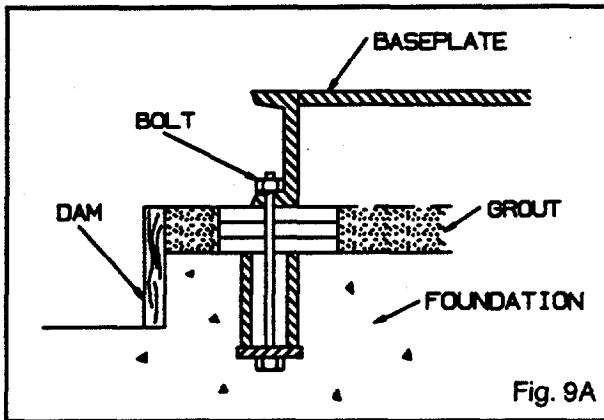

6. Allow grout to set at least 48 hours.
7. Tighten foundation bolts.

ALIGNMENT CHECK

Re-check alignment before continuing, using methods previously described.

PIPING

GENERAL

Guidelines for piping are given in the "Hydraulic Institute Standards" available from: Hydraulic Institute, 30200 Detroit Road, Cleveland, OH 44145-1967 and must be reviewed prior to pump installation.

WARNING

Never draw piping into place by forcing at the flanged connections of the pump. This may impose dangerous strains on the unit and cause misalignment between pump and driver. Pipe strain will adversely affect the operation of the pump resulting in physical injury and damage to the equipment.

1. All piping must be supported independently of, and line up naturally with, the pump flanges.

2. Piping runs should be as short as possible to minimize friction losses.
3. DO NOT connect piping to pump until grout has hardened and pump and driver hold-down bolts have been tightened.
4. It is suggested that expansion loops or joints be properly installed in suction and/or discharge lines when handling liquids at elevated temperatures, so linear expansion of piping will not draw pump out of alignment.
5. The piping should be arranged to allow pump flushing prior to removal of the unit on services handling corrosive liquids.
6. Carefully clean all pipe parts, valves and fittings, and pump branches prior to assembly.

SUCTION PIPING

WARNING

NPSH_A must always exceed NPSH_R as shown on Goulds performance curves received with order. (Reference Hydraulic Institute for NPSH and pipe friction values needed to evaluate suction piping.)

Properly installed suction piping is a necessity for trouble-free pump operation. Suction piping should be flushed BEFORE connection to the pump.

1. Use of elbows close to the pump suction flange should be avoided. There should be a minimum of 2 pipe diameters of straight pipe between the elbow and suction inlet. Where used, elbows should be long radius.
2. Use suction pipe one or two sizes larger than the pump suction, with a reducer at the suction flange. Suction piping should never be of smaller diameter than the pump suction.
3. Reducers, if used, should be eccentric, at the pump suction flange, with sloping side down.
4. Pump must never be throttled on suction side.
5. Suction strainers, when used, must have a net "free area" of at least three times the suction pipe area.
6. Separate suction lines are recommended when more than one pump is operating from the same source of supply.

Suction lift conditions

1. Suction pipe must be free from air pockets.
2. Suction piping must slope upwards to pump.
3. All joints must be air tight.
4. A means of priming the pump must be provided, such as a foot valve.

Suction head/Flooded suction conditions

1. An isolation valve should be installed in the suction line at least two pipe diameters from the suction to permit closing of the line for pump inspection and maintenance.
2. Keep suction pipe free from air pockets.
3. Piping should be level or slope gradually downward from the source of supply.
4. No portion of the piping should extend below pump suction flange.

5. The size of entrance from supply should be one or two sizes larger than the suction pipe.
6. The suction pipe must be adequately submerged below the liquid surface to prevent vortices and air entrainment at the supply.

DISCHARGE PIPING

1. Isolation and check valves should be installed in discharge line. Locate the check valve between isolation valve and pump, this will permit inspection of the check valve. The isolation valve is required for priming, regulation of flow, and for inspection and maintenance of pump. The check valve prevents pump or seal damage due to reverse flow through the pump when the driver is turned off.
2. Increasesers, if used, should be placed between pump and check valves.
3. Cushioning devices should be used to protect the pump from surges and water hammer if quick-closing valves are installed in system.

3

FINAL PIPING CHECK

After connecting the piping to pump:

1. Rotate shaft several times by hand to be sure that there is no binding and all parts are free.
2. Check alignment, per the alignment procedure outlined previously to determine absence of pipe strain. If pipe strain exists, correct piping.

OPERATION

| | |
|---|-----------|
| PREPARATION FOR START-UP | 21 |
| Checking Rotation | 21 |
| Check Impeller Clearance | 21 |
| Couple Pump and Driver | 22 |
| Lubricating Bearings | 22 |
| Shaft Sealing | 22 |
| Priming Pump | 24 |
| STARTING PUMP | 25 |
| OPERATION | 26 |
| General Considerations | 26 |
| Operating at Reduced Capacity | 26 |
| Operating under Freezing Conditions | 26 |
| SHUTDOWN | 26 |
| FINAL ALIGNMENT | 26 |

PREPARATION FOR START-UP

CHECKING ROTATION

CAUTION
Serious damage may result if pump is run in the wrong rotation.

1. Lock out power to driver.

WARNING
Lock out driver power to prevent accidental start-up and physical injury.

2. Make sure coupling hubs are securely fastened to shafts.

NOTE: *Pump is shipped with coupling spacer removed.*

3. Unlock driver power.
4. Make sure everyone is clear. Jog driver just long enough to determine direction of rotation. Rotation must correspond to arrow on bearing housing.
5. Lock out power to driver.

CHECK IMPELLER CLEARANCE

The pump efficiency is maintained when the proper impeller clearance is set. The clearance is set at .015 in. (.38 mm) at the factory but could change due to piping attachment. Also, for pumpage temperatures over 200°F (93°C) the cold setting must be increased per Table 3. This is necessary to prevent the impeller from contacting the casing due to shaft expansion from the higher operating temperatures. See *Preventive Maintenance* section for impeller adjustment procedure.

| COLD TEMPERATURE CLEARANCES FOR VARIOUS SERVICE TEMPERATURES | |
|--|-----------------|
| 200°F (93°C) | .015in. (.38mm) |
| 250°F (121°C) | .017in. (.43mm) |
| 300°F (149°C) | .019in. (.48mm) |
| 350°F (177°C) | .021in. (.53mm) |
| 400°F (204°C) | .023in. (.58mm) |
| Over 400°F (204°C) | .025in. (.64mm) |

COUPLE PUMP AND DRIVER

WARNING

Lock out driver power to prevent accidental rotation and physical injury.

1. Install and lubricate coupling per manufacturer's instructions.
2. Install coupling guard. (Fig. 12). Refer to Coupling Guard Installation and Disassembly Section (Appendix II).

WARNING

Never operate a pump without coupling guard properly installed. Refer to Appendix II for coupling guard installation instructions. Personal injury will occur if pump is run without coupling guard.

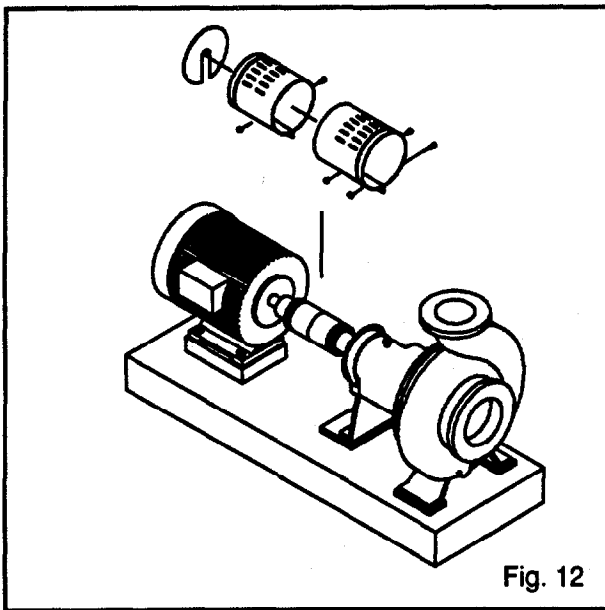

Fig. 12

LUBRICATING BEARINGS

CAUTION

Pumps are shipped without oil.

Oil Lubrication: Fill bearing frame with oil, through filler connection (located on top of bearing frame refer to Fig. 18B), until oil level reaches the middle of the sight-glass. A high quality turbine type oil, with rust and oxidation inhibitors should be used.

Pure Oil Mist Lubrication: Oil mist is an optional feature for the LF 3196. Follow oil mist generator manufacturer's instructions. The inlet connections are located on the top of the bearing frame, connection

points are covered under lubrication. (Refer to Appendix I on converting lubrication).

Grease Lubrication: Pumps are shipped with grease. See Table 6.

Greased For Life Bearings: These bearings are filled with grease and sealed by the bearing manufacturer.

If pump is put into operation after prolonged shut-down, flush out bearings and bearing frame with a light oil to remove contaminants. During flushing rotate shaft slowly by hand. Finally, flush bearing housing with proper lubricating oil to insure oil quality after cleaning.

See Preventive Maintenance section for lubrication recommendations.

WARNING

Operation of the unit without proper lubrication will cause bearing failure, and pump seizure.

SHAFT SEALING

Mechanical Seal Option: Pumps may be shipped with or without mechanical seals installed. A common seal with this model is the cartridge type. Cartridge seals are preset at the seal manufacturer's facility and require no field settings. Cartridge Seals installed by the user require removal of the holding clips prior to operation, allowing the seal to slide into place. If the seal has been installed in the pump at the Goulds factory, these clips have already been removed. For other types of mechanical seals, refer to the seal manufacturer's instructions for installation and setting.

Connection of Sealing Liquid: For satisfactory operation, there must be a liquid film between seal faces to lubricate them. Refer to seal manufacturer's drawing for location of taps. Some methods which may be used to flush/cool the seal are:

- a. **Product Flushing** - In this arrangement, the pumpage is piped from the casing (and cooled in an external heat exchanger when required) then injected into seal gland.
- b. **External Flush** - A clean, cool compatible liquid is injected from an outside source directly into seal gland. Flushing liquid must be at a pressure 15-20 psi (1.1-1.4 kg/cm²) greater than the stuffing box/seal chamber pressure. Injection rate should be ¼-½ GPM (1-2 LPM).

- c. Other methods may be used which make use of multiple gland connections and/or seal chamber connections. Refer to documentation supplied with the pump, mechanical seal reference drawing, and piping diagrams.

Packed Stuffing Box Option: Pumps are shipped without packing, lantern ring or split gland installed. These are included with the box of fittings shipped with the pump and must be installed before start-up.

Installation of packing:

1. Carefully clean stuffing box bore.
2. Twist the packing just enough to get it around the shaft (Fig. 13A,B).
3. Insert packing, staggering the joints in each ring by 90°.
4. The stuffing box arrangement in order of installation is: 2 packing rings, lantern ring (one piece), then 3 packing rings.

CAUTION
 Follow instructions to insure the lantern ring is located at the flushing connection. Fig. 14 otherwise no flush will be obtained.

5. Install the gland halves and evenly hand tighten the nuts.

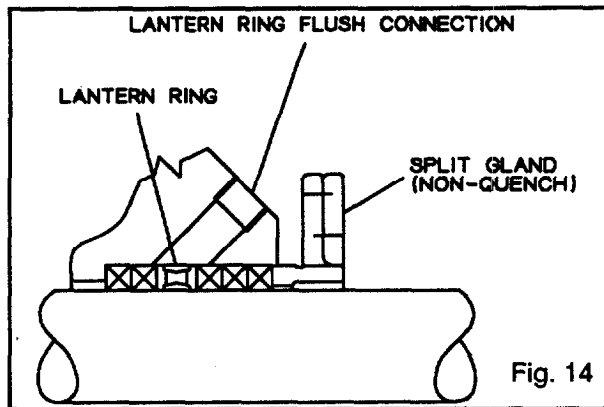
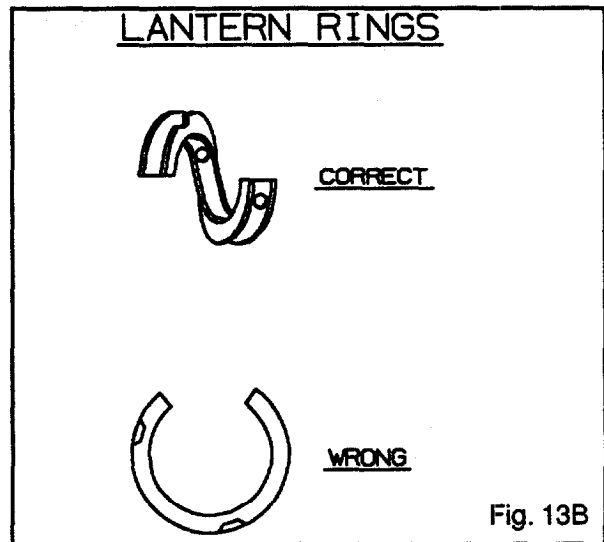
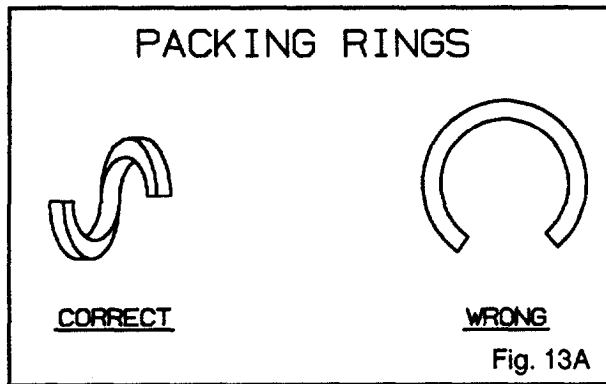

4

Connection of Sealing Liquid: If stuffing box pressure is above atmospheric pressure and pumpage is clean, normal gland leakage of 40-60 drops per minute is usually sufficient to lubricate and cool packing and sealing liquid is not required.

NOTE: Otherwise an external flush should be used to lubricate and cool packing.

An external sealing liquid is required when:

1. Abrasive particles in pumpage could score shaft sleeve.
2. Stuffing box pressure is below atmospheric pressure due to pump running with suction lift, or when suction source is under vacuum. Under these conditions, packing will not be cooled and lubricated and air will be drawn into pump.

If an outside source of clean compatible liquid is required, the pressure should be 15-20 psi (1.1-1.4 kg/cm²) above suction pressure. The piping should be connected to the lantern ring connection.

NOTE: Most packing requires lubrication. Failure to lubricate packing may shorten the life of the packing and pump.

Dynamic Seal Option: The dynamic seal consists of two seals: a repeller that prevents leakage during pump operation and a secondary seal that prevents leakage when the unit is off. The repeller acts as a pump to prevent liquid from entering the stuffing box during pump operation. The repeller does not require a flush except for services which allow a build-up of solids on the repeller. A flush hole can be provided for this purpose. A drain hole can also be supplied to drain repeller chamber if danger of freezing exists.

Secondary Seals: The secondary seal prevents leakage during pump shut down. This seal is either graphite packing or an elastomeric face or lip seal.

1. **Graphite packing** - This packing will provide adequate life running dry but will provide longer performance if it is lubricated with either clean water or grease. When clean water is used, remember that the repeller reduces both the quantity and pressure of seal water required. If the suction head is less than the repeller capability, the stuffing box pressure is the same as atmospheric. Seal water pressure must be high enough to overcome static head when the pump is not operating to keep pumpage out of the packing. Flow must be sufficient to cool the packing. If grease is used as the lubricant, spring-loaded grease lubricators should be used to maintain a constant supply.
2. **Elastomeric Face or Lip seal** - The elastomeric face seal consists of an elastomer rotary fitted to the shaft, and a ceramic stationary seat fitted in the gland. To set the seal, remove the gland nuts and slide the gland back on the sleeve. Pull the rotary back on the sleeve until it is about 1 inch beyond the stuffing box face. Push the gland back onto the studs, pushing the rotary back along the sleeve. Tighten the gland nuts. This ensures contact, no other adjustments are needed. The lip seal is pressed into the gland and no adjustment is required. Both seals are designed to run dry, so no flush is required.

PRIMING PUMP

Never start the pump until it has been properly primed. Several different methods of priming can be used, depending upon type of installation and service involved.

Suction Supply Above Pump:

1. Slowly open the suction valve (Fig. 15).
2. Open air vents on the suction and discharge piping until water flows out.
3. Close the vent valves.

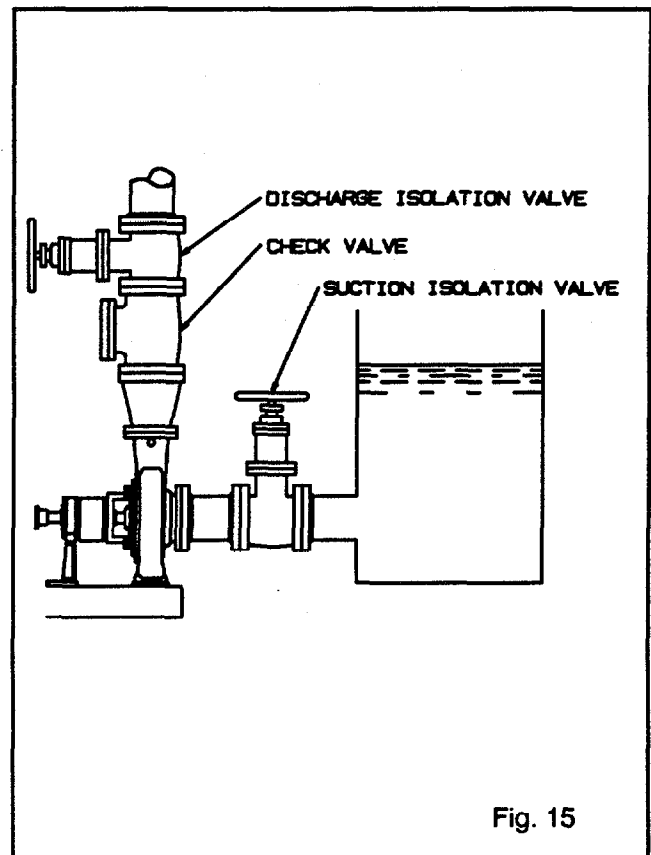

Suction supply below pump: A foot valve and outside source of liquid may be used to prime the pump. Outside source of liquid can come from a priming pump, pressurized discharge line, or other outside supply (Fig. 16 and 17).

1. Close discharge valve and open air vents in casing.
2. Open valve in outside supply line until only water escapes from vent valves.
3. Close the vent valves and then the outside supply line.

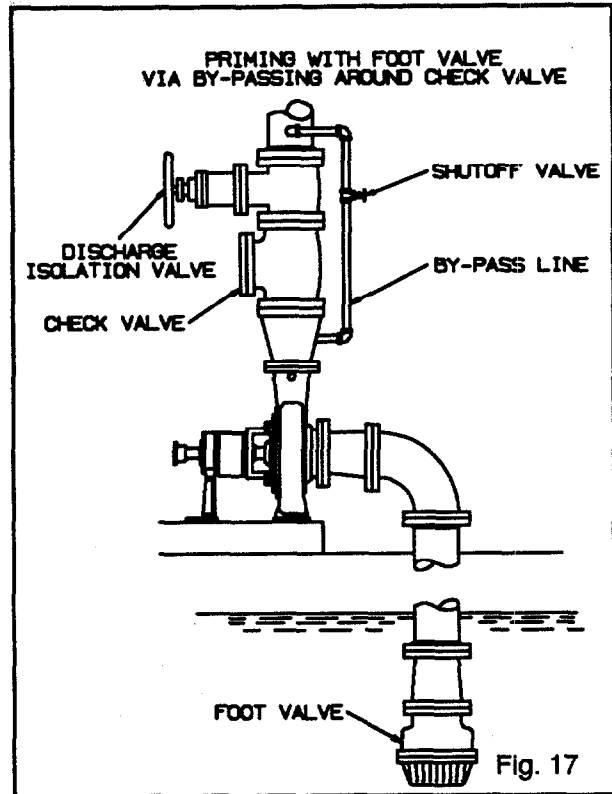
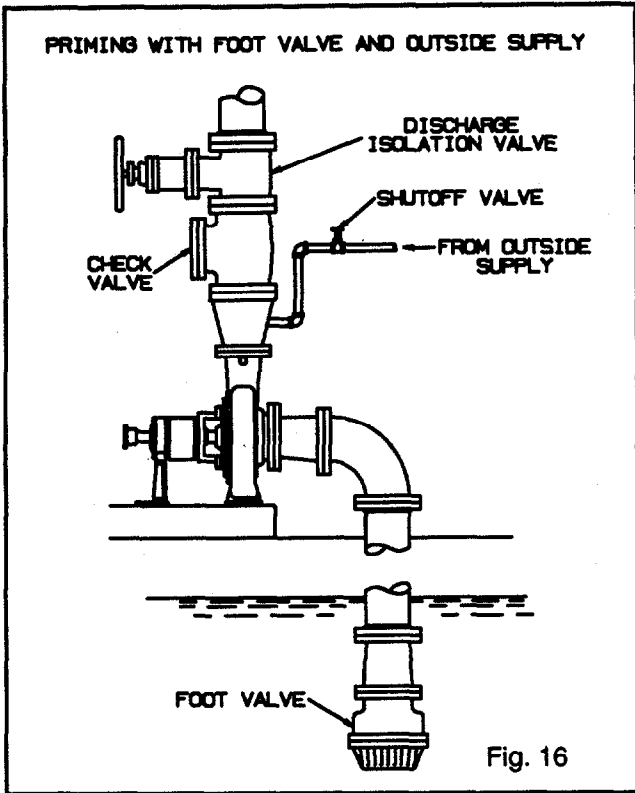

4

Other Methods of Priming:

1. Priming by Ejector.
2. Priming by Automatic Priming Pump.

STARTING PUMP

1. Make sure suction valve and any recirculation or cooling lines are open.
2. Fully close or partially open discharge valve as dictated by system conditions.
3. Start Driver.

4. Slowly open discharge valve until the desired flow is obtained.

CAUTION

Immediately observe pressure gauges. If discharge pressure is not quickly attained - stop driver, reprime and attempt to restart.

CAUTION

Observe pump for vibration levels, bearing temperature and excessive noise. If normal levels are exceeded, shut down and resolve.

OPERATION

GENERAL CONSIDERATIONS

Always vary capacity with regulating valve in the discharge line. **NEVER** throttle flow from the suction side.

Driver may overload if the pumpage specific gravity (density) is greater than originally assumed, or the rated flow rate is exceeded.

Always operate the pump at or near the rated conditions to prevent damage resulting from cavitation or recirculation.

Damage occurs from:

1. Increased vibration levels - Affects bearings, stuffing box or seal chamber, and mechanical seal.
2. Increased radial thrusts - Stresses on shaft and bearings.
3. Heat build up - Vaporization causing rotating parts to score or seize.
4. Cavitation - Damage to internal surfaces of pump.

OPERATING AT REDUCED CAPACITY

WARNING

DO NOT operate pump below minimum rated flows or with discharge valve closed. These conditions may create an explosive hazard due to vaporization of pumpage and can quickly lead to pump failure and physical injury.

OPERATING UNDER FREEZING CONDITIONS

Exposure to freezing conditions, while pump is idle, could cause liquid to freeze and damage the pump. Liquid inside pump should be drained. Liquid inside cooling coils, if supplied, should also be drained.

SHUTDOWN

1. Slowly close discharge valve.
2. Shut down and lock driver to prevent accidental rotation.

WARNING

When handling hazardous and/or toxic fluids, skin and eye protection are required. If pump is being drained, precautions must be taken to prevent physical injury. Pumpage must be handled and disposed of in conformance with applicable environmental regulation.

FINAL ALIGNMENT

1. Run the unit under actual operating conditions for a sufficient length of time to bring the pump and driver up to operating temperature.
2. Check alignment while unit is still hot per alignment procedure in Section 3.
3. Reinstall coupling guard. Refer to coupling guard instruction in Appendix II.

PREVENTIVE MAINTENANCE

| | |
|---|-----------|
| GENERAL COMMENTS | 27 |
| MAINTENANCE SCHEDULE | 27 |
| MAINTENANCE OF BEARINGS | 28 |
| Oil lubricated bearings | 28 |
| Grease lubricated bearings | 29 |
| MAINTENANCE OF SHAFT SEALS | 30 |
| Packed Stuffing Box | 30 |
| Mechanical Seals | 30 |
| Dynamic Seal | 30 |
| IMPELLER CLEARANCE SETTING | 31 |
| Dial Indicator Method | 31 |
| Feeler Gauge Method | 32 |
| TROUBLE SHOOTING | 33 |

GENERAL COMMENTS

5

A routine maintenance program can extend the life of your pump. Well maintained equipment will last longer and require fewer repairs. You should keep maintenance records, this will help pinpoint potential causes of problems.

MAINTENANCE SCHEDULE

Routine Maintenance

- Bearing lubrication
- Seal Monitoring
- Vibration analysis
- Discharge pressure
- Temperature monitoring

Routine Inspections

- Check level and condition of oil through sight glass on bearing frame.

- Check for unusual noise, vibration and bearing temperatures.
- Inspect pump and piping for leaks.
- Check seal chamber/stuffing box leakage.
 - Mechanical Seal: Should be no leakage.
 - Packing: Excessive leakage requires adjustment or possible packing replacement. Refer to Section 4: Operation for packing gland adjustment.

3 Month Inspections

- Check foundation and hold-down bolts for tightness.
- If pump has been left idle, check packing. Replace if required.
- Oil should be changed at least every 3 months (2000 hours) or more often if there are any adverse atmospheric conditions or other conditions which might contaminate or break down the oil, or if it is cloudy or contaminated as seen by inspection through the sight glass.
- Check shaft alignment and realign if required.

Annual Inspections

- Check pump capacity, pressure and power. If pump performance does not satisfy your process requirements, and process requirements have not changed, pump should be disassembled, inspected, and worn parts should be replaced, otherwise, a system inspection should be done.

MAINTENANCE OF BEARINGS

OIL LUBRICATED BEARINGS

WARNING

Pumps are shipped without oil. Oil lubricated bearings must be lubricated at the job site.

Remove fill plug (408H) and add oil until level is at the center of the sight glass (319). Replace fill plug (Fig. 18A). See Table 4.

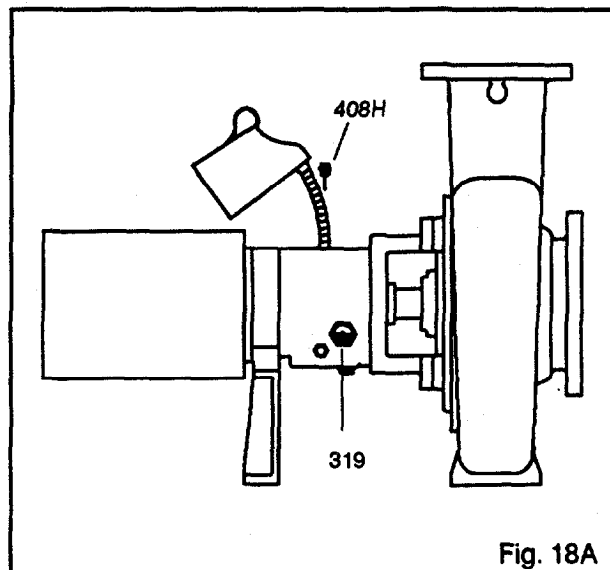

Fig. 18A

Change the oil after 200 hours for new bearings, thereafter every 2000 operating hours or 3 months (whichever comes first).

**Table 4
Oil Volumes**

| Frame | Pints | ml |
|-------|-------|------|
| STX | 1.0 | 400 |
| MTX | 2.6 | 1250 |
| LTX | 3.0 | 1400 |

A high quality turbine oil with rust and oxidation inhibitors should be used. For the majority of operational conditions, bearing temperatures will run between 120°F (50°C) and 180°F (82°C). In this range, an oil of ISO viscosity grade 68 at 100°F (40°C) is recommended. If bearing temperatures exceed 180°F (82°C) use ISO viscosity grade 100 with Bearing Frame cooling. See Table 5. For higher operating temperatures, pumpage above 350°F (177°C), synthetic lubrication is recommended.

**Table 5
Lubricating Oil Requirements**

| | Pumpage temperature below 350°F (177°C) | Pumpage temperature above 350°F (177°C) |
|---|--|--|
| ISO Grade | VG 68 | VG 100 |
| Approx. SSU at 100°F (38°C) | 300 | 470 |
| DIN 51517 | C68 | C100 |
| Kinem. viscosity at 100°F (40°C) mm ² /sec | 68 | 100 |

Some acceptable lubricants are:

- Exxon Teresstic EP 68
- Mobil Mobil DTE 26 300 SSU
 @ 100°F (38°C)
- Sunoco Sunvis 968
- Royal Purple SYNFILM ISO VG 68
 Synthetic Lube

GREASE LUBRICATED BEARINGS

Grease lubricated bearings are pre-lubricated at the factory. Regrease bearings every 2000 operating hours or 3 months.

Regrease Procedure:

NOTE: When regreasing there is danger of impurities entering the bearing housing. The grease container, the greasing device, and fittings, must be clean.

1. Wipe dirt from grease fittings.
2. Remove 2 grease relief plugs (408H) from bottom of frame.
3. Fill both grease cavities through fittings with recommended grease until fresh grease comes out of the relief holes. Reinstall grease relief plugs (408H).
4. Ensure frame seals are seated in bearing housing and if not press in place with drains located at the bottom .

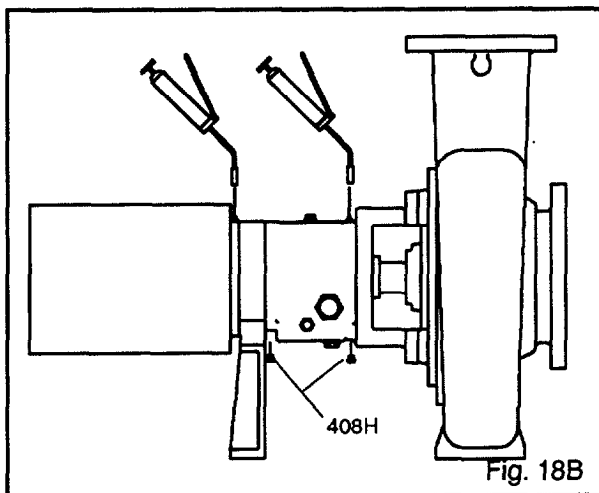

NOTE: The bearing temperature usually rises after regreasing due to an excess supply of grease. Temperatures will return to normal after pump has run and purged the excess from the bearings, usually two to four hours.

For most operating conditions a lithium based mineral oil grease of NLGI consistency No. 2 is recommended. This grease is acceptable for bearing temperatures of 5°F to 230°F (-15°C to 110°C). Bearing temperatures are generally about 20°F (18°C) higher than bearing housing outer surface temperature.

| | Pumpage temperature below 350°F (177°C) | Pumpage temperature above 350°F (177°C) |
|------------------|---|---|
| NLGI consistency | 2 | 3 |
| Mobil | Mobilux EP2 | |
| Exxon | Unirex N2 | Unirex N3 |
| Sunoco | Multipurpose EP, | |
| SKF | LGMT 2 | LGMT 3 |

5

CAUTION

Never mix greases of different consistency (NLGI 1 or 3 with NLGI 2) or different thickener. For example never mix a lithium base grease with a polyurea base grease.

Pumpage temperatures above 350°F (177°C) should be lubricated by a high temperature grease. Mineral oil greases should have oxidation stabilizers and a consistency of NLGI 3.

NOTE: If it is necessary to change grease type or consistency, the bearings must be removed and the old grease removed.

MAINTENANCE OF SHAFT SEALS

1. Mechanical Seals

When mechanical seals are furnished, a manufacturer's reference drawing is supplied with the data package. This drawing should be kept for future use when performing maintenance and adjusting the seal. The seal drawing will also specify required flush liquid and attachment points. The seal and all flush piping must be checked and installed as needed prior to starting the pump.

The life of a mechanical seal depends on various factors such as cleanliness of the liquid handled and its lubricating properties. Due to the diversity of operating conditions it is, however, not possible to give definite indications as to its life.

WARNING

Never operate the pump without liquid supplied to mechanical seal. Running a mechanical seal dry, even for a few seconds, can cause seal damage and must be avoided. Physical injury can occur if mechanical seal fails.

2. Packed Stuffing Box

WARNING

Lock out driver power to prevent accidental start-up and physical injury.

The stuffing box is not packed at the factory and must be packed properly before operation of the pump. The packing is furnished in a box of fittings which accompany the pump. The packing used must be suitable for the pumpage. Make sure the stuffing box is clean. Examine shaft-sleeve for wear or scoring, replace if necessary.

Starting from the innermost ring, the packing is usually arranged as two packing rings, lantern ring, three packing rings, followed by the split gland (Fig. 14). Insert single packing rings by twisting as shown in Fig. 6. Press each ring to ensure proper compression in the stuffing box. Stagger joints 90°. Refer to Fig. 13A, 13B.

Lightly and evenly tighten the gland. Excessive tightening will result in premature failure of the packing and shaft sleeve. After packing it must be possible to rotate shaft by hand. Final adjustment of packing gland is made after pump is started.

3. Dynamic Seal

Dynamic Seal Components

Repeller - The dynamic repeller effectively prevents leakage of pumpage through the stuffing box when the pump is operating under published acceptable conditions. Dynamic seal parts do not wear substantially to affect operation unless the service is particularly abrasive or corrosive. Refer to Section 6 for maintenance disassembly and repair.

A static seal is used to prevent leakage when the pump is shut down. This is either a lip seal, elastomeric face seal, or graphite packing. The lip and elastomeric face seal require no maintenance other than replacement when leakage becomes excessive. The packing should be installed as for stuffing box packing, and is a special type designed to run dry, so does not require an external flush.

IMPELLER CLEARANCE SETTING

WARNING

Lock out driver power to prevent accidental startup and physical injury.

A change in pump performance may be noted over time by a drop in head or flow or an increase in power required. Performance can usually be renewed by adjusting the impeller clearance. Two techniques are given to set the impeller clearance, the dial indicator method and the feeler gauge method.

DIAL INDICATOR METHOD

1. Remove coupling guard. Refer to coupling guard instructions *Appendix II*.
2. Remove coupling.
3. Set indicator so that button contacts either the shaft end or against face of coupling (Fig. 19).
4. Loosen jam nuts (423B) on jack bolts (371A) and back bolts out about two turns.
5. Tighten each locking bolt (370C) evenly, drawing the bearing housing (134A) towards the bearing frame (228) until impeller contacts the casing. Turn the shaft to ensure contact is made.
6. Set indicator to zero and back locking bolt (370C) out about one turn.
7. Thread jack bolts (371A) in until they evenly contact the bearing frame. Tighten the jack bolts evenly (about one flat at a time) backing the bearing housing (134A) away from the bearing frame until the indicator shows the proper clearance per Table 3.
8. Evenly tighten locking bolts (370C), then jack bolts (371A) keeping indicator reading at proper setting.
9. Check shaft for free turning.
10. Replace coupling guard.

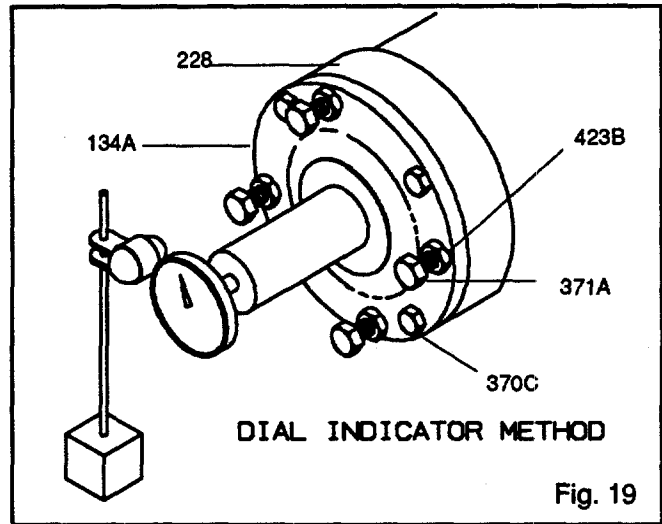

FEELER GAUGE METHOD

1. Remove coupling guard. Refer to coupling guard instructions in *Appendix II*.
2. Loosen jam nuts (423B) on jack bolts (371A) and back bolts out about two turns (Fig. 20).
3. Tighten locking bolts (370C) evenly, drawing bearing housing (134A) towards frame (228) until impeller contacts the casing. Turn shaft to ensure contact is made.
4. With a feeler gauge set the gap between the three locking bolts (370C) and bearing housing (134A) per impeller clearances in Table 3.
5. Evenly back out bearing housing (134A) using the three jack bolts (371A) until it contacts the locking bolts (370C). Evenly tighten jam nuts (423B).
6. Check shaft for free turning.
7. Replace coupling guard.

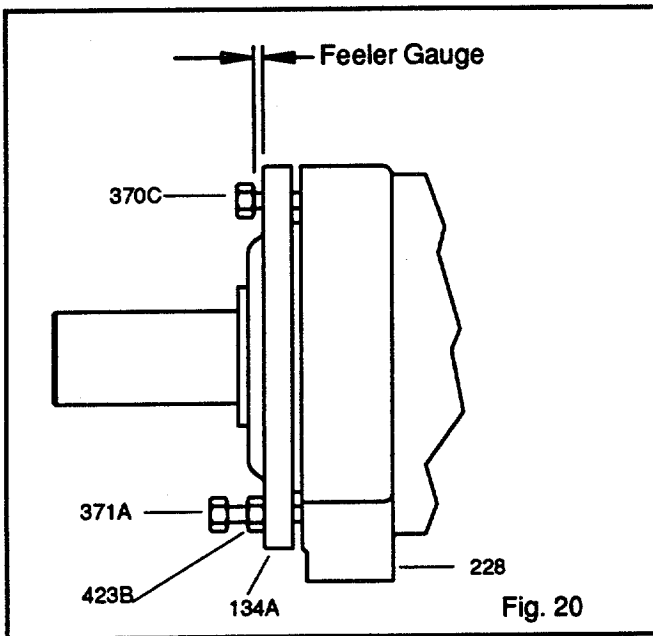

**Table 3
Impeller
Clearances**

| COLD TEMPERATURE CLEARANCES FOR VARIOUS SERVICE TEMPERATURES | |
|---|---------------------|
| 200°F (93°C) | 0.015 in. (0.38 mm) |
| 250°F (121°C) | 0.017 in. (0.43 mm) |
| 300°F (149°C) | 0.019 in. (0.48 mm) |
| 350°F (177°C) | 0.021 in. (0.53 mm) |
| 400°F (204°C) | 0.023 in. (0.58 mm) |
| Over 400°F (204°C) | 0.025 in. (0.64 mm) |

TROUBLE SHOOTING

**Table 7
Troubleshooting Pump**

| PROBLEM | PROBABLE CAUSE | REMEDY |
|---|---|--|
| No liquid delivered. | Pump not primed. | Reprime pump, check that pump and suction line are full of liquid. |
| | Suction line clogged. | Remove obstructions. |
| | Impeller clogged with foreign material. | Back flush pump to clean impeller. |
| | Wrong direction of rotation. | Change rotation to concur with direction indicated by arrow on bearing housing or pump casing. |
| | Foot valve or suction pipe opening not submerged enough. | Consult factory for proper depth. Use baffle to eliminate vortices. |
| | Suction lift too high. | Shorten suction pipe. |
| Pump not producing rated flow or head. | Air leak thru gasket. | Replace gasket. |
| | Air leak thru stuffing box | Replace or readjust packing/mechanical seal. |
| | Impeller partly clogged. | Back flush pump to clean impeller. |
| | Worn suction sideplate or wear rings. | Replace defective part as required. |
| | Insufficient suction head. | Ensure that suction line shutoff valve is fully open and line is unobstructed. |
| | Worn or broken impeller. | Inspect and replace if necessary. |
| Pump starts then stops pumping. | Improperly primed pump. | Reprime pump. |
| | Air or vapor pockets in suction line. | Rearrange piping to eliminate air pockets. |
| | Air leak in suction line. | Repair (plug) leak. |
| Bearings run hot. | Improper alignment. | Re-align pump and driver. |
| | Improper lubrication. | Check lubricant for suitability and level. |
| | Lube cooling. | Check cooling system. |
| Pump is noisy or vibrates. | Improper pump/driver alignment. | Align shafts. |
| | Partly clogged impeller causing imbalance. | Back-flush pump to clean impeller. |
| | Broken or bent impeller or shaft. | Replace as required. |
| | Foundation not rigid. | Tighten hold down bolts of pump and motor or adjust stilts. |
| | Worn bearings. | Replace. |
| | Suction or discharge piping not anchored or properly supported. | Anchor per Hydraulic Institute Standards Manual recommendations |
| | Pump is cavitating. | System problem. |
| Excessive leakage from stuffing box. | Packing gland improperly adjusted. | Tighten gland nuts. |
| | Stuffing box improperly packed. | Check packing and repack box. |
| | Worn mechanical seal parts. | Replace worn parts. |
| | Overheating mechanical seal. | Check lubrication and cooling lines. |
| | Shaft sleeve scored. | Remachine or replace as required. |
| Motor requires excessive power. | Head lower than rating. Pumps too much liquid. | Consult factory. Install throttle valve, trim impeller diameter. |
| | Liquid heavier than expected. | Check specific gravity and viscosity. |
| | Stuffing packing too tight. | Readjust packing. Replace if worn. |
| | Rotating parts bind. | Check internal wearing parts for proper clearances. |

DISASSEMBLY & REASSEMBLY

| | |
|--------------------------|----|
| REQUIRED TOOLS | 35 |
| DISASSEMBLY | 35 |
| INSPECTIONS | 44 |
| REASSEMBLY | 49 |

REQUIRED TOOLS

- 9/16", 3/4", 7/8", 15/16" Open end wrenches
- Lifting sling
- Impeller wrench
STX, MTX - Goulds part # A01676A
LTX - Goulds part # A03749A
- 7/16" open end wrench (LTX)
- Induction bearing heater
- Brass drift punch
- Spanner wrench
- Snap-ring pliers
- Allen wrenches
- Torque wrench with sockets
- Dial indicator
- Micrometer
- Cleaning Agents
- Feeler gauges

6

DISASSEMBLY

WARNING

Pump components can be heavy. Proper methods of lifting must be employed to avoid physical injury and/or equipment damage.

WARNING

The LF 3196 may handle hazardous and/or toxic fluids. Skin and eye protection are required. Precautions must be taken to prevent physical injury. Pumpage must be handled and disposed of in conformance with applicable Environmental Regulations.

NOTE: *Before disassembling the pump for overhaul, ensure all replacement parts are available.*

WARNING

Lock out power supply to driver motor to prevent accidental startup and physical injury.

1. Shut off all valves controlling flow to and from pump.

WARNING

Operator must be aware of pumpage and safety precautions to prevent physical injury.

2. Drain liquid from piping, flush pump if necessary.
3. Disconnect all auxiliary piping and tubing.
4. Remove coupling guard. Refer to Coupling Guard Installation and Disassembly Section in Appendix 2.

5. Disconnect Coupling.
6. Remove coupling guard pump endplate.
7. If oil lubricated, drain oil from bearing frame by removing bearing frame drain plug (408A). Replace plug after oil is drained. Remove oil reservoir, if equipped (Fig. 21).

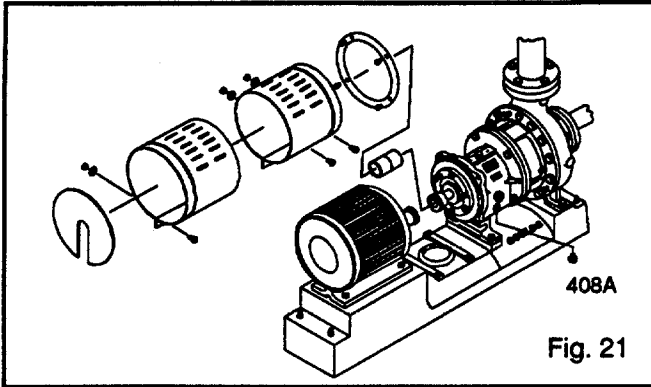

Fig. 21

NOTE: Oil analysis should be part of a preventive maintenance program, and is helpful to determine cause of a failure. Save oil in a clean container for inspection.

8. Place sling from hoist through frame adapter (108) or frame (228A) for STX (Fig. 22).
9. Remove bearing frame foot hold down bolts (370F).
10. Remove casing bolts (370).

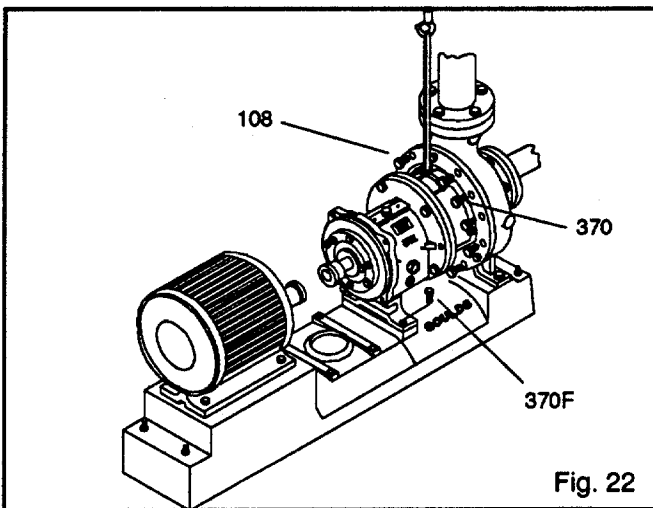

Fig. 22

WARNING

Never apply heat to remove parts. Use of heat may cause an explosion due to trapped fluid, resulting in severe physical injury and property damage.

11. Remove back pull-out assembly from casing (100). Tighten jack screws (418) evenly to remove back pull-out assembly (Fig. 23).

NOTE: Penetrating oil can be used if adapter to casing joint is excessively corroded.

NOTE: Remove and then mark shims from under frame foot.

WARNING

Never remove the back pull-out assembly unassisted, physical injury can occur.

12. Remove casing gasket (351) and discard. Replace with new gasket during reassembly.)
13. Remove jack screws (418).

NOTE: Casing gasket (351) may partially adhere to casing due to binders and adhesives in the gasket material. Clean all gasket surfaces.

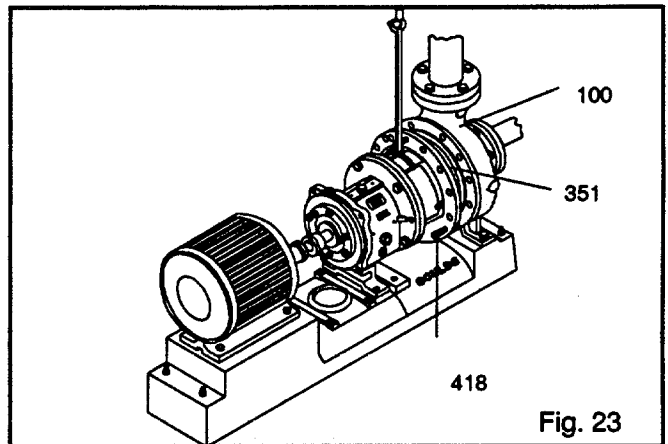

Fig. 23

14. Move back pull-out assembly to clean work bench.
15. Support frame adapter (108) securely to workbench.

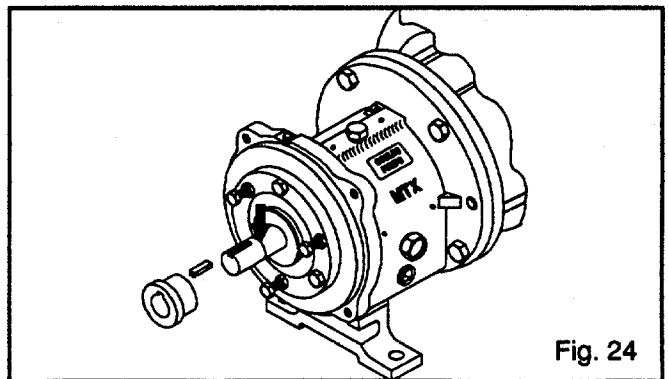

Fig. 24

NOTE: Blue and scribe shaft for relocating coupling hub during reassembly.

16. Remove coupling hub (Fig. 24).

REMOVAL OF IMPELLER

WARNING

Never apply heat to remove impeller. Use of heat may cause an explosion due to trapped fluid, resulting in severe physical injury and property damage.

WARNING

When removing impeller (101) wear heavy work gloves to prevent cutting hands on the sharp edges of impeller vanes.

17. Remove impeller (101) from shaft (122). Slide Goulds shaft wrench (A01676A for STX and MTX, or A03749A for LTX) over shaft (122) and key. Rotate impeller clockwise (viewed from impeller end of shaft) raising wrench off work surface. Quickly turn impeller (101) counterclockwise (viewed from impeller end of shaft) impacting wrench handle on workbench or solid block until impeller (101) loosens (Fig. 25).

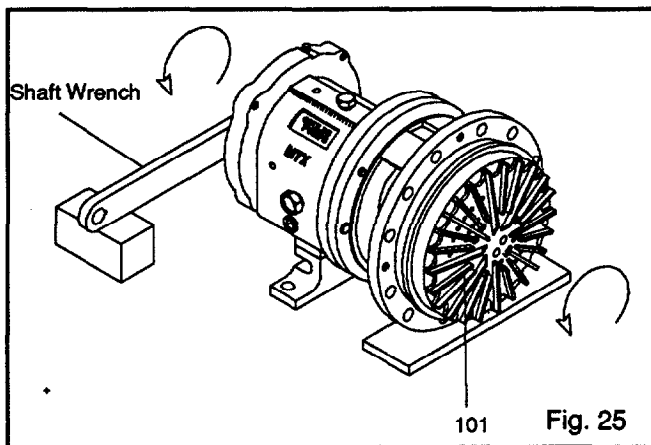

18. Remove impeller O-ring (412A) and discard (Fig. 26).

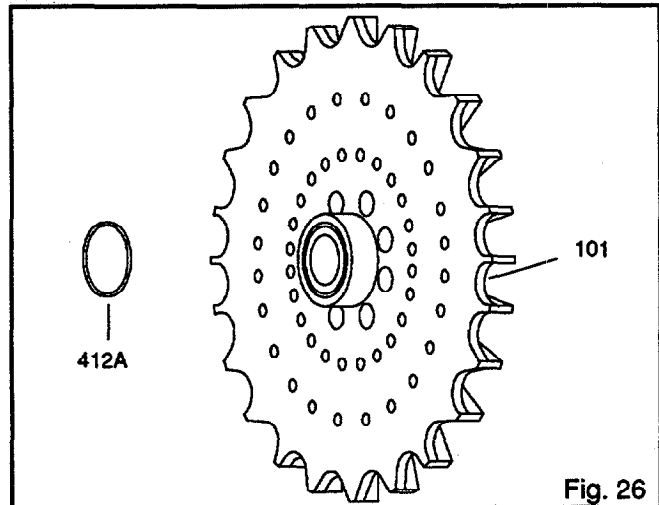

19. REMOVAL OF SEAL CHAMBER COVER (Mechanical Seal)

1. Remove gland stud nuts (355).
2. Remove seal chamber stud nuts (370H).
3. Remove seal chamber (184).

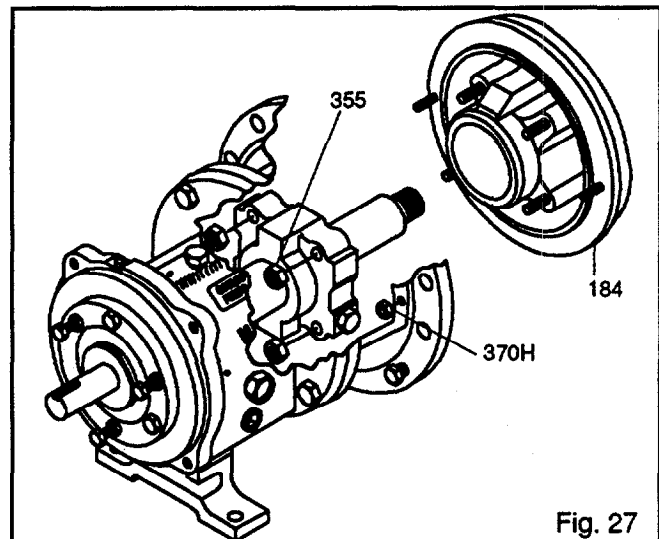

4. Remove shaft sleeve (126), if used.

NOTE Mechanical seal is attached to sleeve (126). Rotary portion of seal needs to be removed from sleeve by loosening set screws and sliding it off the sleeve. Refer to mechanical seal instructions.

5. Remove gland (107) with stationary seat and O-ring (360Q) (Fig. 28).

NOTE: Be careful not to damage the stationary portion of the mechanical seal. It is seated in the gland bore.

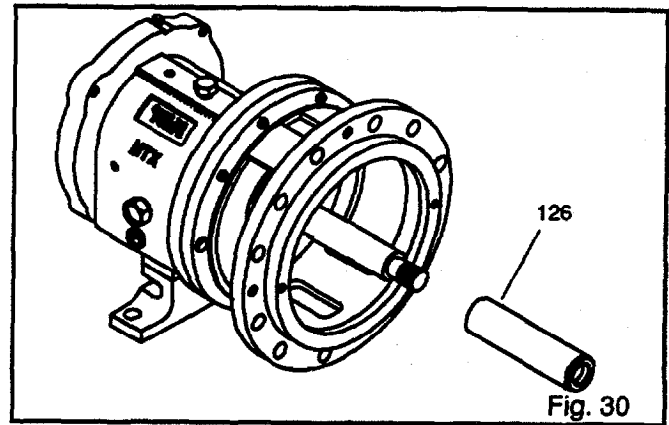
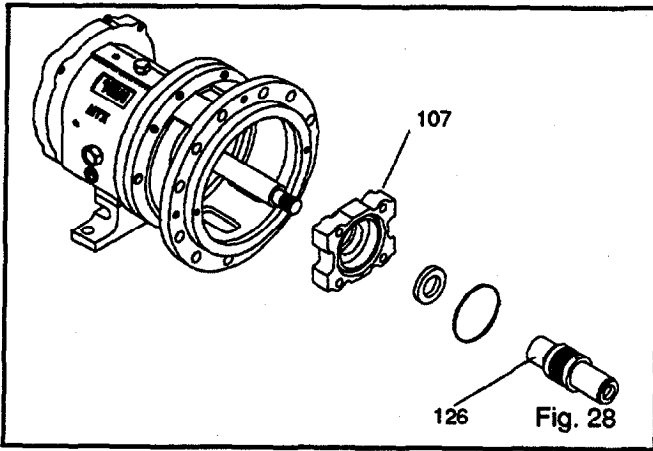

5. Remove packing (106) and lantern ring (105) from stuffing box cover (184) (Fig. 31).

19A. REMOVAL OF STUFFING BOX COVER
(Packed Box) (Fig. 29)

1. Remove gland stud nuts (355), and gland (107).
2. Remove stuffing box cover stud nuts (370H).
3. Remove stuffing box cover (184).

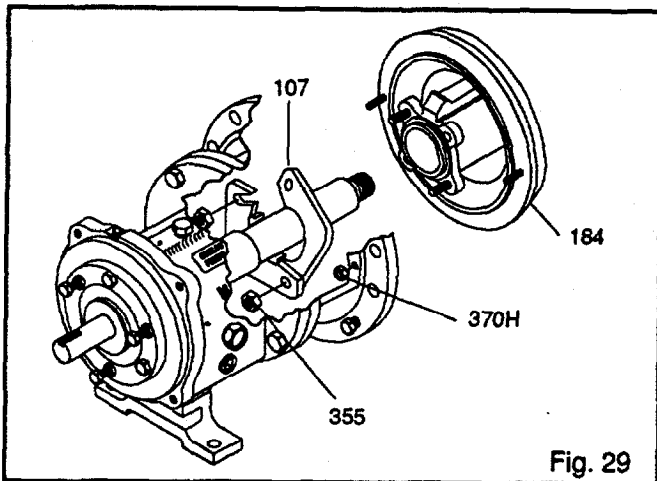
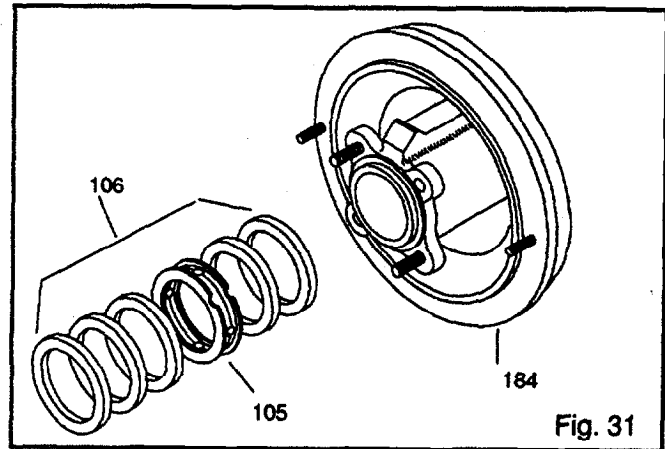

4. Remove shaft sleeve (126) (Fig. 30).

19B. REMOVAL OF DYNAMIC SEAL

1. Remove stud nuts (370H).
2. Remove dynamic seal assembly (Fig. 32).

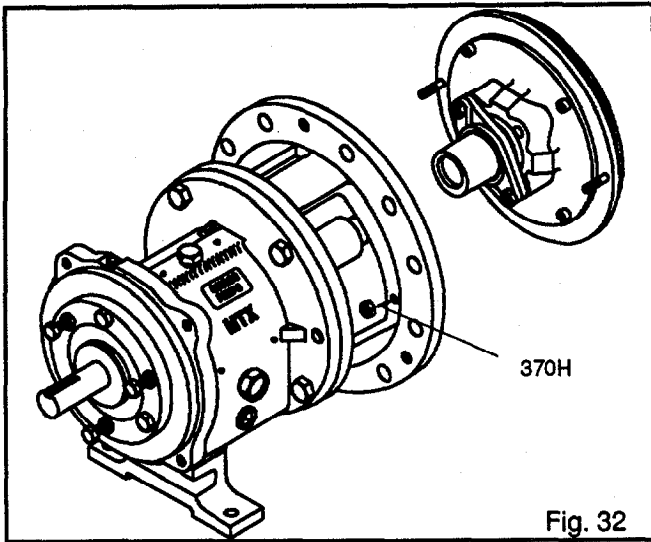

3. Remove socket head cap screws (265) (Fig. 33).
4. Remove stuffing box cover (184) and gasket (264).
5. Remove repeller (262) from backplate (444).

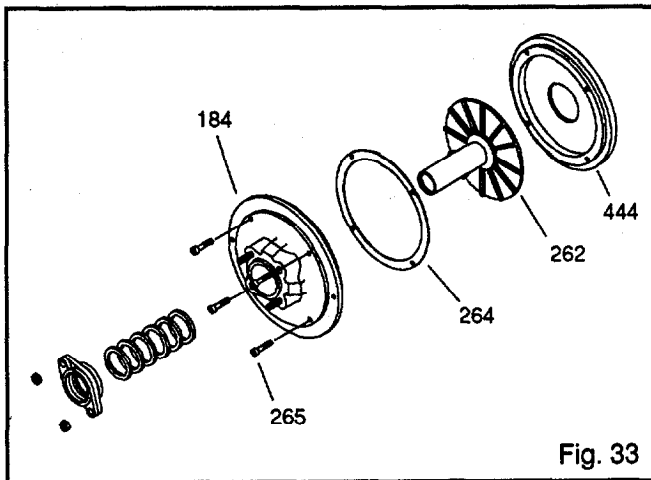

20. REMOVE FRAME ADAPTER - MTX, LTX

1. Remove dowel pins (469B), and bolts (370B).
2. Remove frame adapter (108) (Fig. 34).
3. Remove and discard gasket (360D). Replace with new gasket during reassembly.

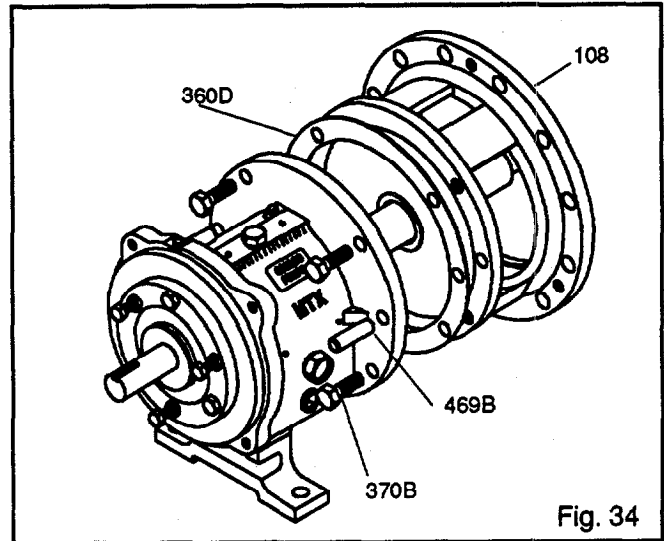

21. Remove inboard labyrinth oil seal (333A), it is an O-Ring fit into the bearing frame (228A) for STX, frame adapter (108) for MTX, and LTX. Remove O-rings (497H), (497J) if necessary (Fig. 35).

NOTE: Labyrinth oil seal O-rings (497H, J) are part of 3196 maintenance kits or can be obtained separately. (Use 3196 maintenance kit for LF 3196).

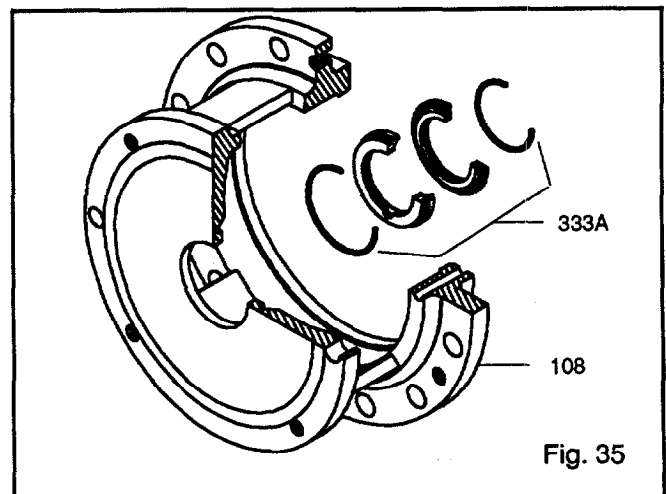

22A. DISASSEMBLY OF POWER END - STX, MTX

1. Remove clamp screws (370C). Back off jam nuts (423). Tighten jack screws (370D) evenly, this will start bearing housing (134) out of bearing frame (228A) (Fig. 36).
2. Remove the shaft assembly from the bearing frame (228A).

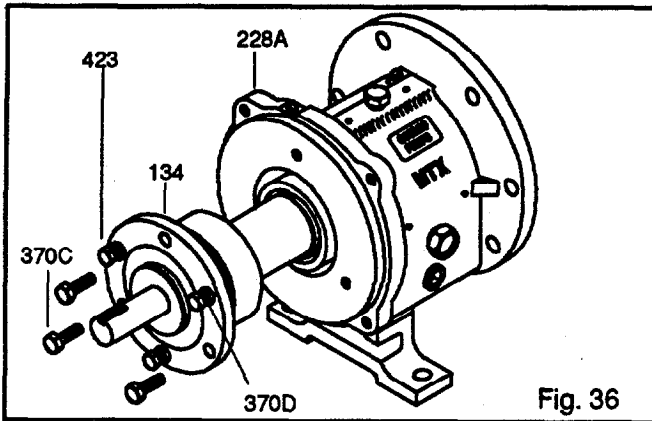

Fig. 36

3. Remove jack screws (370D) with nuts (423) (Fig. 37).
4. Remove bearing housing O-ring (469).
5. Remove outboard bearing retaining snap ring (316A).

NOTE: Snap ring cannot be removed from the shaft until bearings are removed.

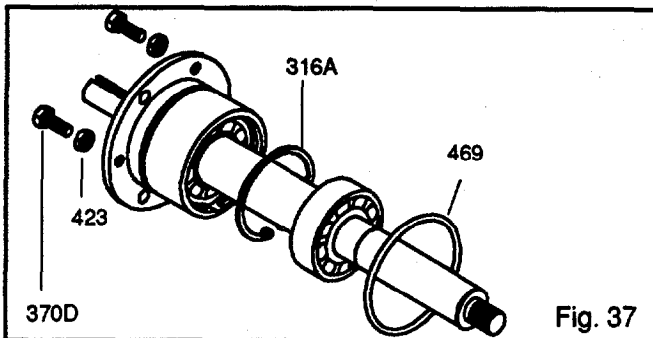

Fig. 37

6. Remove bearing housing (134) from shaft (122) with bearings (112A, 168A) (Fig. 38).

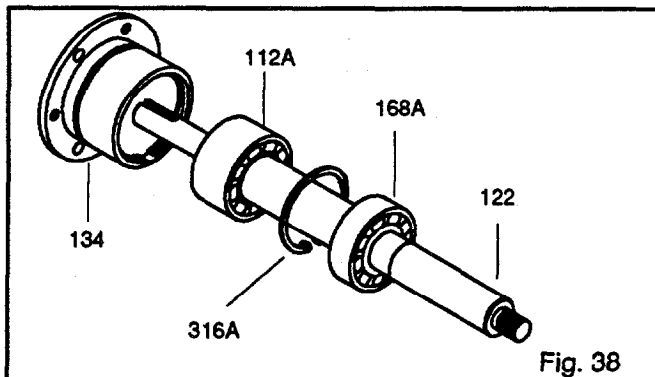

Fig. 38

7. Remove outboard labyrinth seal (332A) from bearing housing (134). Remove O-rings (497F), (497G) if necessary (Fig. 39).

NOTE: Labyrinth oil seal O-rings (497F, G) are part of 3196 maintenance kits or can be obtained separately. (Use 3196 maintenance kit for LF 3196).

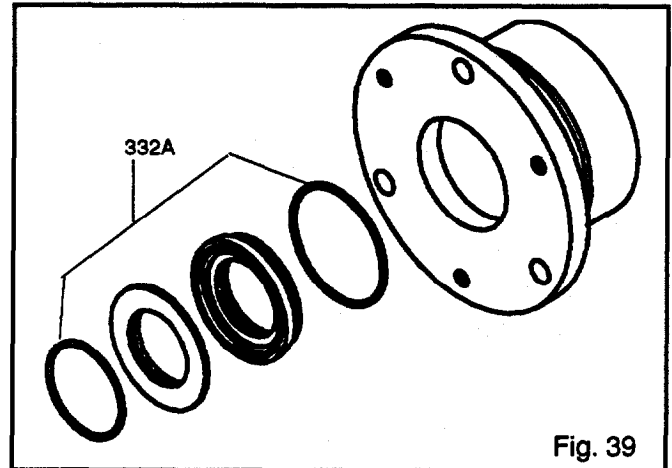

Fig. 39

8. Remove bearing locknut (136) and bearing lock washer (382) (Fig. 40).
9. Remove inboard bearing (168A).
10. Remove outboard bearing (112A).

NOTE: When pressing bearings off shaft, use force on inner race only.

NOTE: Save bearings for inspection.

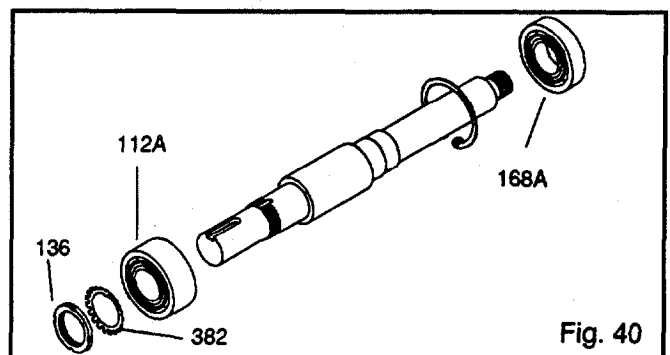

Fig. 40

22B. DISASSEMBLY OF POWER END - LTX

1. Remove clamp screws (370C). Back off jam nuts (423). Tighten jack screws (370D) evenly, this will start bearing housing (134) out of bearing frame (228A) (Fig. 41).
2. Remove shaft assembly from bearing frame (228A).

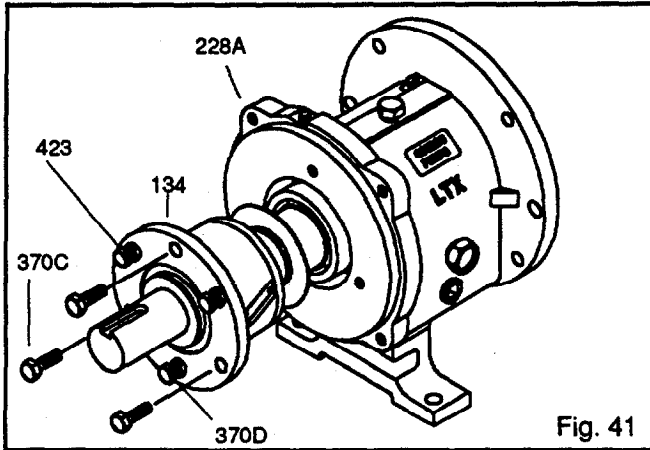

Fig. 41

3. Remove jack screws (370D) with nuts (423) (Fig. 42).
4. Remove clamp ring screws (236A). Separate clamp ring (253B) from bearing housing (134).

NOTE: Clamp ring cannot be removed from the shaft until bearings are removed.

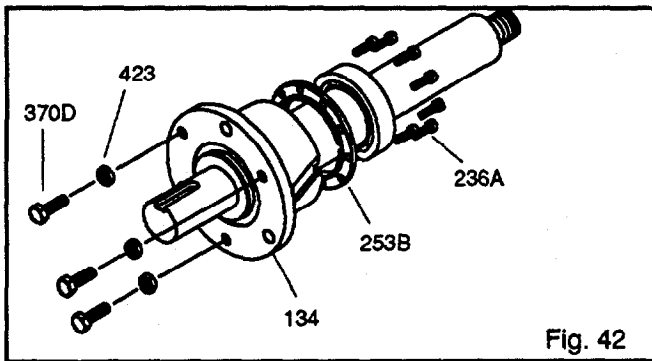

Fig. 42

5. Remove bearing housing (134) from shaft (122) with bearings (112A, 168A) (Fig. 43A).
6. Remove bearing housing O-ring (469).

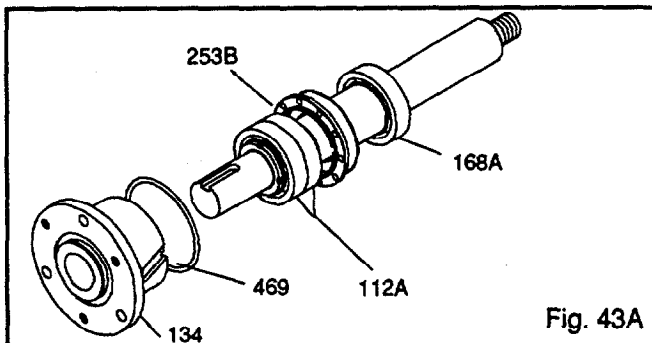

Fig. 43A

7. Remove inboard bearing (168A) (Fig. 43B).
8. Remove bearing locknut (136) and bearing lockwasher (382).
9. Remove outboard bearings (112A). Remove clamp ring (253B)

NOTE: When pressing bearings off shaft, use force on inner race only.

NOTE: Save bearings for inspection. Do not reuse bearings.

NOTE: Do not remove oil flinger (248A) unless it is damaged.

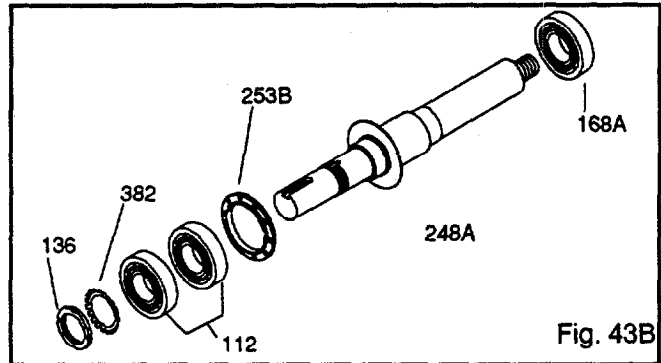

Fig. 43B

10. Remove outboard labyrinth seal (332A) from bearing housing (134). Remove O-rings (497F), (497G) if necessary (Fig. 44).

NOTE: Labyrinth oil seal O-rings (497F, G) are part of 3196 maintenance kits or can be obtained separately. (Use 3196 maintenance kit for LF 3196).

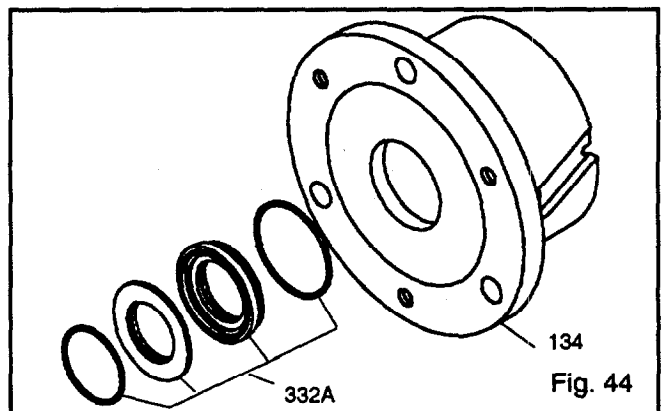
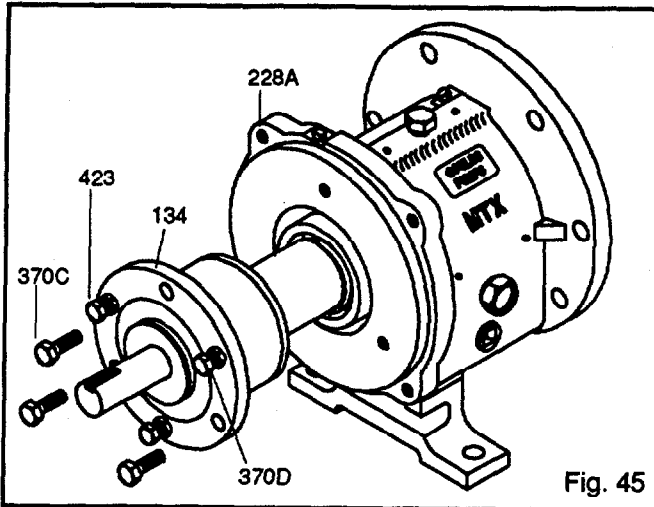

Fig. 44

22C. DISASSEMBLY OF POWER END - STX, MTX with Duplex Bearings

1. Remove clamp screws (370C). Back off jam nuts (423). Tighten jack screws (370D) evenly, this will start bearing housing (134) out of bearing frame (228A) (Fig. 45).
2. Remove shaft assembly from bearing frame (228A).



3. Remove jack screws (370D) with nuts (423) (Fig. 46).
4. Remove bearing housing O-ring (469).
5. Remove clamp ring screws (236A). Separate clamp ring (253B) from bearing housing (134).

NOTE: Clamp ring cannot be removed from the shaft until bearings are removed.

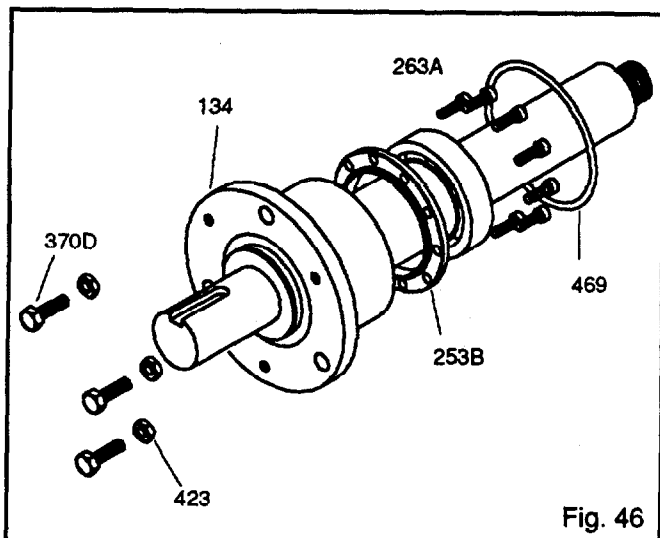

6. Remove bearing housing (134) from shaft (122) with bearings (112A, 168A) (Fig. 47).

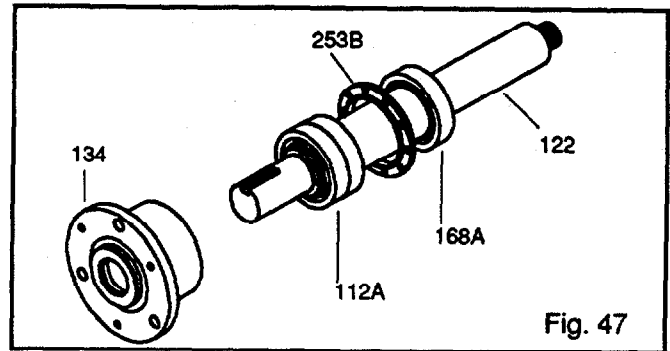

7. Remove inboard bearing (168A) (Fig. 48).
8. Remove bearing locknut (136) and bearing lockwasher (382).
9. Remove outboard bearings (112A).

NOTE: When pressing bearings off shaft, use force on inner race only.

NOTE: Save bearings for inspection.

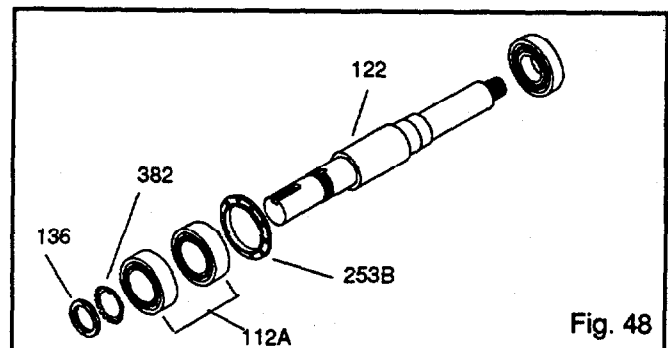

10. Remove outboard labyrinth seal (332A) from bearing housing (134). Remove O-rings (497F), (497G) if necessary (Fig. 49).

NOTE: Labyrinth oil seal O-rings (497F, G) are part of 3196 maintenance kits or can be obtained separately. (Use 3196 maintenance kit for LF 3196).

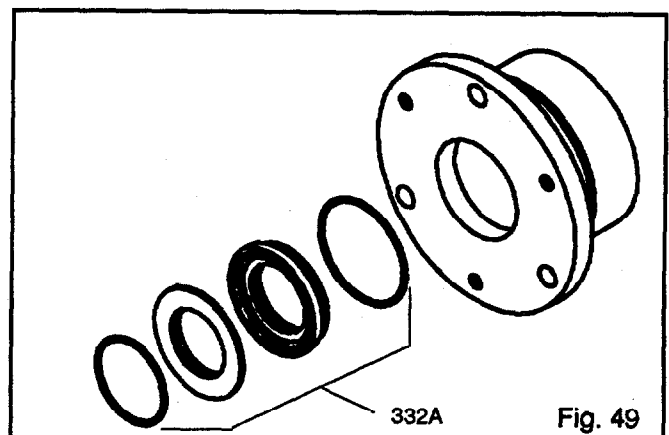

ALL MODELS

23. DISASSEMBLY OF BEARING FRAME

1. Remove oil fill plug (113A), oil drain plug (408A), sight glass (319), sight oiler plug (408J), four (4) oil mist/grease connection plugs (408H), and oil cooler inlet and outlet plugs (408L, 408M) from bearing frame (228A).
2. MTX, LTX: Remove bearing frame foot-to-frame bolts (370F), and frame foot (241).
3. Proceed to Parts Inspection.

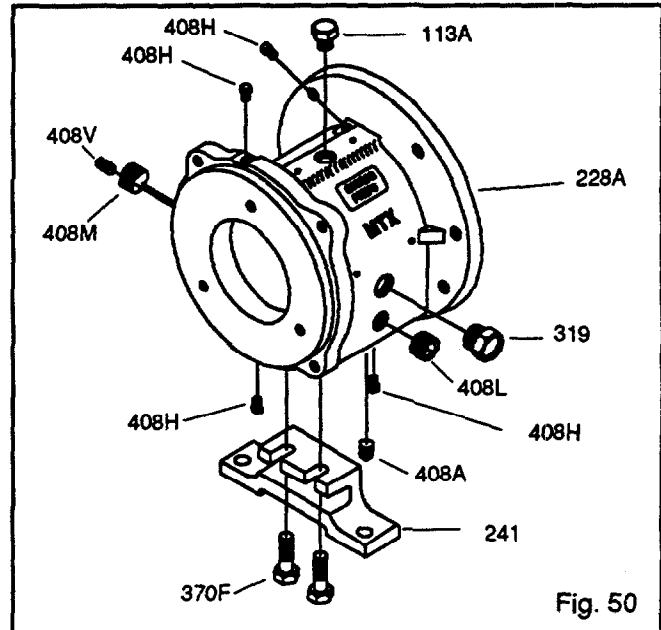

INSPECTIONS

The Model LF 3196 parts must be inspected to the following criteria before they are reassembled to insure the pump will run properly. Any part not meeting the required criteria should be replaced.

NOTE: Clean parts in solvent to remove oil, grease or dirt. Protect machined surfaces against damage during cleaning.

CASING

The casing (100) should be inspected for excessive wear or pitting. It should be repaired or replaced if it exceeds the following criteria (Fig. 51).

1. Localized wear or grooving greater than 1/8 in. (3.2 mm) deep.
2. Pitting greater than 1/8 in. (3.2 mm) deep.
3. Inspect case gasket seat surface for irregularities.

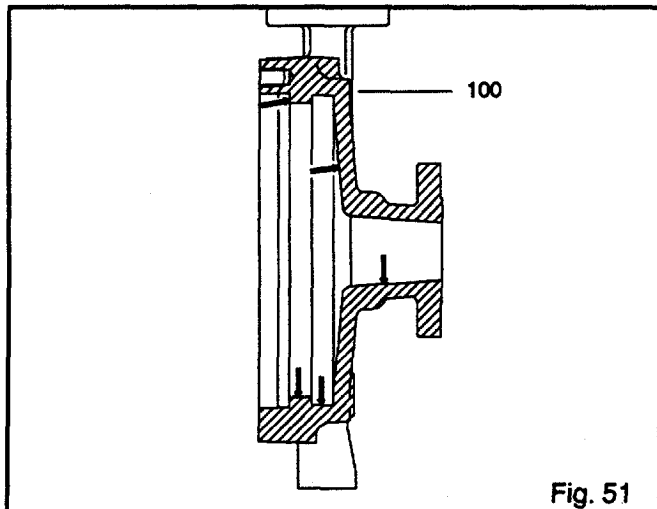

IMPELLER

1. Inspect impeller (101) vanes for damage. Replace if grooved deeper than 1/16 in. (1.6 mm) or if worn evenly more than 1/32 in. (0.8 mm). (Area "a" in Fig. 52)

2. Inspect leading and trailing edges of the vanes for pitting, and erosion or corrosion damage. (Area "c" in Fig. 62.).

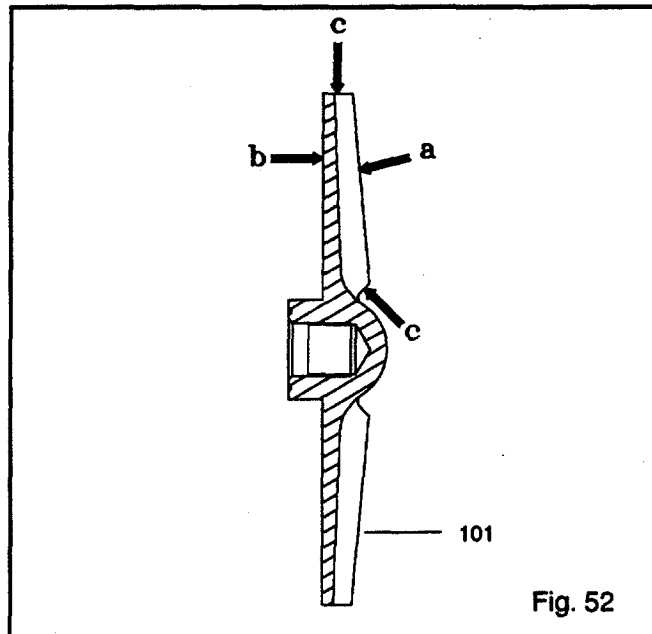

FRAME ADAPTER

1. Check frame adapter (108) for cracks or excessive corrosion damage. Replace if any of these conditions exist (Fig. 53).
2. Make sure gasket surface is clean.

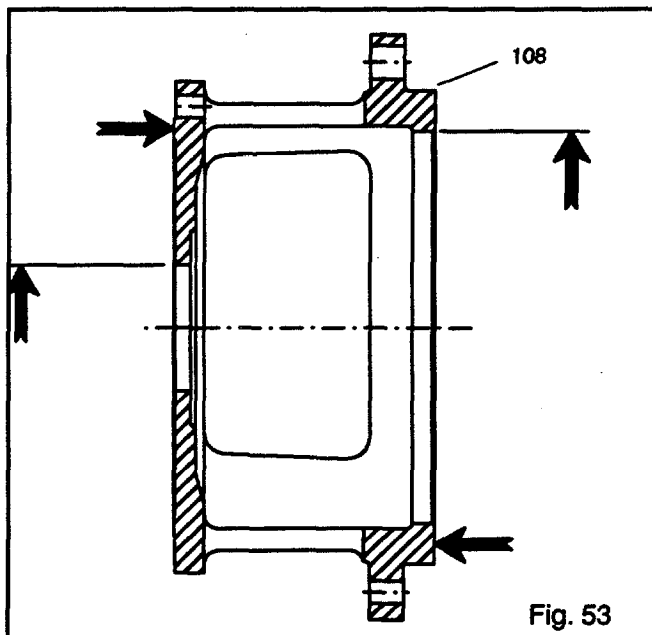

SHAFT AND SLEEVE

1. Check bearing fits. If any are outside the tolerance in Table 8, replace the shaft (122) (Fig. 54A).
2. Check shaft straightness. Replace shaft if runout exceeds values in Table 12.
3. Check shaft and sleeve (126) surface for grooves, pitting. Replace if any are found (Fig. 54B).

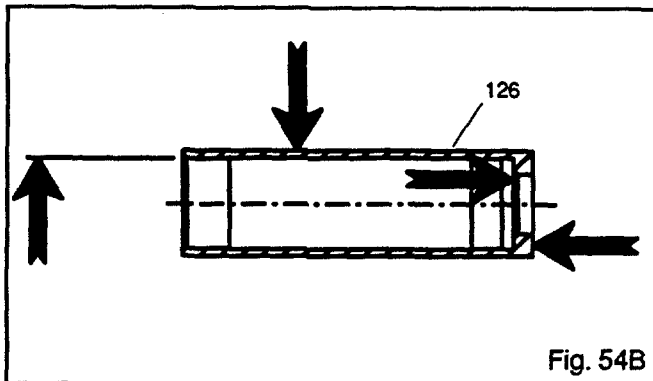
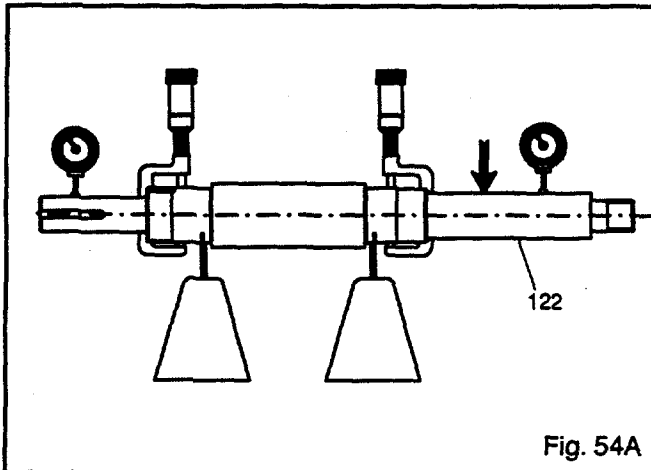

BEARING FRAME

1. Visually inspect bearing frame (228) and frame foot (241) for cracks. Check frame inside surfaces for rust, scale or debris. Remove all loose and foreign material (Fig. 55 and 56).
2. Make sure all lubrication passages are clear.
3. If frame has been exposed to pumpage inspect for corrosion or pitting.

4. Inspect inboard bearing bore according to Table 2.

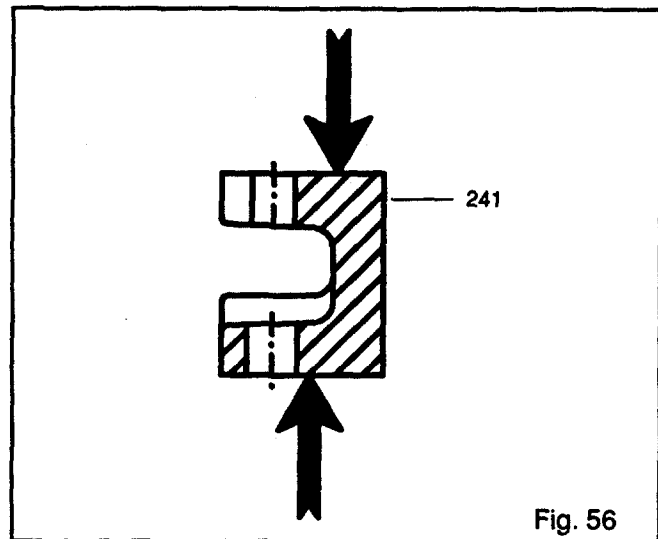
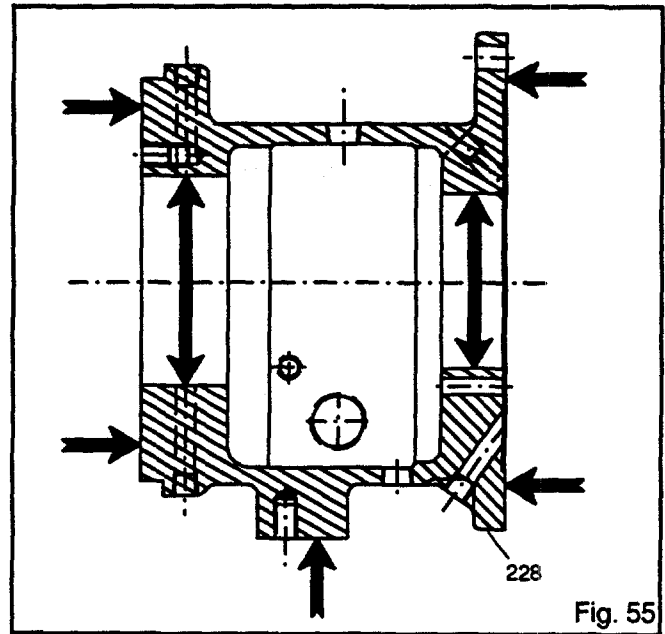

DYNAMIC SEAL REPELLER

1. Inspect dynamic seal repeller (262) vanes for damage. Replace if grooved deeper than 1/16 in. (1.6 mm) or if worn evenly more than 1/32 in. (0.8 mm) (Fig. 57).
2. Inspect sleeve surface for grooves, pitting or other damage. Replace if damaged.

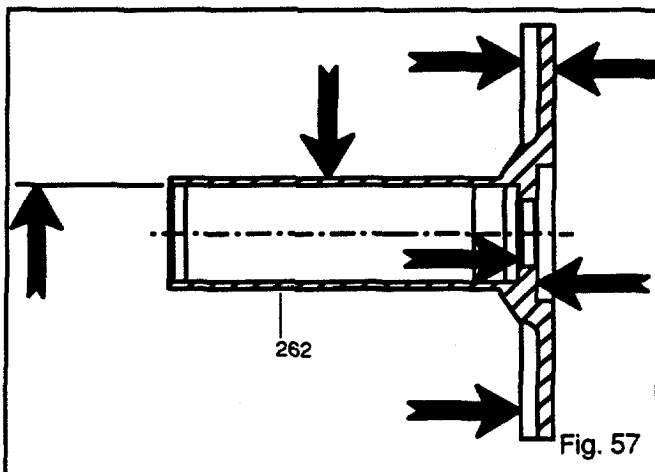

SEAL CHAMBER/STUFFING BOX COVER AND DYNAMIC SEAL BACKPLATE

1. Make sure seal chamber/stuffing box cover (184) and dynamic seal backplate (444) gasket surface is clean, at adapter face (Figs. 58, 59 and 60).
2. Replace if any pitting or wear greater than 1/8 in. (3.2 mm) deep.

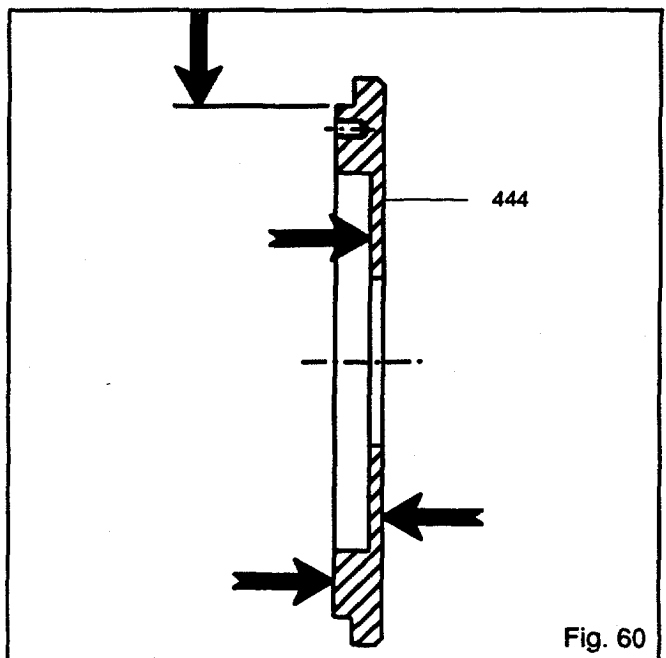
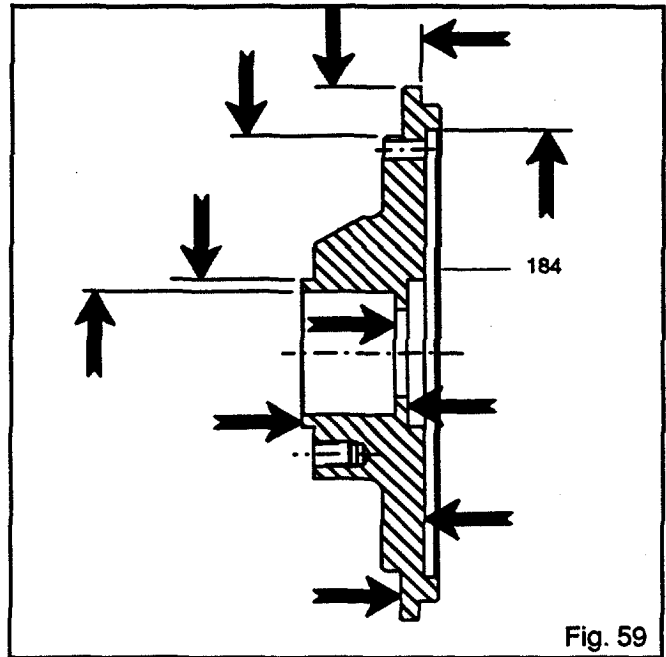
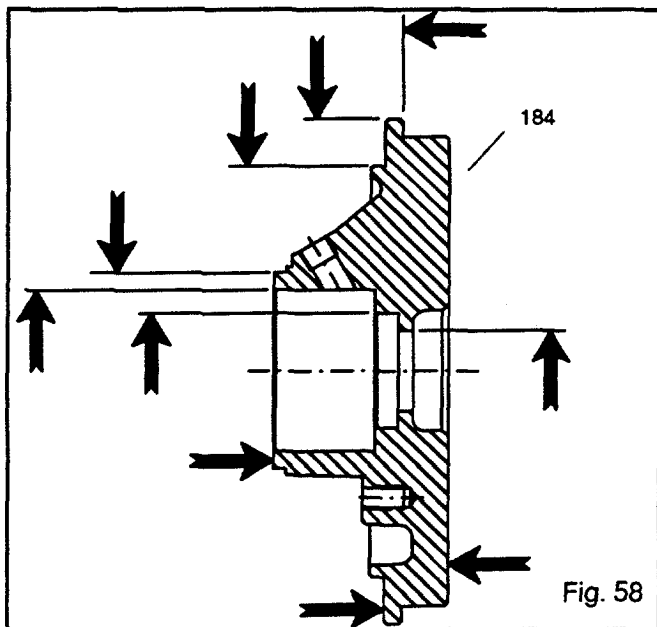

BEARINGS

1. Ball bearings (112A, 168A) should be inspected for contamination and damage. The condition of the bearings will provide useful information on operating conditions in the bearing frame. Lubricant condition and residue should be noted, oil analysis is often helpful. Bearing damage should be investigated to determine cause. If cause is not normal wear, it should be corrected before pump is returned to service.

DO NOT RE-USE BEARINGS.

BEARING HOUSING

1. Inspect bearing housing (134) bore according to Table 8. Replace if dimensions exceed Table 8 values.

2. Visually inspect for cracks and pits.

STX, MTX - Snap ring groove must not be cracked (Fig. 61).

LTX - Grooves and holes must be clear (Fig. 62).

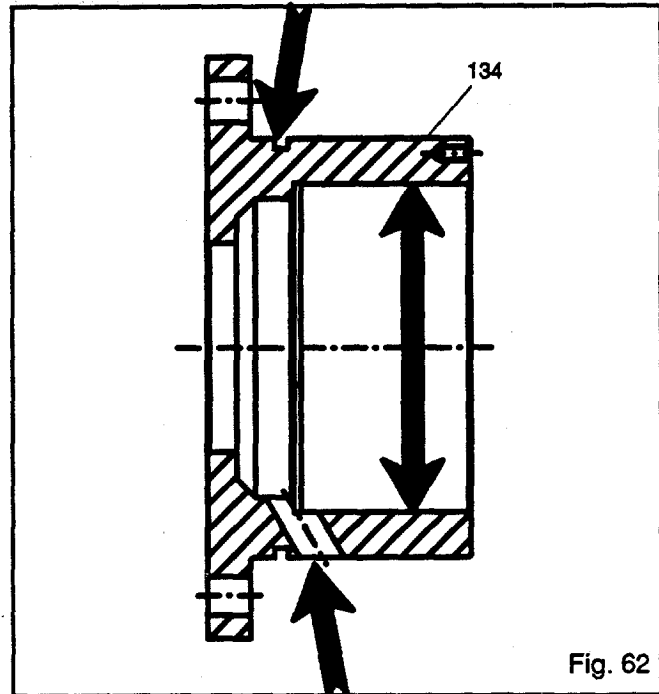
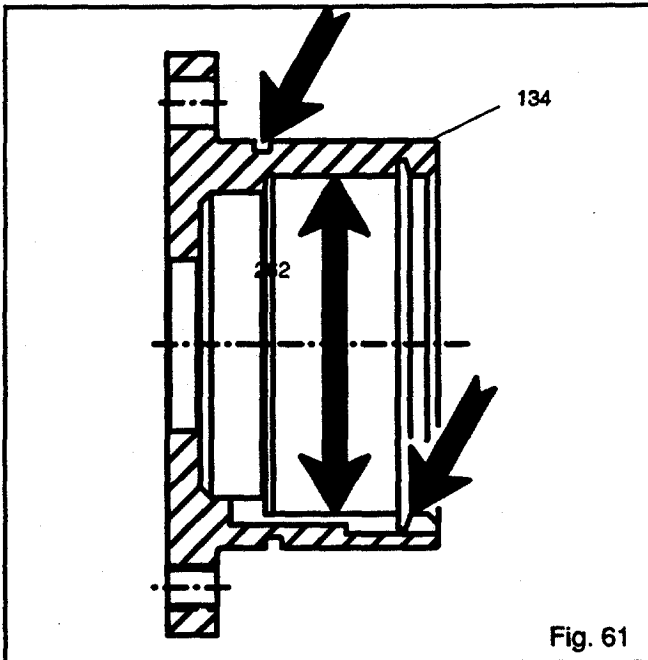

LABYRINTH SEALS

1. Labyrinth seal (332A, 333A) O-rings should be inspected for cuts and cracks. Replace as needed.

**Table 8
LF 3196 Bearing Fits & Tolerances**

| according to ABEC I standard | | | |
|------------------------------|--|--|--|
| | STX in. (mm) | MTX in. (mm) | LTX in. (mm) |
| Shaft O.D. Inboard | 1.3785 (35.013) | 1.7722 (45.013) | 2.1660 (55.015) |
| | 1.3781 (35.002) | 1.7718 (45.002) | 2.1655 (55.002) |
| | 0.0010 (0.025) tight 0.0001 (0.002) tight | 0.0010 (0.025) tight 0.0001 (0.002) tight | 0.0012 (0.030) tight 0.0001 (0.002) tight |
| Bearing I.D. Inboard | 1.3780 (35.000) | 1.7717 (45.000) | 2.1654 (55.000) |
| | 1.3775 (34.988) | 1.7712 (44.988) | 2.1648 (54.985) |
| Frame I.D. Inboard | 2.8346 (72.000) | 3.9370 (100.000) | 4.7244 (120.000) |
| | 2.8353 (72.019) | 3.9379 (100.022) | 4.7253 (120.022) |
| | 0.0012 (0.032) loose 0.0000 (0.000) loose | 0.0015 (0.037) loose 0.0000 (0.000) loose | 0.0015 (0.037) loose 0.0000 (0.000) loose |
| Bearing O.D. Inboard | 2.8346 (72.000) | 3.9370 (100.000) | 4.7244 (120.000) |
| | 2.8341 (71.987) | 3.9364 (99.985) | 4.7238 (119.985) |
| Shaft O.D. Outboard | 1.1815 (30.011) | 1.7722 (45.013) | 1.9690 (50.013) |
| | 1.1812 (30.002) | 1.7718 (45.002) | 1.9686 (50.002) |
| | 0.0008 (0.021) tight 0.0001 (0.002) tight | 0.0010 (0.025) tight 0.0001 (0.002) tight | 0.0010 (0.025) tight 0.0001 (0.002) tight |
| Bearing I.D. Outboard | 1.1811 (30.000) | 1.7717 (45.000) | 1.9685 (50.000) |
| | 1.1807 (29.990) | 1.7712 (44.988) | 1.9680 (49.988) |
| Housing I.D. Outboard | 2.8346 (72.000) | 3.9370 (100.000) | 4.3307 (110.000) |
| | 2.8353 (72.019) | 3.9379 (100.022) | 4.3316 (110.022) |
| | 0.0012 (0.032) loose 0.0000 (0.000) loose | 0.0015 (0.037) loose 0.0000 (0.000) loose | 0.0015 (0.037) loose 0.0000 (0.000) loose |
| Bearing O.D. Outboard | 2.8346 (72.000) | 3.9370 (100.000) | 4.3307 (110.000) |
| | 2.8341 (71.987) | 3.9364 (99.985) | 4.3301 (109.985) |

REASSEMBLY

Refer to Table 9 for torque values while reassembling pump.

| Table 9 | | | |
|---|-------------------|--------------------|--------------------|
| Bolt Torque Table | | | |
| LOCATION | | LUBRICATED THREADS | DRY THREADS |
| CASING BOLTS (370) | 4" STX | 30 FT-LBS (40 Nm) | 45 FT-LBS (60 Nm) |
| | 8" STX | 20 FT-LBS (27 Nm) | 30 FT-LBS (40 Nm) |
| | 10", 13" MTX, LTX | 30 FT-LBS (40 Nm) | 45 FT-LBS (60 Nm) |
| FRAME-TO-ADAPTER BOLTS (370B) | | 20 FT-LBS (27 Nm) | 30 FT-LBS (40 Nm) |
| BEARING CLAMP RING BOLTS (236A) Duplex Bearing Only | STX, MTX | 10 IN-LBS (1.1 Nm) | 17 IN-LBS (1.9 Nm) |
| | LTX | 55 IN-LBS (6.2 Nm) | 83 IN-LBS (9.4 Nm) |
| DYNAMIC SEAL CAP SCREWS | STX, MTX, LTX | 55 IN-LBS (6.2 Nm) | 83 IN-LBS (9.4 Nm) |

Refer to Table 10 for shaft end play while reassembling pump.

| Table 10 | | | |
|-------------------------------|-----------------|-----------------|-----------------|
| LF 3196 Shaft End Play | | | |
| | STX in. (mm) | MTX in. (mm) | LTX in. (mm) |
| Double Row | .0011 (.028) | .0013 (.033) | not |
| | .0019 (.047) | .0021 (.054) | applicable |
| Duplex | .0007 (.018) | .0009 (.022) | .0010 (.026) |
| | .0010 (.026) | .0012 (.030) | .0015 (.038) |

**Table 11
LF 3196 Bearing Type**

| Frame | Inboard | Outboard | |
|------------|---------|----------------|------------|
| | | Double Row | Duplex |
| STX | 6207 | 5306A / C3 | 7306 BECBM |
| MTX | 6309 | 5309A / C3 | 7309 BECBM |
| LTX | 6311 | not applicable | 7310 BECBM |
| XLT-X, X17 | 6313 | 5313A / C3 | 7313 BECBM |

**Table 12
LF 3196 Shaft Runout Tolerances**

| | Sleeve Fit in. (mm) | Coupling Fit in. (mm) |
|-------------|------------------------|--------------------------|
| With Sleeve | .001 (.026) | .001 (.026) |
| Less Sleeve | .002 (.051) | .001 (.026) |

Note: Bearing type is based on SKF/MRC designation.

ASSEMBLY OF ROTATING ELEMENT AND BEARING FRAME

STX, MTX

NOTE: Make sure that threads are clean and apply thread sealant to pipe threads and fittings.

1. Install oil fill plug (113A), oil drain plug (408A), sight window (319), sight oiler plug (408J), 4 oil mist connection plugs (408H) or grease fittings (193) and relief plugs (113), and oil cooler inlet and outlet plugs (408L, 408M) in bearing frame (228) (Fig. 63).
2. Attach bearing frame foot (241) with bolts (370F). Hand tighten.

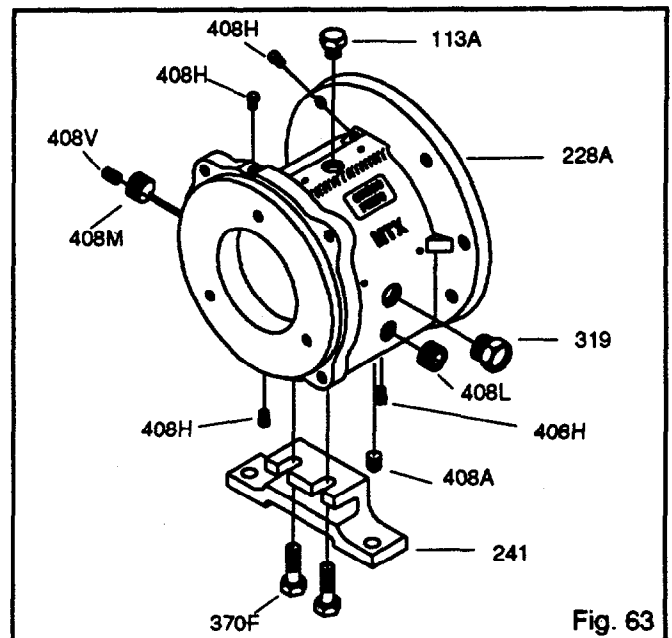

Fig. 63

3. Install outboard bearing (112A) on shaft (122) (Fig. 64).

NOTE: Regreaseable bearing has a single shield. The outboard bearing is installed with shield toward impeller.

NOTE: There are several methods used to install bearings. The recommended method is to use an induction heater that heats as well as demagnetizes the bearings.

WARNING

Use insulated gloves when using a bearing heater. Bearing will get hot and can cause physical injury.

4. Place lockwasher (382) on shaft (122). Place tang of lockwasher in keyway of shaft.
5. Thread locknut (136) onto shaft (122). Tighten locknut until snug. Bend any tang of lockwasher into a slot of locknut.

NOTE: Tighten locknut if necessary to align the closest tab of lockwasher with slot on locknut.

6. Place bearing retaining ring (361A) over shaft (122), flat side facing bearing.
7. Install inboard bearing (168A) on shaft (122).

NOTE: Regreaseable bearing has a single shield. The inboard bearing is installed with shield away from impeller.

NOTE: There are several methods used to install bearings. The recommended method is to use an induction heater that heats as well as demagnetizes the bearings.

WARNING

Use insulated gloves when using a bearing heater. Bearing will get hot and can cause physical injury.

NOTE: Coat internal surfaces of bearings with lubricant to be used in service.

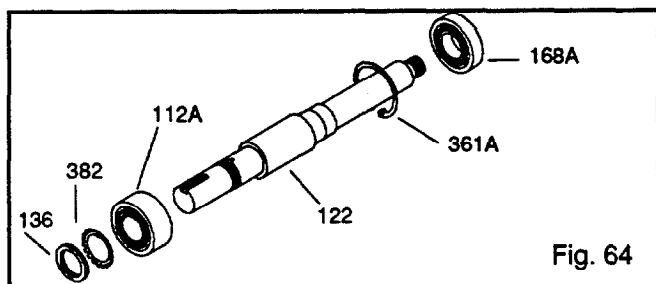

8. Install new O-ring (496) (Fig. 65).
9. Coat outside of outboard bearing (112A) and bearing housing (134) bore with oil.
10. Install bearing housing (134) onto shaft/bearing assembly.

NOTE: Do not force assembly together.

11. Insert retaining ring (361A) into groove in housing (134) bore. Check shaft for free turning.

NOTE: The space between the ends of retaining ring should be located in the oil return groove so as not to obstruct oil flow.

12. Install outboard labyrinth oil seal (332A) into bearing housing (134). It is an O-Ring fit. Position the labyrinth seal drain slots at the bottom (6 o'clock) position.

NOTE: Make sure the keyway edges are free of burrs.

NOTE: Cover the keyway lengthwise with a piece of electrical tape prior to installing the labyrinth seal. This will protect the O-rings.

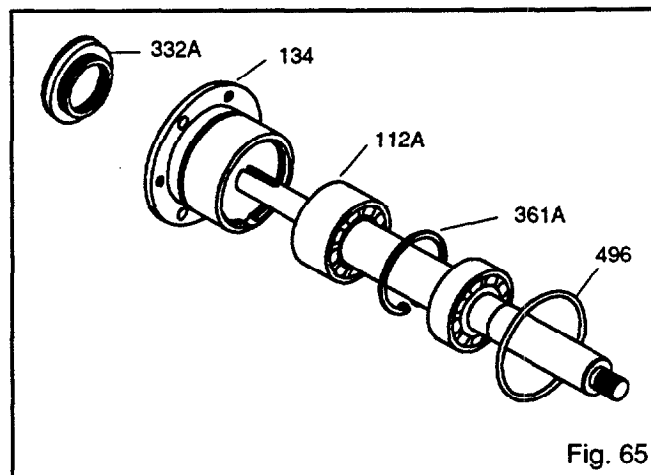

13. Coat outside of bearing housing (134) with oil (Fig. 66).
14. Coat all internal surfaces of bearing frame (228A) with oil.
15. Install shaft assembly into frame (228A). Check shaft for free turning.
16. Install clamping bolts (370C) into bearing housing (134). Hand tighten.

17. Install jacking bolts (370D) with locking nuts (423) into housing (134). Hand tighten.

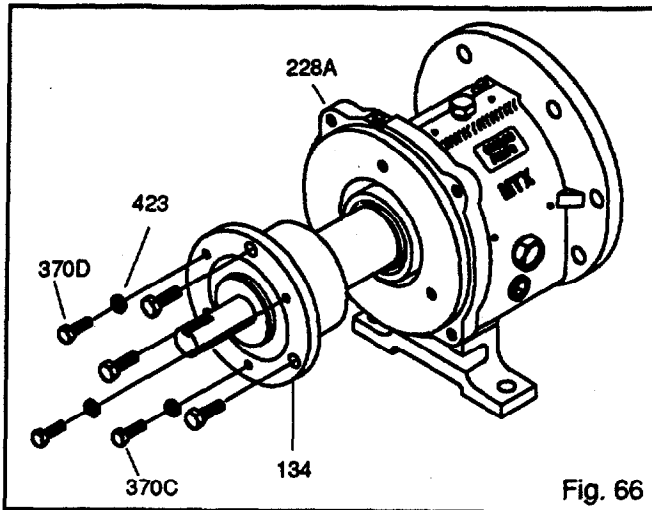

LTX

NOTE: Make sure that threads are clean and apply thread sealant to pipe threads and fittings.

1. Install the oil fill plug (113A), oil drain plug (408A), sight window (319), sight oiler plug (408J), 4 oil mist connection plugs (408H) or grease fittings (193) and grease relief plugs (113), and oil cooler inlet and outlet plugs (408L, 408M) in bearing frame (228). (Fig. 67)
2. Attach bearing frame foot (241) with bolts (370F). Hand tighten.

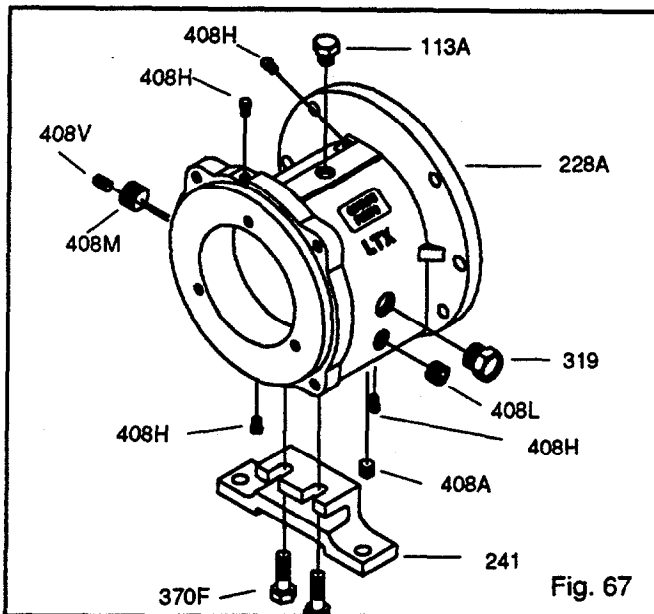

3. Install oil flinger (248A) on shaft (122) if removed. (Fig. 68)

NOTE: The oil flinger is a press fit onto shaft. Use a driver of proper size to prevent damage to oil flinger.

4. Place bearing clamp ring (253B) over shaft (122). Note orientation.
5. Install outboard bearings (112A) on shaft (122).

CAUTION

The LTX uses duplex bearings mounted back to back. Make sure orientation of the bearings is correct.

NOTE: There are several methods used to install bearings. The recommended method is to use an induction heater that heats as well as demagnetizes the bearings.

WARNING

Use insulated gloves when using a bearing heater. Bearing will get hot and can cause physical injury.

6. Place lockwasher (382) on shaft (122). Place tang of lockwasher in keyway of shaft.
7. Thread locknut (136) onto shaft (122). Tighten locknut until snug. Bend any tang of lockwasher (382) into a slot of locknut.

NOTE: Tighten locknut if necessary to align the closest tab of lockwasher with slot on locknut.

8. Install inboard bearing (168A) on shaft (122).

NOTE: Regreaseable bearing has a single shield. The inboard bearing is installed with shield away from impeller.

NOTE: There are several methods used to install bearings. The recommended method is to use an induction heater that heats as well as demagnetizes the bearings.

WARNING

Use insulated gloves when using a bearing heater. Bearing will get hot and can cause physical injury.

NOTE: Coat internal surfaces of bearings with lubricant to be used in service.

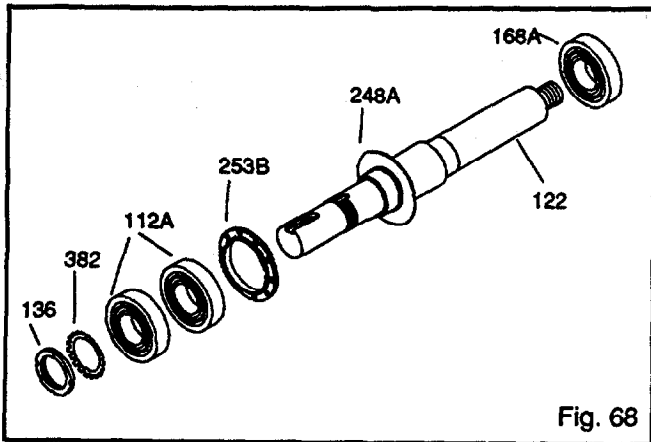

Fig. 68

9. Coat outside of outboard bearing (112A) and bearing housing (134A) bore with oil.
10. Install bearing housing (134) onto shaft/bearing assembly (Fig. 69).

NOTE: Do not force assembly together.

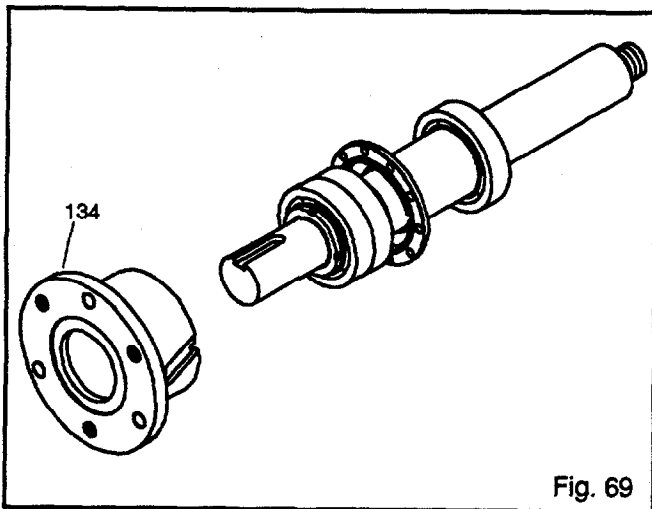

Fig. 69

11. Install clamp ring bolts (236A). Check shaft for free turning. Refer to Table 9 for bolt torque values (Fig. 70).

CAUTION

Tighten clamp ring bolts (236A) in a crisscross pattern.

12. Install new O-ring (496).
13. Install outboard labyrinth oil seal (332A) into bearing housing (134). It is an O-Ring fit. Position the labyrinth seal drain slots at the bottom (6 o'clock) position.

NOTE: Make sure the keyway edges are free of burrs.

NOTE: Cover the keyway lengthwise with a piece of electrical tape prior to installing the labyrinth seal. This will protect the O-rings.

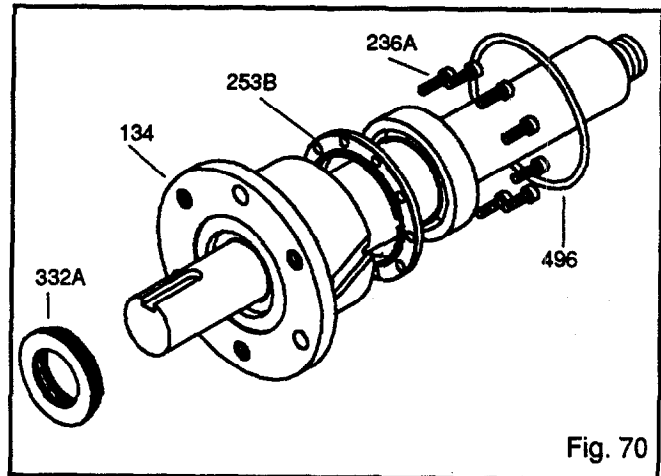

Fig. 70

14. Coat outside of bearing housing (134A) with oil.
15. Coat all internal surfaces of bearing frame (228) with oil.
16. Install shaft assembly into frame (228A). Check shaft for free turning.
17. Install clamping bolts (370C) into bearing housing (134A). Hand tighten.
18. Install jacking bolts (370D) with locking nuts (423) into housing (134A). Hand tighten.

6

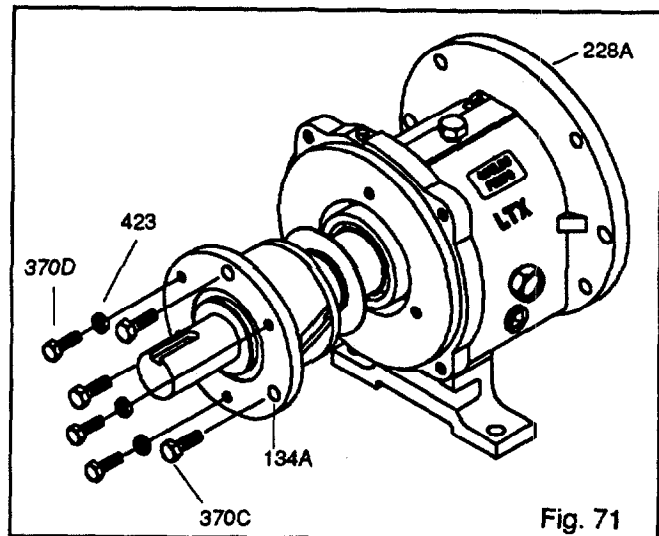

Fig. 71

STX, MTX WITH DUPLEX BEARINGS

1. Install the oil fill plug (113A), oil drain plug (408A), sight window (319), sight oiler plug (408J), 4 oil mist connection plugs (408H), or grease fittings (193) and grease relief plugs (113), and oil cooler inlet and outlet plugs (408L, 408M) in bearing frame (228) (Fig. 90).
2. Attach bearing frame foot (241) with bolts (370F). Hand tighten (Fig. 72).

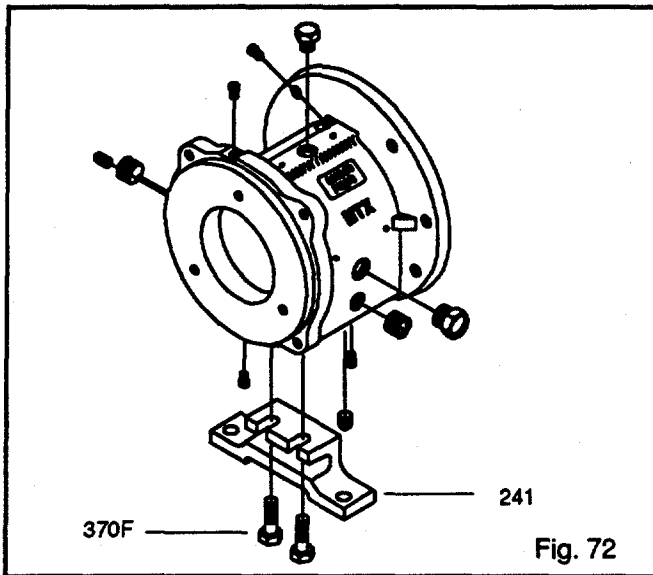

Fig. 72

NOTE: There are several methods used to install bearings. The recommended method is to use an induction heater that heats as well as demagnetizes the bearings.

WARNING

Use insulated gloves when using a bearing heater. Bearings will get hot and can cause physical injury.

3. Install outboard bearings (112A) on shaft (122).

CAUTION

Duplex bearings are mounted back to back. Make sure orientation of bearings are correct.

4. Place lockwasher (382) on shaft (122). Place tang of lockwasher in keyway of shaft (Fig. 73).
5. Thread locknut (136) onto shaft (122). Tighten locknut until snug. Bend any tang of lockwasher (382) into a slot of locknut.

NOTE: Tighten locknut if necessary to align the closest tab of lockwasher with slot on locknut.

6. Place bearing clamp ring (253B) over shaft (122). Note orientation.

7. Install inboard bearing (168A) on shaft (122).

NOTE: Regreaseable bearing has a single shield. The inboard bearing is installed with shield away from impeller.

NOTE: Coat internal surfaces of bearings with lubricant to be used in service.

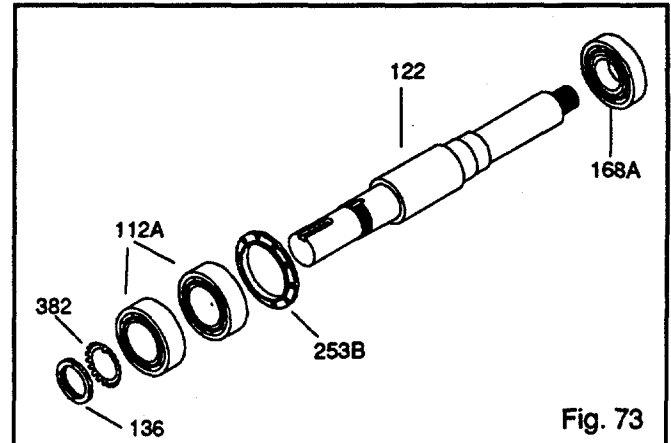

Fig. 73

8. Coat outside of outboard bearing (112A) and bore of bearing housing (134) with oil.
9. Lower shaft/bearing assembly into bearing housing (134) (Fig. 74).

NOTE: Do not force assembly together.

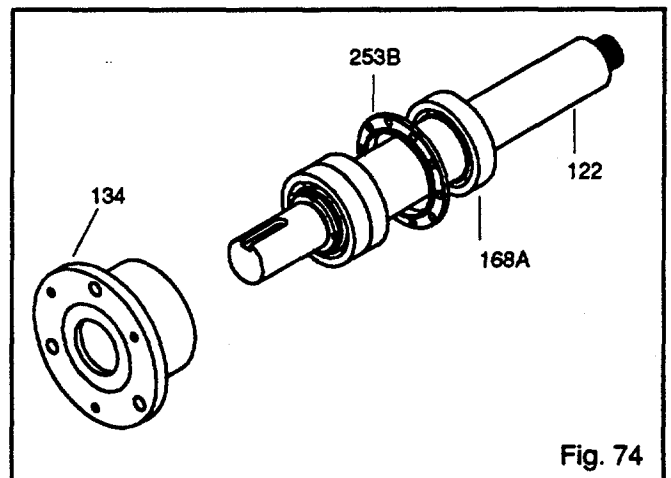
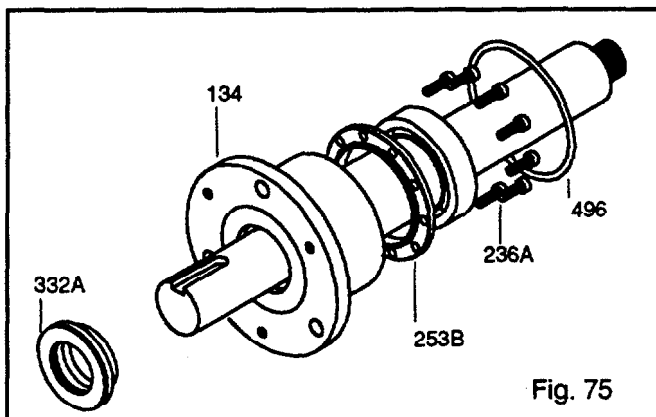

Fig. 74

10. Install clamp ring (253B) with bolts (236A). Tighten bolts in a crisscross pattern. Check shaft for free turning. Refer to Table 9 for bolt torque values (Fig. 93).
11. Install new O-ring (496).
12. Install outboard labyrinth oil seal (332A) into bearing housing (134). It is an O-ring fit. Position the labyrinth seal drain slots at the bottom 6 o'clock position (Fig. 75).

NOTE: Make sure the keyway edges are free of burrs.

NOTE: Cover the keyway lengthwise with a piece of electrical tape prior to installing the labyrinth seal. This will protect the O-rings.



13. Coat outside of bearing housing (134) with oil.
14. Coat all internal surfaces of bearing frame (228A) with oil.
15. Install shaft assembly into frame (228A). Check shaft for free turning (Fig. 76).
16. Install clamping bolts (370C) into bearing housing (134A). Hand tighten.
17. Install jacking bolts (370D) with locking nuts (423) into housing (134A). Hand tighten.

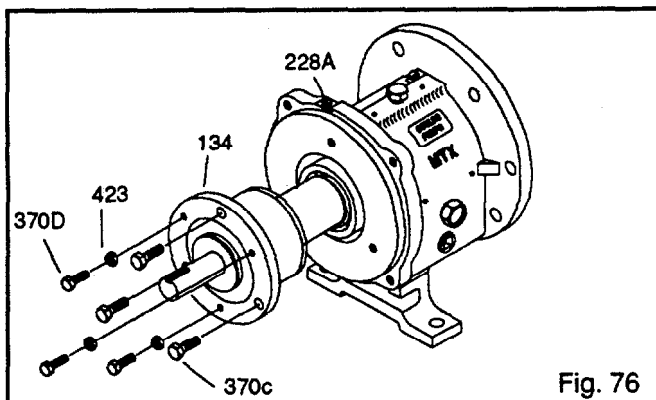

ALL MODELS STX, MTX, LTX

1. Support frame assembly in horizontal position.
2. Check shaft end play. Move shaft forward then backward by hand, noting indicator movement. If total indicator reading is greater than Table 10, page 51, values, disassemble and determine cause (Fig. 77).

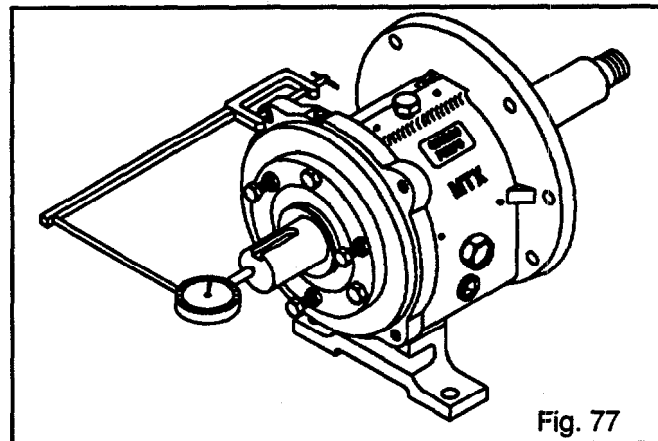

Fig. 77

3. Check shaft/sleeve runout. Put on shaft sleeve (126) if used, and thread on impeller, hand tight. Rotate shaft 360 degrees. If total indicator reading is greater than .002 in., disassemble and determine cause. Remove impeller and shaft sleeve (Fig. 78).

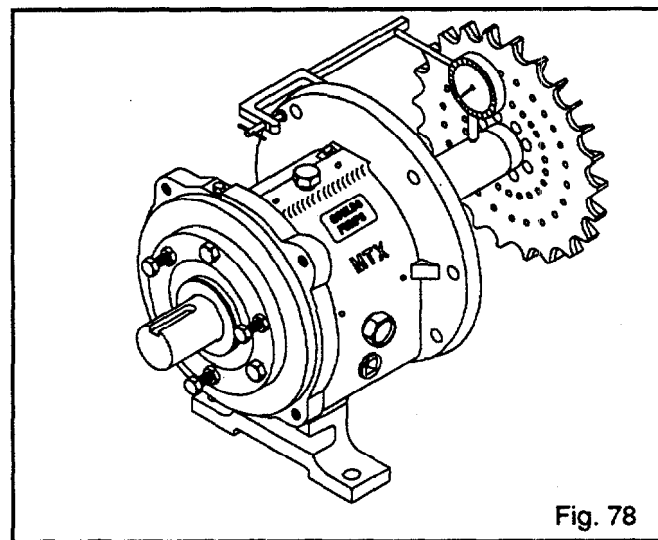

Fig. 78

4. Check frame face run out. Rotate shaft so indicator rides along the fit for 360 degrees. If total indicator reading is greater than 0.001 in. (.025 mm) disassemble and determine cause (Fig. 79).

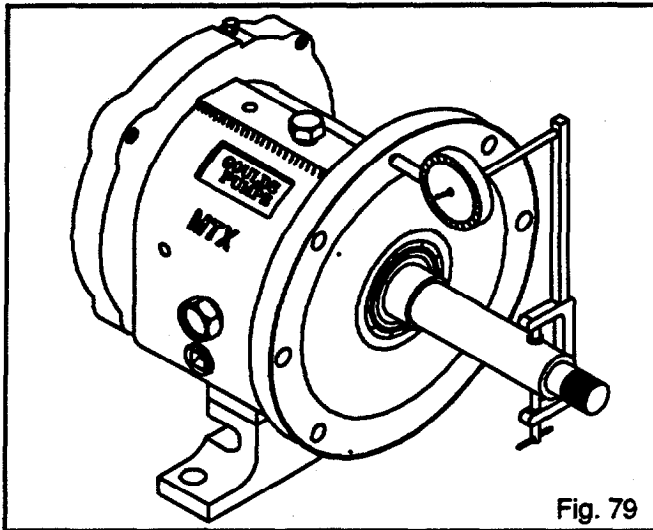

Fig. 79

- Place manila gasket (360D) on frame (228) (Fig. 80).

NOTE: The gasket is designed to fit one way only. The dowel pins (469B) may be started in their holes to hold the gasket in place.

- Install frame adapter (108), onto frame assembly. Align bolt holes and dowel locations with those on frame (Fig. 80).
- Install dowel pins (469B), and bolts (370B). Tighten bolts to Table 9, page 52, torque specifications, in a crisscross pattern.

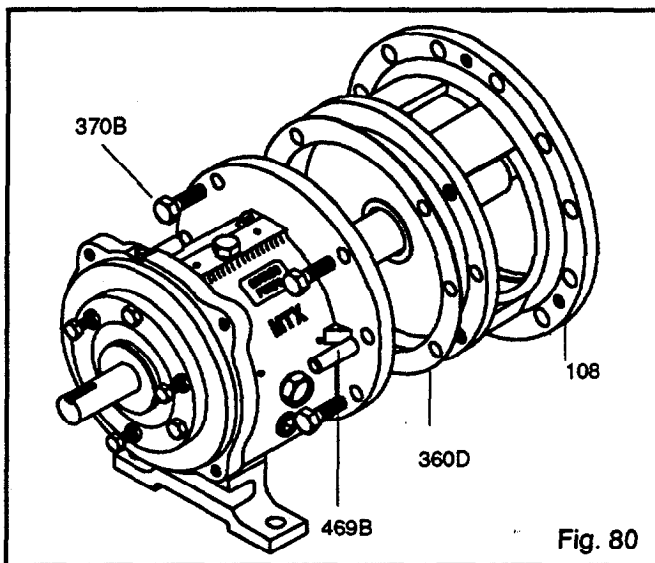

Fig. 80

- Check adapter fits. Rotate shaft thru 360 degrees. If total indicator reading is greater than .005 in. (.13 mm), determine the cause and correct before proceeding (Fig. 81).

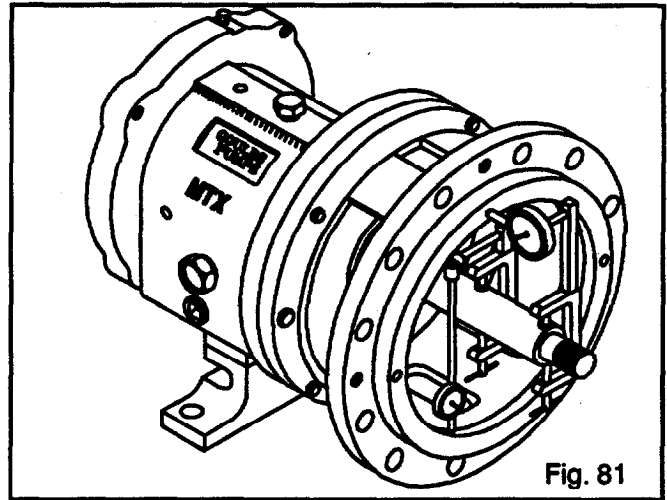

Fig. 81

- Install inboard labyrinth oil seal (333A) into adapter (108) / bearing frame (228). It is an O-Ring fit. Position the labyrinth seal drain slots at the bottom (6 o'clock) position. (Fig. 82A, 82B)

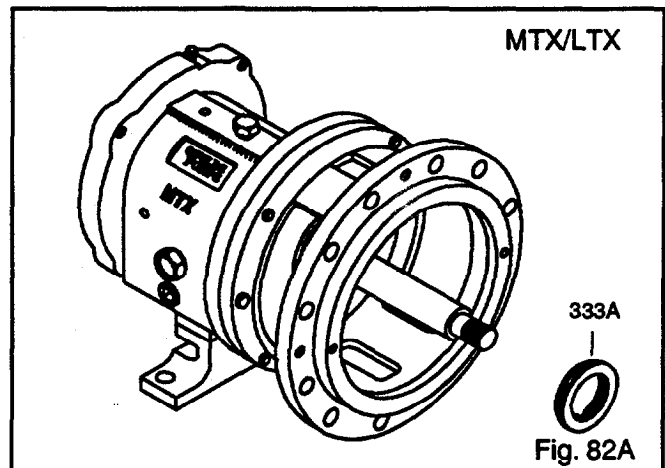

Fig. 82A

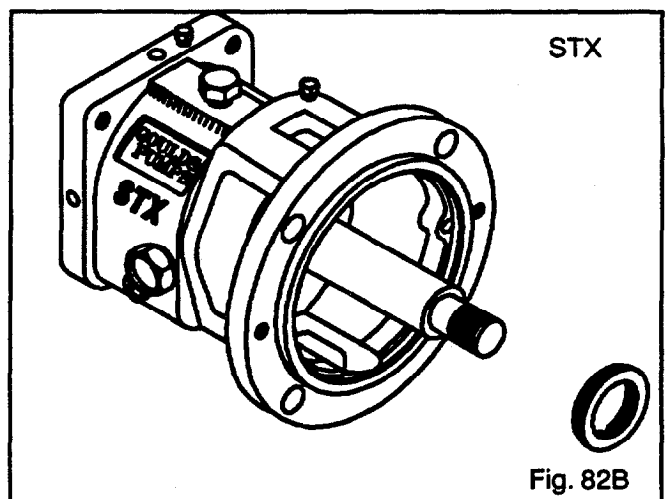

Fig. 82B

Pumps With Mechanical Seals:

1. Install seal chamber cover (184) with nuts (370H).

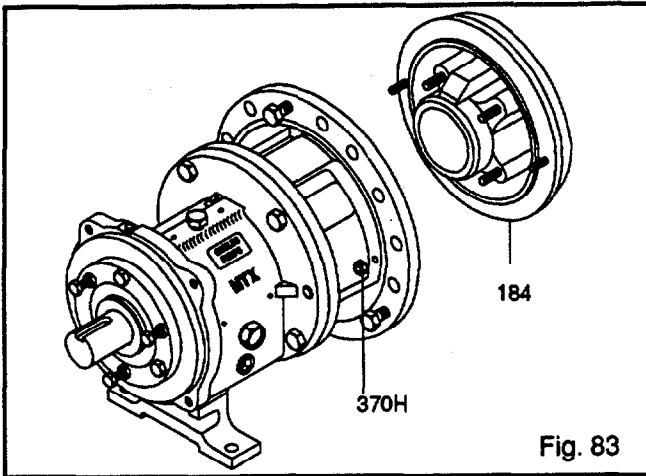

Fig. 83

2. Check seal chamber cover run-out. Rotate indicator thru 360 degrees. If total indicator reading is greater than 0.005 in. (.13 mm), determine cause and correct before proceeding (Fig. 84).

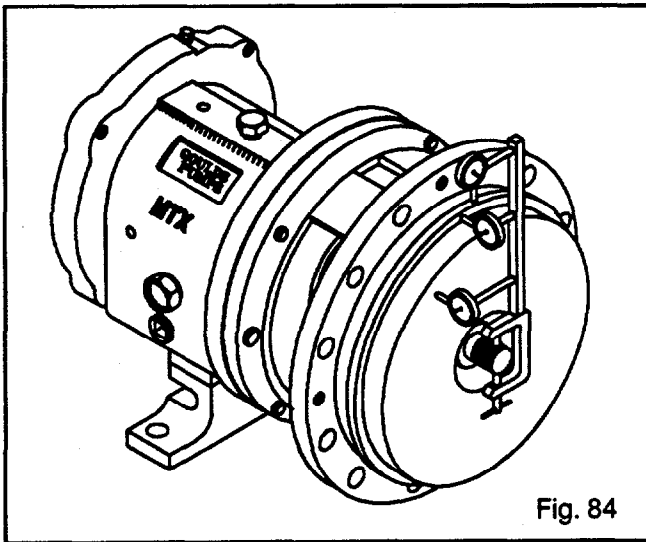

Fig. 84

3. Install shaft sleeve (126) if used (Fig. 85).

NOTE: Make sure sleeve is fully seated.

WARNING

Wear a heavy set of work gloves when handling impeller (101) as sharp edges may cause physical injury.

4. Install impeller (101) with O-ring (412A).

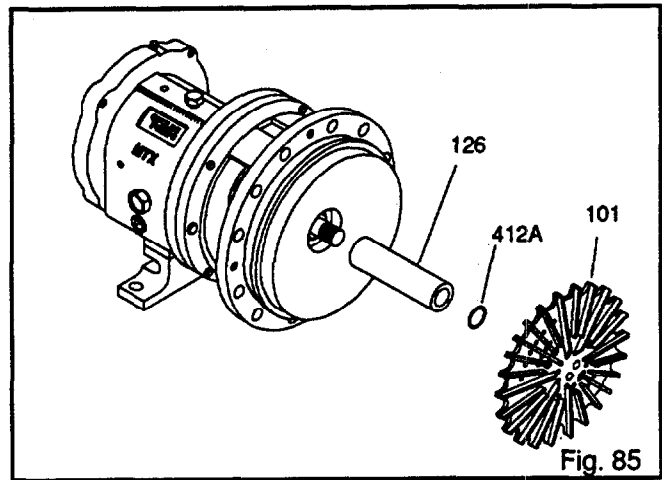

Fig. 85

5. Put shaft wrench and coupling key on shaft. When impeller (101) makes firm contact with sleeve (126), raise shaft wrench (counterclockwise, viewed from impeller end of shaft) off bench and slam it down (clockwise, viewed from impeller end of shaft). A few sharp raps will tighten impeller (101) properly (Fig. 86).

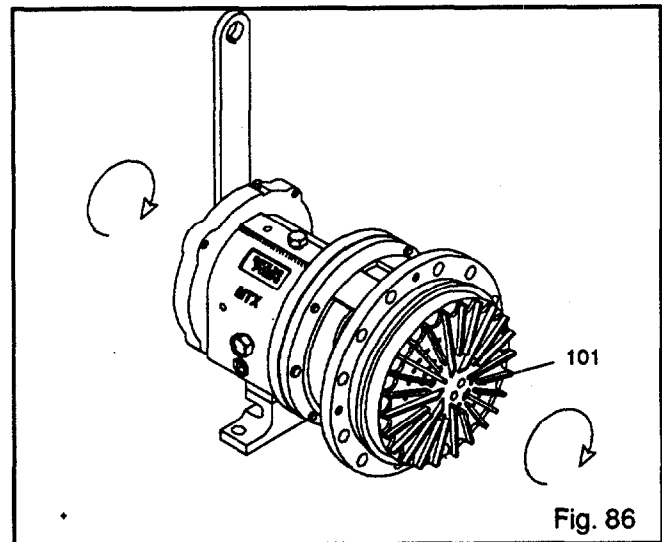
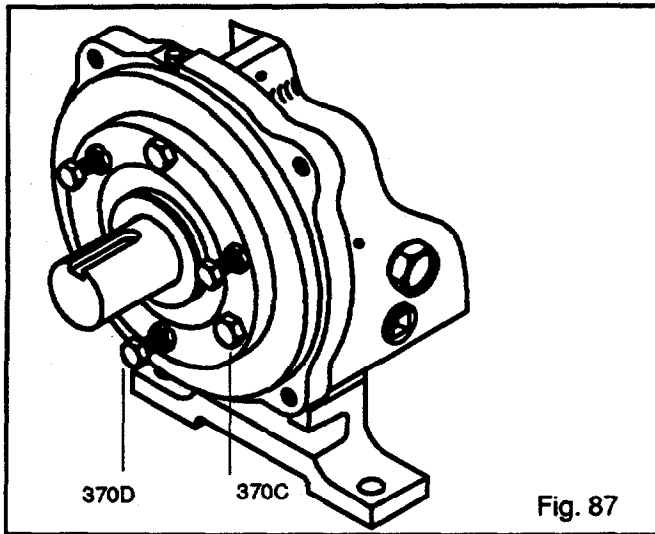

Fig. 86

6. Loosen clamp bolts (370C), and jacking bolts (370D). Measure gap between impeller (101) and seal chamber/stuffing box cover (184). When 0.030 in. (.76 mm) (9/16" for 4" pump) clearance is reached, tighten clamp bolts (370C), jacking bolts (370D), and locking nuts (423) (Fig. 87).

NOTE: This approximates the impeller position when set at 0.015 in. (.38 mm) from casing. Final impeller adjustment must be made after installation into casing.



7. Check impeller (101) runout. Check vane tip to vane tip. If total indicator reading is greater than 0.005 in. (.13 mm), determine cause and correct before proceeding (Fig. 88).

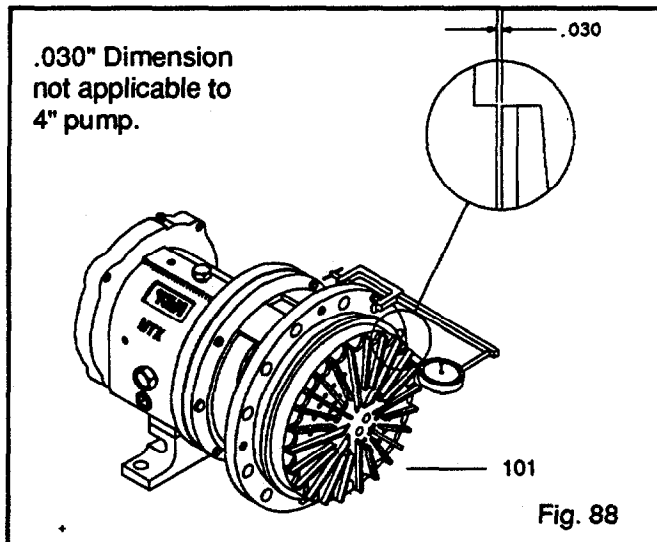

8. Blue the shaft sleeve (126) or shaft (122) if no sleeve is used. Scribe a mark at gland gasket face of seal chamber/stuffing box cover (184). This will be the datum for installation of mechanical seal (Fig. 89).

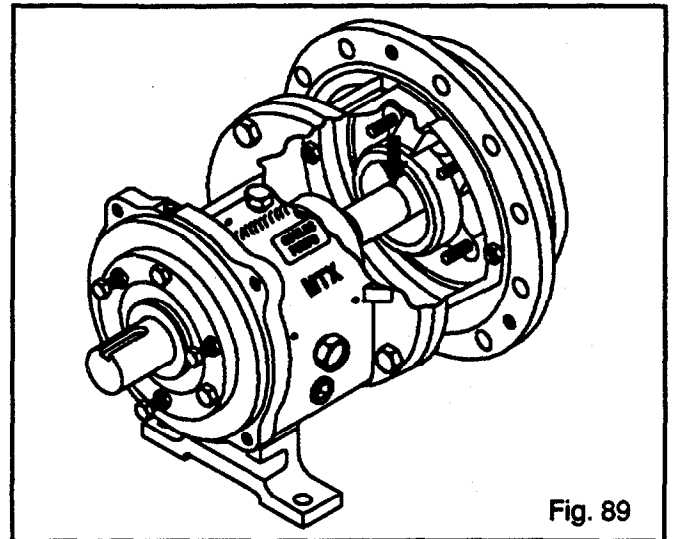

9. Remove the impeller (101), and shaft sleeve (126) if used.

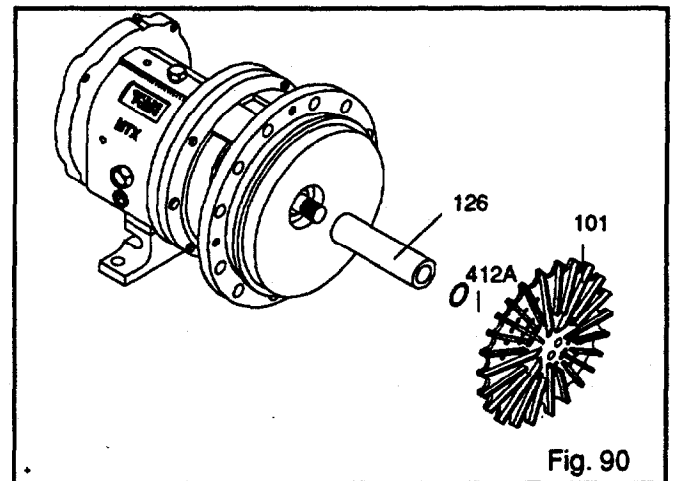

10. Remove seal chamber cover (184).

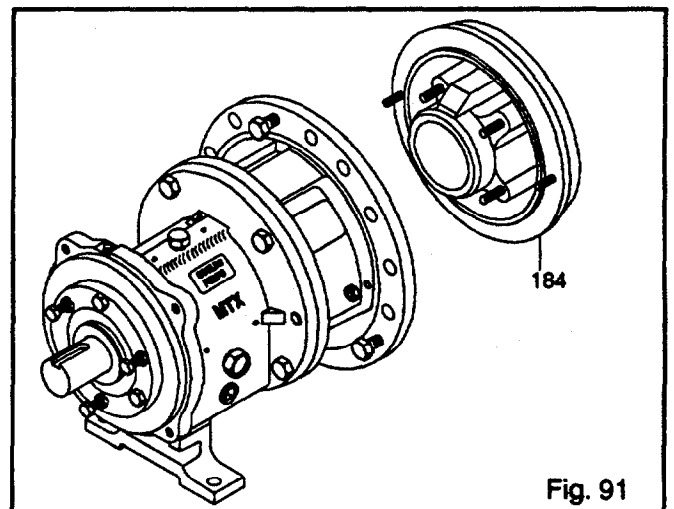

11. Install stationary seat into gland (107) per seal manufacturer's instructions.
12. Slide gland (107) with stationary seat over shaft, up to adapter face.
13. Install mechanical seal on shaft (122) or shaft sleeve (126) per seal manufacturer's instructions. Install shaft sleeve (126) if used (with seal).

NOTE: Anti-galling compound can be applied to the sleeve bore to aid in disassembly.

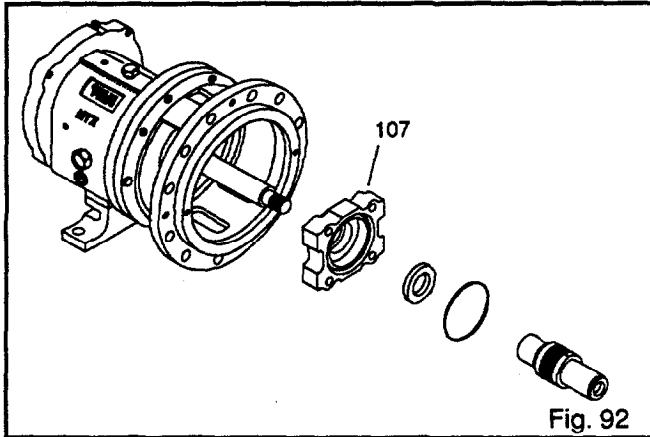

Fig. 92

14. Install seal chamber cover (184) with nuts (370H).

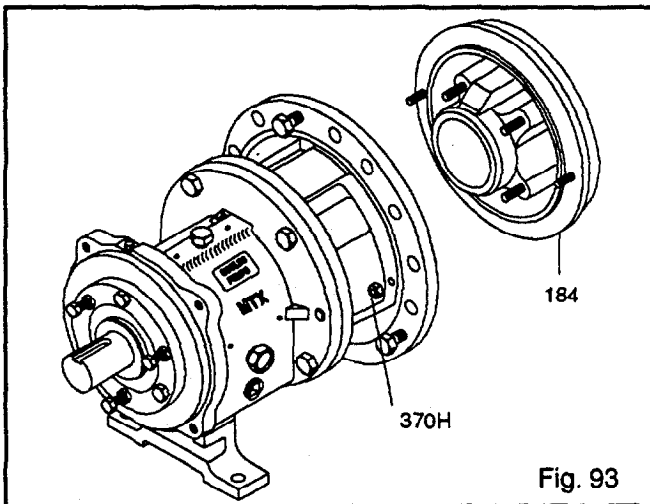

Fig. 93

WARNING

Wear a heavy set of work gloves when handling impeller (101) as sharp edges may cause physical injury.

15. Install impeller (101) with new O-ring (412A). Put shaft wrench and coupling key on shaft. When impeller (101) makes firm contact with sleeve (126), raise shaft wrench (counterclockwise when viewed from impeller end of shaft) off bench and slam it down (clockwise when viewed from impeller end of shaft). A few sharp raps will tighten impeller (101) properly.

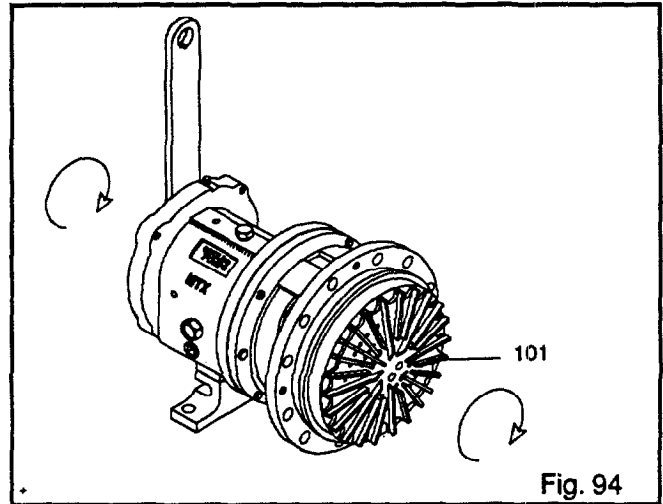

Fig. 94

16. Install gland (107) with nuts (355).

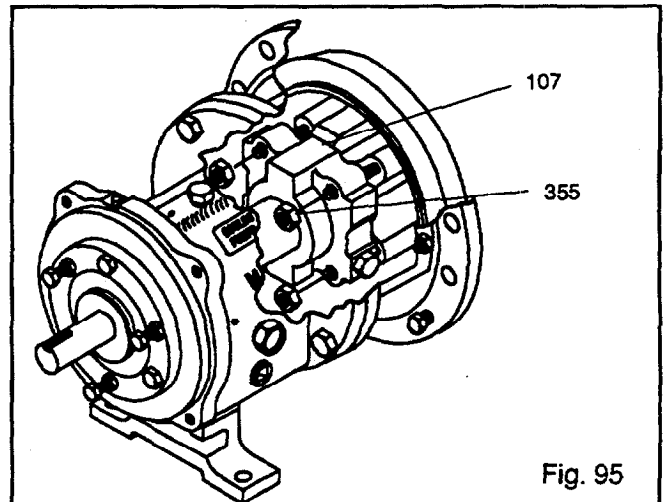
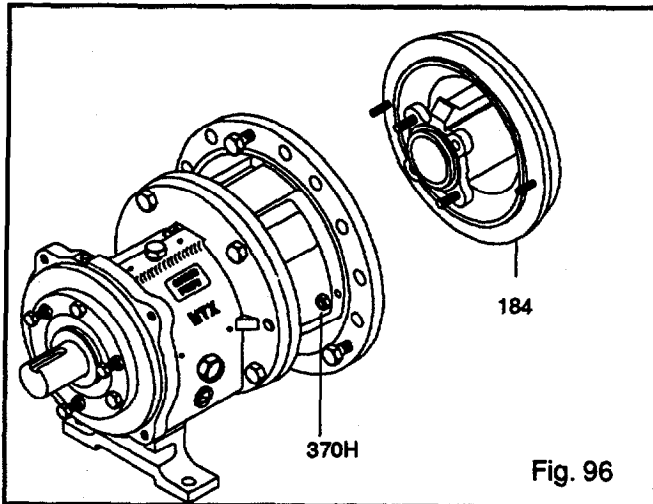

Fig. 95

PUMPS WITH PACKING

1. Install stuffing box cover (184) with nuts (370H).



2. Check stuffing box cover run-out. Rotate indicator thru 360 degrees. Total indicator reading greater than 0.005 in. (.13 mm) indicates a problem (Fig. 97).

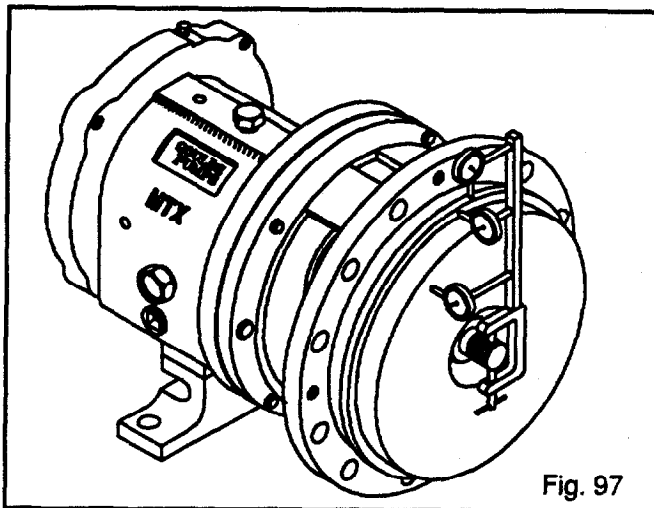

3. Install shaft sleeve (126) (Fig. 98).

NOTE: Anti-galling compound, can be applied to the sleeve bore to aid in disassembly.

NOTE: Make sure sleeve is fully seated.

WARNING

Wear a heavy set of work gloves when handling impeller (101) as sharp edges may cause injury.

4. Install impeller (101) with O-ring (412A). Put shaft wrench and coupling key on shaft. When impeller (101) makes firm contact with sleeve (126), raise shaft wrench (counterclockwise when viewed from impeller end of shaft) off bench and slam it down (clockwise when viewed from impeller end of shaft). A few sharp raps will tighten impeller properly (Fig. 98).

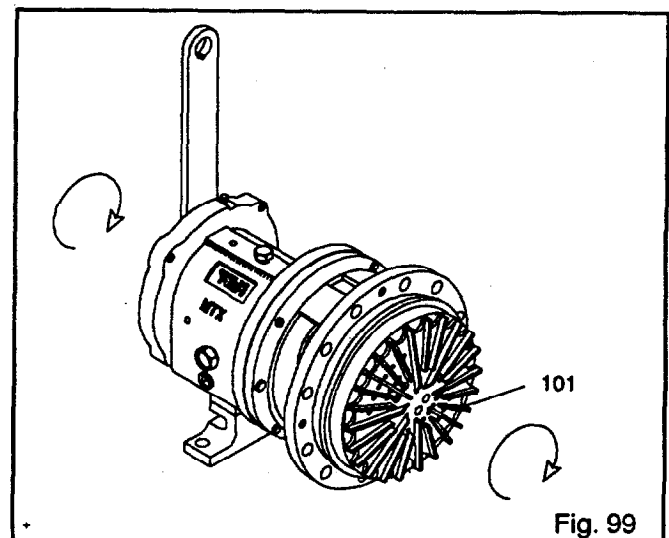
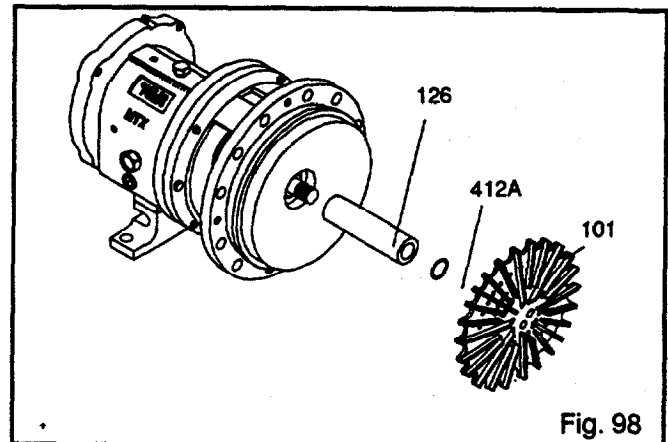

5. Loosen clamp bolts (370C), and jacking bolts (370D) (Fig. 124). Measure gap between impeller (101) and seal chamber/stuffing box cover (184). When 0.030 in. (.76 mm) clearance (9/16" for 4" pump) is reached, tighten clamp bolts (370C), jacking bolts (370D), and locking nuts (423) (Fig. 100).

NOTE: This approximates the impeller position when set at 0.015 in. (.38 mm) from casing.

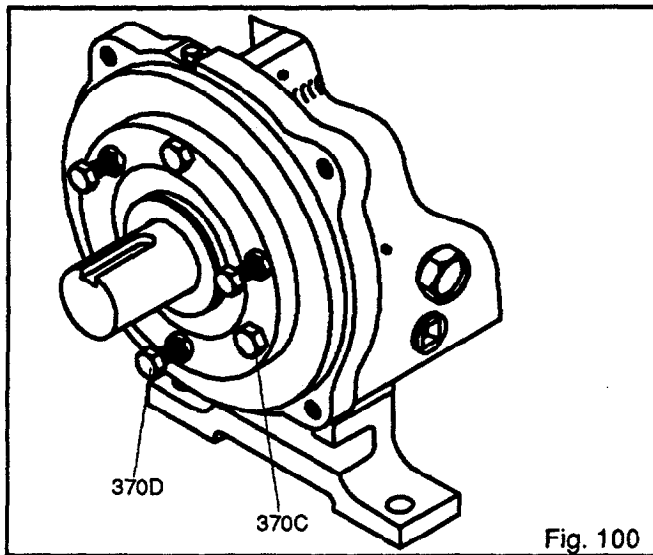

Fig. 100

6. Check impeller runout. Check vane tip to vane tip. Total indicator reading greater than 0.005 in. (.13 mm) indicates a problem (Fig. 101).

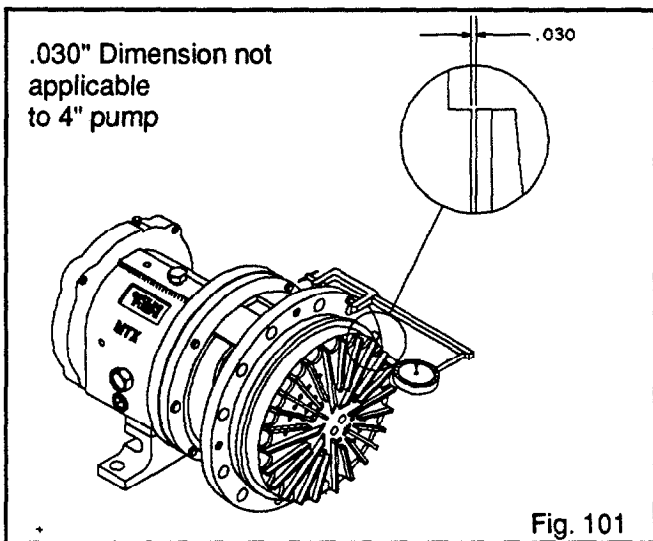

Fig. 101

7. Install packing and gland according to Section 4, Operation.

PUMPS WITH DYNAMIC SEALS

1. Place backplate (444) flat side down on the bench (Fig. 102).
2. Place repeller (262) in backplate (444), sleeve side up.
3. Place teflon gasket (264) on backplate (444), lining up holes.
4. Place stuffing box cover (184) on backplate (444), lining up holes.
5. Install four (4) socket head cap screws (265), tighten securely.

6. Install new sealing element into gland.
7. Install gasket (360Q) and gland (107) on stuffing box cover (184). Install nuts (355).

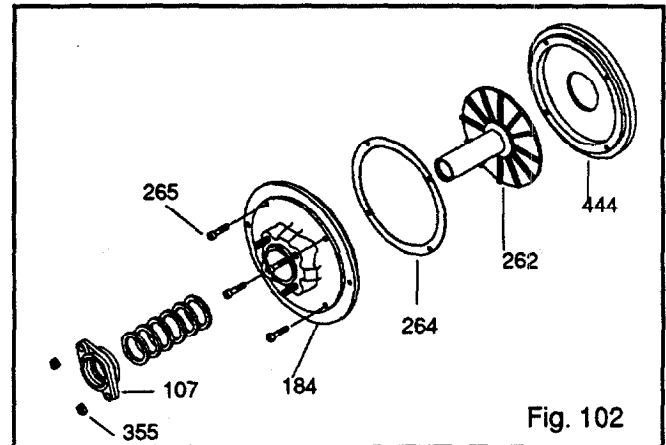

Fig. 102

8. Install dynamic seal assembly. Install nuts (370H) (Fig. 103).

NOTE: Anti-galling compound, can be applied to the sleeve bore to aid in disassembly.

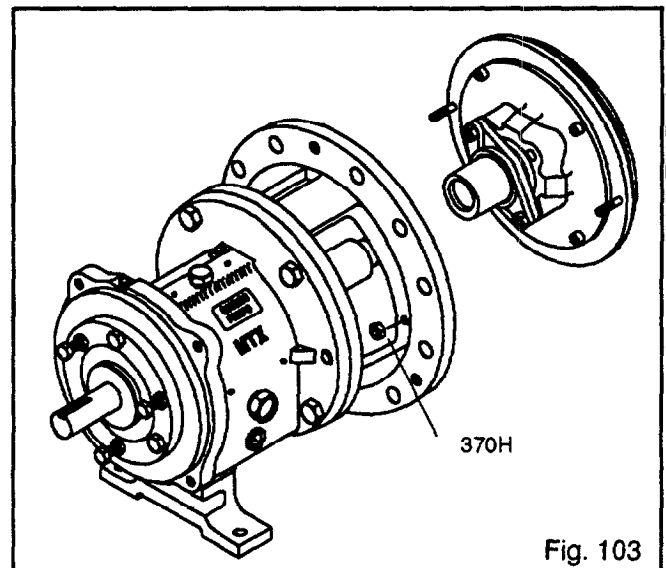

Fig. 103

9. Check stuffing box cover run-out. Rotate indicator thru all 360 degrees. Total indicator reading greater than 0.005 in. indicates a problem (Fig. 104).

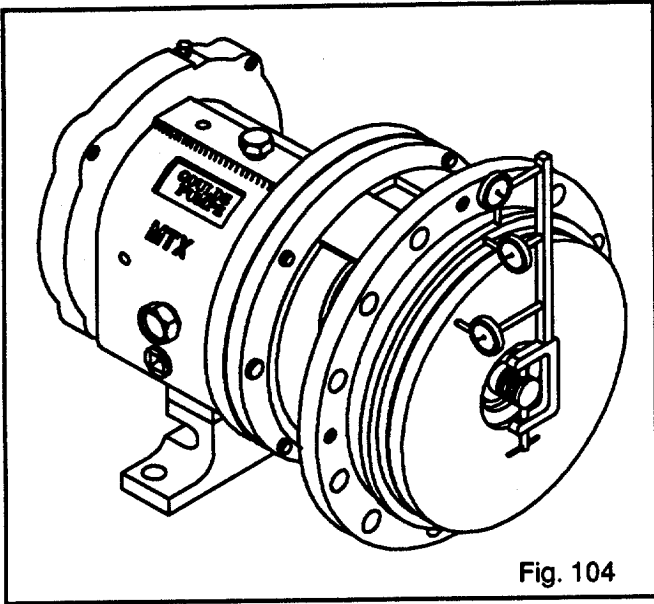

Fig. 104

ALL MODELS STX, MTX, LTX

REINSTALL BACK PULL-OUT ASSEMBLY

WARNING

Back pull-out assembly weighs more than 50 lbs. Do not handle unassisted as physical injury may occur.

1. Clean casing fit and install casing gasket (351) in place on seal chamber/stuffing box cover.
2. Loosen clamping bolts (370C) and jacking bolts (370D) on bearing housing (Fig. 105).

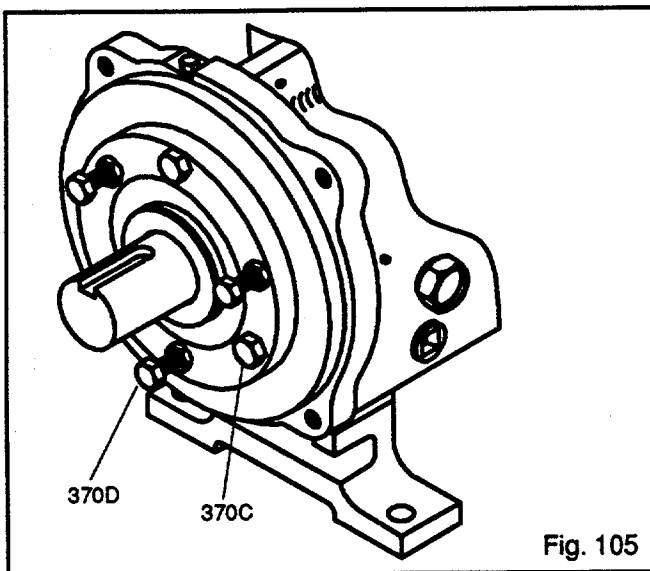

Fig. 105

3. Install back pull-out assembly in casing (Fig. 106).

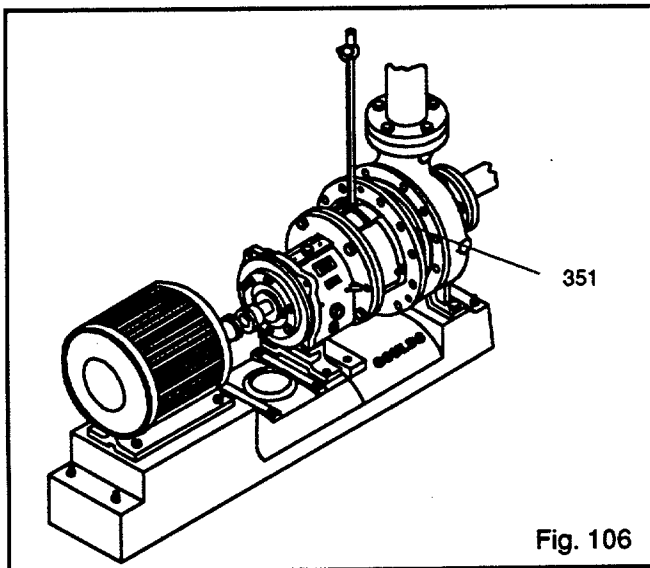

Fig. 106

4. Install casing bolts (370), finger tight. Casing bolts (370) may be coated with anti-galling compound to aid disassembly. Tighten the casing bolts per Table 9 torque values, page 51. Install casing jack screws (418), snug tight (Fig. 107).

CAUTION

Do not overtighten casing jack screws (418).

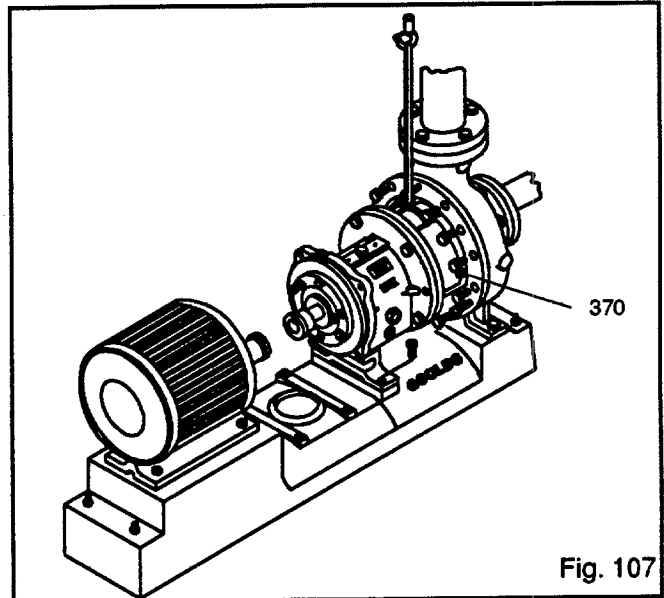

Fig. 107

5. Check total travel of impeller in casing. With new parts acceptable range is 0.030 in. (.76 mm) to 0.065 in. (1.65 mm). If outside this range improper parts or installation, or too much pipe strain is present. Determine cause and correct.
6. Adjust impeller clearance according to procedure outlined in Section 5, Preventive Maintenance.
7. Replace auxiliary piping at this time.
8. Fill pump with proper lubricant. Refer to Section 5, Preventive Maintenance for requirements.

POST ASSEMBLY CHECKS

After completion of these operations check whether it is possible to rotate shaft easily by hand. If all is proper, continue with pump start-up

| Assembly Troubleshooting | |
|---|---|
| Symptom | Cause |
| Excessive shaft end play. | Bearing internal clearance too great. Replace bearings with correct type. Snap ring loose in bearing housing groove. Reseat. |
| Excessive shaft/sleeve runout. | Sleeve worn. Replace Shaft bent. Replace. |
| Excessive bearing frame flange runout. | Shaft bent. Replace. Bearing frame flange distorted. Replace. |
| Excessive frame adapter runout. | Corrosion. Replace. Adapter-to-frame gasket not seated properly. Reseat. |
| Excessive seal chamber/stuffing box cover runout. | Seal chamber/stuffing box cover not properly seated in frame adapter. Corrosion or wear. Replace. |
| Excessive impeller vane tip runout. | Bent vane(s). Replace impeller. |

MATERIAL CROSS REFERENCE CHART

| Goulds Pumps Material Code | Material | ASTM | DIN | ISO | JIS |
|----------------------------|--------------|-----------------|--------|-----|---------------|
| 1001 | Cast Iron | A48 CLASS 20 | | | |
| 1012 | Ductile Iron | A395 Gr60-40-18 | | | |
| 1013 | Ductile Iron | A536 Gr60-42-10 | | | |
| 1119 | Monel | A494 GrM-35-1 | | | |
| 1203 | 316SS | A744 CF-8M | 1.4408 | | G5121 (SC514) |
| 1204 | Alloy 20 | A744CN-7M | 1.4500 | | |
| 1209 | 317SS | A744CG-8M | 1.4448 | | |
| 1215 | Hastelloy C | A494 CW-6M | | | |
| 1216 | CD4MCu | A744CD4MCU | 9.4460 | | |
| 1217 | Hastelloy B | A494 N-7M | | | |
| 1220 | Titanium | B367 GrC-3 | | | |
| 1601 | Nickel | A494 GrCZ100 | | | |
| 2150 | Monel | B164 UNS N04400 | | | |
| 2155 | Nickel | B160 UNS N02200 | | | |
| 2156 | Titanium | B348 Gr2 | | | |
| 2210 | Carbon Steel | A108Gr1211 | | | |
| 2228 | 304SS | A276 Type 304 | | | |
| 2229 | 316SS | A276 Type 316 | | | |
| 2230 | Carpenter 20 | B473 (N08020) | | | |
| 2232 | 317SS | A276 | | | |
| 2237 | 4150 Steel | A322Gr4150 | | | |
| 2238 | 4140 Steel | A434Gr4140 | | | |
| 2247 | Alloy B-2 | B335 (N10665) | | | |
| 2248 | Alloy C-276 | B574 (N10276) | | | |

FASTENERS/PLUGS

| Goulds Pumps Material Code | Material | ASTM |
|----------------------------|---------------------|-----------|
| 2210 | Carbon Steel | A307Gr.B. |
| 2228 | Stainless Steel | F593Gr1 |
| 2229 | 316 Stainless Steel | F593Gr2 |

STX

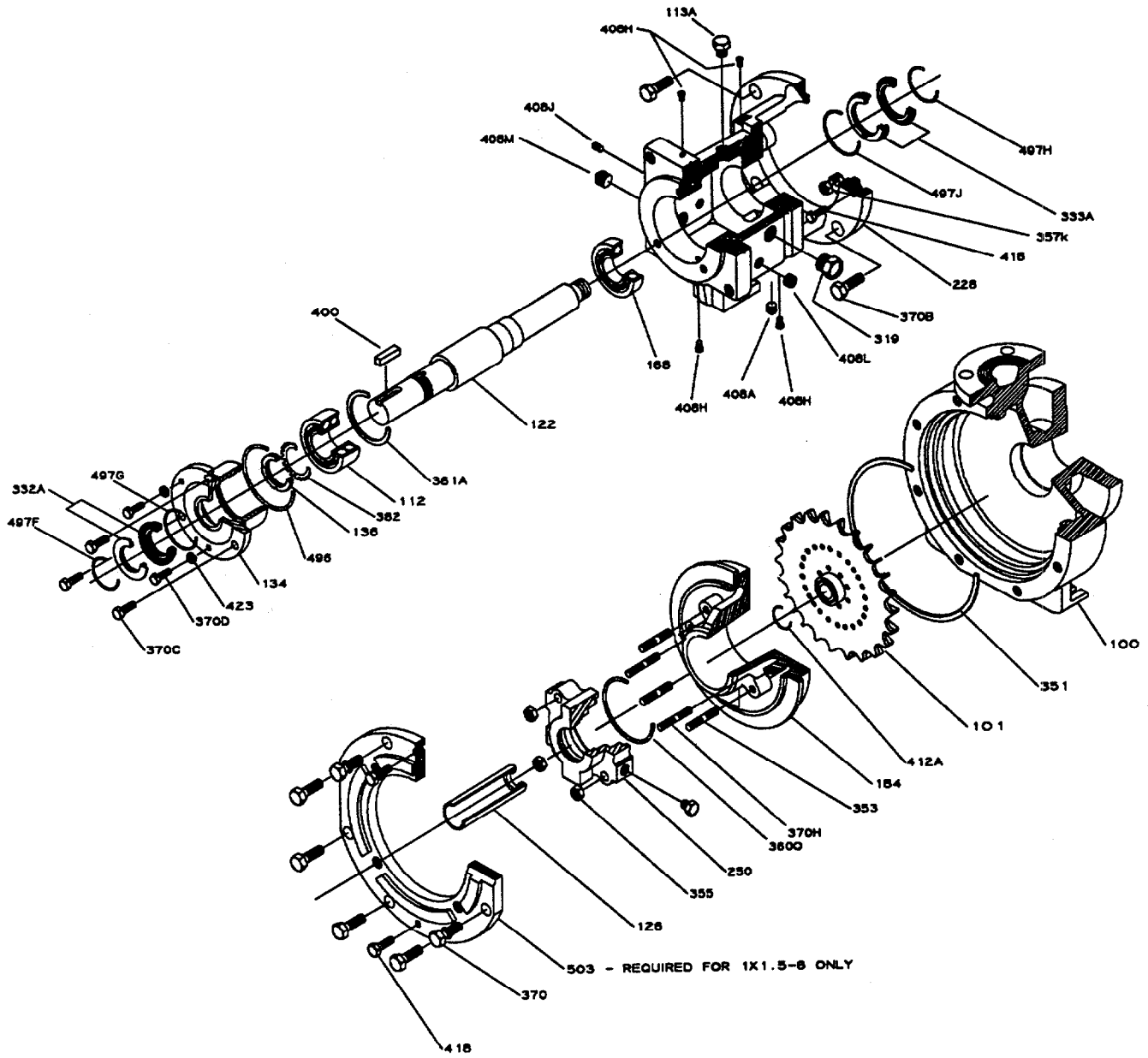

MTX

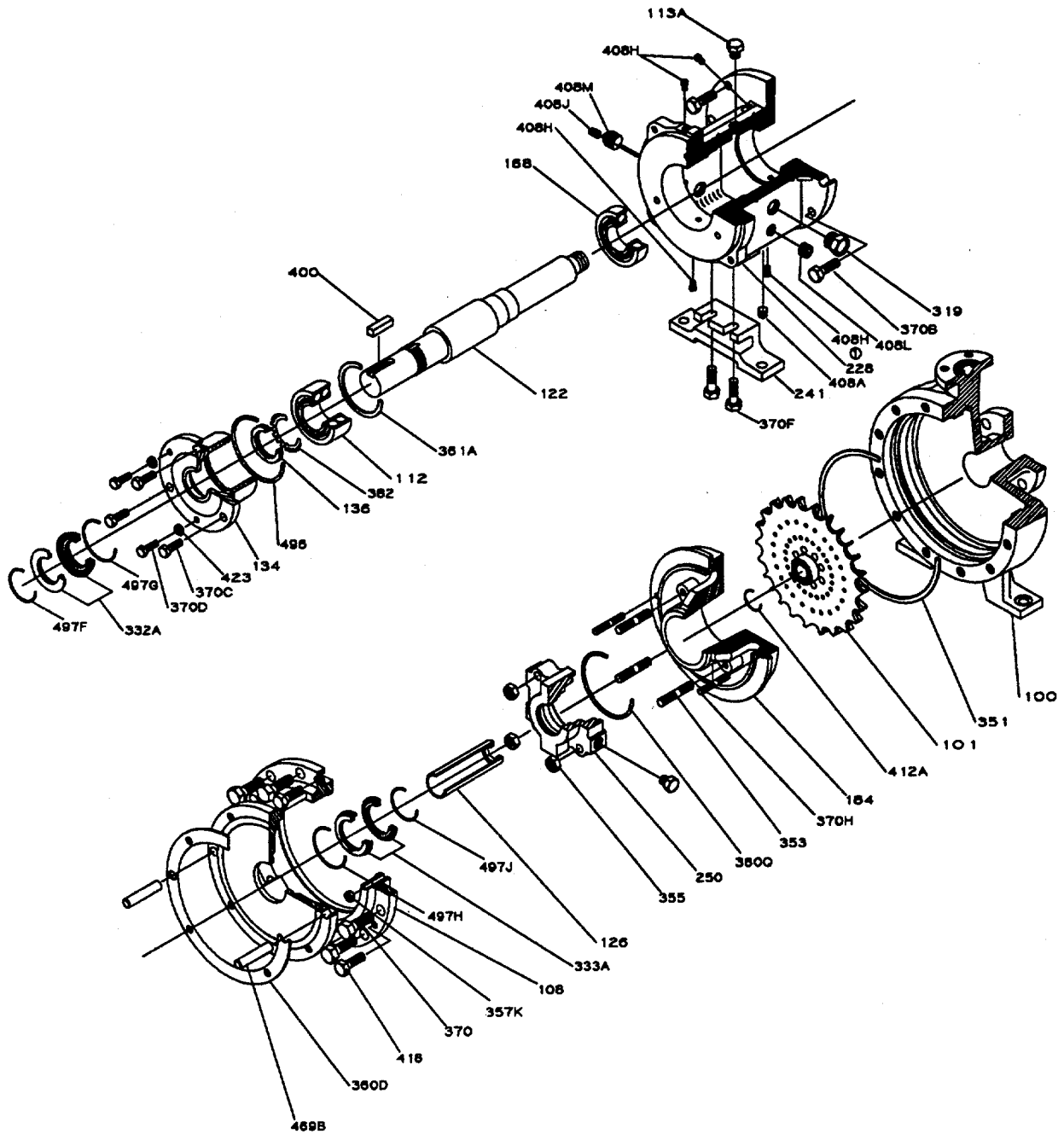

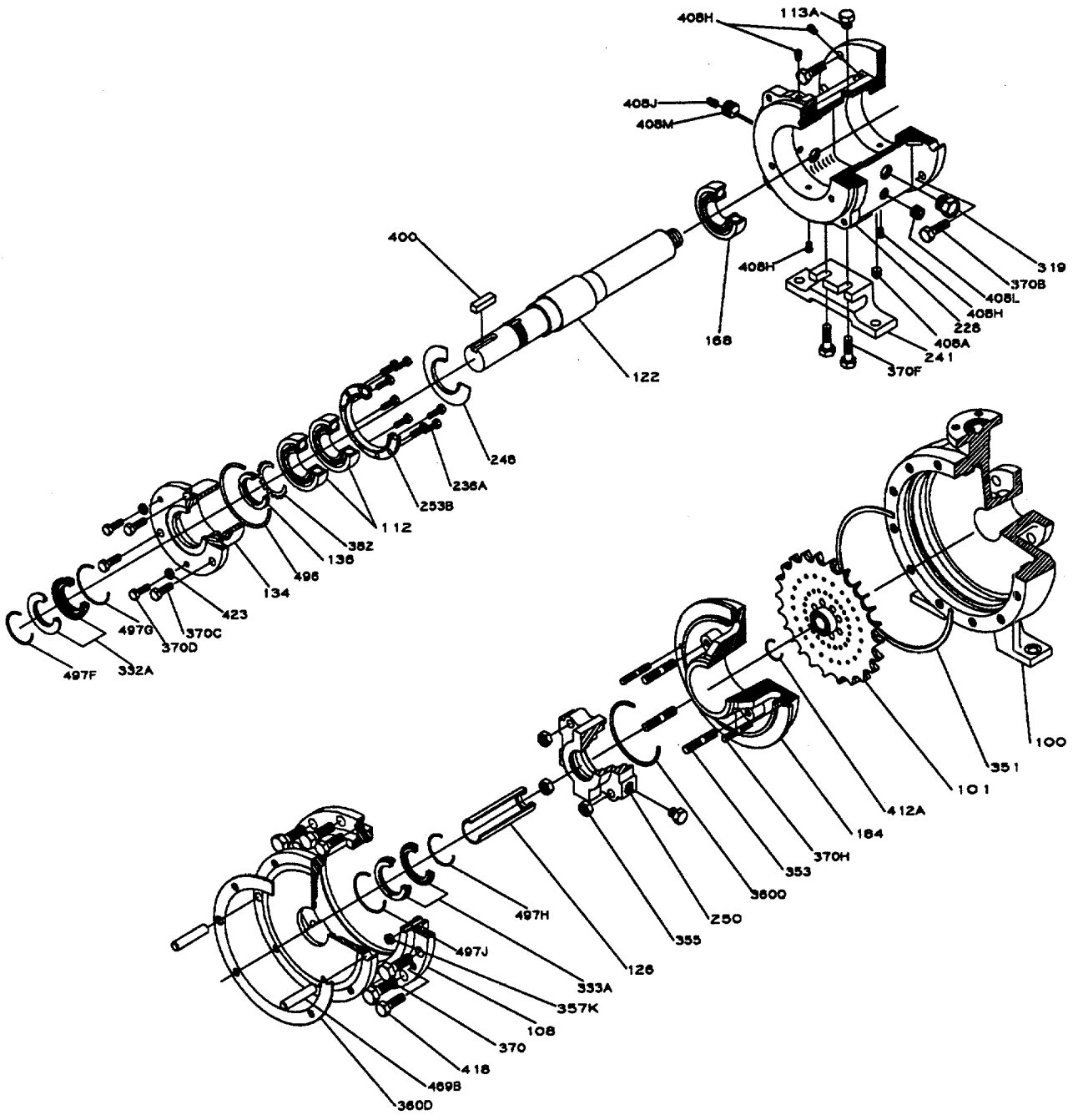

SPARE PARTS

| | |
|--|-----------|
| Recommended Spare Parts | 71 |
| Interchangeability | 72 |
| How to order parts | 73 |
| Appendix I | 75 |
| Appendix II | 77 |

When ordering spare parts, always state Goulds Serial No., and indicate part name and item number from relevant sectional drawing. It is an imperative for service reliability to have a sufficient stock of readily available spares.

RECOMMENDED SPARE PARTS

Suggested Spare Parts

- Impeller (101)
- Shaft (122A)
- Shaft Sleeve (126)
- Outboard Bearing (112A)
- Inboard Bearing (168A)
- Casing Gasket (351)
- Frame-to-Adapter Gasket (360D)
- Bearing Housing Retaining Ring (361A)
- Bearing Lockwasher (382)
- Bearing Locknut (136)
- Impeller O-Ring (412A)
- Bearing Housing O-Ring (496)
- Outboard Labyrinth Seal Rotary O-Ring (497F)
- Outboard Labyrinth Seal Stationary O-Ring (497G)
- Inboard Labyrinth Seal Rotary O-Ring (497H)
- Inboard Labyrinth Seal Stationary O-Ring (497J)
- Lantern Ring Half (105) (Packed Stuffing Box)
- Stuffing Box Packing (106) (Packed Stuffing Box)
- Packing Gland (107) (Packed Stuffing Box)

INTERCHANGEABILITY

LF 3196 MODULAR/DIMENSIONAL INTERCHANGEABILITY

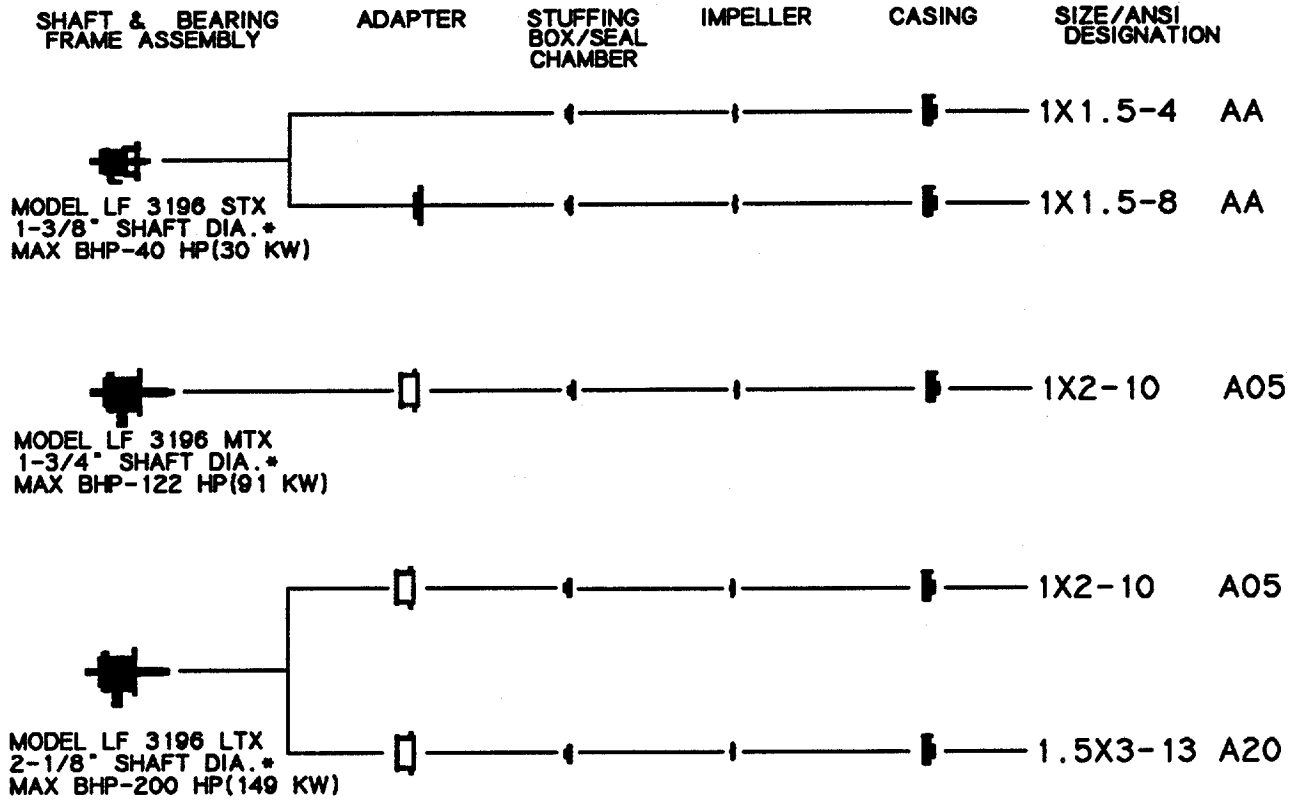

* DIMENSION SHOWN IS SLEEVE OR SOLID SHAFT DIAMETER.

HOW TO ORDER

**When ordering parts call
1-800-446-8537
or your local Goulds Representative**

EMERGENCY SERVICE

**Emergency parts service is available
24 hours/day, 365 days/year . . .
Call 1-800-446-8537**

APPENDIX I

Lubrication Conversion

| | Pumpage Temperature below 350°F (177°C) | Pumpage Temperature above 350°F (177°C) |
|------------------|--|--|
| NLGI Consistency | 2 | 3 |
| Mobil | Mobilux EP2 | |
| Exxon | Unirex N2 | Unirex N3 |
| Sunoco | Multipurpose EP | |
| SKF | LGMT 2 | LGMT 3 |

Pumpage temperatures above 350°F (177°C) should be lubricated by a high temperature grease. Mineral oil greases should have oxidation stabilizers and a consistency of NLGI 3.

NOTE: If it is necessary to change grease type or consistency, the bearings must be removed and the old grease removed.

CAUTION

Never mix greases of different consistency (NLGI 1 or 3 with NLGI 2) or different thickener soaps (sodium or calcium with lithium). The consistency usually becomes softer and will not provide adequate lubrication to the bearings.

FRAME LUBRICATION CONVERSION

CONVERSION FROM FLOOD OIL TO PURE OIL MIST

There are several ways to apply oil mist. Goulds has designed X-Series Power Ends to accept a variety of oil mist configurations. The following instructions are written for two popular systems in use.

NOTE: Make sure that pipe threads are clean and apply thread sealant to plugs & fittings.

A.

1. Attach oil mist inlet to 1/4" NPT connection at top, outboard end of frame (plugged with 408H allen head plug), and top, center of frame (plugged with 113A hex head plug).
2. Attach drain at bottom center of frame 3/8" NPT hole (plugged with 408A magnetic drain plug).
3. Follow oil mist generator manufacturer's instructions for oil mist volume adjustment, and operation.

B.

1. Attach oil mist inlet connection to 1/4" NPT connections at outboard and inboard ends of Power End.
2. Attach vent connection at 1/2" NPT hole located in top center of Power End.
3. Attach drain connection at 3/8" NPT hole located at bottom center of Power End (plugged with 408A magnetic drain plug).
4. Follow oil mist generator manufacturer's instructions for oil mist volume adjustment and operation.

8

CAUTION

Oil mist falls under Title III of the Clean Air Act and must be controlled or the user will be subject to penalty.

CONVERSION FROM FLOOD OIL TO REGREASEABLE

NOTE: Make sure that pipe threads are clean and apply thread sealant to plugs and fittings.

1. Plug inboard oil return in bearing frame.

STX: Use epoxy, keep drilled hole clear.

MTX, LTX:

1. Use set screw, install from adapter side, bottom in hole.
2. Plug outboard oil in return slot in bearing housing, keep through holes clear.
3. Replace both bearings with single shield type. Refer to Assembly Section for installation guidelines.
4. Install grease fittings at top, inboard and top, outboard 1/4" NPT connections in bearing frame (plugged with 408H Allen head plug).
5. Replace sight glass with 1 in. NPT plug.
6. Remove 2 (408H) Allen head plugs from bottom side of frame prior to greasing bearings. Reinstall plugs after bearings have been greased.

APPENDIX II

INSTALLATION INSTRUCTIONS FOR GOULDS ANSI B15.1 COUPLING GUARDS

WARNING

Before assembly or disassembly of the coupling guard is performed the motor must be de-energized, the motor controller/starter put in a locked-out position and a caution tag placed at the starter indicating the disconnect. Replace coupling guard before resuming normal operation of the pump. Goulds Pumps, Inc. assumes no liability for avoiding this practice.

NOTE: Coupling adjustments should be completed before proceeding with coupling guard assembly.

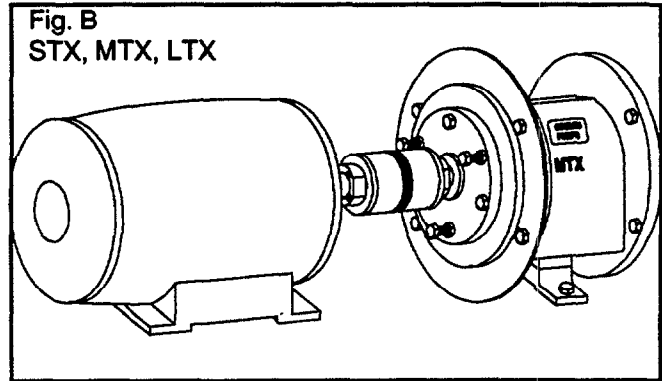
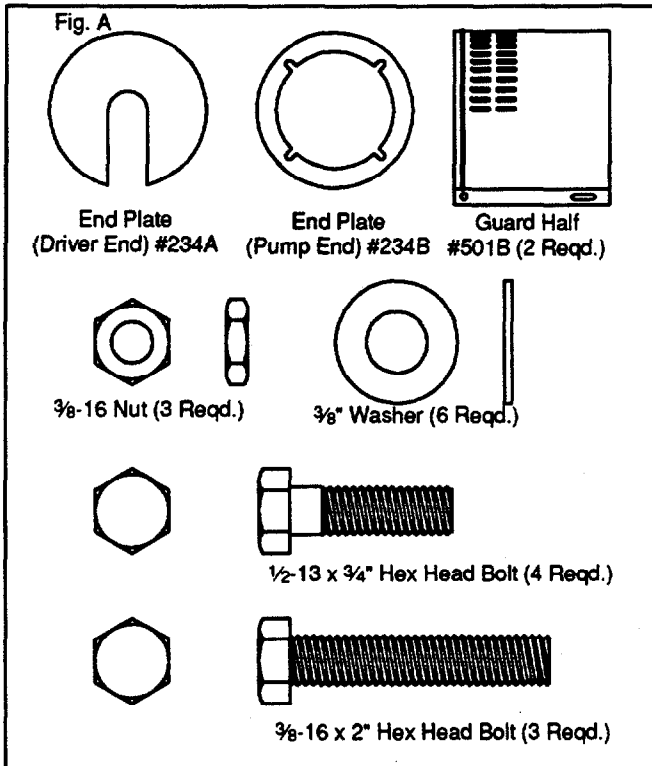

2. Spread bottom of coupling guard half (pump end) slightly and place over pump end plate as shown in Fig. C. The annual groove in the guard half is located around the end plate. See detail drawing, Fig. E.

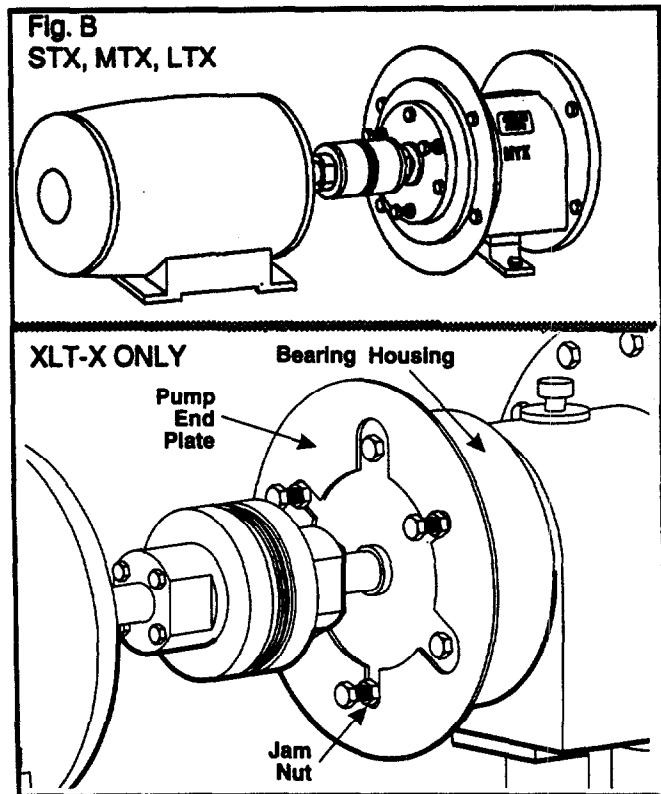

Simplicity of design allows complete assembly of the coupling guard, including the end plate (pump end), in about fifteen minutes. If the end plate is already in place, assembly can be accomplished in about five minutes.

ASSEMBLY

NOTE: If end plate (pump end) is already installed, make any necessary coupling adjustments and then proceed to Step 2.

STX, MTX, LTX - Align end plate (pump end) to the Bearing Frame. (No impeller adjustment required)

- After the coupling guard half (pump end) is located around the end plate, secure it with a bolt, nut and two (2) washers through the round hole at the front end of the guard half as shown in Fig. D. Tighten securely. See detail drawing, Fig. E.

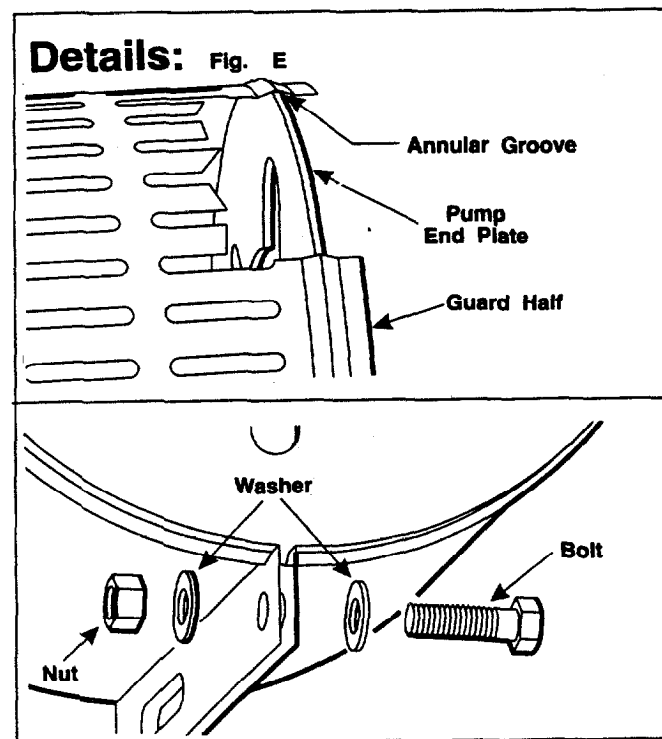
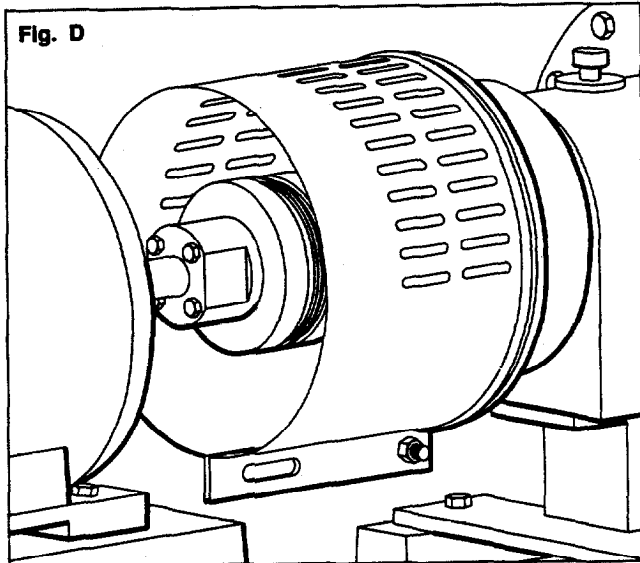

- Spread bottom of coupling guard half (driver end) slightly and place over coupling guard half (pump end) so that annular groove in coupling guard half (driver end) faces the motor as shown in Fig. F.

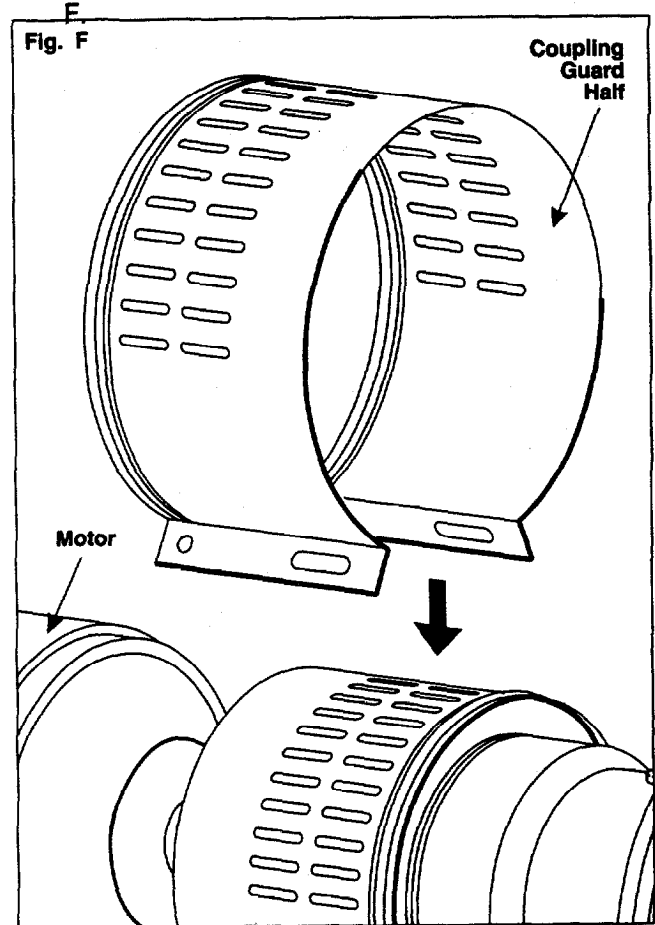

- Place end plate (driver end) over motor shaft as shown in Fig. G. Locate the end plate in the annular groove at the rear of the coupling guard half (driver end) and secure with a bolt, nut, and two (2) washers through the round hole at the rear of the guard half. Finger tighten only.

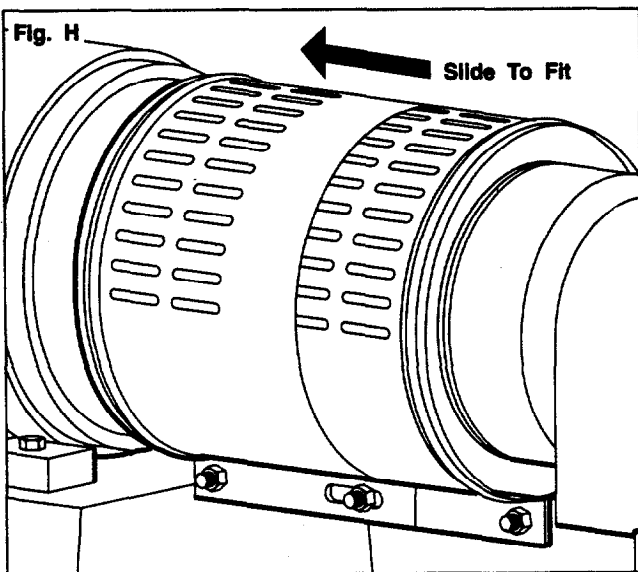
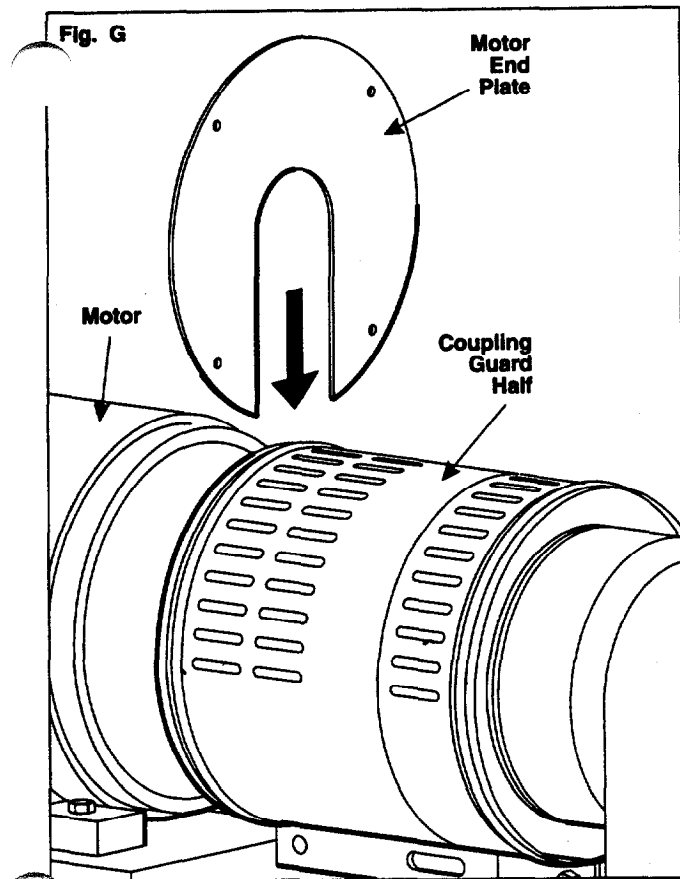

6. Adjust length of coupling guard to completely cover shafts and coupling as shown in Fig. H by sliding coupling guard half (driver end) towards motor. After adjusting guard length, secure with bolt, nut and two (2) washers through the slotted holes at the center of the guard and tighten. Check all nuts on the guard assembly for tightness.

WARNING

Before assembly or disassembly of the coupling guard is performed the motor must be de-energized, the motor controller/starter put in a locked-out position and a caution tag placed at the starter indicating the disconnect. Replace coupling guard before resuming normal operation of the pump. Goulds Pumps, Inc. assumes no liability for avoiding this practice.

DISASSEMBLY

The coupling guard must be removed for certain maintenance and adjustments to the pump, such as adjustment of the coupling, impeller clearance adjustment, etc. The coupling guard should be replaced after maintenance is completed.

DO NOT resume normal pump operation with the coupling guard removed.

NOTE: Refer to illustrations for assembly in reverse order.

1. Remove nut, bolt, and washers from center slotted hole in the coupling guard. Slide motor end coupling guard half towards pump. Fig. H.
2. Remove nut, bolt, and washers from coupling guard half (driver end), and remove end plate. Fig. G.
3. Spread bottom of coupling guard half slightly and lift off. Fig. F.
4. Remove remaining nut, bolt, and washers from coupling guard half (pump end). Spread bottom of coupling guard half slightly and lift off. Fig. C.

This completes disassembly of the coupling guard.

NOTE: It is not necessary to remove the end plate (pump end) from the pump bearing housing. The bearing housing tap bolts are accessible without removing the end plate in case maintenance of internal pump parts is necessary. Before removing the pump bearing housing, refer to the Goulds operations and maintenance manual for your particular pump.

 **GOULDS PUMPS, INC.**
INDUSTRIAL PRODUCTS GROUP
Seneca Falls, New York 13148

Form No. EPD-180 10/92



Printed in U.S.A.

APPENDIX H

SECTION 7

| CAMP LEJEUNE WELL PUMPS | | |
|------------------------------------|-------------------|---------------------|
| Well Location | Pump Model | Manufacturer |
| DMW - 1 | 135S150-9 w/15 hp | Grundfos |
| DRW - 1 | 180S50-5 | Grundfos |
| DRW - 2 | 40S50-12 w/5 hp | Grundfos |
| DRW - 3 | 40S50-12 w/5 hp | Grundfos |
| SRW - 1 | 5E8 w/ 1/3 hp | Grundfos |
| SRW - 2 | 5E8 w/ 1/3 hp | Grundfos |
| SRW - 3 | 5E8 w/ 1/3 hp | Grundfos |
| SRW - 4 | 5E8 w/ 1/3 hp | Grundfos |
| SRW - 5 | 5E8 w/ 1/3 hp | Grundfos |
| SRW - 6 | 5E8 w/ 1/3 hp | Grundfos |

Well Pump Vendor: Driller Services Inc.
Contact: Terry Younf
Phone: (800) 334-2308

Installation and Operating Instructions

Grundfos Redi-Flo4
Stainless Steel Submersible Pumps
for Environmental
Applications

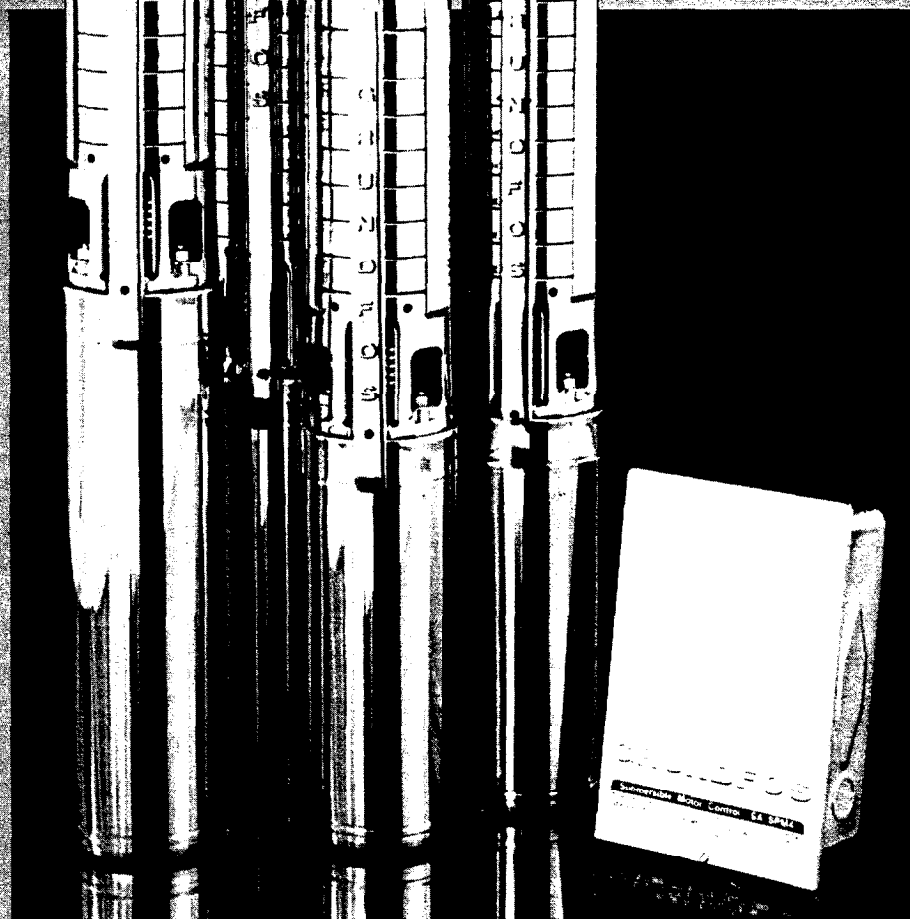

1. Shipment
Inspection
Page 1

2. Pre-Installation
Checklist
Page 1

3. Wire Cable
Type
Page 2

4. Installation
Page 2

5. Electrical
Page 3

6. Start-Up
Page 4

7. Troubleshooting
Page 4

***Please leave these instructions
with the pump***

Installation and Operating Instructions

TABLE OF CONTENTS

| | | |
|--|-------|--------|
| SECTION 1 | | |
| Shipment Inspection | | Page 1 |
| SECTION 2 | | |
| Pre-Installation Checklist | | Page 1 |
| SECTION 3 | | |
| Wire Cable Type | | Page 2 |
| SECTION 4 | | |
| Installation | | Page 2 |
| SECTION 5 | | |
| Electrical | | Page 3 |
| Engine Driven Generators | | 3 |
| Control Box, Single-Phase Motors | | 3 |
| High Voltage Surge Arresters | | 3 |
| Control Box and Surge Arrester Grounding | | 3 |
| Wiring Checks | | 3 |
| SECTION 6 | | |
| Start-Up | | Page 4 |
| Operation | | Page 4 |
| SECTION 7 | | |
| Troubleshooting | | Page 4 |
| Preliminary Tests | | 5 |
| Troubleshooting Chart | | 6 |
| Table A | | 7 |
| Table B | | 7 |
| Table C | | 8 |
| Table D | | 9 |

Installation and Operating Instructions

GRUNDFOS **Redi-Flo4**

Your Grundfos Redi-Flo4 Environmental Pump is of the utmost quality. Combined with proper installation, your Grundfos pump will give you many years of reliable service.

To ensure the proper installation of the pump, carefully read the complete manual before attempting to install the pump.



SECTION 1.

Shipment Inspection

Examine the components carefully to make sure no damage has occurred to the pump-end, motor, cable or control box during shipment.

This Grundfos Redi-Flo4 Environmental Pump should remain in its shipping carton until it is ready to be installed. The carton is specially designed to protect it from damage. During unpacking and prior to installation, **make sure that the pump is not contaminated, dropped or mishandled.**

The motor is equipped with an electrical cable. **Under no circumstance should the cable be used to support the weight of the pump.**

You will find a loose data plate wired to the pump. It should be securely mounted at the well or attached to the control box.

SECTION 2.

Pre-Installation Checklist

Before beginning installation, the following checks should be made. They are all critical for the proper installation of this submersible pump.

A. CONDITION OF THE WELL

If the pump is to be installed in a new well, the well should be fully developed and bailed or blown free of cuttings and sand. Dispose of discharged materials in accordance with the specific job site requirements. The stainless steel construction of the Redi-Flo4 Environmental Pump makes it resistant to abrasion; however, no pump, made of any material, can forever withstand the destructive wear that occurs when constantly pumping sandy groundwater.

Determine the maximum depth of the well, and the drawdown level at the pump's maximum capacity. Pump selection and setting depth should be based on this data.

The inside diameter of the well casing should be checked to ensure that it is not smaller than the size of the pump and motor.

B. CONDITION OF THE WATER

Redi-Flo4 pumps are designed for pumping cold groundwater that is free of air or gases. Decreased pump performance and life expectancy can occur if the groundwater is not cold or contains air or gases.

C. INSTALLATION DEPTH

Pumping sand or well sediment can occur when the pump motor is installed lower than the top of the well screen or within five feet of the well bottom. This can reduce the performance and life expectancy of the pump and should be avoided.

If the pump is to be installed in a lake, containment pond, tank or larger diameter well, the water velocity passing over the motor must be sufficient to ensure proper motor cooling. The minimum recommended water flow rates which ensure proper cooling are listed in Table A.

D. ELECTRICAL SUPPLY

The motor voltage, phase and frequency indicated on the motor nameplate should be checked against the actual electrical supply.

SECTION 3.

Wire Cable Type

The type of wire used between the pump and control box should be approved for submersible pump applications. The conductor insulation should have a continuous Teflon® jacket

with no splices and must be suitable for use with submersible pumps.

SECTION 4.

Installation

The riser pipe or hose should be properly sized and selected based on estimated flow rates and friction-loss factors.

A back-up wrench should be used when attaching a riser pipe or metallic nipple to the pump. The pump should only be gripped by the flats on the top of the discharge chamber. **The body of the pump, cable guard or motor should not be gripped under any circumstance.**

If steel riser pipe is used:

An approved pipe thread compound should be used on all joints. Make sure the joints are adequately tightened in order to resist the tendency of the motor to loosen the joints when stopping and starting.

When tightened, the first section of the riser pipe must not come in contact with the check valve retainer in the discharge chamber of the pump.

After the first section of the riser pipe has been attached to the pump, the lifting cable or elevator should be clamped to the pipe. **Do not clamp the pump.** When raising the pump and riser section, be careful not to place bending stress on the pump by picking it up by the pump-end only.

Make sure that the electrical cables are not cut or damaged in any way when the pump is being lowered in the well.

The drop cable should be secured to the riser pipe at frequent intervals using an approved clip or tape to prevent sagging, looping and possible cable damage.

If plastic or flexible riser pipe is used:

Use the correct compound recommended by the pipe manufacturer or specific job specifications. Besides making sure that joints are securely fastened, the use of a torque arrester is recommended when using these types of pipe.

Do not connect the first plastic or flexible riser section directly to the pump. Always attach a metallic nipple or adapter into the discharge chamber of the pump. When tightened, the threaded end of the nipple or adapter must not come in contact with the check valve retainer in the discharge chamber of the pump.

The drop cable should be secured to the riser pipe at frequent intervals using an approved clip or tape to prevent sagging, looping and possible cable damage.

IMPORTANT- Plastic and flexible pipe tend to stretch under load. This stretching must be taken into account when securing the cable to the riser pipe. Leave enough slack between clips or taped points to allow for this stretching. This tendency for plastic and flexible pipe to stretch will also affect the calculation of the pump setting depth. If the depth setting

is critical, check with the manufacturer of the pipe to determine how to compensate for pipe stretch.

When these types of pipe are used, it is recommended that a safety cable be attached to the pump to lower and raise it. The discharge piece of Redi-Flo4 submersibles is designed to accommodate this cable. (Figure 4)

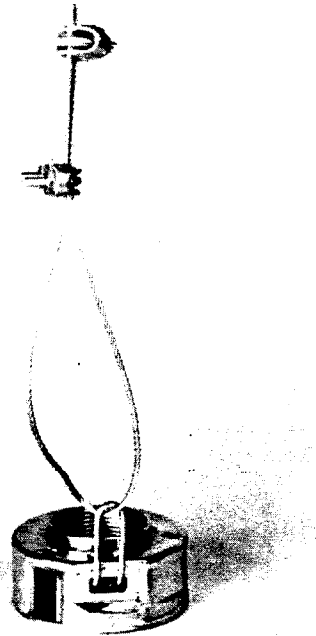

Protect the well from contamination:

While installing the pump, proper care should be used not to introduce foreign objects or contaminants into the well. The well should be finished off above grade to protect against surface water from entering the well, causing contamination.

NOTE: Teflon® is a registered trademark of DuPont.

Electrical

WARNING: To reduce the risk of electric shock during operation of this pump requires the provision of acceptable grounding. If the means of connection to the supply connected box is other than grounded metal conduit, ground the pump back to the service by connecting a copper conductor, at least the size of the circuit supplying the pump, to the grounding screw provided within the wiring compartment.

All electrical work should be performed by a qualified electrician in accordance with the latest edition of the National Electrical Code, local codes and regulations.

Verification of the electrical supply should be made to ensure the voltage, phase and frequency match that of the motor. Motor voltage, phase, frequency and full-load current information can be found on the nameplate attached to the motor. Motor electrical data can be found in Table C.

If voltage variations are larger than $\pm 10\%$, do not operate the pump.

Direct on-line starting is used due to the extremely fast run-up time of the motor (0.1 second maximum), and the low moment of inertia of the pump and motor. Direct on-line starting current (locked rotor amp) is between 4 and 6.5 times the full-load current.

Engine-Driven Generators

If the Redi-Flo4 pump is going to be operated using an engine driven generator, we suggest the manufacturer of the generator be contacted to ensure the proper generator is selected and used. See Table B for generator sizing guide.

Control Box, Single-Phase Motors

Single-phase motors must be connected as indicated in the motor control box. A typical single-phase wiring diagram using a Grundfos control box is shown. (Figure 5-A)

High Voltage Surge Arresters

A high voltage surge arrester should be used to protect the motor against lightning and switching surges. The correct voltage-rated surge arrester should be installed on the

supply(line) side of the control box.(Figure 5-B) The arrester must be grounded in accordance with the National Electric Code, local codes and regulations.

Control Box and Surge Arrester Grounding

The control box shall be permanently grounded in accordance with the National Electrical Code and local codes or regulations. The ground wire should be a bare copper conductor at least the same size as the drop cable wire size. The ground wire should be run as short a distance as possible and be securely fastened to a true grounding point.

True grounding points are considered to be: a grounding rod driven into the water strata, steel well casing submerged into the water lower than the pump setting level, and steel discharge pipes without insulating couplings. If plastic discharge pipe and well casing are used, a properly sized bare copper wire should be connected to a stud on the motor and run to the control panel. Do not ground to a gas supply line. Connect the grounding wire to the ground point first and then to the terminal in the control box.

Wiring Checks

Before making the final wiring connections of the drop cable to the control box terminal, it is a good practice to check the insulation resistance to ensure that the cable is good. Measurements for a new installation must be at least 1,000,000 ohm. Do not start the pump if the measurement is less than this. If it is higher, finish wiring and verify that all electrical connections are made in accordance with the wiring diagram. Check to ensure the control box and high voltage surge arrester have been grounded.

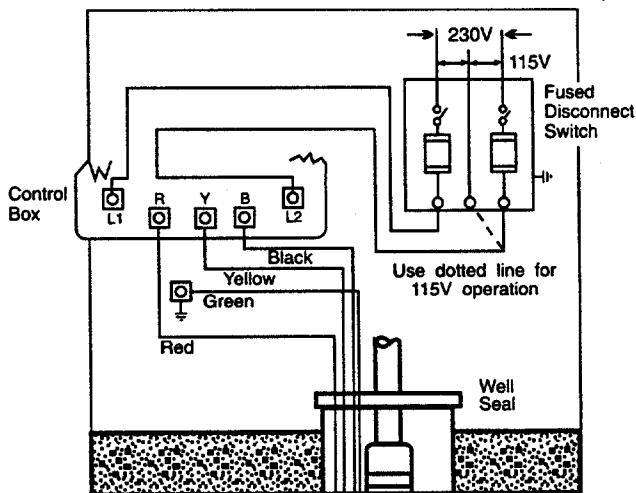

Single Phase Wiring Diagram for Grundfos Control Boxes

(Figure 5-A)

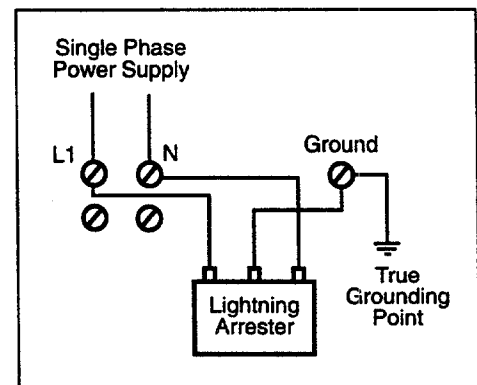

Single Phase Hookup

(Figure 5-B)

SECTION 6.

Start-Up

After the pump has been set into the well and the wiring connections have been made, the following procedures should be performed.

- A. Attach a temporary horizontal length of pipe with installed gate valve to the riser pipe.
- B. If required, make provisions to capture discharged fluids for disposal.
- C. Adjust the gate valve one-third open.
- D. Start the pump and let it operate until the water runs clear of sand and silt.
- E. As the water clears, slowly open the gate valve in small increments until the desired flow rate of clear water is reached. The pump should not be operated beyond its maximum flow rating and should not be stopped until the groundwater runs clear.
- F. If the groundwater is clean and clear when the pump is first started, the valve should still be opened until the desired flow rate is reached.
- G. Disconnect the temporary piping arrangements and complete the final piping connections.
- H. **Under no circumstances should the pump be operated for any prolonged period of time with the discharge valve closed.** This can result in motor damage due to overheating. A properly sized relief valve should be installed at the well head to prevent the pump from running against a closed valve.
- I. Start the pump and test the system. Check and record the voltage and current draw on each motor lead.

Operation

- A. The pump and system should be periodically checked for water quantity, pressure, drawdown, periods of cycling, and operation of controls. **Under no circumstances should the pump be operated for any prolonged periods of time with the discharge valve closed.** This can result in motor and pump damage due to overheating.
- B. If the pump fails to operate, or there is a loss of performance, refer to Troubleshooting, Section 7.

A properly sized relief valve should be installed at the well head to prevent the pump from running against a closed valve.

SECTION 7.

Troubleshooting

The majority of problems that develop with submersible pumps are electrical, and most of these problems can be corrected without pulling the pump from the well. The following charts cover most of the submersible service work. As with any troubleshooting procedure, start with the simplest

solution first; always make all the above-ground checks before pulling the pump from the well.

Usually only two instruments are needed – a combination voltmeter/ammeter, and an ohmmeter. These are relatively inexpensive and can be obtained from most water systems suppliers.

WHEN WORKING WITH ELECTRICAL CIRCUITS, USE CAUTION TO AVOID ELECTRICAL SHOCK. It is recommended that rubber gloves and boots be worn and that care is taken to have metal control boxes and motors grounded to power supply ground or steel drop pipe or casing extending into the well. WARNING: Submersible motors are intended for operation in a well. When not operated in a well, failure to connect motor frame to power supply ground may result in serious electrical shock.

Preliminary Tests

SUPPLY VOLTAGE

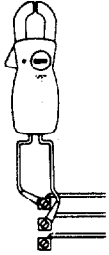

How to Measure

By means of a voltmeter, which has been set to the proper scale, measure the voltage at the control box. On single-phase units, measure between line and neutral.

What it Means

When the motor is under load, the voltage should be within $\pm 10\%$ of the nameplate voltage. Larger voltage variation may cause winding damage.

Large variations in the voltage indicate a poor electrical supply and the pump should not be operated until these variations have been corrected.

If the voltage constantly remains high or low, the motor should be changed to the correct supply voltage.

CURRENT MEASUREMENT

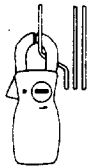

How to Measure

By use of an ammeter, set on the proper scale, measure the current on each power lead at the control box. See the Electrical Data, Table C, for motor amp draw information.

Current should be measured when the pump is operating at a constant discharge pressure with the motor fully loaded.

What it Means

If the amp draw exceeds the listed service factor amps (SFA), check for the following:

1. Loose terminals in control box or possible cable defect. Check winding and insulation resistances.
2. Too high or low supply voltage.
3. Motor windings are shorted.
4. Pump is damaged causing a motor overload.

WINDING RESISTANCE

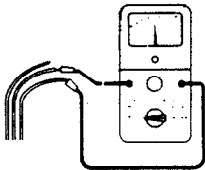

How to Measure

Turn off power and disconnect the drop cable leads in the control box. Using an ohmmeter, set the scale selectors to Rx1 for values under 10 ohms and Rx10 for values over 10 ohms.

Zero-adjust the meter and measure the resistance between leads. Record the values.

Motor resistance values can be found in the Electrical Data, Table C. Cable resistance values are in Table D.

What it Means

If all the ohm values are normal, and the cable colors correct, the windings are not damaged. If any one ohm value is less than normal, the motor may be shorted. If any one ohm value is greater than normal, there is a poor cable connection or joint. The windings or cable may also be open. If some of the ohm values are greater than normal and some less, the drop cable leads are mixed. To verify lead colors, see resistance values in Electrical Data, Table C.

INSULATION RESISTANCE

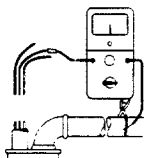

How to Measure

Turn off power and disconnect the drop cable leads in the control box. Using an ohm or mega ohmmeter, set the scale selector to Rx100K and zero-adjust the meter.

Measure the resistance between the lead and ground (discharge pipe or well casing, if steel).

What it Means

For ohm values, refer to table below. Motors of all Hp, voltage, phase and cycle duties have the same value of insulation resistance.

| OHM VALUE | MEGAOHM VALUE | CONDITION OF MOTOR AND LEADS |
|---------------------|---------------|---|
| 2,000,000 (or more) | 2.0 | Motor not yet installed: New Motor Used motor which can be reinstalled in the well. |
| 1,000,000 (or more) | 1.0 | |
| 500,000 - 1,000,000 | 0.5 - 1.0 | Motor in well (Ohm readings are for drop cable plus motor): A motor in reasonably good condition. A motor which may have been damaged by lightning or with damaged leads. Do not pull the pump for this reason. A motor which definitely has been damaged or with damaged cable. The pump should be pulled and repairs made to the cable or the motor replaced. The motor will still operate, but probably not for long. A motor which has failed or with completely destroyed cable insulation. The pump must be pulled and the cable repaired or the motor replaced. The motor will not run in this condition. |
| 20,000 - 50,000 | 0.02 - 0.5 | |
| 10,000 - 20,000 | 0.01 - 0.02 | |
| less than 10,000 | 0 - 0.01 | |

Troubleshooting Chart

| FAULT | POSSIBLE CAUSES | HOW TO CHECK | HOW TO CORRECT |
|--|---|--|---|
| A. Pump Does Not Run | 1. No power at pump panel. | Check for voltage at panel. | If no voltage at panel, check feeder panel for tripped circuits. |
| | 2. Fuses are blown or circuit breakers are tripped. | Remove fuses and check for continuity with ohmmeter. | Replace blown fuses or reset circuit breaker. If new fuses blow or circuit breaker trips, the electrical installation and motor must be checked. |
| | 3. Defective controls. | Check all safety and pressure switches for operation. Inspect contact in control devices. | Replace worn or defective parts. |
| | 4. Motor and/or cable are defective. | Turn off power. Disconnect motor leads from control box. Measure the lead to lead resistances with the ohmmeter (Rx1). Measure lead to ground values with ohmmeter (Rx100K). Record measured values. | If open motor winding or ground is found, remove pump and recheck values at the surface. Repair or replace motor or cable. |
| | 5. Defective capacitor. | Turn off the power, then discharge capacitor. Disconnect leads and check with an ohmmeter (Rx100K). When meter is connected, the needle should jump forward and slowly drift back. | If there is no needle movement, replace the capacitor. |
| B. Pump Runs But Does Not Deliver Water | 1. Groundwater level in well is too low or well is collapsed. | Check well drawdown. | Lower pump if possible. If not, throttle discharge valve and install water level control. |
| | 2. Integral pump check valve is blocked. | Install pressure gauge, start pump, gradually close the discharge valve and read pressure at shut-off. After taking reading, open valve to its previous position. Convert PSI to feet (For water: $PSI \times 2.31 \text{ ft/PSI} = \text{ft.}$), and add to this the total vertical distance from the pressure gauge to the water level in the well while the pump is running. Refer to the specific pump curve for the shut-off head for that pump model. If the measured head is close to the curve, pump is probably OK. | If not close to the pump curve, remove pump and inspect discharge section. Remove blockage, repair valve and valve seat if necessary. Check for other damage. Rinse out pump and reinstall. |
| | 3. Inlet strainer is clogged. | Same as B.2 above. | If not close to the pump curve, remove pump and inspect. Clean strainer, inspect integral check valve for blockage, rinse out pump and reinstall. |
| | 4. Pump is damaged. | Same as B.2 above. | If damaged, repair as necessary. Rinse out pump and reinstall. |
| C. Pump Runs But at Reduced Capacity | 1. Drawdown is larger than anticipated. | Check drawdown during pump operation. | Lower pump if possible. If not, throttle discharge valve and install water level control. |
| | 2. Discharge piping or valve leaking. | Examine system for leaks. | Repair leaks. |
| | 3. Pump strainer or check valve are clogged. | Remove pump and inspect. | Clean, repair, rinse out pump and reinstall. |
| | 4. Pump worn. | Same as B.2 above. | If not close to pump curve, remove pump and inspect. |

Troubleshooting (continued)

| FAULT | POSSIBLE CAUSES | HOW TO CHECK | HOW TO CORRECT |
|---|--|--|--|
| D. Pump Cycles Too Much | 1. Pressure switch is not properly adjusted or is defective. | Check pressure setting on switch and operation. Check voltage across closed contacts. | Re-adjust switch or replace if defective. |
| | 2. Level control is not properly set or is defective. | Check setting and operation. | Re-adjust setting (refer to manufacturer data). Replace if defective. |
| | 3. Plugged snifter valve or bleed orifice. | Examine valve and orifice for dirt or corrosion. | Clean and/or replace if defective. |
| E. Fuses Blow or Circuit Breakers Trip | 1. High or low voltage. | Check voltage at pump panel. If not within $\pm 10\%$, check wire size and length of run to pump panel. | If wire size is correct, contact power company. If not, correct and/or replace as necessary. |
| | 2. Control box wiring and components. | Check that control box parts match the parts list. Check to see that wiring matches wiring diagram. Check for loose or broken wires or terminals. | Correct as required. |
| | 3. Defective capacitor. | Turn off power and discharge capacitor. Check using an ohmmeter (Rx100K). When the meter is connected, the needle should jump forward and slowly drift back. | If no meter movement, replace the capacitor. |
| | 4. Starting relay (Franklin single phase motors only). | Check resistance of relay coil with an ohmmeter (Rx1000). Check contacts for wear. | Replace defective relay. |

Table A

Minimum Water Flow Requirements for Submersible Pump Motors

| MOTOR DIAMETER | CASING OR SLEEVE I.D. IN INCHES | MIN. FLOW PAST THE MOTOR (GPM) |
|----------------|---------------------------------|--------------------------------|
| 4" | 4 | 1.2 |
| | 5 | 7 |
| | 6 | 13 |
| | 7 | 21 |
| | 8 | 30 |

NOTES: 1. A flow inducer or sleeve must be used if the water enters the well above the motor or if there is insufficient water flow past the motor.
2. The minimum recommended water velocity over 4" motors is 0.25 feet per second.

Table B

Guide for Engine-Driven Generators in Submersible Pump Applications

| MOTOR HP | MINIMUM KILOWATT RATING OF GENERATOR FOR THREE-WIRE SUBMERSIBLE PUMP MOTORS | |
|----------|---|--------------------------------|
| | EXTERNALLY REGULATED GENERATOR | INTERNALLY REGULATED GENERATOR |
| 0.33 HP | 1.5 KW | 1.2 KW |
| 0.50 | 2.0 | 1.5 |
| 0.75 | 3.0 | 2.0 |
| 1.0 | 4.0 | 2.5 |
| 1.5 | 5.0 | 3.0 |

NOTES: 1. Table is based on typical 80°C rise continuous duty generators with 35% maximum voltage dip during start-up of single phase motors.
2. Contact the manufacturer of the generator to assure the unit has adequate capacity to run the submersible motor.
3. If the generator rating is in KVA instead of kilowatts, multiply the above ratings by 1.25 to obtain KVA.

Table C

Electrical Data - 60 Hz Submersible Pump Motors

GRUNDFOS MOTORS

4 Inch (Two Wire) Motors - Control Box Not Required

60 Hz

| HP | Ph | VOLT | Ser. Fact. | Circ. Brk. or Std. Fuse | Dual Element Fuse | AMPERAGE | | | FULL LOAD | | Line-to-Line Resistance(Ohms) | | KVA Code ** | Maximum Thrust (lbs) | GRUNDFOS PART NO. |
|---------------------|----|------|------------|-------------------------|-------------------|-----------|------------|-----------|-----------|--------------|-------------------------------|---------|-------------|----------------------|-------------------|
| | | | | | | Full Load | Lock Rotor | S.F. Amps | Eff. | Power Factor | Blk-Yel | Red-Yel | | | |
| | | | | | | | | | | | | | | | |
| SINGLE PHASE | | | | | | | | | | | | | | | |
| 1/3 | 1 | 230 | 1.75 | 15 | 5 | 3.0 | 25.5 | 4.4 | 47.3 | 63.0 | 6.8-8.2 | | S | 750 | 79.952301 |
| 1/2 | 1 | 230 | 1.60 | 15 | 7 | 4.3 | 34.5 | 5.9 | 50.6 | 64.7 | 5.2-6.3 | | R | 750 | 79.952302 |
| 3/4 | 1 | 230 | 1.50 | 20 | 9 | 6.6 | 40.5 | 8.0 | 57.0 | 70.0 | 3.2-3.8 | | N | 750 | 79.952303 |
| 1 | 1 | 230 | 1.40 | 25 | 12 | 8.0 | 47.4 | 9.6 | 59.8 | 74.3 | 2.5-3.1 | | M | 750 | 79.952304 |
| 1 1/2 | 1 | 230 | 1.30 | 35 | 15 | 10.6 | 60.8 | 13.1 | 64.3 | 77.2 | 1.9-2.3 | | L | 750 | 79.952305 |

4 Inch (Three Wire) Motors

SINGLE PHASE

| | | | | | | | | | | | | | | | |
|-------|---|-----|------|----|----|-----|------|------|------|------|---------|-----------|---|-----|-----------|
| 1/3 | 1 | 230 | 1.75 | 15 | 5 | 3.0 | 14.0 | 4.4 | 47.0 | 63.0 | 6.8-8.3 | 17.3-21.1 | L | 750 | 79.453301 |
| 1/2 | 1 | 230 | 1.60 | 15 | 7 | 4.3 | 20.0 | 5.9 | 50.7 | 64.6 | 4.7-5.7 | 15.8-19.6 | L | 750 | 79.453302 |
| 3/4 | 1 | 230 | 1.50 | 20 | 9 | 6.6 | 30.8 | 8.0 | 57.3 | 70.0 | 3.2-3.9 | 14-17.2 | L | 750 | 79.453303 |
| 1 | 1 | 230 | 1.40 | 25 | 12 | 8.0 | 36.3 | 9.6 | 59.8 | 74.5 | 2.6-3.1 | 10.3-12.5 | K | 750 | 79.453304 |
| 1 1/2 | 1 | 230 | 1.30 | 30 | 15 | 9.7 | 44.0 | 11.5 | 67.5 | 84.1 | 1.9-2.3 | 7.8-9.6 | H | 750 | 79.453305 |

Franklin Motors

(refer to the Franklin Submersible Motors Application Maintenance Manual)

Table D

Total Resistance of Drop Cable (OHMS)

The values shown in this table are for copper conductors. Values are for the total resistance of drop cable from the Control box to the motor and back.

To determine the resistance:

1. Disconnect the drop cable leads from the control box.
2. Record the size and length of drop cable.
3. Determine the cable resistance from the table.
4. Add drop cable resistance to motor resistance. Motor resistances can be found in the Electrical Data Chart, Table C.
5. Measure the resistance between each drop cable lead using an ohmmeter. Meter should be set on Rx1 and zero-balanced for this measurement.
6. The measured values should be approximately equal to the calculated values.

Wire Resistances

| Distance From Control Box to Pump Motor (FT.) | 12 AWG Wire Resistance (OHMS) | 14 AWG Wire Resistance (OHMS) |
|---|-------------------------------|-------------------------------|
| 10 | 0.03 | 0.05 |
| 20 | 0.06 | 0.10 |
| 30 | 0.10 | 0.15 |
| 40 | 0.13 | 0.21 |
| 50 | 0.16 | 0.26 |
| 60 | 0.19 | 0.31 |
| 70 | 0.23 | 0.36 |
| 80 | 0.26 | 0.41 |
| 90 | 0.29 | 0.46 |
| 100 | 0.32 | 0.51 |
| 110 | 0.36 | 0.57 |
| 120 | 0.39 | 0.62 |
| 130 | 0.42 | 0.67 |
| 140 | 0.45 | 0.72 |
| 150 | 0.49 | 0.77 |
| 160 | 0.52 | 0.82 |
| 170 | 0.55 | 0.87 |
| 180 | 0.58 | 0.93 |
| 190 | 0.62 | 0.98 |
| 200 | 0.65 | 1.03 |

Redi-Flo4

LIMITED WARRANTY

Redi-Flo4 Environmental Pumps manufactured by GRUNDFOS Pumps Corporation (GRUNDFOS) are warranted to the original user only to be free of defects in material and workmanship for a period of 18 months from date of installation, but not more than 24 months from date of manufacture. GRUNDFOS' liability under this warranty shall be limited to repairing or replacing at GRUNDFOS' option, without charge, F.O.B. GRUNDFOS' factory or authorized service station, any product of GRUNDFOS manufacture. GRUNDFOS will not be liable for any costs of removal, installation, transportation, or any other charges which may arise in connection with a warranty claim. Products which are sold but not manufactured by GRUNDFOS are subject to the warranty provided by the manufacturer of said products and not by GRUNDFOS' warranty. GRUNDFOS will not be liable for damage or wear to products caused by abnormal operating conditions, accident, abuse, misuse, unauthorized alteration or repair, or if the product was not installed in accordance with GRUNDFOS' printed installation and operating instructions.

To obtain service under this warranty, the defective product must be returned to the distributor or dealer of GRUNDFOS products from which it was purchased together with proof of purchase and installation date, failure date, and supporting installation data. Unless otherwise provided, the distributor or dealer will contact GRUNDFOS or an authorized service station for instructions. Any defective product to be returned to GRUNDFOS or a service station must be sent freight prepaid; documentation supporting the warranty claim and/or a Return Material Authorization must be included if so instructed.

GRUNDFOS WILL NOT BE LIABLE FOR ANY INCIDENTAL OR CONSEQUENTIAL DAMAGES, LOSSES, OR EXPENSES ARISING FROM INSTALLATION, USE OR ANY OTHER CAUSES. THERE ARE NO EXPRESS OR IMPLIED WARRANTIES, INCLUDING MERCHANTABILITY OR FITNESS FOR A PARTICULAR PURPOSE, WHICH EXTEND BEYOND THOSE WARRANTIES DESCRIBED OR REFERRED TO ABOVE.

Some jurisdictions do not allow the exclusion or limitation of incidental or consequential damages and some jurisdictions do not allow limitations on how long implied warranties may last. Therefore, the above limitations or exclusions may not apply to you. This warranty gives you specific legal rights and you may also have other rights which vary from jurisdiction to jurisdiction.

GRUNDFOS®



GRUNDFOS PUMPS CORP. • 2555 Clovis Ave. • Clovis, CA 93612
Sales Support Centers: Allentown, PA • Atlanta, GA • Chicago, IL
Canada: Mississauga, ONT

L-RF-IO-001 Rev. 10/93
PRINTED IN USA



GRUNDFOS®

**Redi-Flo4
Environmental
Submersible Pumps**

5E

Submittal Data

3450 RPM

60 Hertz

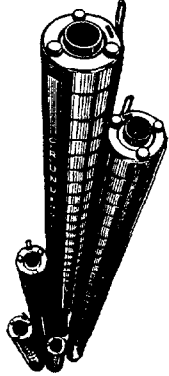

JOB or CUSTOMER:

ENGINEER:

CONTRACTOR:

SUBMITTED BY:

DATE:

APPROVED BY:

DATE:

ORDER NO.:

DATE:

SPECIFICATION REF.:

| QUANTITY | AG NO. | MODEL NO. | GPM | FEET | VOLTS | PHASE | REMARKS |
|----------|--------|-----------|-----|------|-------|-------|---------|
| | | | | | | | |
| | | | | | | | |
| | | | | | | | |

Dimensions

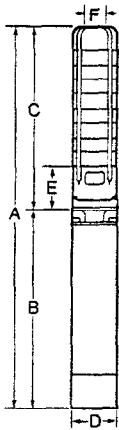

Technical Data

FLOW RANGE: 1.2 to 7 US GPM

MOTORS: Grundfos MS402E Environmental Submersible Motor (Standard)

Maximum Operating Temperature: 104°F (40°C)

Maximum Operating Pressure: 220 PSI

Maximum Number of Starts Per Hour: 100

Minimum Recommended Flow Past Motor: 0.25 ft/sec

(NOTE: Franklin Pollution Recovery motor is optional.)

DISCHARGE SIZE: 1" NPT

PUMP END CONSTRUCTION MATERIALS: Stainless Steel and Teflon®

INSTALLATION: Unit to be installed vertically for submerged operation.

Electrical Data, Dimensions, and Weights ①

| PUMP TYPE | MOTOR | | | | DIMENSIONS (In Inches) | | | | | | NET WEIGHT (LBS.)② | SHIP. WEIGHT (LBS.)② |
|-----------|-------|------|----|-------|------------------------|-----------------|-------------------|-------------|---------|--------------------------|--------------------|----------------------|
| | HP | SF | PH | VOLTS | OVERALL LENGTH A | MOTOR LENGTH B① | PUMP END LENGTH C | MAX. DIA. D | INLET E | DISCH. PIPE SIZE (NPT) F | | |
| 5E3 | 1/3 | 1.75 | 1 | 230 | 18 5/16 | 10 | 5 7/16 | 3 3/16 | 3 3/4 | 1 | 24 | 26 |
| 5E5 | 1/3 | 1.75 | 1 | 230 | 20 5/16 | 10 | 10 5/16 | 3 31/32 | 3 1/4 | 1 | 24 | 26 |
| 5E8 | 1/2 | 1.60 | 1 | 230 | 22 3/4 | 10 | 12 3/4 | 3 31/32 | 3 1/4 | 1 | 28 | 29 |
| 5E12 | 1/2 | 1.60 | 1 | 230 | 26 13/16 | 10 13/16 | 16 | 3 31/32 | 3 1/4 | 1 | 28 | 29 |
| 5E17 | 3/4 | 1.40 | 1 | 230 | 31 7/16 | 11 | 20 3/16 | 3 31/32 | 3 1/4 | 1 | 33 | 35 |
| 5E21 | 1 | 1.40 | 1 | 230 | 35 7/16 | 12 | 23 7/16 | 3 31/32 | 3 1/4 | 1 | 33 | 35 |
| 5E25 | 1 1/2 | 1.30 | 1 | 230 | 40 5/16 | 13 9/16 | 26 3/4 | 3 31/32 | 3 1/4 | 1 | 35 | 37 |

① Data for Grundfos MS402E motors. ② Does not include motor leads.

Performance Curves

Redi-Flo4 Environmental Pump

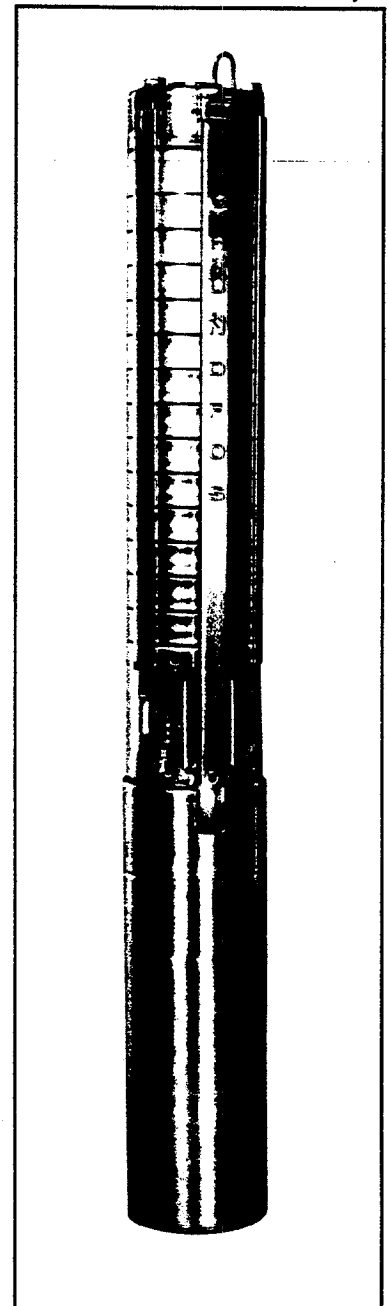
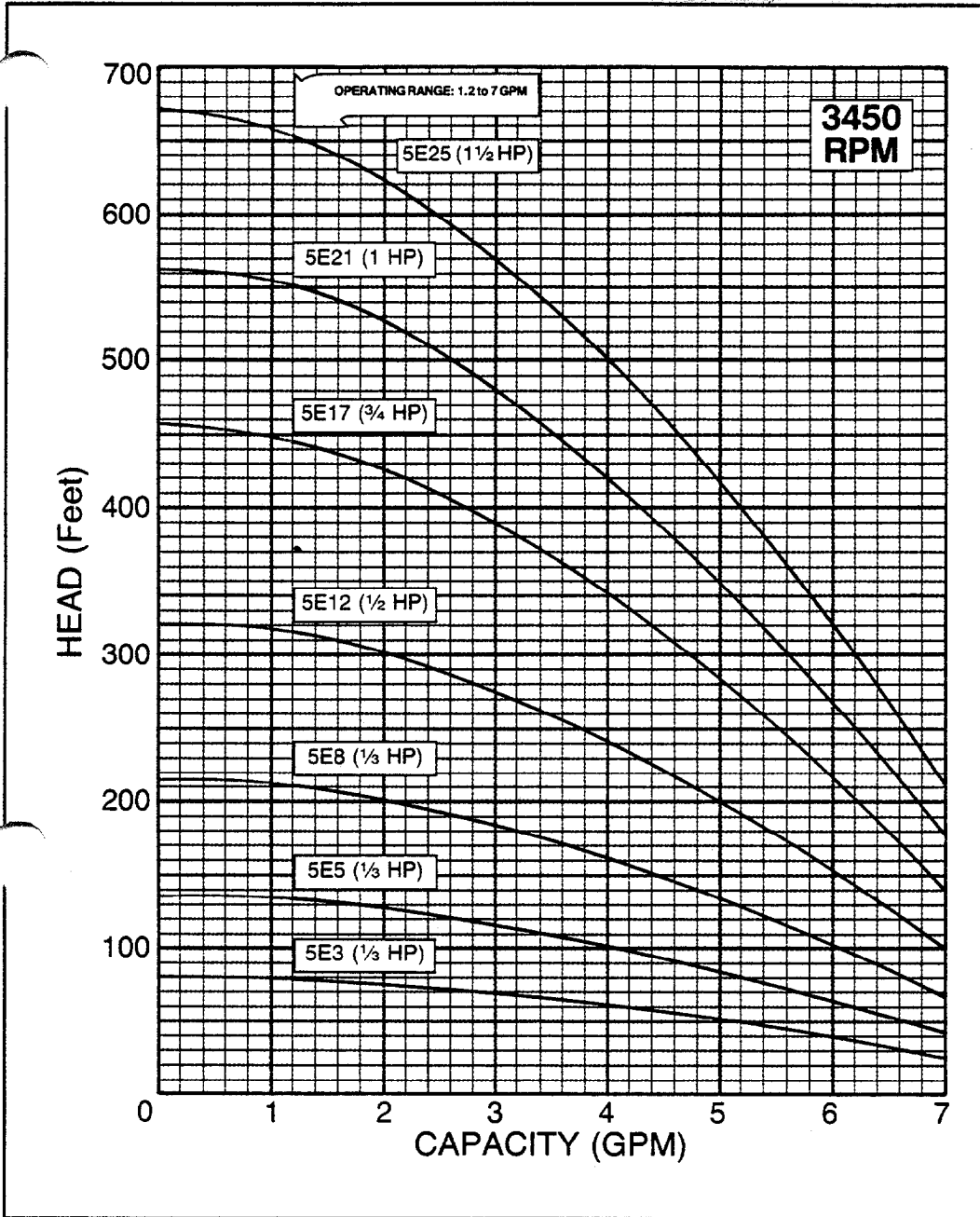

Materials of Construction

| REDI-FLO4 PUMP END | |
|------------------------|-------------------------------|
| Check Valve Housing | 304 Stainless Steel |
| Check Valve | 304 Stainless Steel |
| Check Valve Seat | 304 Stainless Steel & Teflon® |
| Diffuser Chamber | 304 Stainless Steel |
| Impeller Seal Ring | Teflon® |
| Impeller | 304 Stainless Steel |
| Suction Interconnector | 304 Stainless Steel |
| Inlet Screen | 304 Stainless Steel |
| Pump Shaft | 304 Stainless Steel |
| Coupling | 329/420/431 Stainless Steel |
| Straps | 304 Stainless Steel |
| Wire Guard | 304 Stainless Steel |
| Impeller Inducer | 304 Stainless Steel |
| Intermediate Bearings | Teflon® |

| GRUNDFOS ENVIRONMENTAL MOTOR | |
|------------------------------|---------------------|
| Nema Top | 304 Stainless Steel |
| Studs & Fasteners | 304 Stainless Steel |
| Nuts | 316 Stainless Steel |
| Sand Slinger | Viton® |
| Shaft Extension | 431 Stainless Steel |
| Diaphragm | Viton® |
| Stator Housing | 304 Stainless Steel |
| Fill Plug Screw | 304 Stainless Steel |
| Fill Plug Washer | Teflon® |

| GRUNDFOS ENVIRONMENTAL MOTOR LEADS | |
|------------------------------------|------------------------------------|
| Connector Sleeve | 304 Stainless Steel |
| Connector Potting | Scotch Cast #4® Epoxy w/Viton® Cap |
| Connector Plug | Viton® |
| Lead Insulation | Teflon® |

NOTE: Specifications are subject to change without notice.

**MODEL
5S**

5 GPM

GRUNDFOS

FLOW RANGE
1.2 to 7 GPM

PUMP OUTLET
1" NPT

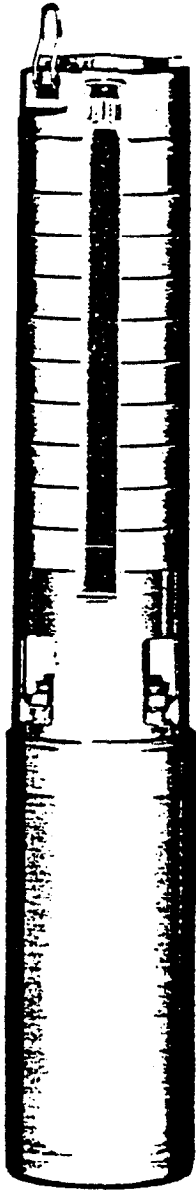

PERFORMANCE CURVES

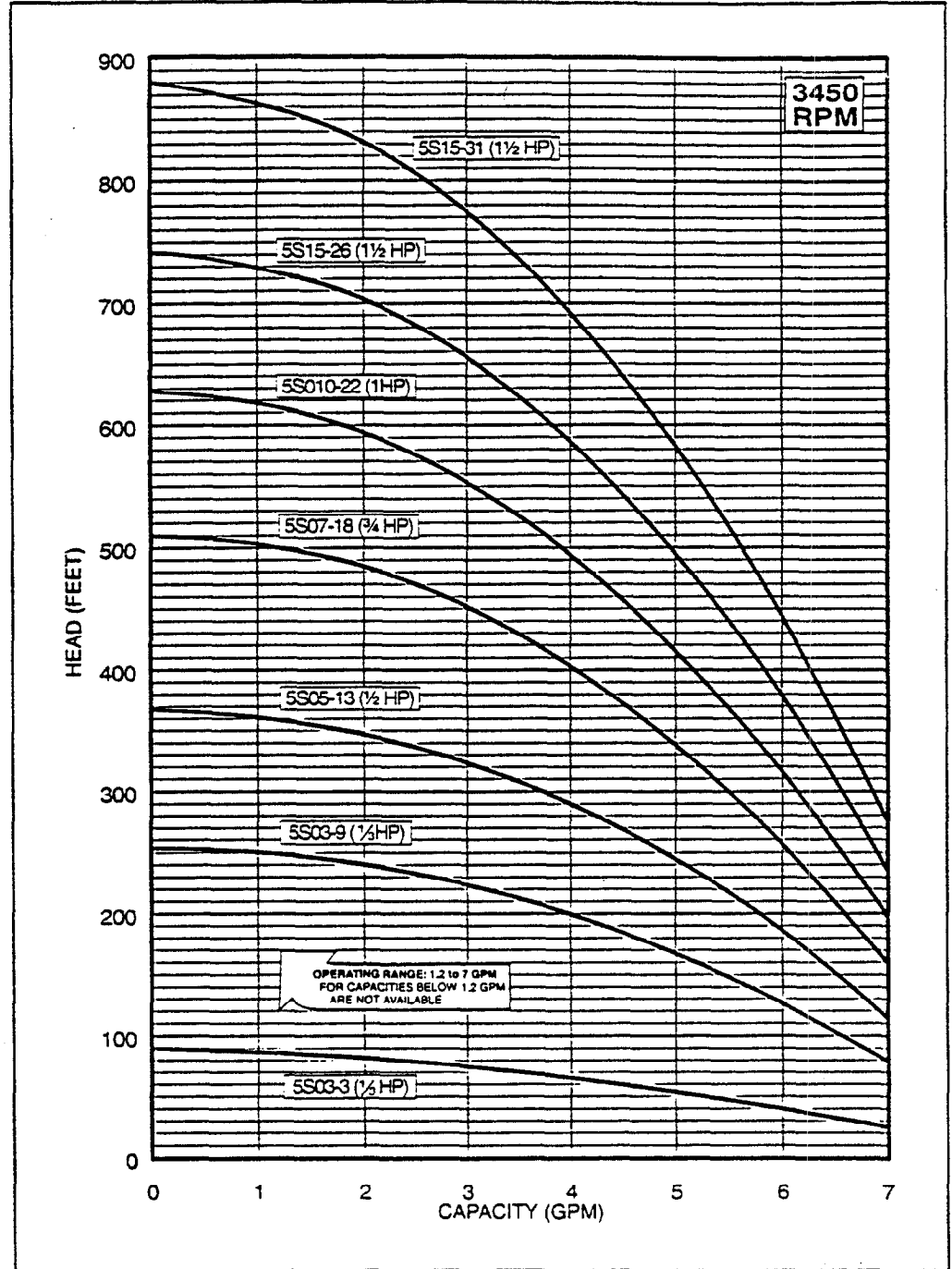

DIMENSIONS AND WEIGHTS

| MODEL NO. | HP | LENGTH (INCHES) | WIDTH (INCHES) | APPROX. UNIT SHIPPING WT. (LBS.) |
|-----------|-------|-----------------|----------------|----------------------------------|
| 5S03-9 | 1/3 | 24 | 3 15/16 | 27 |
| 5S05-13 | 1/2 | 28 | 3 15/16 | 31 |
| 5S07-18 | 3/4 | 32 5/8 | 3 15/16 | 34 |
| 5S10-22 | 1 | 36 3/8 | 3 15/16 | 42 |
| 5S15-26 | 1 1/2 | 42 | 3 15/16 | 46 |
| 5S15-31 | 1 1/2 | 47 7/8 | 3 15/16 | 58 |

Specifications are subject to change without notice.

GRUNDFOS

5 GPM

MODEL 5S

SELECTION CHARTS (Ratings are in GALLONS PER HOUR - GPH)

FLOW RANGE 1.2 to 7 GPM

PUMP OUTLET 1" NPT

| PUMP MODEL | HP | PSI | DEPTH TO PUMPING WATER LEVEL (LIFT) IN FEET | | | | | | | | | | | | | | | | | | | | | | | | | | |
|---------------|-------|-----|---|-----|-----|-----|-----|-----|-----|-----|-----|-----|-----|-----|-----|-----|-----|-----|-----|-----|-----|-----|-----|-----|-----|------|------|--|--|
| | | | 20 | 40 | 60 | 80 | 100 | 120 | 140 | 160 | 180 | 200 | 220 | 240 | 260 | 280 | 300 | 340 | 400 | 460 | 520 | 600 | 700 | 800 | 900 | 1000 | 1100 | | |
| 5S03-9 | 1/3 | 0 | | | | 428 | 401 | 374 | 347 | 320 | 288 | 256 | 191 | 127 | | | | | | | | | | | | | | | |
| | | 20 | | 420 | 393 | 366 | 339 | 312 | 277 | 242 | 169 | 95 | | | | | | | | | | | | | | | | | |
| | | 30 | | 389 | 362 | 335 | 306 | 276 | 225 | 174 | 87 | | | | | | | | | | | | | | | | | | |
| | | 40 | 400 | 358 | 330 | 303 | 265 | 228 | 143 | | | | | | | | | | | | | | | | | | | | |
| | | 50 | 369 | 327 | 296 | 265 | 208 | 150 | 75 | | | | | | | | | | | | | | | | | | | | |
| | | 60 | 337 | 294 | 253 | 211 | 114 | | | | | | | | | | | | | | | | | | | | | | |
| Shut-off PSI: | | 102 | 94 | 85 | 76 | 68 | 59 | 50 | 42 | 33 | 24 | 16 | 7 | | | | | | | | | | | | | | | | |
| 5S05-13 | 1/2 | 0 | | | | | | 423 | 405 | 386 | 367 | 349 | 330 | 311 | 289 | 267 | 233 | 137 | | | | | | | | | | | |
| | | 20 | | | 437 | 418 | 399 | 380 | 362 | 343 | 324 | 305 | 282 | 259 | 222 | 185 | 117 | | | | | | | | | | | | |
| | | 30 | | 434 | 415 | 396 | 377 | 359 | 340 | 322 | 301 | 281 | 251 | 222 | 170 | 117 | | | | | | | | | | | | | |
| | | 40 | 431 | 412 | 393 | 375 | 356 | 338 | 318 | 299 | 275 | 250 | 210 | 170 | 94 | | | | | | | | | | | | | | |
| | | 50 | 409 | 390 | 372 | 353 | 335 | 316 | 295 | 273 | 242 | 210 | 153 | 95 | | | | | | | | | | | | | | | |
| | | 60 | 388 | 369 | 350 | 332 | 312 | 293 | 267 | 241 | 197 | 153 | 76 | | | | | | | | | | | | | | | | |
| Shut-off PSI: | | 152 | 143 | 134 | 126 | 117 | 108 | 100 | 91 | 82 | 74 | 65 | 56 | 48 | 39 | 30 | 13 | | | | | | | | | | | | |
| 5S07-18 | 3/4 | 0 | | | | | | | | 427 | 413 | 400 | 386 | 373 | 360 | 346 | 333 | 305 | 254 | 183 | | | | | | | | | |
| | | 20 | | | | | | 423 | 409 | 396 | 382 | 369 | 355 | 342 | 329 | 315 | 300 | 267 | 193 | | | | | | | | | | |
| | | 30 | | | | | | 421 | 407 | 394 | 380 | 367 | 353 | 340 | 327 | 313 | 299 | 282 | 242 | 149 | | | | | | | | | |
| | | 40 | | | 432 | 419 | 405 | 392 | 378 | 365 | 351 | 338 | 325 | 311 | 296 | 281 | 261 | 212 | 92 | | | | | | | | | | |
| | | 50 | | 430 | 417 | 403 | 390 | 376 | 363 | 349 | 336 | 323 | 308 | 294 | 277 | 259 | 235 | 173 | | | | | | | | | | | |
| | | 60 | 428 | 415 | 401 | 388 | 374 | 361 | 347 | 334 | 320 | 307 | 291 | 275 | 255 | 234 | 203 | 123 | | | | | | | | | | | |
| Shut-off PSI: | | 213 | 204 | 195 | 187 | 178 | 169 | 161 | 152 | 143 | 135 | 126 | 117 | 109 | 100 | 91 | 74 | 48 | 22 | | | | | | | | | | |
| 5S10-22 | 1 | 0 | | | | | | | | | | 426 | 415 | 404 | 393 | 382 | 371 | 349 | 316 | 279 | 228 | 103 | | | | | | | |
| | | 20 | | | | | | | | 423 | 412 | 401 | 390 | 379 | 368 | 357 | 346 | 324 | 289 | 241 | 167 | | | | | | | | |
| | | 30 | | | | | | | 421 | 410 | 399 | 388 | 377 | 366 | 355 | 344 | 334 | 311 | 273 | 216 | 126 | | | | | | | | |
| | | 40 | | | | | | 420 | 409 | 398 | 387 | 376 | 365 | 354 | 343 | 332 | 321 | 297 | 255 | 186 | 75 | | | | | | | | |
| | | 50 | | | | 429 | 418 | 407 | 396 | 385 | 374 | 363 | 352 | 341 | 330 | 319 | 307 | 282 | 233 | 149 | | | | | | | | | |
| | | 60 | | | 427 | 416 | 405 | 394 | 383 | 372 | 361 | 350 | 340 | 329 | 317 | 306 | 293 | 265 | 207 | 103 | | | | | | | | | |
| Shut-off PSI: | | | 245 | 237 | 228 | 219 | 211 | 202 | 194 | 185 | 176 | 168 | 159 | 150 | 142 | 124 | 98 | 72 | 46 | 12 | | | | | | | | | |
| 5S15-26 | 1 1/2 | 0 | | | | | | | | | | | | 427 | 418 | 408 | 399 | 381 | 353 | 325 | 296 | 245 | 126 | | | | | | |
| | | 20 | | | | | | | | | | | 424 | 415 | 406 | 396 | 387 | 378 | 359 | 332 | 303 | 269 | 202 | | | | | | |
| | | 30 | | | | | | | | | 423 | 414 | 404 | 395 | 386 | 376 | 367 | 349 | 321 | 290 | 253 | 175 | | | | | | | |
| | | 40 | | | | | | | | 422 | 412 | 403 | 394 | 384 | 375 | 366 | 357 | 338 | 310 | 277 | 235 | 142 | | | | | | | |
| | | 50 | | | | | | | 420 | 411 | 401 | 392 | 383 | 374 | 364 | 355 | 346 | 327 | 298 | 262 | 214 | 102 | | | | | | | |
| | | 60 | | | | | | 419 | 409 | 400 | 391 | 381 | 372 | 363 | 354 | 345 | 335 | 317 | 286 | 245 | 188 | | | | | | | | |
| Shut-off PSI: | | | | | | | 269 | 260 | 252 | 243 | 234 | 226 | 217 | 208 | 200 | 191 | 174 | 148 | 122 | 96 | 61 | 18 | | | | | | | |
| 5S15-31 | 1 1/2 | 0 | | | | | | | | | | | | | | 425 | 417 | 401 | 378 | 355 | 331 | 299 | 246 | 158 | | | | | |
| | | 20 | | | | | | | | | | | | | | 423 | 415 | 407 | 399 | 383 | 360 | 337 | 313 | 277 | 212 | 94 | | | |
| | | 30 | | | | | | | | | | | | | 421 | 413 | 406 | 398 | 390 | 374 | 351 | 328 | 303 | 265 | 191 | 53 | | | |
| | | 40 | | | | | | | | | | | | 420 | 413 | 405 | 397 | 389 | 381 | 365 | 342 | 318 | 293 | 252 | 166 | | | | |
| | | 50 | | | | | | | | 427 | 419 | 411 | 403 | 395 | 388 | 380 | 372 | 357 | 333 | 309 | 283 | 237 | 138 | | | | | | |
| | | 60 | | | | | | | 426 | 418 | 410 | 402 | 395 | 387 | 379 | 371 | 363 | 348 | 324 | 300 | 271 | 219 | 104 | | | | | | |
| Shut-off PSI: | | | | | | | | 320 | 311 | 303 | 294 | 285 | 277 | 268 | 259 | 251 | 233 | 207 | 181 | 155 | 121 | 77 | 34 | | | | | | |

**MODEL
40S**

40 GPM

GRUNDFOS

FLOW RANGE
24 to 55 GPM

PUMP OUTLET
2" NPT



PERFORMANCE CURVES

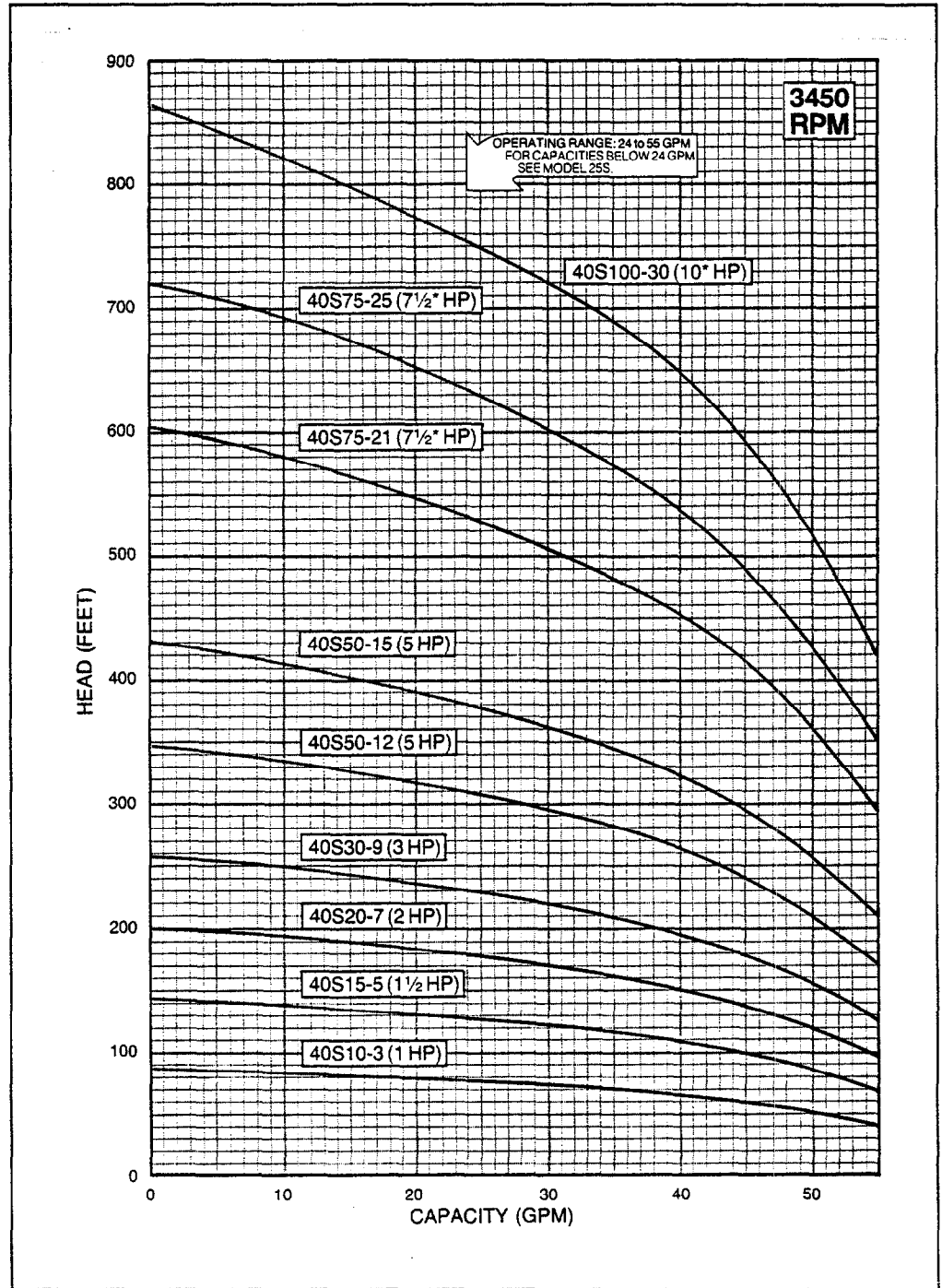

DIMENSIONS AND WEIGHTS

| MODEL NO. | HP | LENGTH (INCHES) | WIDTH (INCHES) | APPROX. UNIT SHIPPING WT. (LBS.) |
|-----------|--------|-----------------|----------------|----------------------------------|
| 40S10-3 | 1 | 24 7/8 | 3 15/16 | 32 |
| 40S15-5 | 1 1/2 | 30 1/2 | 3 15/16 | 37 |
| 40S20-7 | 2 | 33 | 3 15/16 | 41 |
| 40S30-9 | 3 | 43 3/8 | 3 15/16 | 65 |
| 40S50-12 | 5 | 51 1/8 | 3 15/16 | 78 |
| 40S50-15 | 5 | 56 1/8 | 3 15/16 | 84 |
| 40S75-21 | 7 1/2* | 74 1/2 | 3 15/16 | 120 |
| 40S75-25 | 7 1/2* | 81 1/8 | 3 15/16 | 124 |
| 40S100-30 | 10* | 103 1/2 | 3 15/16 | 181 |

4-inch motor is provided as standard for these models.

Specifications are subject to change without notice.

See Deep Set models for higher head.

**MODEL
80S**

80 GPM

GRUNDFOS

FLOW RANGE
48 to 110 GPM

PUMP OUTLET
3" NPT



PERFORMANCE CURVES

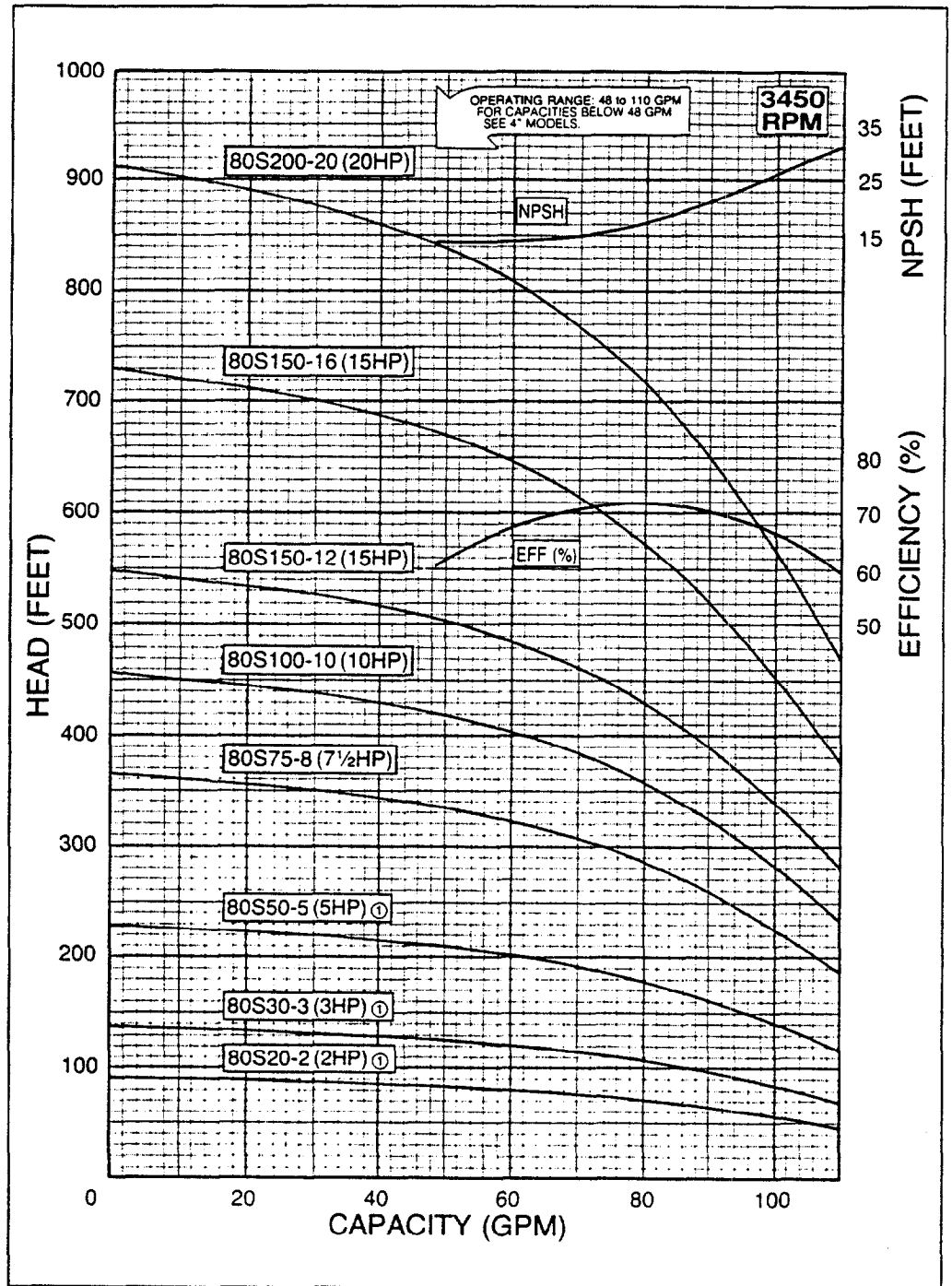

DIMENSIONS AND WEIGHTS

| MODEL NO. | HP | MIN. WELL SIZE (INCHES) | LENGTH (INCHES) | MAX. WIDTH (INCHES) | APPROX. UNIT SHIPPING WT. (LBS.) |
|-----------|-------|-------------------------|-----------------|---------------------|----------------------------------|
| 80S20-2 | 2① | 6 | 33 5/8 | 5 3/16 | 51 |
| 80S30-3 | 3① | 6 | 37 7/8 | 5 3/16 | 65 |
| 80S50-5 | 5① | 6 | 44 3/8 | 5 3/16 | 87 |
| 80S75-8 | 7 1/2 | 6 | 51 1/2 | 5 1/2 | 144 |
| 80S100-10 | 10 | 6 | 56 1/4 | 5 1/2 | 154 |
| 80S150-12 | 15 | 6 | 62 1/4 | 5 1/2 | 173 |
| 80S150-16 | 15 | 6 | 69 1/2 | 5 1/2 | 184 |
| 80S200-20 | 20 | 6 | 99 | 5 1/2 | 207 |

NOTES:

① 4-inch motor.

Specifications are subject to change without notice.

See Deep Set models for higher head.

GRUNDFOS

135 GPM

MODEL 135S

PERFORMANCE CURVES

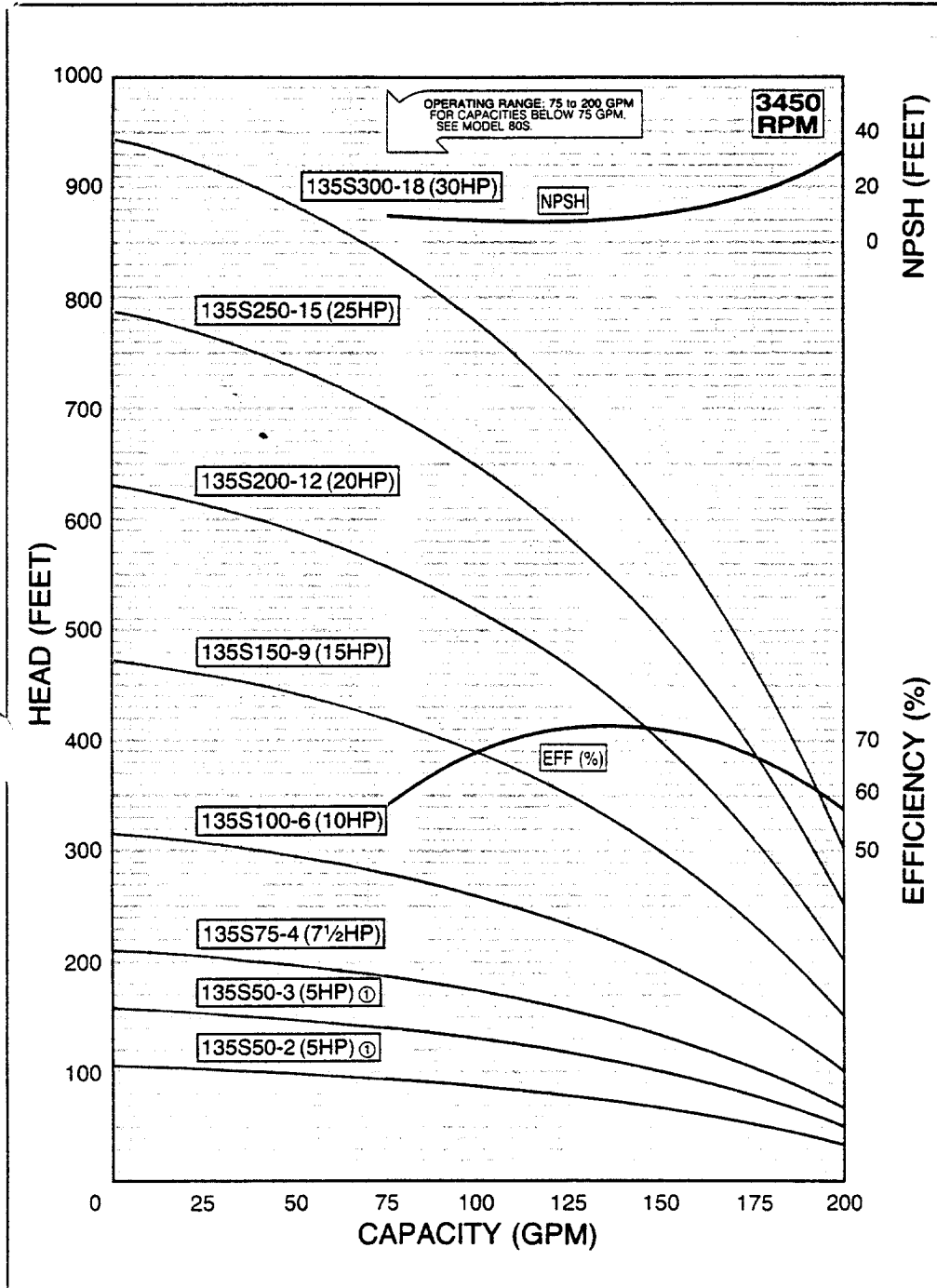

FLOW RANGE
75 to 200 GPM

PUMP OUTLET
3" NPT



DIMENSIONS AND WEIGHTS

| MODEL NO. | HP | MIN. WELL SIZE (INCHES) | LENGTH (INCHES) | MAX. WIDTH (INCHES) | APPROX. UNIT SHIPPING WT. (LBS.) |
|------------|----|-------------------------|-----------------|---------------------|----------------------------------|
| 135S50-2 | 5① | 6 | 42 ½ | 5 ½ | 84 |
| 135S50-3 | 5① | 6 | 47 | 5 ½ | 88 |
| 135S75-4 | 7½ | 6 | 51 ½ | 5¾ | 146 |
| 135S100-6 | 10 | 6 | 59 ⅞ | 5¾ | 167 |
| 135S150-9 | 15 | 6 | 73 | 5¾ | 186 |
| 135S200-12 | 20 | 6 | 86 ¼ | 5¾ | 225 |
| 135S250-15 | 25 | 6 | 99 ¼ | 5¾ | 243 |
| 135S300-18 | 30 | 6 | 112¾ | 5¾ | 268 |

NOTES:

① 4-inch motor.

Specifications are subject to change without notice.

See Deep Set models for higher head.

SERVICE DATA
PAGE: 263SD
DATE: September 1, 1992
SUPERSEDES: 10/1/88

Submersible Motors

Application ■ Installation ■ Maintenance Manual
Water Well Motors, Single and Three Phase 60HZ, 4", 6" and 8" Diameter

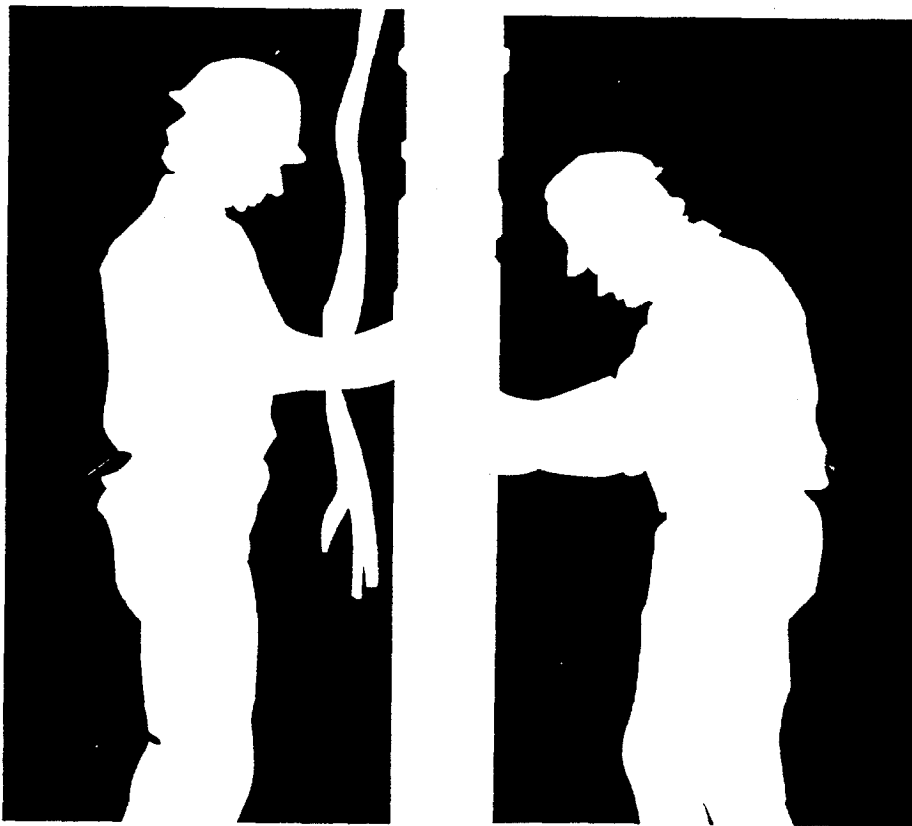

Franklin Electric
QUALITY IN THE WELL

4" Super Stainless

Dimensions

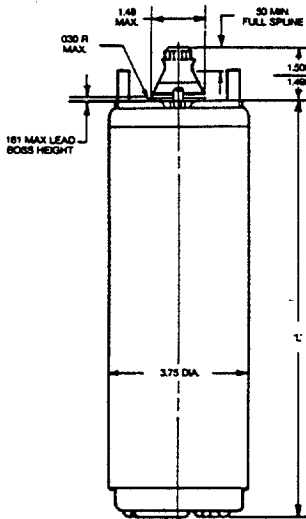

Availability

2-Wire, Split Phase, 60 HZ, 3450 RPM

| hp | kw | "L" Dimension | | Shipping Weight |
|-------|-----|---------------|-------|-----------------|
| | | volts | in | |
| 1/3 | .25 | 115 | 8.78 | 16 |
| | | 230 | | |
| 1/2 | .37 | 115 | 9.53 | 18 |
| | | 230 | | |
| 3/4 | .55 | 230 | 10.66 | 20 |
| 1 | .75 | 230 | 11.75 | 23 |
| 1 1/2 | 1.1 | 230 | 15.12 | 31 |

3-Wire, Capacitor Start, 60 Hz, 3450 RPM [Ⓞ]

| hp | kw | "L" Dimension | | Shipping Weight |
|-------|-----|---------------|-------|-----------------|
| | | volts | in | |
| 1/3 | .25 | 115 | 8.78 | 16 |
| | | 230 | | |
| 1/2 | .37 | 115 | 9.53 | 18 |
| | | 230 | | |
| 3/4 | .55 | 230 | 10.66 | 20 |
| 1 | .75 | 230 | 11.75 | 23 |
| 1 1/2 | 1.1 | 230 | 15.12 | 31 |
| 2 | 1.5 | 230 | 15.12 | 30 |

[Ⓞ] Franklin Electric control box required

4' High Thrust

Dimensions

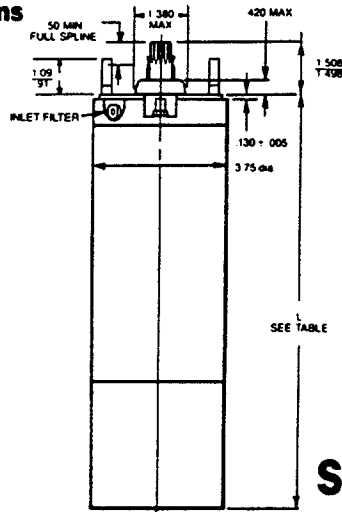

Availability

Single Phase Capacitor start, capacitor run [Ⓞ]

| hp | kw | "L" Dimension | | Shipping Weight |
|----|-----|---------------|-----|-----------------|
| | | in | lbs | |
| 3 | 2.2 | 23.7 | 52 | |
| 5 | 3.7 | 29.47 | 69 | |

Three Phase

| | | | |
|-----|-----|-------|-----|
| 3 | 2.2 | 20.62 | 43 |
| 5 | 3.7 | 23.47 | 53 |
| 7.5 | 5.5 | 29.47 | 69 |
| 10 | 7.5 | 43.89 | 130 |

Super - 6"

Dimensions

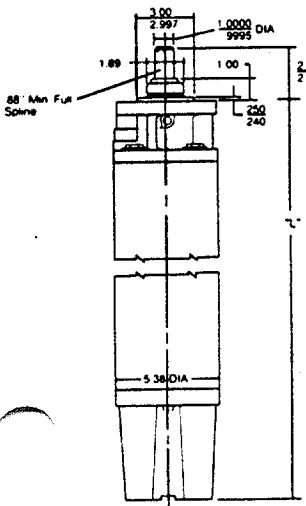

Availability

Single Phase Capacitor start, capacitor run [Ⓞ]

| hp | kw | "L" Dimension | | Shipping Weight |
|------|------|---------------|-----|-----------------|
| | | in | lbs | |
| 5/0 | 3.7 | 25.44 | 105 | |
| 7.5 | 5.5 | 28.00 | 120 | |
| 10.0 | 7.5 | 30.56 | 135 | |
| 15.0 | 11.0 | 33.13 | 146 | |

Three Phase

| | | | |
|----|------|-------|-----|
| 5 | 3.7 | 22.88 | 90 |
| 7 | 5.5 | 24.19 | 95 |
| 10 | 7.5 | 25.44 | 105 |
| 15 | 11.0 | 28.00 | 120 |
| 20 | 15.0 | 30.56 | 135 |
| 25 | 18.5 | 33.13 | 148 |
| 30 | 22.0 | 35.69 | 162 |
| 40 | 30.0 | 40.81 | 195 |
| 50 | 37.0 | 57.83 | 310 |
| 60 | 45.0 | 63.83 | 340 |

Super - 8"

Dimensions

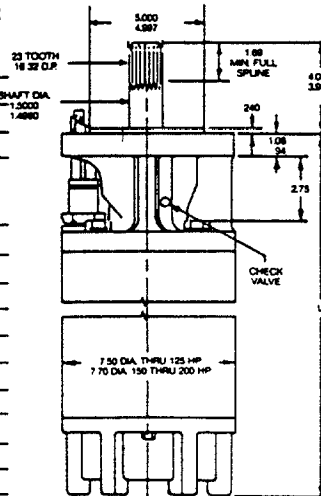

Availability [Ⓞ]

8-Inch Pump Flange (5-inch rabbet)
"L" Dimension Shipping Weight

| hp | kw | in | lbs |
|-----|-----|-------|-------|
| 40 | 30 | 39.78 | 366 |
| 50 | 37 | 42.78 | 401 |
| 60 | 45 | 45.78 | 436 |
| 75 | 55 | 50.78 | 483 |
| 100 | 75 | 58.78 | 644 |
| 125 | 90 | 68.78 | 719 |
| 150 | 110 | 77.78 | 815 |
| 175 | 130 | 85.78 | 919 |
| 200 | 150 | 94.78 | 1,031 |

6-Inch Pump Lang (3-inch rabbet)

| | | | |
|----|----|-------|-----|
| 40 | 30 | 39.53 | 336 |
| 50 | 37 | 42.53 | 372 |
| 60 | 45 | 45.53 | 408 |

[Ⓞ] 50 Hz - Nominal 2,875 RPM

Variable Speed Submersible Pump Operation, Inverter Drives

Franklin three phase submersible motors are operable from variable frequency inverter drives when applied within guidelines specified below. These guidelines are based on present Franklin information for inverter drives, lab tests and actual installations, and must be followed for warranty to apply to inverter drive installations.

1. Variable speed drives should be variable frequency, constant volts per Hertz type, and may have sine wave, pulse width modulated (PWM) or six-step waveshape. The base voltage should be name plate voltage and frequency of the motor.
2. Overcurrent protection in the inverter or separately furnished must trip within 10 seconds at 5 times motor maximum nameplate amps in any line, and ultimately trip within 115% of motor maximum nameplate amps in any line.
3. Any application below 30 Hertz or above 80 Hertz must be specifically approved by Franklin Engineering. Operation at lower frequency can cause motor bearing failure, and at higher frequency can raise internal hydraulic losses to an unacceptable level.
4. Pump load must be selected so motor maximum nameplate amps are not exceeded under all running conditions.
5. Franklin-specified water temperature and flow past the motor must be maintained at speeds which load the motor up to maximum nameplate amps. At reduced speeds and loading, cooling flow must be adequate to maintain equivalent motor temperature.
6. Franklin Subtrol protection systems are not usable on inverter driven installations, because the non-sinusoidal waveshape from the inverter prevents proper Subtrol operation. The waveshape also reduces motor efficiency, typically about two percentage points.
7. To confirm whether an installation or system design is acceptable and warrantable, full details should be submitted to Franklin on Form 2207 along with inverter specifications.

Send to:
Franklin Electric
400 E. Spring Street, Bluffton, IN 46714
Attention: Field Service Department

Upon receipt and analysis of the data and installation details supplied on Form No. 2207, Franklin engineers will advise by letter if the installation will be covered by Franklin's warranty.

Submersible Motors Inline - Booster Systems

Franklin submersible motors are acceptable for booster pump (canned) applications provided the following conditions are taken into consideration in the system design.

1. **HORIZONTAL OPERATION:** Horizontal operation is acceptable as long as the pump transmits thrust to the motor and the entire assembly is supported sufficiently to prevent binding stresses.
2. The motor support assembly must not restrict the flow of cooling water around the full diameter of the motor. The motor supports must be on the motor endbell castings, and not on the stator shell.
3. **CONTROLS:** Franklin Subtrol-Plus is strongly recommended for all large submersibles. If Subtrol is not employed, properly sized ambient compensated quick-trip overloads must be utilized. In addition, a surge arrester should be installed on all systems and properly grounded.
4. **WIRING:** Franklin lead assemblies are sized for submerged operation and may not be adequate for use in open air. Any wiring not submerged must comply with Franklin's cable charts.
5. **WATER TEMPERATURE:** The temperature of the water should be monitored at the inlet to each booster. When temperatures exceed 86°F (30°C), motor derating is required.
6. **INLET PRESSURE:** The inlet pressure on each booster should be monitored and not be allowed below the pump's specified Net Positive Suction Head Requirement (NPSHR). If NPSHR is unknown, at least 20 P.S.I. should be maintained at all times.
7. **DISCHARGE FLOW:** The flow rate for each pump should be monitored and never be allowed to drop below the minimum required to maintain cooling flow velocities. Pressure relieving valves should be employed to prevent running the pump at shut-off.
8. **DISCHARGE PRESSURE:** The discharge pressure should be great enough to prevent upthrust.
9. **CAN FLOODING:** An air bleeder valve must be employed on the booster can so total flooding may be accomplished prior to booster start-up.

IMPORTANT NOTES:

1. **HIGH PRESSURE TEST:** Motors intended for booster applications where the pressure exceeds 500 P.S.I. must be special ordered from the factory.
2. **STARTING:** Reduced voltage starting may be employed. This will reduce upthrust on start, starting current and mechanical stresses created by the motor's high starting torque. Reduced voltage starters, if used should accelerate the motor to full speed within two seconds. **NOTE:** Solid state reduced voltage starters are not compatible with Subtrol-Plus.
3. **DOCUMENTATION:** Form 2208, Submersible Booster Installation Record, must be completed for all Franklin submersible motor applied with inline booster pumps.

Send to:
Franklin Electric
400 E. Spring Street, Bluffton, IN 46714
Attn: Field Service Dept.

Upon receipt and analysis of the data and installation details supplied on Form No. 2207, Franklin engineers will advise by letter if the installation will be covered by Franklin's warranty.

Phase Converters

THE WARRANTY ON ALL FRANKLIN THREE PHASE SUBMERSIBLE MOTORS IS VOID IF OPERATED FROM SINGLE PHASE POWER THROUGH A PHASE CONVERTER UNLESS APPROVAL OF THE SYSTEM (IN WRITING) HAS BEEN OBTAINED FROM THE FRANKLIN ELECTRIC FIELD SERVICE DEPARTMENT.

There are a number of types of phase converters available. Each is intended to allow the use of a three phase motor on a single phase power line. Some of these designs present problems which can lead to motor failure.

Phase converters, with the exception of solid state models, create a "manufactured voltage" leg by the use of capacitors, winding taps or adjustable relays. In all of these arrangements, the voltage balance is critical to the current balance. Some phase converters may be well balanced at one point on the system operating curve. Submersible pumping systems often operate at differing points on the curve as water levels and operating pressures fluctuate. Other converters may be well balanced at varying loads, but their output may vary widely with fluctuations in the input voltage.

The following guidelines have been established for submersible installations to be warrantable when used with a phase converter.

1. Limit pump loading to rated horsepower. Do not load into motor service factor.
2. Maintain at least three feet per second motor cooling. Use a flow sleeve when necessary.
3. Use time delay fuses or circuit breakers in pump panel. Standard fuses or circuit breakers do not provide secondary motor protection.
4. Subtrol Plus may be used on electro mechanical type phase converters, however special connections are required. Consult Subtrol Plus Manual for connections of receiver and lightning arrestor.
5. Subtrol Plus will not work with electronic solid state phase converters.
6. Current unbalance must not exceed 10% under varying load conditions.
7. Report system parameters on Form 2207, Submersible Motor Installation Record.

Send to:
Franklin Electric
400 E. Spring Street, Bluffton, IN 46714
Attention: Field Service Department

Upon receipt and analysis of the data and installation details supplied on Form No. 2207, Franklin engineers will advise by letter if the installation will be covered by Franklin's warranty.

Reduced Voltage Starters

All Franklin three phase submersible motors are suitable for full voltage starting. Under this condition the motor speed goes from zero to full speed within one half second or less. The load current goes from zero to locked rotor amps, about 5 to 7 times running amps, and drops to running amps at full speed. This may dim lights, cause momentary voltage dips to other electrical equipment and shock load power distribution transformers.

Power companies often require soft starters or limit motor KVA load that may be started "directly on line". There are also times when it may be desirable to reduce motor starting torque. This lessens the stress on shafts, couplings, and castings as well as the supporting discharge piping. A "strong" voltage supply and very little cable voltage drop produces high starting torque. In other words, this is an installation that is electrically and mechanically "stiff". Reduced voltage starters are often used to reduce starting KVA or torque, and sometimes to slow the immediate acceleration of the water on start up to control upthrust and waterhammer.

With maximum recommended cable length where there is a 5% voltage drop in the cable, there will be about 20% reduced starting current and about 36% reduced starting torque compared to having rated voltage at the motor. On some installations this may be enough reduction in starting current so that reduced voltage starters may not be required.

Standard 3 Ø motors have three line leads so only resistance, autotransformers, or solid state reduced voltage starters may be used. The autotransformer type is preferred over resistance and solid state types because it draws lower line current for the same starting torque. Wye-Delta starters are used with six lead Wye-Delta motors. All Franklin 6" and 8" three phase motors are available in six lead Wye-Delta construction. Consult the factory for details and availability. Part winding starters are not usable with Franklin Electric submersible motors.

When reduced voltage starters are used it is recommended the motor be supplied with at least 55% of rated voltage to ensure adequate starting torque.

Most autotransformer starters have 65% and 85% taps. Setting the taps on these starters depends on the percentage of the maximum allowable cable length used in the system. If the cable length is less than 50% of the maximum allowable, either the 65% or 80% taps may be used. When the cable length is more than 50% of the allowable, the 80% tap should be used.

Solid state reduced voltage starters may be used with submersibles, but may not be usable with Subtrol-Plus. Consult the factory.

Both electromechanical and solid state starters have adjustable time delays for starting. Typically they are preset at 30 seconds. They must be set so the motor is at full voltage within two to three seconds maximum to prevent overload trip and unnecessary motor heating.

Open transition starters, which momentarily interrupt power during the starting cycle, are not recommended. Should the motor/pump rotating parts be passing through their critical speed, as low voltage is removed and high voltage applied, the resulting stresses can break shafts and couplings. Only closed transition starters which have no interruption of power during the starting cycle should be used.

Three Phase Power Unbalance

A full three phase supply is recommended for all three phase motors, consisting of three individual transformers or one three phase transformer. So-called "open" delta or wye connections using only two transformers can be used, but are more likely to cause problems, such as poor performance overload tripping or early motor failure due to current unbalance.

Transformer ratings should be no smaller than listed in Table 2 on page 3 for supply power to the motor alone.

Phase designation of leads for CCW rotation viewing shaft end.

To reverse rotation, interchange any two leads.

- Phase 1 or "A" – Black Motor Lead
- Phase 2 or "B" – Yellow Motor Lead
- Phase 3 or "C" – Red Motor Lead

NOTICE: Phase 1, 2 and 3 may not be L1, L2 and L3.

Checking and correcting rotation and current unbalance

1. Establish correct motor rotation by running in both directions. Change rotation by exchanging any two of the three motor leads. The rotation that gives the most water flow is always the correct rotation.

2. After correct rotation has been established, check the current in each of the three motor leads and calculate the current unbalance as explained in 3 below.

If the current unbalance is 2% or less, leave the leads as connected.

If the current unbalance is more than 2%, current readings should be checked on each leg using each of the three possible hookups. Roll the motor leads across the starter in the same direction to prevent motor reversal.

3. To calculate percent of current unbalance:
 - A. Add the three line amp values together.
 - B. Divide the sum by three, yielding average current
 - C. Pick the amp value which is furthest from the average current (either high or low).
 - D. Determine the difference between this amp value (furthest from average) and the average.
 - E. Divide the difference by the average. Multiply the result by 100 to determine percent of unbalance.

4. Current unbalance should not exceed 5% at service factor load or 10% at rated input load. If the unbalance cannot be corrected by rolling leads, the source of the unbalance must be located and corrected. If, on the three possible hookups, the leg farthest from the average stays on the same power lead, most of the unbalance is coming from the power source. However, if the reading farthest from average moves with the same motor lead, the primary source of unbalance is on the "motor side" of the starter. In this instance, consider a damaged cable, leaking splice, poor connection, or faulty motor winding.

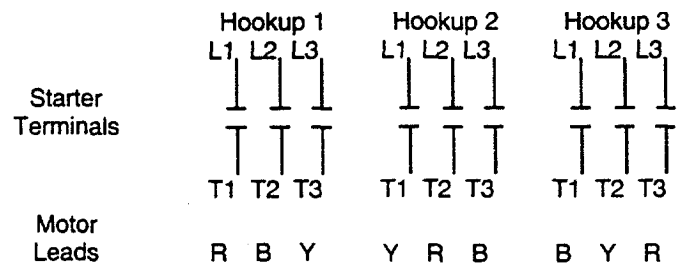

Example:

| | | |
|--------------------|--------------------|--------------------|
| R = 51 amps | Y = 50 amps | B = 50 amps |
| B = 46 amps | R = 48 amps | Y = 49 amps |
| Y = 53 amps | B = 52 amps | R = 51 amps |
| Total = 150 amps | Total = 150 amps | Total = 150 amps |
| + 3 = 50 amps | + 3 = 50 amps | + 3 = 50 amps |
| - 46 = 4 amps | - 48 = 2 amps | - 49 = 1 amp |
| 4 + 50 = .08 or 8% | 2 + 50 = .04 or 4% | 1 + 50 = .02 or 2% |

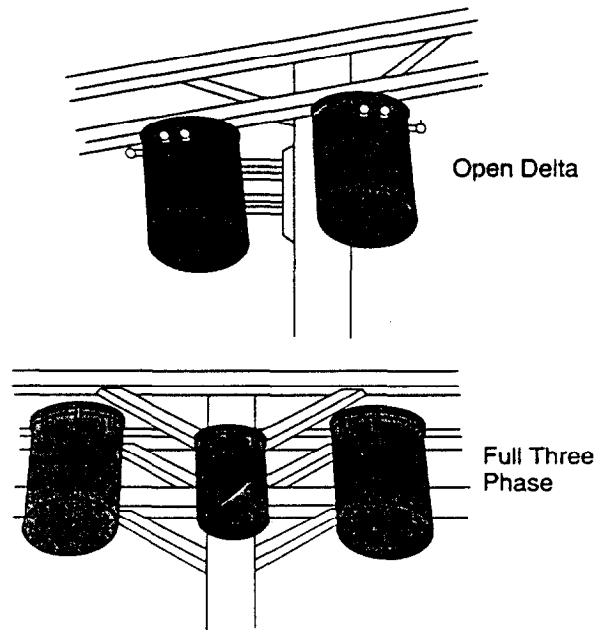

FIG 12

Three Phase Starter Diagrams

Three phase combination magnetic starters have two distinct circuits, a power circuit and a control circuit.

The power circuit consists of a circuit breaker or fused line switch, contacts, and overload heaters connecting incoming power lines, L1, L2, L3 and the three phase motor.

The control circuit consists of the magnetic coil, overload contacts and a control device such as a pressure switch. When the control device contacts are closed, current flows through the magnetic contactor coil, the contacts close, and power is applied to the motor. Hand-Off-Auto switches, start timers, level controls and other control devices may also be wired in series in the control circuit.

FIG 9 LINE VOLTAGE CONTROL

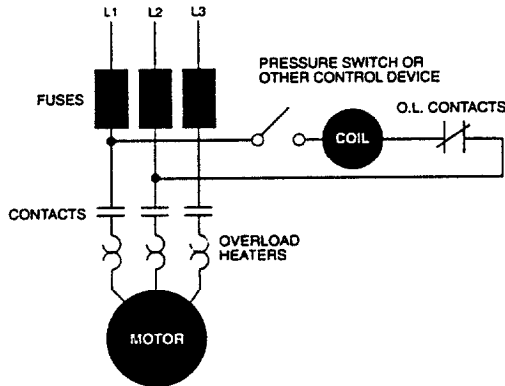

Probably the most common type of control encountered. Since the coil is connected directly across the power lines, L1 and L2, the coil voltage and frequency must match the line voltage.

FIG 10 LOW VOLTAGE TRANSFORMER CONTROL

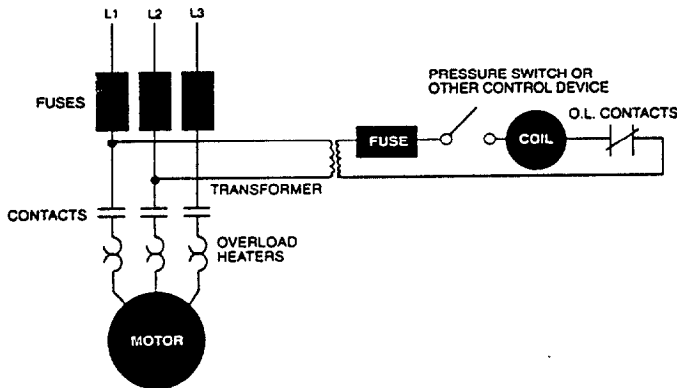

Used when it is desirable to operate push buttons or other control devices at some voltage lower than the motor voltage. The transformer primary must match the line voltage and the coil voltage must match the secondary voltage of the transformer.

FIG 11 EXTERNAL VOLTAGE CONTROL

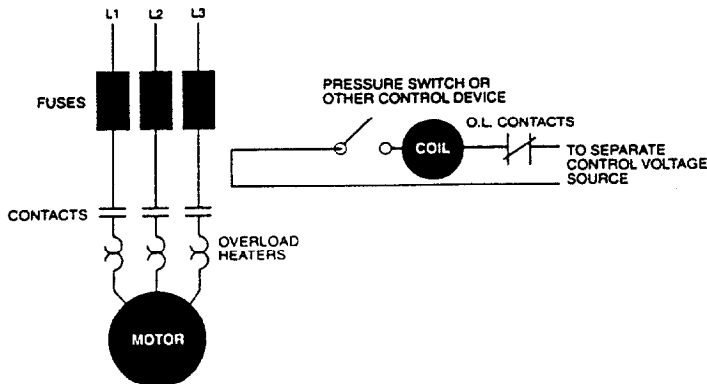

Control of a power circuit by a lower control circuit voltage can also be obtained by connecting to a separate control voltage source. The coil rating must match the control voltage source, such as 115 or 24 volts.

Overload Protection Of Three Phase Submersible Motors

Notes for Overload Protection Tables (Page 16)

Footnotes:

Note 1: Furnas intermediate sizes between NEMA starter sizes apply where (1) is shown in tables, size 1 3/4 replacing 2, 2 1/2 replacing 3, and 3 1/2 replacing 4. Heaters listed apply to Innova 45 designs and Defenite Purpose Class 16 starters through their available range, and to standard starters in larger sizes. Overload relay adjustments should be set no higher than 100%, unless necessary to stop nuisance tripping with measured amps in all lines below nameplate maximum.

Note 2: General Electric heaters are type CR123 usable only on type CR124 overload relays. Adjustment should be set no higher than 100%, unless necessary to stop nuisance tripping with measured amps in all lines below nameplate maximum.

Note 3: Adjustable overload relay amp settings apply to approved types listed below. Relay adjustment should be set at the specified SET amps, and only if tripping occurs with amps in all lines measured to be within nameplate maximum amps should the setting be increased, not to exceed the MAX value shown.

Note 4: Heaters shown for ratings requiring NEMA size 5 starters are all used with current transformers per manufacturer standards. Adjustable relays may or may not use current transformers depending on design.

Some approved types may only be available for part of the listed motor ratings. When relays are used with current transformers, relay setting is the specified amps divided by the transformer ratio.

Approved Adjustable Overload Relays

- AEG Series: B17S, B27S, B27-2
- ABB Type: RVH 40, RVH65, RVP160
- Allen Bradley: Bulletin 193
- Fanal Types: K7 or K7D through K400
- Fuji Types: TR-OQ, TR-OQH, TR-2NQ, TR-3NQ, TR-6NQ, RCa 3737-1CQ & 1CQ11
- Furnas Types: US15 48AG & 48BG ESP100-Class 10 only
- General Electric CR4G, GR7G
- Klockner-Moeller Types: Z00, Z1, Z4, PKZM1, PKZM3 & PKZ2
- Lovato RC9, RC22, & RC80
- Asco-Delta Types: DQ, LR1-D, LR1-F & LR2-D
- Sprecher and Schuh Types: CT, CT1, CTA 1, CT3K, CT3-12 thru CT3-42
- Siemens Types: 3UA50, -52, -54, -58, -59, -62, -66, -MSP, 3VE
- Square D Class 9065, Types: TD, TE, TF, TG, TJ, TK, TR, & TJE
- Telemecanique Type: LR1-D, LR1-F, & LR2-D
- Westinghouse Types: FT13, FT23, FT33, FT43, K7D, K27D, & K67D
- Westmaster: OLWROO and OLWTOO suffix D thru P

Other relay types from these and other manufacturers may or may not provide acceptable protection, and they should not be used without approval of Franklin Electric.

Notice: Warranty on three phase submersible motors is void unless Subtrol or proper quick trip ambient compensated protection is used on all three motor lines.

Power Factor Correction

In some installations, power supply limitations make it necessary or desirable to increase the power factor of a submersible motor. The table lists the capacitive KVAR required to increase the power factor of large Franklin three phase submersible motors to the approximate values shown at maximum input loading.

Capacitors must be connected on the line side of the overload relay, or overload protection will be lost.

Table 17 KVAR Required

| Motor HP | Hertz | Motor P.F. | Required KVAR (cos φ) | | |
|----------|-------|------------|-----------------------|-----|-------|
| | | | .90 | .95 | .9700 |
| 5 | 60 | .82 | 1.2 | 2.1 | 4 |
| 7.5 | 60 | .83 | 1.7 | 3.1 | 6 |
| 10 | 60 | .85 | 1.5 | 3.3 | 7 |
| 15 | 60 | .85 | 2.2 | 4.7 | 10 |
| 20 | 60 | .87 | 1.7 | 5.0 | 12 |
| 25 | 60 | .87 | 2.1 | 6.2 | 15 |
| 30 | 60 | .87 | 2.5 | 7.4 | 18 |
| 40 | 60 | .86 | 4.5 | 11 | 24 |
| 50 | 60 | .85 | 7.1 | 15 | 32 |
| 60 | 60 | .85 | 8.4 | 18 | 38 |
| 75 | 60 | .87 | 6.3 | 18 | 43 |
| 100 | 60 | .86 | 11 | 27 | 60 |
| 125 | 60 | .85 | 17 | 36 | 77 |
| 150 | 60 | .85 | 20 | 42 | 90 |
| 175 | 60 | .88 | 9.6 | 36 | 93 |
| 200 | 60 | .87 | 16 | 46 | 110 |

Overload Protection Of Three Phase Submersible Motors

The characteristics of submersible motors are different from standard motors and special overload protection is required. If the motor is stalled, the overload protector must trip within 10 seconds to protect the motor windings. The installer must use SUBTROL or the quick-trip protection shown in these tables. All recommended overload selections are of the ambient compensated type to maintain protection at high and low air temperatures.

All heaters and amp settings shown are based on total line amps. When a six-lead motor is used with a Wye-Delta starter, heaters carrying phase amps must be selected or adjusted based on motor amps divided by 1.732.

The tables below list the correct selection and settings for several manufacturers. Approval of other types may be requested by phoning the Franklin Electric Hotline at 800-348-2420.

Refer To Notes On Page 17.

Table 14 60 Hertz 4" Motors

| HP | Volts | NEMA Starter Size | Heaters For Overload Relays | | | Adjustable Relays (Note 3) | |
|-----|-------|-------------------|-----------------------------|---------------|---------------|----------------------------|------|
| | | | Furnas (Note 1) | Allen Bradley | G.E. (Note 2) | Set | Max |
| 1/2 | 200 | 00 | K31 | J16 | L380A | 3.13 | 3.4 |
| | 230 | 00 | K29 | J15 | L343A | 2.76 | 3.0 |
| | 460 | 00 | — | J8 | L174A | 1.38 | 1.5 |
| | 575 | 00 | — | J5 | — | 1.10 | 1.2 |
| 3/4 | 200 | 00 | K36 | J19 | L510A | 4.23 | 4.6 |
| | 230 | 00 | K33 | J18 | L463A | 3.68 | 4.0 |
| | 460 | 00 | K23 | J11 | L232A | 1.84 | 2.0 |
| | 575 | 00 | K21 | J8 | L193A | 1.47 | 1.6 |
| 1 | 200 | 00 | K37 | J21 | L618A | 5.06 | 5.5 |
| | 230 | 00 | K36 | J19 | L561A | 4.42 | 4.8 |
| | 460 | 00 | K26 | J12 | L282A | 2.21 | 2.4 |
| | 575 | 00 | K23 | J10 | L211A | 1.75 | 1.9 |
| 1.5 | 200 | 00 | K43 | J24 | L825A | 6.81 | 7.4 |
| | 230 | 00 | K41 | J22 | L750A | 5.89 | 6.4 |
| | 460 | 00 | K29 | J15 | L380A | 2.94 | 3.2 |
| | 575 | 00 | K27 | J13 | L310A | 2.39 | 2.6 |
| 2 | 200 | 0 | K50 | J26 | L111B | 8.46 | 9.2 |
| | 230 | 0 | K43 | J25 | L910A | 7.36 | 8.0 |
| | 460 | 00 | K33 | J18 | L463A | 3.68 | 4.0 |
| | 575 | 00 | K29 | J15 | L380A | 2.94 | 3.2 |
| 3 | 200 | 0 | K54 | J29 | L135B | 11.2 | 12.2 |
| | 230 | 0 | K52 | J28 | L122B | 9.75 | 10.6 |
| | 460 | 0 | K37 | J20 | L618A | 4.88 | 5.3 |
| | 575 | 0 | K33 | J18 | L463A | 3.86 | 4.2 |
| 5 | 200 | 1 | K61 | J34 | L220B | 18.4 | 20.0 |
| | 230 | 1 | K61 | J32 | L199B | 16.0 | 17.4 |
| | 460 | 0 | K49 | J25 | L100B | 8.00 | 8.7 |
| | 575 | 0 | K42 | J23 | L825A | 6.44 | 7.0 |
| 7.5 | 200 | 1 | K68 | J38 | L322B | 27.0 | 29.3 |
| | 230 | 1 | K67 | J36 | L293B | 23.5 | 25.5 |
| | 460 | 1 | K55 | J29 | L147B | 11.8 | 12.8 |
| | 575 | 1 | K52 | J27 | L122B | 9.38 | 10.2 |
| 10 | 460 | 1 | K61 | J33 | L220B | 17.5 | 18.8 |
| | 575 | 1 | K57 | J31 | L181B | 14.0 | 15.0 |

Table 15 60 Hertz 6" Motors

| HP | Volts | NEMA Starter Size | Heaters For Overload Relays | | | Adjustable Relays (Note 3) | |
|-----|-------|-------------------|-----------------------------|---------------|---------------|----------------------------|-------|
| | | | Furnas (Note 1) | Allen Bradley | G.E. (Note 2) | Set | Max |
| 5 | 200 | 1 | K61 | J34 | L220B | 18.4 | 20.0 |
| | 230 | 1 | K61 | J32 | L199B | 16.0 | 17.4 |
| | 460 | 0 | K49 | J25 | L100B | 8.0 | 8.7 |
| | 575 | 0 | K42 | J23 | L825A | 6.44 | 7.0 |
| 7.5 | 200 | 1 | K68 | J38 | L322B | 27.0 | 29.3 |
| | 230 | 1 | K67 | J36 | L293B | 23.5 | 25.5 |
| | 460 | 1 | K55 | J29 | L147B | 11.8 | 12.8 |
| | 575 | 1 | K52 | J27 | L122B | 9.38 | 10.2 |
| 10 | 200 | 2(1) | K72 | J40 | L426B | 34.0 | 37.0 |
| | 230 | 2(1) | K70 | J38 | L390B | 29.6 | 32.2 |
| | 460 | 1 | K58 | J32 | L181B | 14.8 | 16.1 |
| | 575 | 1 | K55 | J30 | L147B | 11.9 | 12.9 |
| 15 | 200 | 3(1) | K76 | J43 | L622B | 50.1 | 54.5 |
| | 230 | 2 | K75 | J42 | L520B | 43.6 | 47.4 |
| | 460 | 2(1) | K64 | J35 | L265B | 21.8 | 23.7 |
| | 575 | 2(1) | K61 | J33 | L220B | 17.5 | 19.0 |
| 20 | 200 | 3 | K78 | J45 | L787B | 64.1 | 69.7 |
| | 230 | 3(1) | K77 | J44 | L710B | 55.8 | 60.6 |
| | 460 | 2 | K69 | J38 | L352B | 27.9 | 30.3 |
| | 575 | 2 | K64 | J35 | L293B | 22.3 | 24.2 |
| 25 | 200 | 3 | K86 | J71 | L950B | 79.4 | 86.3 |
| | 230 | 3 | K83 | J46 | L866B | 69.0 | 75.0 |
| | 460 | 2 | K72 | J40 | L426B | 34.5 | 37.5 |
| | 575 | 2 | K69 | J37 | L352B | 27.6 | 30.0 |
| 30 | 200 | 4(1) | K88 | J72 | L107C | 95.7 | 104.0 |
| | 230 | 3 | K87 | J71 | L107C | 83.2 | 90.4 |
| | 460 | 3(1) | K74 | J41 | L520B | 41.6 | 45.2 |
| | 575 | 3(1) | K72 | J39 | L390B | 33.3 | 36.2 |
| 40 | 460 | 3 | K77 | J44 | L710B | 57.0 | 62.0 |
| | 575 | 3 | K74 | J42 | L593B | 45.6 | 49.6 |
| 50 | 460 | 3 | K83 | J46 | L866B | 70.8 | 77.0 |
| | 575 | 3 | K77 | J44 | L701B | 56.7 | 61.6 |
| 60 | 460 | 4(1) | K87 | J71 | L107C | 83.7 | 91.0 |
| | 575 | 4(1) | K78 | J45 | L787B | 67.0 | 72.8 |

Table 16 60 Hertz 8" Motors

| HP | Volts | NEMA Starter Size | Heaters For Overload Relays | | | Adjustable Relays (Note 3) | |
|-----|--------|-------------------|-----------------------------|---------------|---------------|----------------------------|------|
| | | | Furnas (Note 1) | Allen Bradley | G.E. (Note 2) | Set | Max |
| 40 | 460(4) | 3 | K77 | J44 | L710B | 57.0 | 62 |
| | 575 | 3 | K74 | J42 | L593B | 45.6 | 49.6 |
| 50 | 460(4) | 3 | K83 | J46 | L866B | 70.8 | 77 |
| | 575 | 3 | K77 | J44 | L710B | 56.7 | 61.6 |
| 60 | 460(4) | 4(1) | K87 | J71 | L107C | 83.7 | 91 |
| | 575 | 4(1) | K78 | J45 | L787B | 67.0 | 72.8 |
| 75 | 460(4) | 4(1) | K89 | J73 | L126C | 101 | 110 |
| | 575 | 4(1) | K86 | J70 | L950B | 81.0 | 88 |
| 100 | 460(4) | 4 | K94 | J76 | L155C | 136 | 148 |
| | 575 | 4 | K87 | J73 | L142C | 108 | 118 |
| 125 | 460(4) | 5 | K29 | J15 | L111B | 173 | 189 |
| | 575 | 5 | K26 | J13 | L910A | 139 | 151 |
| 150 | 460(4) | 5 | K32 | J17 | L122B | 203 | 221 |
| | 575 | 5 | K28 | J14 | L100B | 163 | 177 |
| 175 | 460(4) | 5 | K33 | J18 | L147B | 230 | 250 |
| | 575 | 5 | K31 | J16 | L111B | 184 | 200 |
| 200 | 460(4) | 5 | K34 | J20 | L165B | 263 | 286 |
| | 575 | 5 | K32 | J17 | L135B | 211 | 229 |

Notice: Warranty on three phase submersible motors is void unless Subtrol or proper quick trip ambient compensated protection is used in all three motor lines.

Application Three Phase Motors

Table 12 Three Phase Motor Specifications (60 Hertz)

| Motor Model Prefix | Rated Input | | | | Maximum S.F. Load | | Line to Line Res. | Efficiency % | | | Power Factor % | | | Locked Rotor Ampe | KVA | Circuit Breaker or Fuse AMPS | |
|--------------------|-------------|-------|-----|------|-------------------|-------|-------------------|--------------|----|----|----------------|----|----|-------------------|-----|------------------------------|-------|
| | HP | Volts | FLA | S.F. | Ampe | Watts | | FLA | FL | LA | S.F. | FL | LA | | | Std. | Delay |

4 Inch

| | | | | | | | | | | | | | | | | | | | |
|---------|-------|-----|----|------|------|-------|------|-------|-----------|------|------|------|------|------|------|------|---|----|----|
| 2345014 | 1/2 | 200 | 60 | 1.6 | 2.8 | 635 | 3.7 | 900 | 6.64-7.3 | 66.4 | 59.4 | 53.3 | 76.6 | 64.1 | 56.5 | 17.3 | N | 10 | 5 |
| 2345114 | 1/2 | 230 | 60 | 1.6 | 2.3 | 635 | 2.9 | 900 | 9.5-10.4 | 66.4 | 59.4 | 53.3 | 76.6 | 64.1 | 56.5 | 15.0 | N | 8 | 4 |
| 2345213 | 1/2 | 460 | 60 | 1.6 | 1.2 | 635 | 1.6 | 900 | 38.4-41.6 | 66.4 | 59.4 | 53.3 | 76.6 | 64.1 | 56.5 | 7.5 | N | 4 | 2 |
| 2345024 | 3/4 | 200 | 60 | 1.5 | 3.7 | 920 | 4.7 | 1250 | 4.66-5.12 | 67.5 | 63.0 | 57.7 | 79.5 | 69.0 | 66.0 | 24.6 | N | 12 | 6 |
| 2345124 | 3/4 | 230 | 60 | 1.5 | 3.3 | 920 | 4.1 | 1250 | 7.24-7.84 | 67.5 | 63.0 | 57.7 | 79.5 | 69.0 | 66.0 | 21.4 | N | 11 | 5 |
| 2345223 | 3/4 | 460 | 60 | 1.5 | 1.6 | 920 | 2.0 | 1250 | 27.8-30.2 | 67.5 | 63.0 | 57.7 | 79.5 | 69.0 | 66.0 | 10.7 | N | 5 | 3 |
| 2345031 | 1 | 200 | 60 | 1.4 | 4.5 | 1140 | 5.7 | 1520 | 4.1-4.5 | 69.3 | 67.0 | 63.0 | 79.1 | 71.0 | 63.4 | 31.0 | M | 14 | 6 |
| 2345131 | 1 | 230 | 60 | 1.4 | 3.9 | 1140 | 4.8 | 1520 | 5.2-5.6 | 69.3 | 67.0 | 63.0 | 79.1 | 71.0 | 63.4 | 27.0 | M | 12 | 6 |
| 2345231 | 1 | 460 | 60 | 1.4 | 2.0 | 1140 | 2.4 | 1520 | 21.2-23.0 | 69.3 | 67.0 | 63.0 | 79.1 | 71.0 | 63.4 | 13.5 | M | 6 | 3 |
| 2345041 | 1 1/2 | 200 | 60 | 1.3 | 6.1 | 1570 | 7.3 | 2000 | 2.4-3.4 | 75.0 | 74.0 | 70.9 | 80.0 | 73.0 | 64.5 | 39 | K | 20 | 9 |
| 2345141 | 1 1/2 | 230 | 60 | 1.3 | 5.2 | 1570 | 6.3 | 2000 | 3.2-4.1 | 75.0 | 74.0 | 70.9 | 80.0 | 73.0 | 64.5 | 34 | K | 20 | 8 |
| 2345241 | 1 1/2 | 460 | 60 | 1.3 | 2.6 | 1570 | 3.1 | 2000 | 11.3-15.0 | 75.0 | 74.0 | 70.9 | 80.0 | 73.0 | 64.5 | 17 | K | 15 | 4 |
| 2345341 | 1 1/2 | 575 | 60 | 1.3 | 2.1 | 1570 | 2.5 | 2000 | 17.6-23.4 | 75.0 | 74.0 | 70.9 | 80.0 | 73.0 | 64.5 | 14 | K | 15 | 3 |
| 2343047 | 1 1/2 | 200 | 60 | 1.3 | 6.1 | 1570 | 7.4 | 2050 | 2.4-3.4 | 75.0 | 74.0 | 70.9 | 80.0 | 73.0 | 64.5 | 39 | K | 20 | 9 |
| 2343147 | 1 1/2 | 230 | 60 | 1.3 | 5.3 | 1570 | 6.4 | 2050 | 3.2-4.1 | 75.0 | 74.0 | 70.9 | 80.0 | 73.0 | 64.5 | 34 | K | 20 | 8 |
| 2343247 | 1 1/2 | 460 | 60 | 1.3 | 2.7 | 1570 | 3.2 | 2050 | 11.3-15.0 | 75.0 | 74.0 | 70.9 | 80.0 | 73.0 | 64.5 | 17 | K | 15 | 4 |
| 2343347 | 1 1/2 | 575 | 60 | 1.3 | 2.2 | 1570 | 2.6 | 2050 | 17.6-23.4 | 75.0 | 74.0 | 70.9 | 80.0 | 73.0 | 64.5 | 14 | K | 15 | 3 |
| 2343051 | 2 | 200 | 60 | 1.25 | 7.7 | 2050 | 9.3 | 2580 | 1.9-2.4 | 69.5 | 69.5 | 67.4 | 84.4 | 79.0 | 71.2 | 53 | L | 25 | 10 |
| 2343151 | 2 | 230 | 60 | 1.25 | 6.7 | 2050 | 8.1 | 2580 | 2.4-3.0 | 69.5 | 69.5 | 67.4 | 84.4 | 79.0 | 71.2 | 46 | L | 20 | 10 |
| 2343251 | 2 | 460 | 60 | 1.25 | 3.4 | 2050 | 4.1 | 2580 | 9.7-12.0 | 69.5 | 69.5 | 67.4 | 84.4 | 79.0 | 71.2 | 23 | L | 15 | 5 |
| 2343057 | 2 | 200 | 60 | 1.25 | 7.7 | 2150 | 9.3 | 2690 | 1.9-2.4 | 69.5 | 69.5 | 67.4 | 84.4 | 79.0 | 71.2 | 53 | L | 25 | 10 |
| 2343157 | 2 | 230 | 60 | 1.25 | 6.7 | 2150 | 8.1 | 2690 | 2.4-3.0 | 69.5 | 69.5 | 67.4 | 84.4 | 79.0 | 71.2 | 46 | L | 20 | 10 |
| 2343257 | 2 | 460 | 60 | 1.25 | 3.4 | 2150 | 4.1 | 2690 | 9.7-12.0 | 69.5 | 69.5 | 67.4 | 84.4 | 79.0 | 71.2 | 23 | L | 15 | 5 |
| 2343357 | 2 | 575 | 60 | 1.25 | 2.7 | 2150 | 3.2 | 2690 | 15.1-18.7 | 69.5 | 69.5 | 67.4 | 84.4 | 79.0 | 71.2 | 18 | L | 15 | 4 |
| 2343067 | 3 | 200 | 60 | 1.15 | 10.9 | 2980 | 12.5 | 3420 | 1.3-1.7 | 75.5 | 75.2 | 73.2 | 81.5 | 77.8 | 69.5 | 70 | K | 35 | 14 |
| 2343167 | 3 | 230 | 60 | 1.15 | 9.5 | 2980 | 10.9 | 3420 | 1.8-2.2 | 75.5 | 75.2 | 73.2 | 81.5 | 77.8 | 69.5 | 61 | K | 30 | 15 |
| 2343267 | 3 | 460 | 60 | 1.15 | 4.8 | 2980 | 5.5 | 3420 | 7.0-8.7 | 75.5 | 75.2 | 73.2 | 81.5 | 77.8 | 69.5 | 31 | K | 15 | 7 |
| 2343367 | 3 | 575 | 60 | 1.15 | 3.8 | 2980 | 4.4 | 3420 | 10.9-13.6 | 75.5 | 75.2 | 73.2 | 81.5 | 77.8 | 69.5 | 24 | K | 15 | 6 |
| 2343077 | 5 | 200 | 60 | 1.15 | 18.3 | 5050 | 20.5 | 5810 | .70-.94 | 74.0 | 74.0 | 72.2 | 84.0 | 81.0 | 73.0 | 120 | K | 50 | 24 |
| 2343177 | 5 | 230 | 60 | 1.15 | 15.9 | 5050 | 17.8 | 5810 | .93-1.2 | 74.0 | 74.0 | 72.2 | 84.0 | 81.0 | 73.0 | 104 | K | 45 | 20 |
| 2343277 | 5 | 460 | 60 | 1.15 | 8.0 | 5050 | 8.9 | 5810 | 3.6-4.4 | 74.0 | 74.0 | 72.2 | 84.0 | 81.0 | 73.0 | 52 | K | 25 | 10 |
| 2343377 | 5 | 575 | 60 | 1.15 | 6.4 | 5050 | 7.1 | 5810 | 5.6-6.9 | 74.0 | 74.0 | 72.2 | 84.0 | 81.0 | 73.0 | 42 | K | 20 | 8 |
| 2343087 | 7 1/2 | 200 | 60 | 1.15 | 26.5 | 7360 | 30.5 | 8450 | .46-.57 | 76.2 | 76.0 | 74.0 | 83.2 | 80.0 | 72.2 | 188 | K | 80 | 35 |
| 2343187 | 7 1/2 | 230 | 60 | 1.15 | 23.0 | 7360 | 26.4 | 8450 | .61-.75 | 76.2 | 76.0 | 74.0 | 83.2 | 80.0 | 72.2 | 164 | K | 70 | 30 |
| 2343287 | 7 1/2 | 460 | 60 | 1.15 | 11.5 | 7360 | 13.2 | 8450 | 2.4-3.4 | 76.2 | 76.0 | 74.0 | 83.2 | 80.0 | 72.2 | 82 | K | 35 | 15 |
| 2343387 | 7 1/2 | 575 | 60 | 1.15 | 9.2 | 7360 | 10.6 | 8450 | 3.5-5.1 | 76.2 | 76.0 | 74.0 | 83.2 | 80.0 | 72.2 | 65 | K | 30 | 12 |
| 2343297 | 10 | 460 | 60 | 1.15 | 17.0 | 10100 | 18.8 | 11700 | 1.8-2.3 | 75.2 | 74.5 | 72.0 | 79.2 | 75.5 | 67.1 | 116 | K | 50 | 20 |
| 2343397 | 10 | 575 | 60 | 1.15 | 13.6 | 10100 | 15.0 | 11700 | 2.8-3.5 | 75.2 | 74.5 | 72.0 | 79.2 | 75.5 | 67.1 | 93 | K | 40 | 20 |

6 Inch

| | | | | | | | | | | | | | | | | | | | |
|---------|-------|-----|----|------|------|------|------|------|-----------|------|------|------|------|------|------|-------|---|----|----|
| 2366506 | 5 | 200 | 60 | 1.15 | 17.5 | 4700 | 19.1 | 5400 | .68-.84 | 79.5 | 79.1 | 77.2 | 82.0 | 79.5 | 73.8 | 98.9 | H | 50 | 24 |
| 2366006 | 5 | 230 | 60 | 1.15 | 15.0 | 4700 | 16.6 | 5400 | .88-1.09 | 79.5 | 79.1 | 77.2 | 82.0 | 79.5 | 73.8 | 86 | H | 45 | 20 |
| 2366106 | 5 | 460 | 60 | 1.15 | 7.5 | 4700 | 8.3 | 5400 | 3.53-4.37 | 79.5 | 79.1 | 77.2 | 82.0 | 79.5 | 73.8 | 43 | H | 25 | 10 |
| 2366206 | 5 | 575 | 60 | 1.15 | 6.0 | 4700 | 6.4 | 5400 | 5.93-7.16 | 79.5 | 79.1 | 77.2 | 82.0 | 79.5 | 73.8 | 34.4 | H | 20 | 8 |
| 2366516 | 7 1/2 | 200 | 60 | 1.15 | 25.1 | 7000 | 28.3 | 8000 | .39-.48 | 79.8 | 80.0 | 78.7 | 83.0 | 80.5 | 73.8 | 149.5 | H | 70 | 30 |
| 2366016 | 7 1/2 | 230 | 60 | 1.15 | 21.8 | 7000 | 24.6 | 8000 | .57-.71 | 79.8 | 80.0 | 78.7 | 83.0 | 80.5 | 73.8 | 130 | H | 70 | 30 |
| 2366116 | 7 1/2 | 460 | 60 | 1.15 | 10.9 | 7000 | 12.3 | 8000 | 2.17-2.68 | 79.8 | 80.0 | 78.7 | 83.0 | 80.5 | 73.8 | 65.0 | H | 30 | 15 |
| 2366216 | 7 1/2 | 575 | 60 | 1.15 | 8.7 | 7000 | 9.8 | 8000 | 3.65-4.41 | 79.8 | 80.0 | 78.7 | 83.0 | 80.5 | 73.8 | 52 | H | 25 | 12 |

TOLL FREE HELP FROM A FRIEND

Phone Franklin Electric's toll free SERVICE HOTLINE, for answers to your installation questions on submersible pump motors. When you call, a Franklin Electric expert will offer assistance in troubleshooting submersible systems and provide immediate answers to your motor application questions.

Franklin Electric SERVICE HOTLINE 800/348-2420



Franklin Electric

Bluffton, Indiana 46714

iron flanges (class 125)

iron flanges

Class 125 (standard)

| | | | |
|-----------------------|---------------------------|----------------|-----|
| pressure ratings, psi | saturated steam: | 1 to 12 inch: | 125 |
| | | 14 to 24 inch: | 100 |
| | liquid & gas at 150°F: | 1 to 12 inch: | 175 |
| | | 14 to 24 inch: | 150 |

Class 125 (standard) iron flanges are manufactured to American National Standards, ANSI B16.1. Malleable iron material, ASTM A197;

dimensions also to Federal specifications WW-F-406.

companion flange

cast iron: fig. 1011
malleable: fig. 1035

showing hub



showing plain face

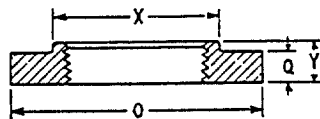

□ CI only.

| pipe size, in. | diam. of flange O, in. | thick. of flange (min.), Q, in. | diam. of hub (min.), X, in. | length through hub * (min.), Y, in. | weight (approx) each, lb. | |
|----------------|------------------------|---------------------------------|-----------------------------|-------------------------------------|---------------------------|-----------|
| | | | | | cast iron * | malleable |
| □ ¾ | 3 ¾ | ¾ | 1 ¾ | ¾ | 1.50 | |
| 1 | 4 ¼ | ¾ | 1 ½ | ¾ | 1.75 | |
| 1 ¼ | 4 ¾ | ½ | 2 ¾ | ¾ | 2.00 | |
| 1 ½ | 5 | ¾ | 2 ¾ | ¾ | 2.25 | 2.25 |
| 2 | 6 | ¾ | 3 ¾ | 1 | 4.00 | 4.00 |
| 2 ½ | 7 | 1 ¼ | 3 ¾ | 1 ½ | 6.00 | 6.00 |
| 3 | 7 ½ | ¾ | 4 ¼ | 1 ¾ | 7.63 | 7.63 |
| 3 ½ | 8 ½ | 1 ¼ | 4 1 ¾ | 1 ¼ | 9.00 | 9.00 |
| 4 | 9 | 1 ¼ | 5 ¾ | 1 ¾ | 11.75 | 11.75 |
| 5 | 10 | 1 ¼ | 6 ¾ | 1 ¾ | 14.00 | 14.00 |
| 6 | 11 | 1 | 7 ¾ | 1 ¾ | 16.50 | 16.50 |
| 8 | 13 ½ | 1 ½ | 9 1 ¼ | 1 ¾ | 26.00 | 26.00 |
| 10 | 16 | 1 ¾ | 11 1 ¾ | 1 ¾ | 37.75 | |
| 12 | 19 | 1 ¼ | 14 ¾ | 2 ¾ | 50.50 | |
| 14 O.D. | 21 | 1 ¾ | 15 ¾ | 2 ¼ | 80.00 | |
| 16 O.D. | 23 ½ | 1 ¾ | 17 ½ | 2 ½ | 100.00 | |
| 18 O.D. | 25 | 1 ¾ | 19 ¾ | 2 1 ¾ | 106.00 | |
| 20 O.D. | 27 ½ | 1 1 ¾ | 21 ¾ | 2 ¾ | 128.00 | |
| 24 O.D. | 32 | 1 ¾ | 26 | 3 ¼ | 202.00 | |

When ordering companion flanges always give outside diameter as well as nominal pipe size.

blind flange

cast iron: fig. 1018
malleable: fig. 1038

10 x 16 inches and smaller

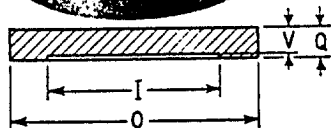

12 x 19 inches and larger

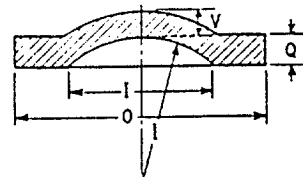

| pipe size, I, in. | diam. of flange O, in. | thick. of flange (min.), Q, in. | wall thick. V, in. | weight (approx) each, lb. | |
|-------------------|------------------------|---------------------------------|--------------------|---------------------------|-----------|
| | | | | cast iron * | malleable |
| 1 | 4 ¼ | ¾ | ¾ | 2.00 | |
| 1 ¼ | 4 ¾ | ½ | ¾ | 2.25 | |
| 1 ½ | 5 | ¾ | ½ | 3.75 | |
| 2 | 6 | ¾ | ¾ | 4.00 | 4.00 |
| 2 ½ | 7 | 1 ¼ | ¾ | 6.75 | 6.75 |
| 3 | 7 ½ | ¾ | 1 ¼ | 8.00 | 8.00 |
| 3 ½ | 8 ½ | 1 ¼ | ¾ | 11.00 | 11.00 |
| 4 | 9 | 1 ¼ | ¾ | 14.00 | 14.00 |
| 5 | 10 | 1 ¼ | ¾ | 18.00 | 18.00 |
| 6 | 11 | 1 | 1 ¼ | 23.00 | 23.00 |
| 8 | 13 ½ | 1 ½ | 1 ¼ | 40.00 | 40.00 |
| 10 | 16 | 1 ¾ | 1 ½ | 59.00 | |
| 12 | 19 | 1 ¼ | 1 ¾ | 88.00 | |
| 14 O.D. | 21 | 1 ¾ | ¾ | 115.00 | |
| 16 O.D. | 23 ½ | 1 ¾ | 1 | 160.00 | |
| 18 O.D. | 25 | 1 ¾ | 1 ¼ | 190.00 | |
| 20 O.D. | 27 ½ | 1 1 ¾ | 1 ½ | 250.00 | |
| 24 O.D. | 32 | 1 ¾ | 1 ¼ | 370.00 | |

All Standard blind flanges, sizes 12 inch (19 inch O.D.) and larger must be dished, with inside radius equal to the port diameter.

When ordering blind flanges always give outside diameter.

* All Class 125 cast iron standard flanges have a flat face.

ROTATION RESISTANT WIRE ROPES

Blue Strand Rotation Resistant Ropes are available in a full range of sizes, grades and constructions:

- Standard constructions for single part and multipart lifting.
- Special wire rope constructions for increased service life in particularly demanding applications—DYFORM -18 HSLR, Dyform 34LR and 35LS.

NOTE:

1. Swivels are not recommended for use with rotation resistant ropes.
2. Although B30 standards permit rotation resistant ropes to be used under certain conditions at design factors of 3.5:1, we recommend a minimum design factor of 5:1 and a design factor of 7:1 for extended rope life.

Characteristics

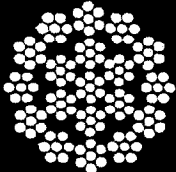
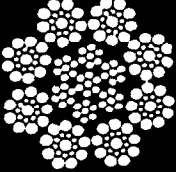
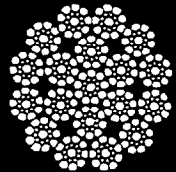
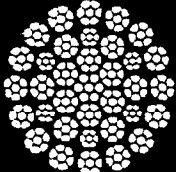
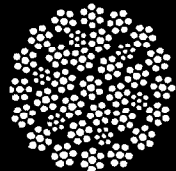
| | | |
|---|---|---|
|  | <p>19 x 7 Rotation Resistant Rope</p> | <p>Inner strands are left lang lay; outer strands are right regular lay; the natural rotation tendency of one layer is balanced by the other. Not recommended for multiple part lifting.</p> |
|  | <p>8 x 19 Rotation Resistant Rope</p> | <p>Inner and outer strands are laid in opposing directions to counter rotation. More easily damaged in service than other ropes. Can be used for multiple part lifting.</p> |
|  | <p>Dyform® -18 HSLR Rotation Resistant Ropes</p> | <p>Compacted strands with outside and inside strands laid in opposite directions for superior rotation resistance. Can be used for multiple part lifting. Dyform-18 HSLR, made with higher strength steel wires, offers 35% greater strength.</p> |
|  | <p>Dyform® -34LR</p> | <p>Strongest, most rotation resistant of all rotation resistant wire ropes; used for the most demanding hoisting applications.</p> |
|  | <p>35LS</p> | <p>Same rotation resistance as Dyform-34LR; used for demanding applications where highest strength is not mandatory.</p> |

Order Guide:

19 x 7 is a bright, IWRC, right regular wire rope. It may be ordered in diameters from 3/16" to 1 5/8" ...EIP or IPS grade.

8 x 19 is a bright, IWRC, right regular lay wire rope. It may be ordered in diameters from 7/16" to 1 1/2" ...EIP or IPS.

Dyform-18 HSLR is a bright, special grade, strand core, right regular lay wire rope. It may be ordered in diameters from 3/8" to 1 1/4".

Dyform 34LR and 34LS are specially constructed wire ropes. Inquire for details.

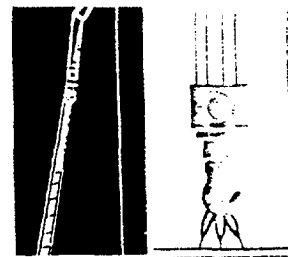

19 x 7 Rotation Resistant Rope

| Diam., in. | Nominal Strength,* Tons | | Approx. Wt./Ft., lb. |
|---------------|----------------------------|------|----------------------------|
| | EIP | IPS | |
| 3/16 | 1.57 | 1.42 | 0.064 |
| 1/4 | 2.77 | 2.51 | 0.113 |
| 5/16 | 4.30 | 3.90 | 0.177 |
| 3/8 | 6.15 | 5.59 | 0.25 |
| 7/16 | 8.33 | 7.58 | 0.35 |
| 1/2 | 10.8 | 9.85 | 0.45 |
| 9/16 | 13.6 | 12.4 | 0.58 |
| 5/8 | 16.8 | 15.3 | 0.71 |
| 3/4 | 24.0 | 21.8 | 1.02 |
| 7/8 | 32.5 | 29.5 | 1.39 |
| 1 | 42.2 | 38.3 | 1.82 |
| 1 1/8 | 53.1 | 48.2 | 2.30 |
| 1 1/4 | 65.1 | 59.2 | 2.80 |
| 1 3/8 | 78.4 | 71.3 | 3.43 |
| 1 1/2 | 92.8 | 84.4 | 4.08 |
| 1 5/8 | 108.0 | 98.4 | 4.80 |

8 x 19 Rotation Resistant Rope

| Diam., in. | Nominal Strength,* Tons | | Approx. Wt./Ft., lb. |
|---------------|----------------------------|------|----------------------------|
| | EIP | IPS | |
| 7/16 | 8.97 | 7.80 | 0.36 |
| 1/2 | 11.7 | 10.2 | 0.47 |
| 9/16 | 14.7 | 12.8 | 0.60 |
| 5/8 | 18.1 | 15.7 | 0.73 |
| 3/4 | 25.9 | 22.6 | 1.06 |
| 7/8 | 35.0 | 30.5 | 1.44 |
| 1 | 45.5 | 39.6 | 1.88 |
| 1 1/8 | 57.3 | 49.8 | 2.39 |
| 1 1/4 | 70.5 | 61.3 | 2.94 |
| 1 3/8 | 84.9 | 73.8 | 3.56 |
| 1 1/2 | 100.0 | 87.3 | 4.24 |

* Acceptance strength is not less than 2 1/2% below the nominal breaking strengths listed.

Note: These strengths apply only when a test is conducted with both ends fixed. When in use, the strength of these ropes may be reduced if one end is free to rotate.

Dyform®-18 HSLR Rotation Resistant Rope

| Diameter in. † | Nominal Strength*, Tons | Approx. Wt./Ft., lb. |
|-------------------|-------------------------------|----------------------------|
| 3/8 | 8.3 | .27 |
| 7/16 | 11.2 | .37 |
| 1/2 | 14.6 | .51 |
| 9/16 | 18.5 | .64 |
| 5/8 | 22.7 | .79 |
| 3/4 | 32.4 | 1.1 |
| 7/8 | 43.8 | 1.5 |
| 1 | 57.5 | 2.0 |
| 1 1/8 | 71.5 | 2.5 |
| 1 1/4 | 87.9 | 3.1 |

Other sizes available on request

Dyform®-34LR and 35LS Rotation Resistant Rope

| Diameter | | Nominal Strength* Tons (2000 lbs.) | | Approx. Wt./Ft., lb. | |
|----------|-------|---------------------------------------|--------|-------------------------|------|
| mm | in. | Dyform 34LR | 35LS | Dyform 34LR | 35LS |
| 13 | 1/2 | 15.65 | 14.30 | .54 | .50 |
| 14 | 9/16 | 18.85 | 16.60 | .64 | .58 |
| 16 | 5/8 | 24.80 | 21.65 | .84 | .77 |
| 17 | | 27.23 | 24.60 | .92 | .88 |
| 17.5 | | 28.77 | 26.46 | 1.01 | .91 |
| 18 | | 31.09 | 28.20 | 1.05 | .97 |
| 19 | 3/4 | 34.06 | 31.30 | 1.15 | 1.09 |
| 20 | | 38.14 | 34.15 | 1.28 | 1.19 |
| 22 | 7/8 | 46.63 | 41.55 | 1.57 | 1.44 |
| 24 | | 54.35 | 48.90 | 1.81 | 1.73 |
| 26 | 1 | 64.16 | 58.40 | 2.16 | 2.05 |
| 28 | 1 1/8 | 75.08 | 66.0 | 2.53 | 2.37 |
| 30 | | 83.79 | 77.45 | 2.80 | 2.69 |
| 32 | 1 1/4 | 99.22 | 86.85 | 3.36 | 3.08 |
| 34 | 1 3/8 | 109.14 | 98.30 | 3.68 | 3.47 |
| 38 | 1 1/2 | 138.91 | 122.35 | 4.68 | 4.34 |

* Rope strengths based on conversion from metric rope strength using 200 kg/mm² nominal wire grade.